

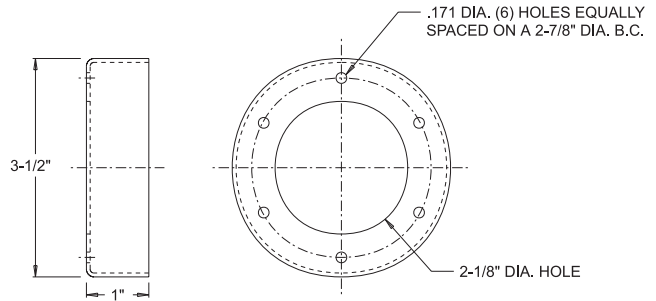

# RISERS

## Filler Breather Riser



- VESCOR® Filler Breather Weld Riser is designed to raise filler breathers 1" above the mounting surface of the reservoir
- Eliminate the need to drill and tap tank top. Just weld in place
- Prevent contamination from entering reservoir
- Round design
- Use with VESCOR® bayonet filler breathers

Vescor Part Number	Style	Description
5275	Round	Filler Breather Weld Riser

## Suction Flange Riser

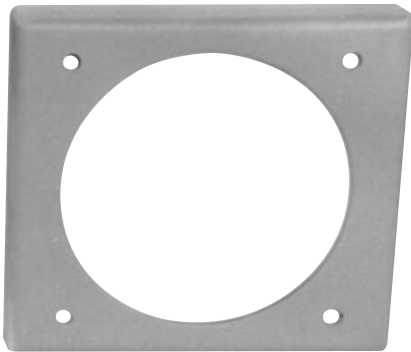

- VESCOR® Suction Flange Risers are designed to raise suction flanges 1" above the mounting surface of the reservoir
- Prevents contamination from entering the reservoir
- Use with VESCOR® Suction Flanges

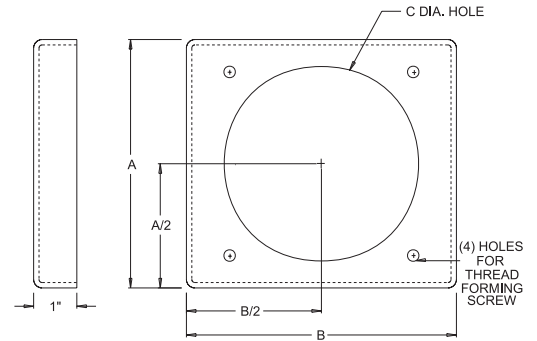

Vescor Part Number	A Dimension	B Dimension	C Diameter	Use with Pipe/Tube
5150	5 <sup>3</sup> / <sub>4</sub> "	6 <sup>1</sup> / <sub>4</sub> "	4 <sup>1</sup> / <sub>2</sub> "	1/2" to 2"
5151	7 <sup>3</sup> / <sub>4</sub> "	8 <sup>1</sup> / <sub>4</sub> "	6 <sup>1</sup> / <sub>2</sub> "	1 1/2" to 4"

## Return Flange Riser



- VESCOR® Return Flange Risers are designed to raise return flanges 1" above the mounting surface of the reservoir
- Prevents contamination from entering reservoir
- Use with VESCOR® Return Flanges

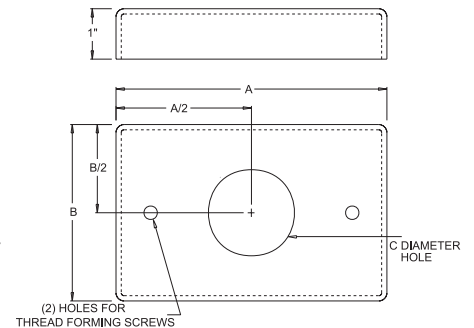

Vescor Part Number	A Dimension	B Dimension	C Diameter	Use with Pipe	Use with Tube
5156	5 <sup>3</sup> / <sub>8</sub> "	3 1/2"	1 <sup>13</sup> / <sub>16</sub> "	1/2" to 1 1/2"	3/8" to 1 1/2"
5157	5 <sup>3</sup> / <sub>8</sub> "	4"	2 <sup>9</sup> / <sub>16</sub> "	2"	2"

NOTE: WITH VESCORS' POLICY OF CONSTANTLY IMPROVING ITS PRODUCTS, SPECIFICATIONS ARE SUBJECT TO CHANGE WITHOUT NOTICE.