

Model CP16



Description Clutch Pumps
 Flow Range To 38 GPM (143.8 LTR)
 Displacements To 3.904 C.I.R. (63.74 CC's/REV.)
 Maximum Pressure to. 3000 PSI (207 BAR)
 Maximum Speed to. 3600 RPM
 Rotation A or C
 Bearings Journal
 Construction Cast Iron Gear Plates with Aluminum Flange and Cover Plate

Performance Data

PUMP MODEL	SECTION SIZE	DISPLACEMENT/REVOLUTION (Theoretical)					MAXIMUM PRESSURE						MAXIMUM SPEED RPM		
		US Gallons	Cubic Inches	Liters	Cubic Centimeters	Imperial Gallons	'V' BELT DRIVE								
							Clutch #1		Clutch #2		Clutch #3			FLAT RIBBED Drive	
PSI	BAR	PSI	BAR	PSI	BAR	PSI	BAR	PSI	BAR	PSI	BAR				
P16	45	.0038	.878	.0144	14.39	.0031	3000	207	3000	207	3000	207	3000	207	3600
P16	65	.0055	1.270	.0208	20.83	.0045	3000	207	3000	207	3000	207	3000	207	3600
P16	85	.0072	1.663	.0273	27.27	.0060	2800	193	3000	207	3000	207	3000	207	3400
P16	100	.0085	1.964	.0321	32.21	.0070	2400	165	3000	207	3000	207	3000	207	3300
P16	115	.0097	2.241	.0367	36.75	.0080	2000	138	2900	200	3000	207	2900	200	3100
P16	150	.0127	2.934	.0481	48.11	.0105	1500	103	2600	179	3000	207	2600	179	2800
P16	180	.0152	3.511	.0575	57.57	.0125	1200	83	2100	145	2200	152	2100	145	2500
P16	200	.0169	3.904	.0639	63.94	.0140	1100	76	1900	131	2000	138	1900	131	2200

All data based on SAE 10W oil at 150°F.
 Available with Viton Seals for use with phosphate ester base fluids.

CAUTION: "Inlet vacuum" should not exceed 5" Hg at normal operating speed and temperature.
 Operation of pumps in excess of 5" Hg requires factory approval.

When sizing pumps, refer to the performance charts in the back of the catalog to determine the volumetric efficiency and input horsepower requirements.

How To Order

'A' denotes counterclockwise rotation
 'C' denotes clockwise rotation
 When viewed from drive shaft end

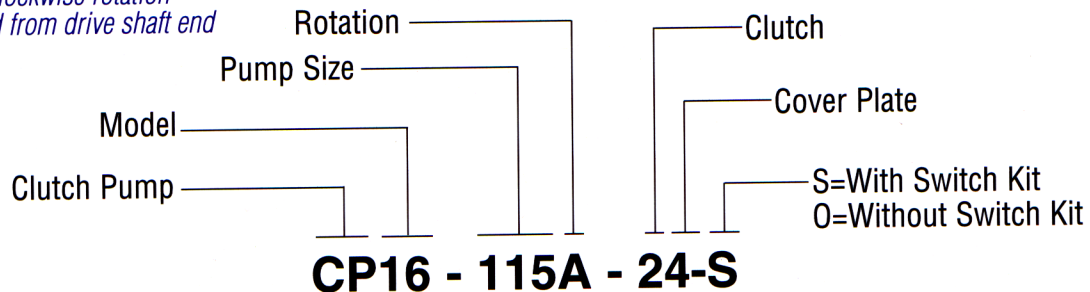

Note: Add prefix 'V' to pump model number (VCP16) when ordering pumps with Viton Seals for use with phosphate ester base fluids.

Cover Plates Available

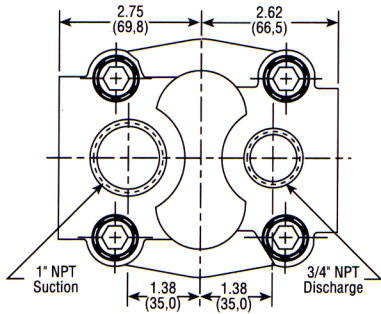
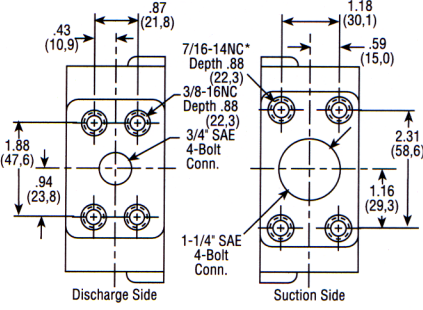
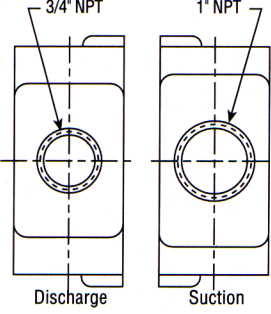
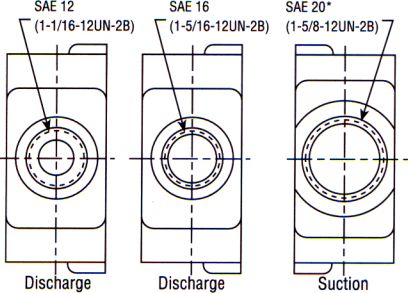
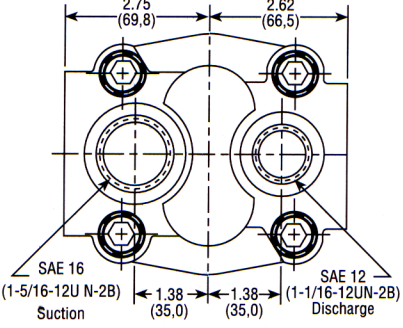
<p>2 Rear Ported NPTF</p> <p>7 Rear Ported BSPT</p>  <p>1" NPT Suction</p> <p>3/4" NPT Discharge</p>	<p>3 Side Ported SAE 4-Bolt</p>  <p>Discharge Side</p> <p>Suction Side</p> <p>*Metric threads are available – Consult factory SAE 4-Bolt NPT Connectors Are Available. See Accessory Section</p>
<p>4 Side Ported NPTF</p> <p>8 Side Ported BSPT</p>  <p>3/4" NPT Discharge</p> <p>1" NPT Suction</p>	<p>5 Side Ported Straight Thread SAE 12 Discharge</p> <p>9 Side Ported Straight Thread SAE 16 Discharge</p>  <p>Discharge</p> <p>Discharge</p> <p>Suction</p>
<p>6 Rear Ported Straight Thread</p>  <p>SAE 16 (1-5/16-12UN-2B) Suction</p> <p>SAE 12 (1-1/16-12UN-2B) Discharge</p> <p>* These dimensions locate C of bolt pattern only</p>	



See "General Product & Safety Information" on inside front cover of this catalog



Dimensional Data

Clutch No. 1 & 2

'V' Belt Drive

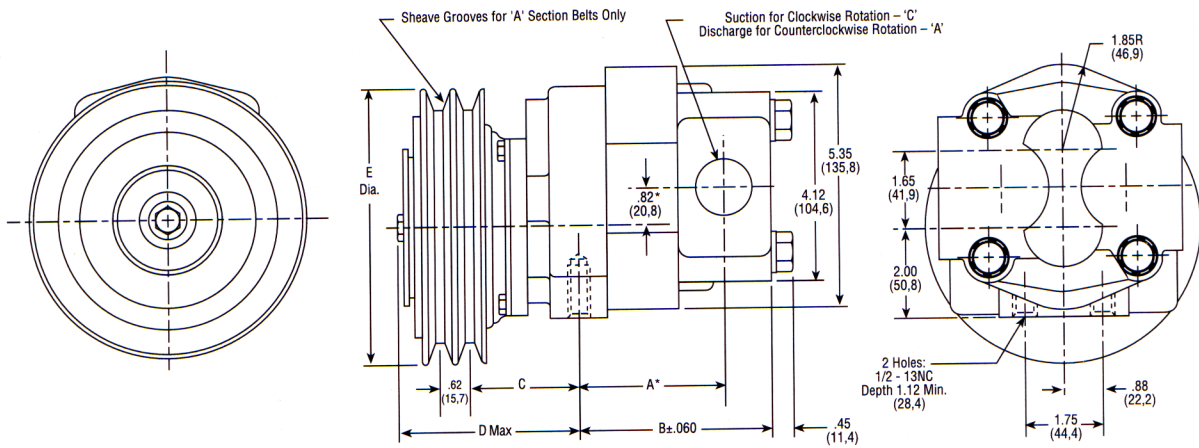

Clutch No. 3

Direct Drive

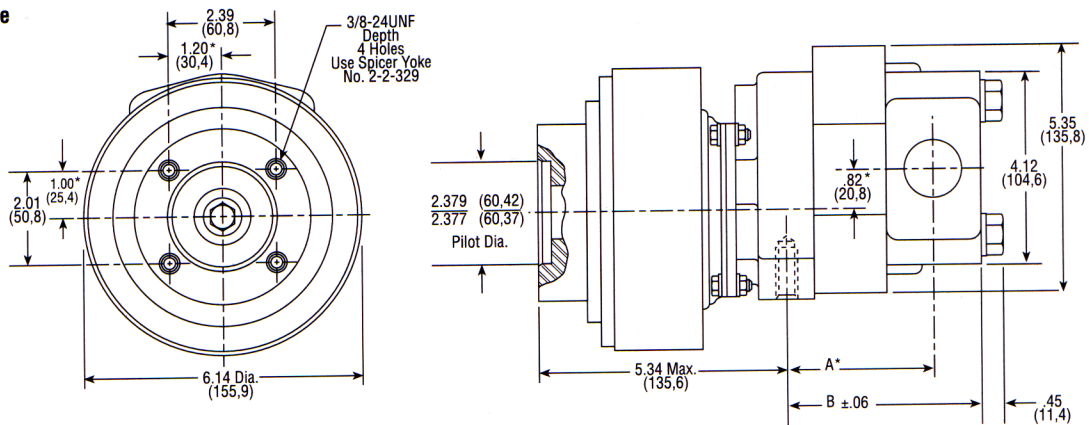

Clutch No. 4

Flat Ribbed Belt Drive

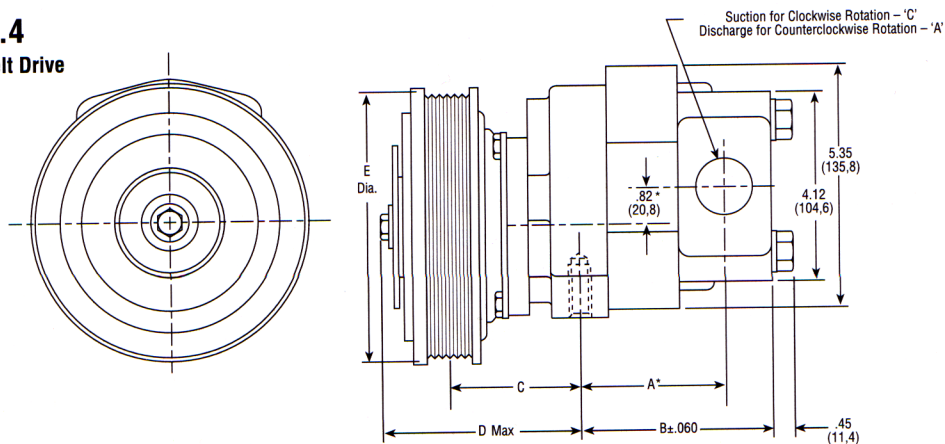

See "General Product & Safety Information" on inside front cover of this catalog



Dimensional Data

Mounting Dimensions

PUMP SIZES	WITH CLUTCH #1					WITH CLUTCH #2		
	A	B	C	D	E	C	D	E
P16-45	2.53 (64,3)	3.54 (89,9)	2.41 (61,2)	3.96 (100,6)	6.12 (155,5)	2.38 (60,5)	4.07 (103,4)	6.71 (170,4)
P16-65	2.74 (69,6)	3.75 (95,3)	2.41 (61,2)	3.96 (100,6)	6.12 (155,5)	2.38 (60,5)	4.07 (103,4)	6.71 (170,4)
P16-85	2.96 (75,2)	3.97 (100,8)	2.41 (61,2)	3.96 (100,6)	6.12 (155,5)	2.38 (60,5)	4.07 (103,4)	6.71 (170,4)
P16-100	3.12 (79,3)	4.13 (104,9)	2.41 (61,2)	3.96 (100,6)	6.12 (155,5)	2.38 (60,5)	4.07 (103,4)	6.71 (170,4)
P16-115	3.28 (83,3)	4.29 (109,0)	2.41 (61,2)	3.96 (100,6)	6.12 (155,5)	2.38 (60,5)	4.07 (103,4)	6.71 (170,4)
P16-150	3.65 (92,7)	4.66 (118,4)	2.41 (61,2)	3.96 (100,6)	6.12 (155,5)	2.38 (60,5)	4.07 (103,4)	6.71 (170,4)
P16-180	3.97 (100,8)	4.98 (126,5)	2.41 (61,2)	3.96 (100,6)	6.12 (155,5)	2.38 (60,5)	4.07 (103,4)	6.71 (170,4)
P16-200	4.18 (106,2)	5.19 (131,8)	2.41 (61,2)	3.96 (100,6)	6.12 (155,5)	2.38 (60,5)	4.07 (103,4)	6.71 (170,4)

Mounting Dimensions

PUMP SIZES	With Clutch #4					Shipping Weights (Approximate)							
	A	B	C	D	E	Clutch #1		Clutch #2		Clutch #3		Clutch #4	
						Lbs.	Kgs.	Lbs.	Kgs.	Lbs.	Kgs.	Lbs.	Kgs.
P16-45	2.53 (64,3)	3.54 (89,9)	3.05 (77,5)	4.07 (103,4)	5.75 (146,0)	18.5	8.4	22.5	10.2	28.6	13.0	22.5	10.2
P16-65	2.74 (69,6)	3.75 (95,3)	3.05 (77,5)	4.07 (103,4)	5.75 (146,0)	19.5	8.8	23.5	10.7	29.6	13.4	23.5	10.7
P16-85	2.96 (75,2)	3.97 (100,8)	3.05 (77,5)	4.07 (103,4)	5.75 (146,0)	20.5	9.3	24.5	11.1	30.6	13.9	24.5	11.1
P16-100	3.12 (79,3)	4.13 (104,9)	3.05 (77,5)	4.07 (103,4)	5.75 (146,0)	21.5	9.8	25.5	11.6	31.6	14.3	25.5	11.6
P16-115	3.28 (83,3)	4.29 (109,0)	3.05 (77,5)	4.07 (103,4)	5.75 (146,0)	22.5	10.2	26.5	12.0	32.6	14.8	26.5	12.0
P16-150	3.65 (92,7)	4.66 (118,4)	3.05 (77,5)	4.07 (103,4)	5.75 (146,0)	23.5	10.7	27.5	12.5	33.6	15.2	27.5	12.5
P16-180	3.97 (100,8)	4.98 (126,5)	3.05 (77,5)	4.07 (103,4)	5.75 (146,0)	25.5	11.6	29.5	13.4	35.6	16.1	29.5	13.4
P16-200	4.18 (106,2)	5.19 (131,8)	3.05 (77,5)	4.07 (103,4)	5.75 (146,0)	26.5	12.0	30.5	13.8	36.6	16.6	30.5	13.8

*These dimensions locate ϕ of bolt pattern only.

Operating Notes

1. Detailed installation and operating instructions are included in each clutch-pump package. Consult those instructions before installation and/or operation.

2. Clutch Data:

- Clutch No. 1 – 12 V.D.C.; 4.26 amps;
2.82 ohms @ 20°C; 75 Lb. Ft.
- Clutch No. 2 – 12 V.D.C.; 4.36 amps;
2.75 ohms @ 20°C; 125 Lb. Ft.
- Clutch No. 3 – 12 V.D.C.; 4.58 amps;
2.62 ohms @ 20°C; 200 Lb. Ft.
- Clutch No. 4 – 12 V.D.C.; 4.36 amps;
2.75 ohms @ 20°C; 125 Lb. Ft.

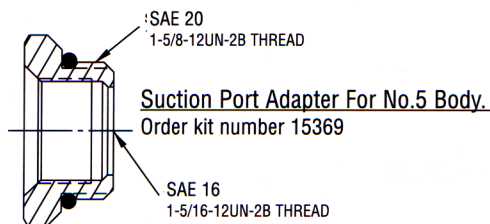

3. **Burnishing:** If full rated torque (or system pressure) is required at start-up, burnishing or cycling of the clutch will be necessary. Burnishing of the clutch can be accomplished by running the engine between 2500 and 3000 RPM and cycling the clutch on and off against the system relief valve. The relief valve should be set at 75% of the maximum pressure rating as shown in the chart on the front page of this brochure. The clutch should be cycled 50 times at a rate of 10 to 15 cycles per minute.

4. **Voltage:** The torque capability of the clutch varies with the actual voltage measured at the clutch. Do not operate at less than 11.5 volts.

5. **For maximum clutch life:** #1 #2 & #4 should be mounted to run in 'C' rotation. #3 should be mounted to run in 'A' rotation, (looking at the front of the clutch).

Electric Clutch Switch: Order Kit No. 33520

