

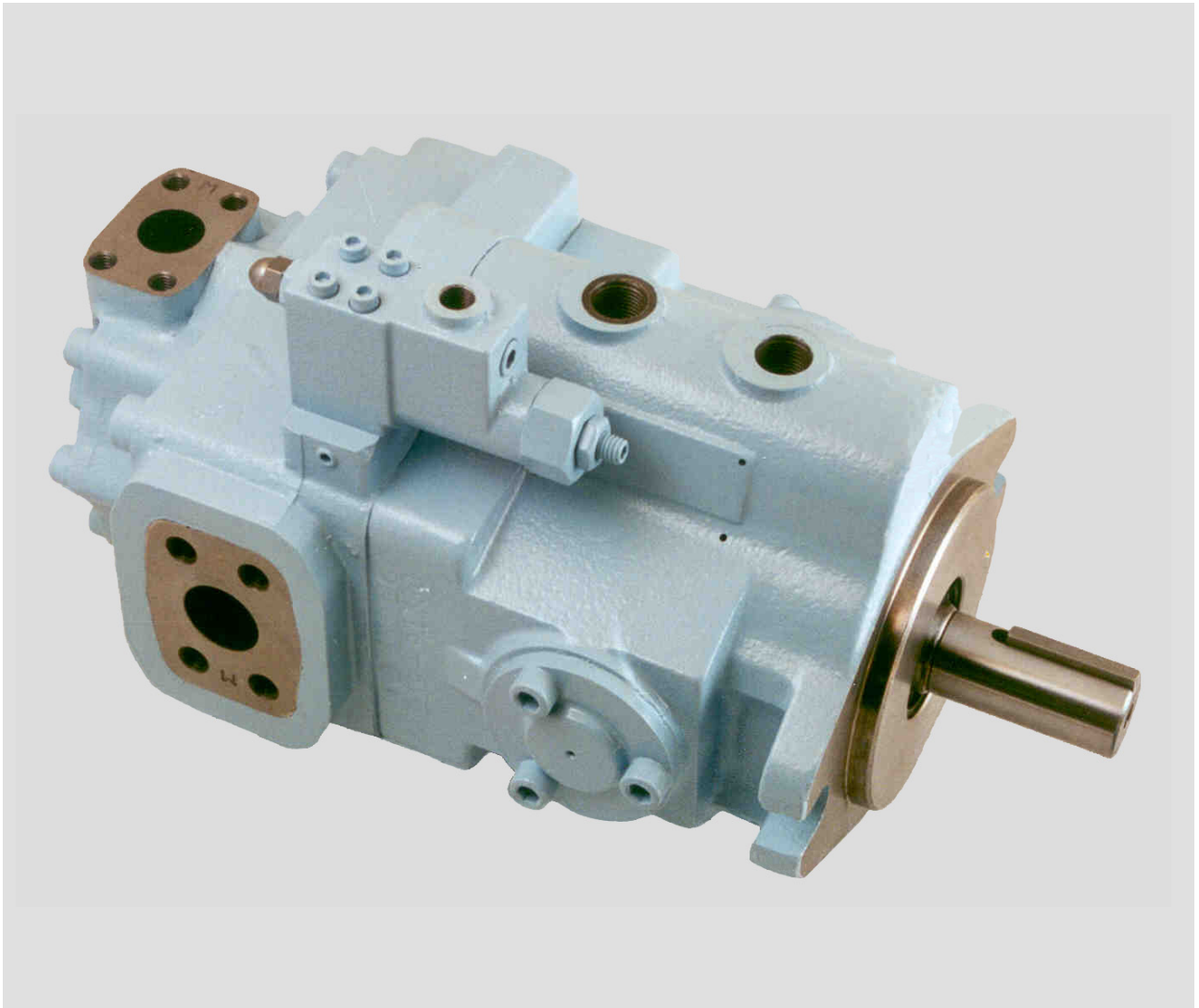

**Hybrid pump
variable & fixed flow
double & triple
T6H piston & vane pump**



Publ. 1 - AM0710 - A 12 / 2001 / FB

Replaces :

L14 - 10710 - 1

DENISON Hydraulics

CONTENTS

GENERAL	Features	3
	Instructions	3
	Minimum & maximum speeds	4
	Pressure ratings	4
	Priming at starting	4
	Minimum allowable inlet pressure	5
	General characteristics	5
	Pump selection : Routine and example	6
	Intermittent pressure rating	6
	Formulas	7
	Description	8
	Application advantages	8
	Controls C, F & L & X	9
	Hydraulic fluids	10
	Shafts	11
T6H20B - T6H20C	Ordering code & Operating characteristics	12
T6H20B - T6H20C	Dimensions	13
T6H20B	Technical data	14
T6H20C	Technical data	15
T6H29B - T6H29C	Ordering code & Operating characteristics	16
T6H29B - T6H29C	Dimensions	17
T6H29B	Technical data	18
T6H29C	Technical data	19
T6H29D	Ordering code & Operating characteristics	20
T6H29D	Dimensions	21
T6H29D	Technical data	22
T6H29DB	Ordering code & Operating characteristics	23
T6H29DB	Dimensions	24
T6H29DB	Technical data	25
T6H20B - T6H20C	Porting diagrams	26
T6H29B - T6H29C - T6H29D	Porting diagrams	26
T6H29DB	Porting diagrams	27

FEATURES

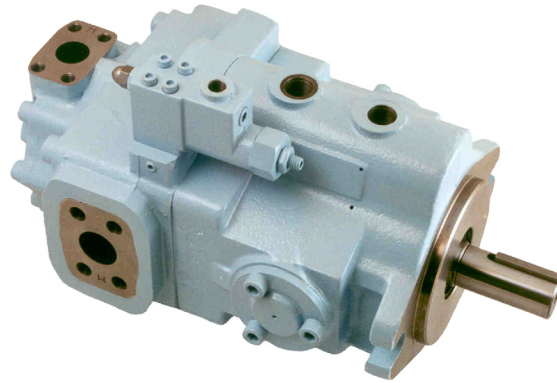

DESCRIPTION

The hybrid pump is a combination of fixed displacement vane pump B, C, D cartridges combined with a variable cartridge of PV20 or PV29 piston pump. The cartridges are driven by a common shaft without coupling in between they have a large common suction port and two or three independent outlet ports : One for the piston, one or two for the vane pump.

FEATURES

These pumps have very compact displacement and are under all actual pump sizes of the market.

GREAT FLOW

T6H20B = 2.62 in³/rev variable + .35 to 3.05 in³/rev. fixed
T6H20C = 2.62 in³/rev variable + .66 to 6.10 in³/rev. fixed
T6H29B = 3.78 in³/rev variable + .35 to 3.05 in³/rev. fixed
T6H29C = 3.78 in³/rev variable + .66 to 6.10 in³/rev. fixed
T6H29D = 3.78 in³/rev variable + 2.90 to 9.64 in³/rev. fixed
T6H29DB = 3.78 in³/rev variable + 2.90 to 9.64 in³/rev. fixed + .35 to 3.05 in³/rev. fixed

HIGH PRESSURE

Continuous pressure ratings for variable displacement units are 3500 PSI for T6H20B/C and 3000 PSI for T6H29B/C/S/DB.

This combined unit offers the advantage of low noise PV and vane pump which together increase safety and better acceptance of working conditions.

System saving because high pressure allows the use of smaller components... you can down size and gain real savings.

FLEXIBILITY

Both units fixed flow and variable flow having separated outlets allow simultaneous machine cycles eg : Mobile machine steering fonction working at the same time as the hydraulic cylinders boom functions.

- One Common suction port.
- P2 rear port 4 or 8 positions - P3 rear port 8 positions.
- Optional internal drain for variable piston pump.
- Compensator venting valve integrated.

Control options on variable displacement (piston pump).

- Compensator "C"
- Ventable pressure compensator "F"
- Load sensing compensator "L"
- Compensator with electric vent valve (only ext. drain)"X" (only T6H20B and T6H20C as standard)

Vane pump cartridge allows great flexibility with many different displacements with easy conversion or renewal.

Wide range of acceptable fluids from 7392 to 60 SUS can operate with mineral oil, biodegradable oil, and fire resistant fluids.

GENERAL APPLICATIONS INSTRUCTIONS

1. Check speed range, pressure, temperature, fluid quality, viscosity and pump rotation.
2. T6H pump case pressure should not exceed 10 PSI (see datas).
3. Check inlet conditions of the pump, if it can accept application requirement.
4. Type of shaft : if it would support operating torque.
5. Coupling must be chosen to minimize pump shaft load (weight, misalignment).
6. Filtration : must be adequate for lowest contamination level.
7. Environment of pump : to avoid noise reflection, pollution and shocks.
8. Although the T6H pumps have fast off stroke compensator reponse, system relief valves are recommended for savety considerations.

MINIMUM & MAXIMUM SPEED, PRESSURE RATINGS

Port	Size	Series	Theoretical Displacement Vi in ³ /rev.	Minimum Speed RPM	Maximum Speed		Maximum Pressure						
					HF-0, HF-1 HF-2	HF-3, HF-4 HF-5	HF-0, HF-2		HF-1, HF-4, HF-5		HF-3		
					RPM	RPM	Int. ³⁾	Cont.	Int. ³⁾	Cont.	Int. ³⁾	Cont.	
						PSI	PSI	PSI	PSI	PSI	PSI		
P1	T6H20		2.62	600	2600 ¹⁾	1800	4000	3500	2500 ²⁾	2000 ²⁾	2500	2000	
	T6H29		3.78	600	2400 ¹⁾	1800	3500	3000	2500 ²⁾	2000 ²⁾	2500	2000	
P2 or P3	B	B02	.35	600	2600	1800	4350	4000	3500	3000	2500	2000	
		B03	.66										
		B04	.78										
		B05	.97										
		B06	1.21										
		B07	1.37										
		B08	1.52										
		B10	1.94										
		B12	2.50										
		B15	3.05										
						4060	3500						
P2	C	*03	.66	600 (400) (mobile)	2600	1800	4000	3500	3000	2500	2500	2000	
		*05	1.05										
		*06	1.30										
		*08	1.61										
		*10	2.08										
		*12	2.26										
		*14	2.81										
		*17	3.56										
		*20	3.89										
		*22	4.29										
		*25	4.84										
		*28	5.42										
		*31	6.10										
						2500				2300			
		D	014	2.90	600	2400	1800	3500	3000	3000	2500	2500	2000
	017		3.55										
	020		4.00										
024	4.80												
028	5.50												
031	6.00												
035	6.80												
038	7.30												
042	8.30												
					2200								
						3000	2300			2300			

* = 0 : Industrial application = B : Industrial bi-rotational = M : Mobile application

1) See page 11 for max. pressure f(n).

2) Max. pressure HF-1 same as HF-0 and HF-2.

3) See page 6 for conditions.

HF-0, HF-2 = Antiwear Petroleum Base

HF-1 = Non Antiwear Petroleum Base

HF-5 = Synthetic Fluids

HF-3 = Water in oil Emulsions

HF-4 = Water Glycols

For further information or if the performance characteristics outlined above do not meet your own particular requirements, please consult your local DENISON Hydraulics office.

PRIMING AT STARTING

At first start operation of the pump, run it at the lowest speed and at the lowest pressure to obtain priming. When a pressure relief valve is used at the outlet it should be backed off to minimize return pressure.

An air bleed off should be provided in the circuit to facilitate the priming.

Never operate pump shaft at top speed and pressure without checking for completion of pump priming, and that the fluid is not aerated.

Always fill the housing of the T6H with oil of circuit prior to start up.

MINIMUM ALLOWABLE INLET PRESSURE (PSI ABSOLUTE)

Cartridge		Speed RPM							Series						
Size	Series	1200	1500	1800	2100	2200	2400	2600							
	T6H20	11.6	11.6	11.6	11.6	11.6	12.3	13.1	T6H20						
	T6H29	11.6	11.6	11.6	12.5	14.5	15.1		T6H29						
B	B02	11.6	11.6	11.6	11.6	11.6	11.6	11.6	B02						
	B03								B03						
	B04								B04						
	B05								B05						
	B06								B06						
	B07								B07						
	B08								B08						
	B10								B10						
	B12							B12							
	B15						12.2	B15							
C	*03	11.6	11.6	11.6	11.6	11.6	11.6	13.1	*03						
	*05								*05						
	*06								*06						
	*08								*08						
	*10								*10						
	*12								*12						
					*14					12.3	13.3	*14			
					*17				12.3		13.8	*17			
					*20					13.1		*20			
					*22				12.3	13.1		14.2	*22		
					*25				13.1	13.8	13.8		*25		
					*28					14.2	14.2		*28		
	*31				12.3	13.1	14.5		*31						
D	014	11.6	11.6	11.6	11.6	12.8	13.8	14.5	014						
	017				017										
	020				020										
					024						11.9			16.0	024
					028						12.3	13.3	14.5	17.1	028
					031						13.1	13.8		17.8	031
				035			13.3	14.2	14.8	18.7	035				
				038			13.8	14.5	15.2		038				
				042				14.8	15.7		042				
				045		12.3	14.2	15.2			045				
				050			14.8	15.8			050				
T6H20	Max. case P (PSI relative)	10.0	10.0	10.	4.9	4.9	4.9	4.9	T6H20						
T6H29		10.0	10.0	10.0	4.9	4.9	4.9		T6H29						

Vane cartridge : Inlet pressure is measured at inlet flange with petroleum base fluids at viscosity between 60 and 300 SUS. The difference between inlet pressure (at the pump flange) and atmospheric pressure must not exceed 2.9 PSI absolute to prevent aeration.

Piston cartridge : Rapid compensation at high speeds can cause severe case spikes. If the pump feeds into a blocked center valve that close quickly, use both case drain ports and direct short case drain lines and a relief valve.

Multiply absolute pressure by 1,25 for HF-3, HF-4 fluids.

by 1,35 for HF-5 fluid.

by 1,10 for ester or rapeseed base.

GENERAL CHARACTERISTICS

	Mounting standard	Weight without connector and bracket - Lbs	Moment of inertia lb. in ²	SAE 4 bolts J518c ISO/DIS 6162-1 or 6162-2			
				Suction	Pressure P1	Pressure P2	Pressure P3
T6H20B	SAE J744c	81.6	14.6	2"1/2	1"1/4	3/4" or 1"	
T6H20C	ISO-3019-1 - SAE B 101-2	81.6	19.9				
T6H29B	SAE J744c ISO-3019-1 - SAE C 127-2	108.0	21.9				
T6H29C		108.0	23.2				
T6H29D		132.3	27.5	3"	1"1/4		
T6H29DB		158.7	28.6				3/4" or 1"

PUMP SELECTION

CALCULATION

To resolve

Volumetric displacement V_i [$\text{in}^3/\text{rev.}$]

Available flow q_{v_e} [GPM]

Input power P [HP]

Performances required - (P1 - P2)

Requested flow q_{v_e} [GPM] 15.8

Speed n [R.P.M.] 1500

Pressure p [PSI] 2200

ROUTINE AND EXAMPLE

Routine :

Example :

1. First calculation $V_i = \frac{231 Q}{n}$

$$V_i = \frac{231 \times 15.8}{1500} = 2.43 \text{ in}^3/\text{rev.}$$

2. Choice V_i of each section of pump immediately greater

P1 = Piston cartridge T6H20

P2 = Vane cartridge (see tabulation) then the pump will be

P1 = T6H20 $V_i = 2.62 \text{ in}^3/\text{rev.}$

P2 = C 014 $V_i = 2.81 \text{ in}^3/\text{rev.}$
T6H20C - 014

3. Theoretical flow of this pump

$$q_{v_i} = \frac{V_i \times n}{231}$$

$$P1 = q_{v_i} = \frac{2.62 \times 1500}{231} = 17 \text{ GPM}$$

$$P2 = q_{v_i} = \frac{2.81 \times 1500}{231} = 18.2 \text{ GPM}$$

4. Available flow

P1 - Consult the curve "Full flow"

P2- Find q_{v_s} leakage function of pressure $q_{v_s} = f(p)$ on curve at 60 or 115 SUS

$$q_{v_e} = q_{v_i} - q_{v_s}$$

P1 = 1500 R.P.M. at 2200PSI = 16.4 GPM
T6H20C (page 12) :

P2 = $q_{v_s} = 1.3 \text{ GPM}$ at 2200 PSI, 115 SUS

$$P2 = q_{v_e} = 18.2 - 1.3 = 16.9 \text{ GPM}$$

5. Theoretical input power

P1 = Piston section - Consult curve

$$P2 = \frac{q_{v_i} \times p}{1714}$$

T6H20C (page 12)

P1 - Curve "Inlet horsepower"

1500 R.P.M. at 2200 PSI = 24.1 HP

$$P2 = \frac{18.2 \times 2200}{1714} = 23.3 \text{ HP}$$

6. Find P_s hydrodynamic power loss on curve

T6H20C (page12) : P_s at 1500 R.P.M., 2200 PSI = 2.0 HP

7. Total input power

$$P = P(P1) + P(P2) + P_s$$

$$P = 24.1 + 23.3 + 2.0 = 49.4 \text{ HP}$$

8. Results

T6H20C - 014

P1	P2
$V_i = 2.62 \text{ in}^3/\text{rev}$	$2.81 \text{ in}^3/\text{rev}$
$q_{v_e} = 16.4 \text{ GPM}$	16.9 GPM

Input horsepower $P = 49.4 \text{ HP}$

INTERMITTENT PRESSURE RATING

Piston cartridge section (P1) may be operated at an intermittent pressure but 10 % of operation time only, not exceeding 6 successive seconds.

Vane cartridge section units may be operated intermittently at pressures higher than the recommended continuous rating when the time weighted average of pressure is less than or equal to the continuous duty pressure rating.

This intermittent pressure rating calculation is only valid if other parameters; speed, fluid, viscosity and contamination level are respected.

For total cycle time higher than 15 minutes please consult your DENISON Hydraulics representative.

Example : T6H20C - 014

P2 - Duty cycle 4 min. at 4000 PSI

1 min. at 500 PSI

5 min. at 2300 PSI

$$\frac{(4 \times 4000) + (1 \times 500) + (5 \times 2300)}{10} = 2800 \text{ PSI}$$

2800 PSI is lower than 3500 PSI allowed as continuous pressure for T6H20C - 014 with HF-0 fluid.

FORMULAS

FLUID POWER FORMULAS

<i>Pump input torque</i>	<i>lbs. in.</i>	$\frac{\text{pressure (PSI)} \times \text{displacement (in}^3/\text{rev)}}{2 \pi \times \text{mech. eff.}}$
<i>Pump input power</i>	<i>HP</i>	$\frac{\text{speed (rpm)} \times \text{displacement (in}^3/\text{rev)} \times \text{pressure (PSI)}}{395934 \times \text{overall eff.}}$
<i>Pump output flow</i>	<i>U.S. gpm</i>	$\frac{\text{speed (rpm)} \times \text{displacement (in}^3/\text{rev)} \times \text{volumetric eff.}}{231}$
<i>Fluid motor speed</i>	<i>rpm</i>	$\frac{231 \times \text{flow rate (U.S. gpm)} \times \text{volumetric eff.}}{\text{displacement (in}^3/\text{rev.)}}$
<i>Fluid motor torque</i>	<i>lbs. in.</i>	$\frac{\text{pressure (PSI)} \times \text{displacement (in}^3/\text{rev)} \times \text{mech. eff.}}{2 \pi}$
<i>Fluid motor power</i>	<i>HP</i>	$\frac{\text{speed (rpm)} \times \text{displacement (in}^3/\text{rev)} \times \text{pressure (PSI)} \times \text{overall eff.}}{395934}$

DESCRIPTION

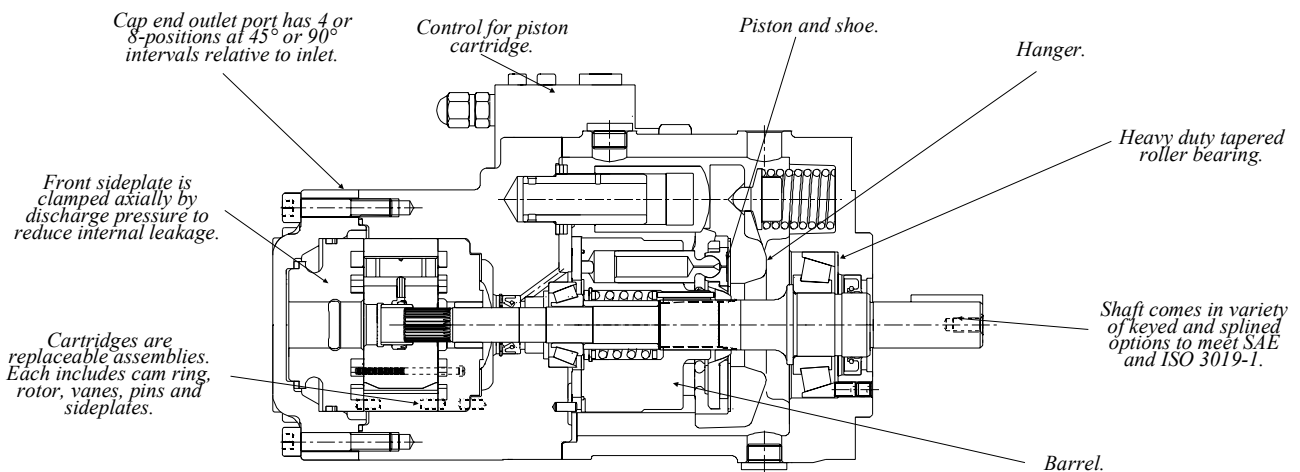

MOBILE VERSION

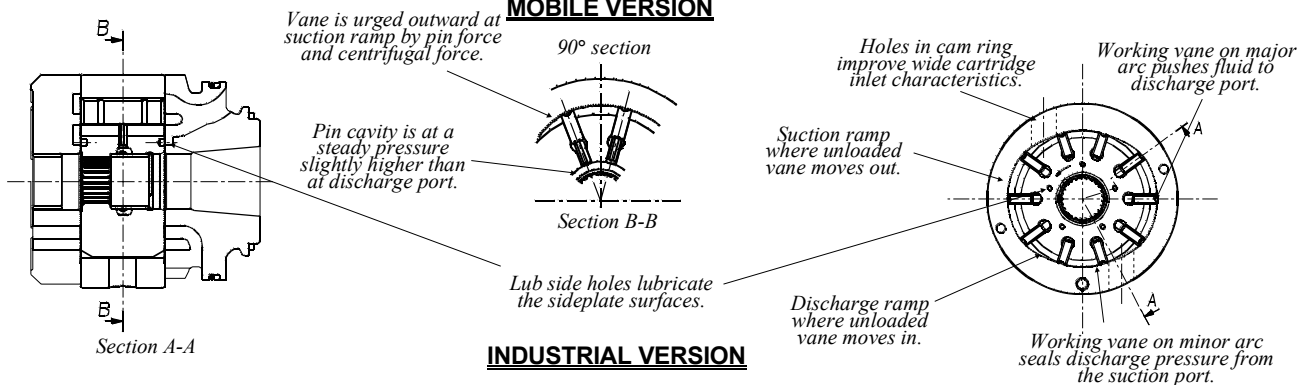

INDUSTRIAL VERSION

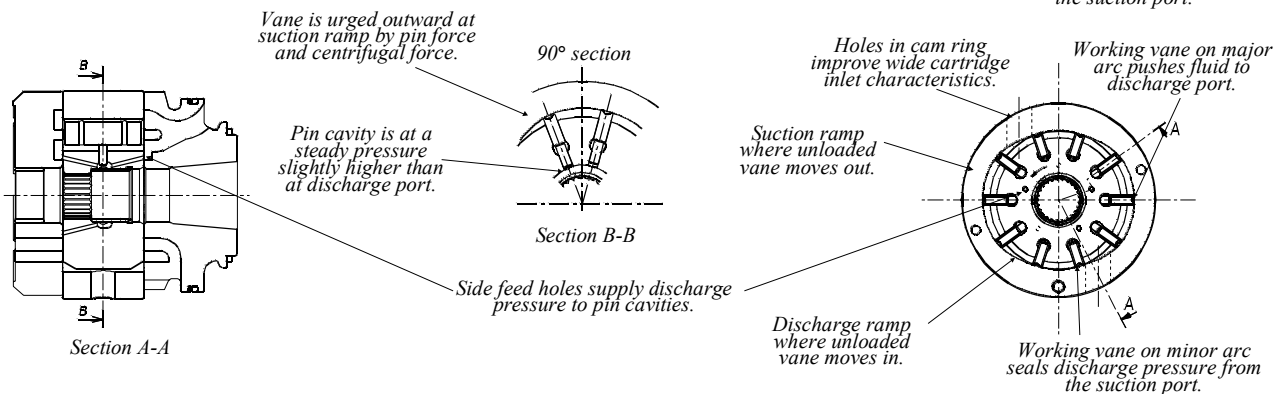

APPLICATION ADVANTAGES

- The high pressure capability to 3500 PSI, in the small envelope, reduces installation costs and provides extended life at reduced pressure.
- The high volumetric efficiency, typically 94%, reduces heat generation, and allows speeds down to 600 RPM (400 RPM for mobile) at full pressure.
- The high mechanical efficiency, typically 94%, reduces energy consumption.
- The wide speed range from 600 RPM to 2600 RPM (400 RPM to 2600 RPM for mobile), combined with large size cartridge displacements, will optimize operation for the lowest noise level in the smallest envelope.
- The low speed 600 RPM (400 RPM for mobile), low pressure, high viscosity 3900 SUS (7400 SUS for mobile) allow application in cold environments with minimum energy consumption and without seizure risk.
- The low ripple pressure ± 29 PSI reduces piping noise and increases life time of other components in the circuit.
- The high resistance to particle contamination because of the double lip vane increases pump life.
- The large variety of options (cam displacement, shaft, porting, piston section controls) allows customized installation.

C - COMPENSATOR

The "C" and "F" pressure compensator control allows the pump to deliver full volume from the outlet port until the pressure rise to the value set by the control. The control then reduces the pump volume to that required by the system mobile maintaining the preset pressure at the outlet port.

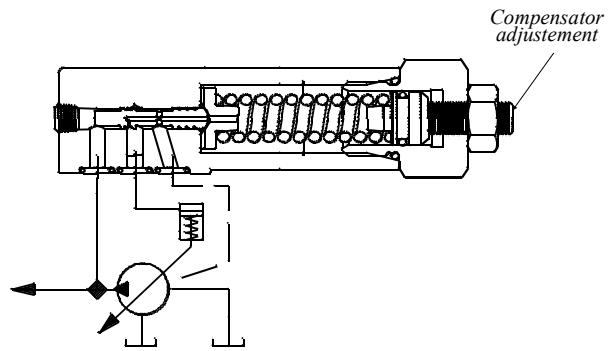

F - VENTABLE COMPENSATOR

The "F" compensator is used in applications requiring remote control pressure. The remote relief is connected to the vent port. The pressure may be controlled at any level below the compensator pressure setting. The vent port may also be used to remotely vent-off the compensator for starting.

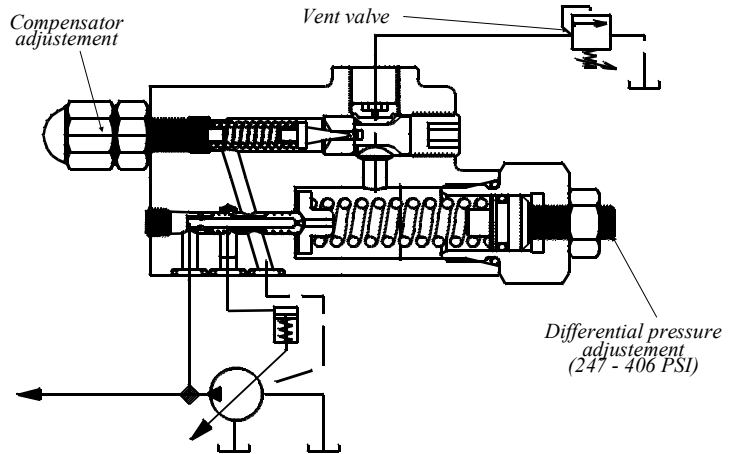

L - LOAD SENSING COMPENSATOR

The "L" compensator is used for load sensing circuits and is a true load sensor. This is the "F" compensator with a pin in the compensator spool (see enlarged view). The pin prevents pilot flow from entering the circuit which will eliminate creeping of the load. The "L" compensator will let the pump deliver a constant flow rate to the circuit by providing an adjustable ΔP across the customer's orifice or valve. The pump will operate at 247 - 406 PSI above "Load Pressure".

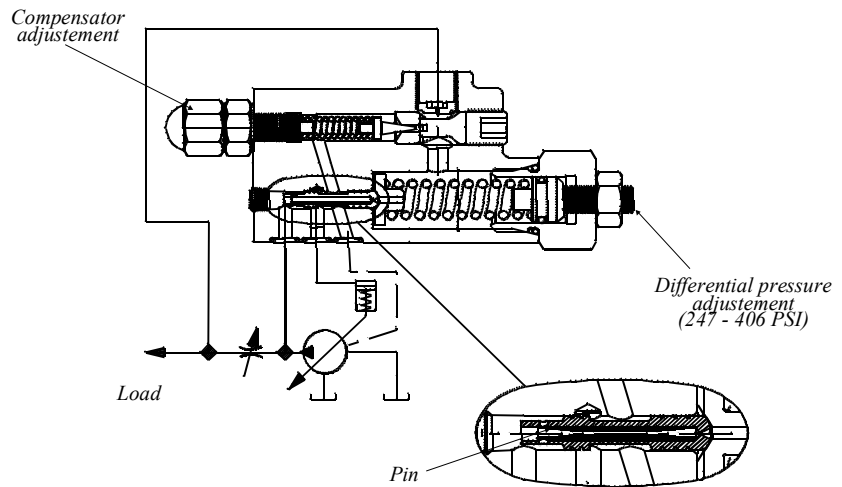

X - VENTED COMPENSATOR BY ELECTRIC VALVE

The "X" compensator is used in application requiring vent off on compensator at starting or at other time of the cycle. The piston cartridge reduce the volume for maintaining the pressure at the differential pressure sitting.

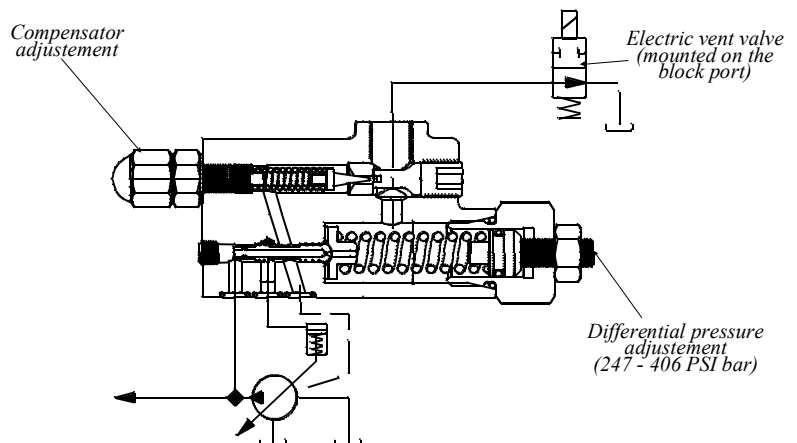

FLUIDS

RECOMMENDED FLUIDS

Petroleum based antiwear R & O fluids.
 These fluids are the recommended fluids for T6 series pumps. Maximum catalog ratings and performance data are based on operation with these fluids. These fluids are covered by DENISON Hydraulics HF-0 and HF-2 specification.

ACCEPTABLE ALTERNATE FLUIDS

The use of fluids other than petroleum based antiwear R & O fluids, requires that the maximum ratings of the pumps will be reduced. In some cases the minimum replenishment pressures must be increased. Consult specific sections for more details.

VISCOSITY

Max (cold start, low speed & pressure) _____ 3900 (SUS)
 Max (cold start, low speed & pressure) (for mobile) _____ 7400 (SUS)
 Max (full speed & pressure) _____ 500 (SUS)
 Optimum (max. life) _____ 140 (SUS)
 Min (full speed & pressure for HF-1, HF-3, HF-4 & HF-5 fluids) _____ 90 (SUS)
 Min (full speed & pressure for HF-0 & HF-2 fluids) _____ 60 (SUS)

VISCOSITY INDEX

90° min. higher values extend range of operating temperatures.
 Maximum fluid temperature (θ) °F
 HF-0, HF-1, HF-2 _____ + 212°
 HF-3, HF-4 _____ + 122°
 HF-5 _____ + 158°
 Biodegradable fluids (esters & rapeseed base) _____ + 149°

 Minimum fluid temperature (θ) °F
 HF-0, HF-1, HF-2, HF-5 _____ - 0.4°
 HF-3, HF-4 _____ + 50°
 Biodegradable fluids (esters & rapeseed base) _____ - 4.4°

FLUID CLEANLINESS

The fluid must be cleaned before and during operation to maintain contamination level of NAS 1638 class 8 (or ISO 18/14) or better. Filters with 25 micron (or better, β10 ≥ 100) nominal ratings may be adequate but do not guarantee the required cleanliness levels. Suction strainers must be of adequate size to provide minimum inlet pressure specified. 100 mesh (149 micron) is the finest mesh recommended. Use oversize strainers or omit them altogether on applications which require cold starts or use fire resistant fluids.

OPERATING TEMPERATURES AND VISCOSITIES

Operating temperatures are a function of fluid viscosities, fluid type, and the pump. Fluid viscosity should be selected to provide optimum viscosity at normal operating temperatures. For cold starts the pumps should be operated at low speed and pressure until fluid warms up to an acceptable viscosity for full power operation.

WATER CONTAMINATION IN THE FLUID

Maximum acceptable content of water.
 • 0,10 % for mineral base fluids.
 • 0,05 % for synthetic fluids, crankcase oils, biodegradable fluids.
 If amount of water is higher then it should be drained off the circuit.

SHAFTS

SHAFTS COUPLINGS AND FEMALE SPLINES SPLINES

- The shafts will accept a maximum misalignment of .003 TIR when the pump is foot mounted and .0015" when flange mounted. The angular alignment of two spline axes must be less than 0,1° (.0001" /mm).
- The coupling spline must be lubricated with a lithium molydisulfide grease or a similar lubricant.
- The coupling must be hardened to a hardness between 27 and 45 R.C.
- The female spline must be made to conform to the Class 1 fit as described in SAE-J498b (1971). This is described as a Flat Root Side Fit.

KEYED SHAFTS

DENISON Hydraulics supplies the T6H series keyed shaft pumps with high strength heat-treated keys. Therefore, when installing or replacing these pumps, the heat-treated keys must be used in order to insure maximum life in the application. If the key is replaced it must be a heat-treated key between 27 and 34 R.C. hardness. The corners of the keys must be chamfered from .030 to .040 at 45° to clear radius in the key way.

NOTE

Alignment of keyed shafts must be within tolerances given for splined shafts.

SHAFT LOADS

These products are designed primarily for coaxial drives which do not impose axial or side loading on the shaft. Consult the typical curve below for the theoretical life. For specific applications which may include vibration and shock during operation of the machine or external load on the drive shaft. Please consult your local DENISON Hydraulics office.

SHAFT BEARING LIFE (TYPICAL) WITHOUT EXTERNAL LOAD

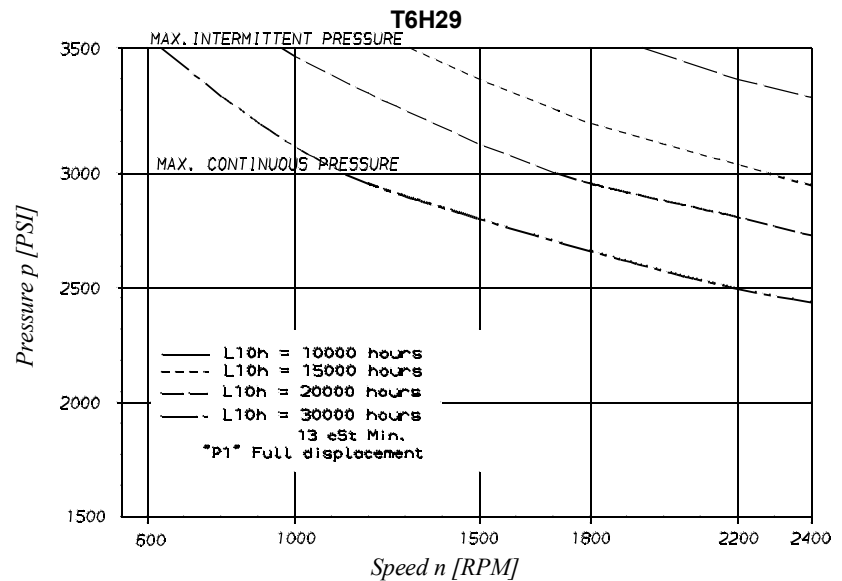
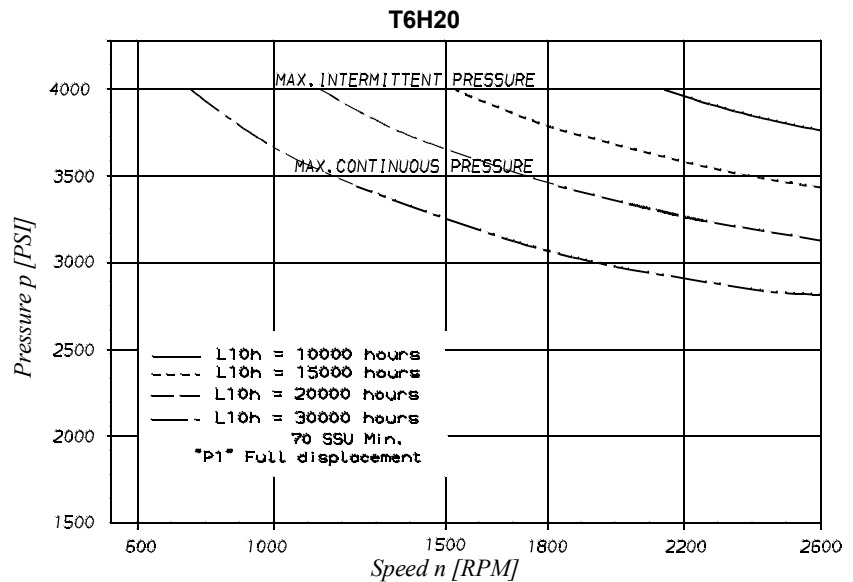

ORDERING CODE & OPERATING CHARACTERISTICS - T6H20B - T6H20C SERIES

Model No. T6H20B - B08 - 1 L 1 B - 2 F 0 M 0 - 00 -
 T6H20C - *12 - 1 L 1 C - 2 F 0 M 0 - 00 -

Series and capacity P1 (rotating group)
 2.62 in³/rev.

Cam ring P2
 (Delivery at 0 PSI & 1200 RPM)

T6H20B	T6H20C
B02 = 1.84 GPM	*03 = 3.42 GPM
B03 = 3.11 GPM	*05 = 5.45 GPM
B04 = 4.06 GPM	*06 = 6.75 GPM
B05 = 5.04 GPM	*08 = 8.37 GPM
B06 = 6.28 GPM	*10 = 10.81 GPM
B07 = 7.13 GPM	*12 = 11.76 GPM
B08 = 7.89 GPM	*14 = 14.58 GPM
B10 = 10.08 GPM	*17 = 18.48 GPM
B12 = 13.00 GPM	*20 = 20.23 GPM
B15 = 15.85 GPM	*22 = 22.29 GPM
	*25 = 25.14 GPM
	*28 = 28.15 GPM
	*31 = 31.70 GPM

Type of shaft

1 = keyed (SAE BB) 3 = splined (SAE C)
 4 = splined (SAE BB) 5 = keyed (SAE C)

Direct. of rotation (view on shaft end)

R = clockwise
 L = counter-clockwise

Seal class

1 = S1 (BUNA N)
 5 = S5 (VITON)

Design letter

B = T6H20B
 C = T6H20C

* = 0 = Indust. uni-rotational / B = Indust. bi-rotational / M = Mobile bi-rotational

Modification

Porting combination

Depend on the rotation - See page 26

Variables port

	Dia	Code
P2	1"	0
P2	3/4"	1

Variables flanges connections

4 bolts SAE flange (J518c)

0 = UNC thread

M = metric thread)

Control accessories

0 = Maxi flow

9 = 90 % maxi flow

8 = 80 % maxi flow

7 = 70 % maxi flow

6 = 60 % maxi flow

5 = 50 % maxi flow

Control

C = Compensator

F = RC pilot operated compensator

L = RC pilot operated compensator

"load sensing"

X* = RC pilot operated compensator with vent valve 24 VDC

* Use with external drain only

Connection (drain + vent.)

0 = ext. drain + UNF thread

2 = ext. drain + BSPP thread

3 = int. drain + UNF thread

4 = int. drain + BSPP thread

OPERATING CHARACTERISTICS - TYPICAL [115 SUS]

Pressure port	Series	Volumetric Displacement Vi	Flow qVe [GPM], n = 1800 RPM				Input power P [HP], n = 1800 RPM				
			p = 0 PSI	p = 2000 PSI		p = 3500 PSI		p = 100 PSI	p = 2000 PSI	p = 3500 PSI	
P2 T6H20B	B02	.35 in ³ /rev	2.76	2.33	1.80	0.74	4.02	8.10			
	B03	.60 in ³ /rev	4.66	4.23	3.70	0.85	6.24	12.93			
	B04	.78 in ³ /rev	6.09	5.66	5.13	0.94	7.90	16.55			
	B05	.97 in ³ /rev	7.56	7.13	6.60	1.02	9.62	20.29			
	B06	1.21 in ³ /rev	9.42	8.99	8.46	1.13	11.79	25.00			
	B07	1.37 in ³ /rev	10.70	10.27	9.74	1.20	13.29	28.26			
	B08	1.52 in ³ /rev	11.84	11.41	10.88	1.27	14.62	31.15			
	B10	1.94 in ³ /rev	15.12	14.69	14.16	1.46	18.45	39.48			
	B12	2.50 in ³ /rev	19.50	19.07	18.54	1.72	23.55	50.58			
	B15	3.05 in ³ /rev	23.78	23.35	22.88 ¹⁾	1.97	28.55	57.35 ¹⁾			
			p = 0 PSI		p = 2000 PSI		p = 3500 PSI		p = 100 PSI	p = 2000 PSI	p = 3500 PSI
				Indust.	Mobile	Indust.	Mobile				
P2 T6H20C	*03	.66 in ³ /rev	5.14	3.85	3.61	2.95	-	2.11	8.45	13.38	
	*05	1.05 in ³ /rev	8.18	6.89	6.65	5.99	5.56	2.29	12.00	19.59	
	*06	1.30 in ³ /rev	10.13	8.84	8.60	7.94	7.51	2.40	14.28	23.57	
	*08	1.61 in ³ /rev	12.55	11.26	11.02	10.36	9.93	2.54	17.11	28.53	
	*10	2.08 in ³ /rev	16.22	14.93	14.69	14.03	13.60	2.76	21.38	36.00	
	*12	2.26 in ³ /rev	17.64	16.35	16.11	15.45	15.02	2.84	23.05	38.92	
	*14	2.81 in ³ /rev	21.88	20.59	20.35	19.69	19.26	3.09	27.99	47.56	
	*17	3.56 in ³ /rev	27.73	26.44	26.20	25.54	25.11	3.43	34.81	59.51	
	*20	3.89 in ³ /rev	30.34	29.05	28.81	28.15	27.42	3.58	37.86	64.85	
	*22	4.29 in ³ /rev	33.43	32.14	31.90	31.24	30.81	3.76	41.47	71.16	
	*25	4.84 in ³ /rev	37.71	36.42	36.18	35.52	35.09	4.01	46.46	79.90	
	*28	5.42 in ³ /rev	42.23	40.94	40.70	40.32 ²⁾	39.94 ²⁾	4.27	51.74	76.73 ²⁾	
*31	6.10 in ³ /rev	47.56	46.27	46.03	45.65 ²⁾	45.27 ²⁾	4.58	57.95	86.06 ²⁾		

¹⁾ B15 = 4060 PSI max. int. ²⁾ 028 - 031 = 3000 PSI max. int.

- Not to use because internal leakage greater than 50% theoretical flow.

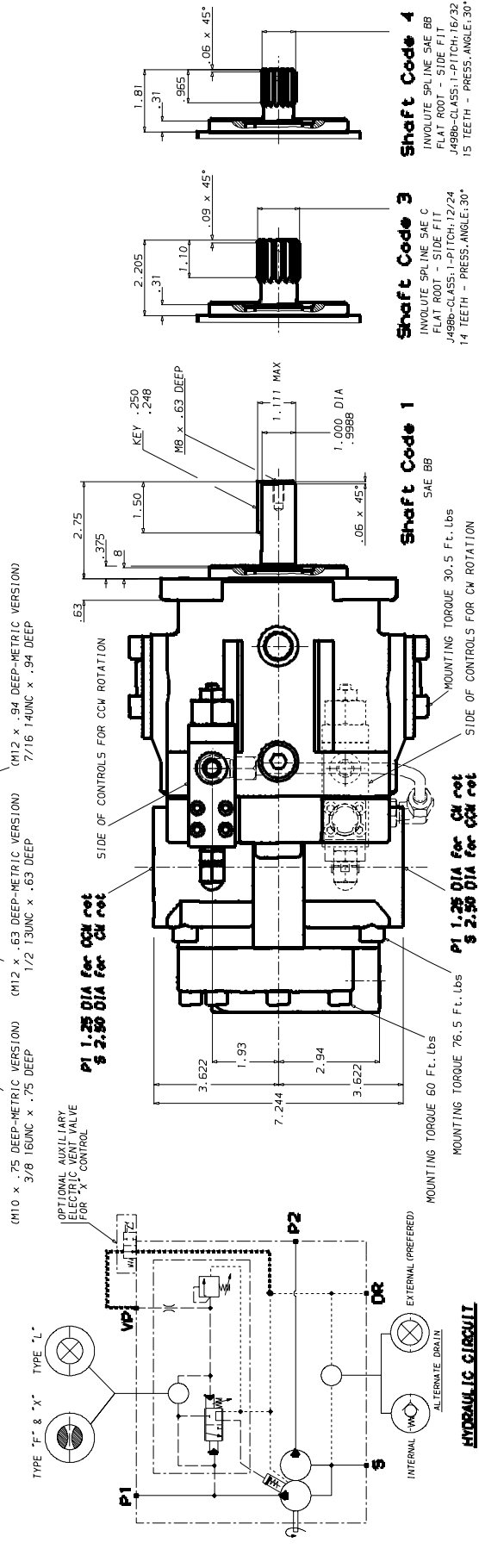
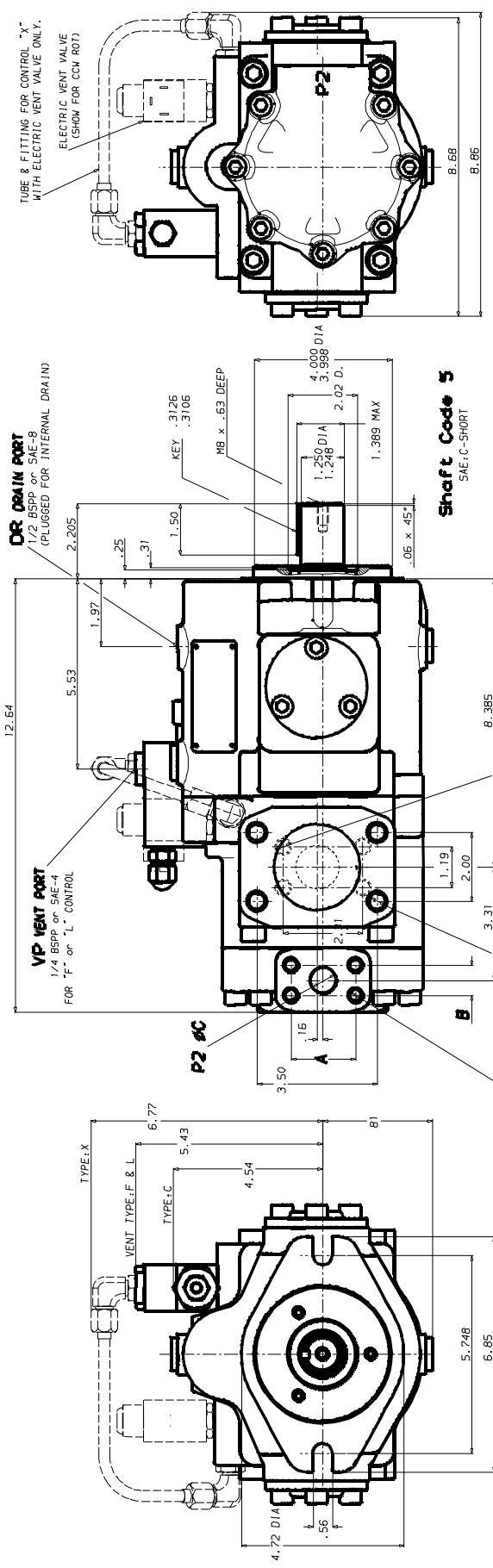

Variable port		
Port	Code	Variable port
P2	0	2.06
P2	1	1.88
		1.03
		.88
		1.00
		.75

Shaft torque limits [in ³ /rev. x PSI]	
Shaft	V i x p max.
1	18972
4	28937

**INTERNAL LEAKAGE (TYPICAL)
"P2" CARTRIDGE**

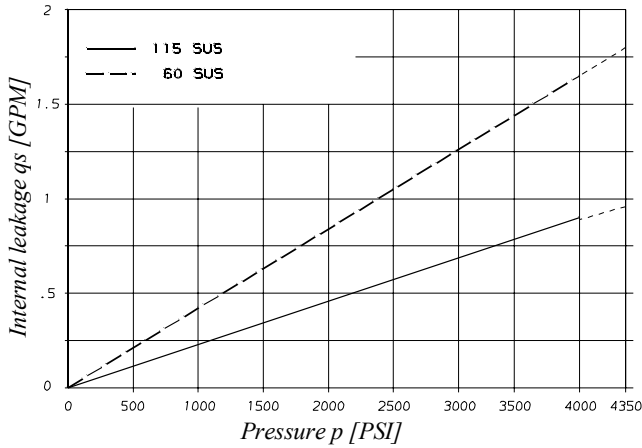

Do not operate pump more than 5 seconds at any speed or viscosity if internal leakage is higher than 50% of theoretical flow.

**NOISE LEVEL (TYPICAL)
T6H20B - B03**

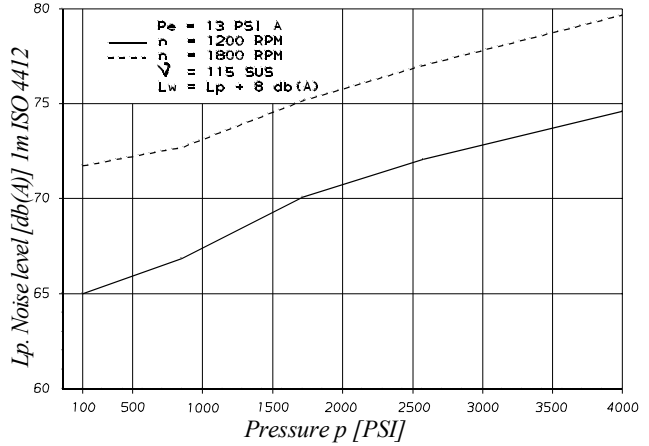

Noise level is given with each cartridge discharging at the pressure noted on the curve (P1 full flow).

**HYDROMECHANICAL POWER LOSS (TYPICAL)
"P2" CARTRIDGE**

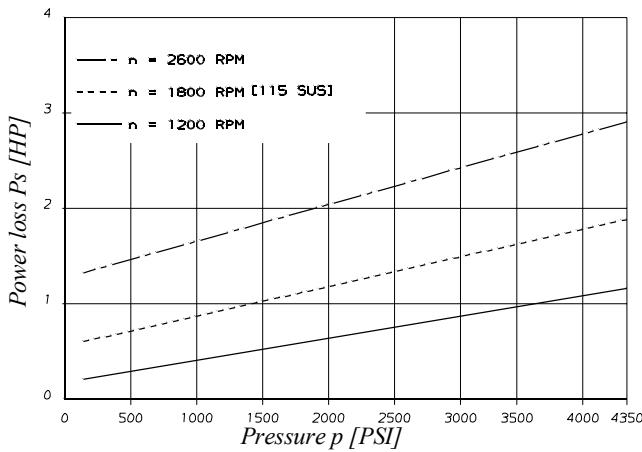

**OUTLET FLOW
"P1" CARTRIDGE**

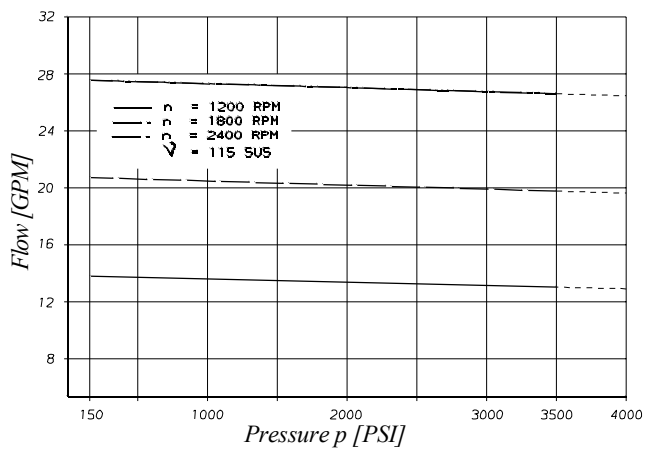

**OVERALL EFFICIENCY - "P1" CARTRIDGE
Full displacement**

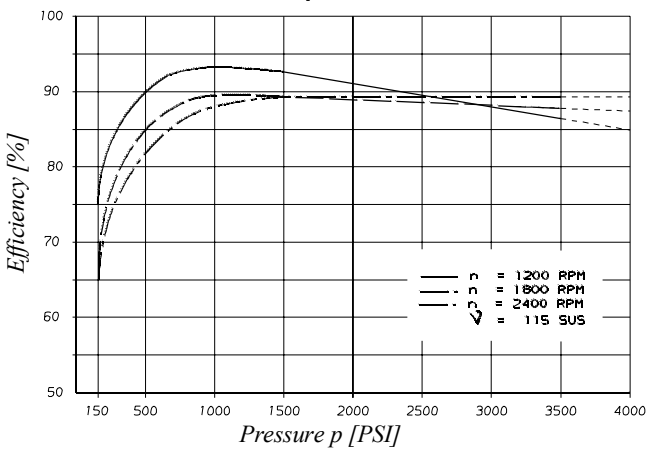

**INPUT HORSEPOWER - "P1" CARTRIDGE
Full displacement**

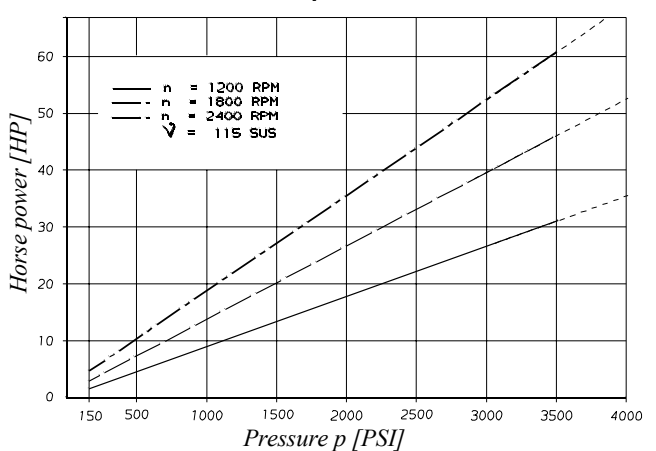

**INTERNAL LEAKAGE (TYPICAL)
"P2" CARTRIDGE**

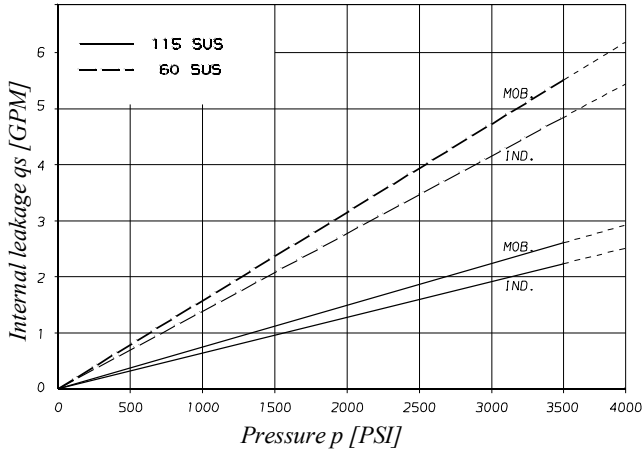

Do not operate pump more than 5 seconds at any speed or viscosity if internal leakage is higher than 50% of theoretical flow.

**NOISE LEVEL (TYPICAL)
T6H20C - B22**

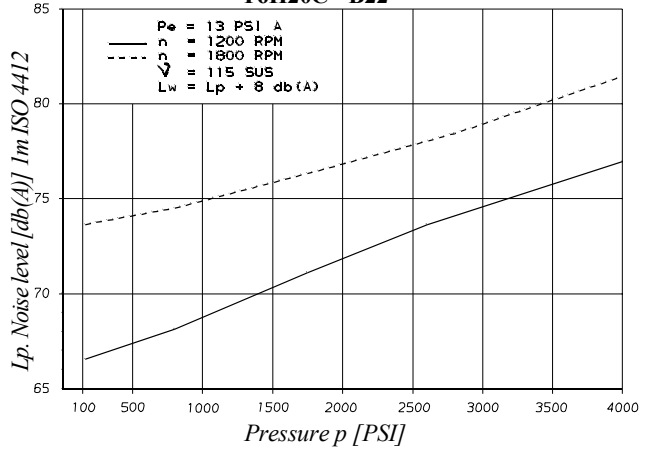

Noise level is given with each cartridge discharging at the pressure noted on the curve (P1 full flow).

**HYDROMECHANICAL POWER LOSS (TYPICAL)
"P2" CARTRIDGE**

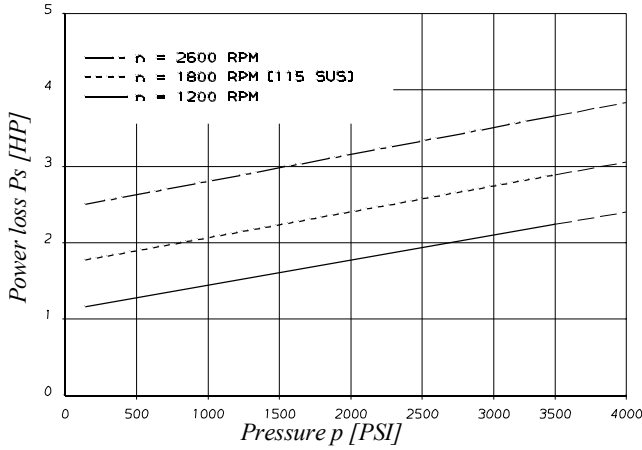

**OUTLET FLOW
"P1" CARTRIDGE**

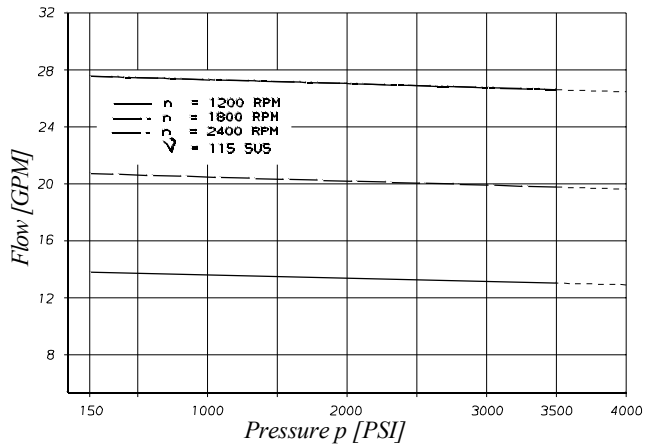

**OVERALL EFFICIENCY - "P1" CARTRIDGE
Full displacement**

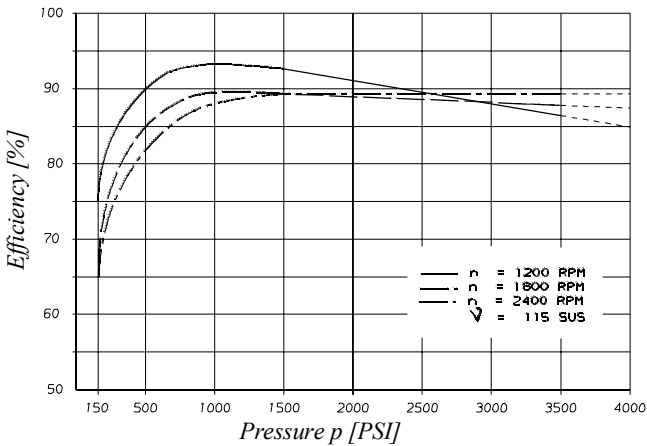

**INPUT HORSEPOWER - "P1" CARTRIDGE
Full displacement**

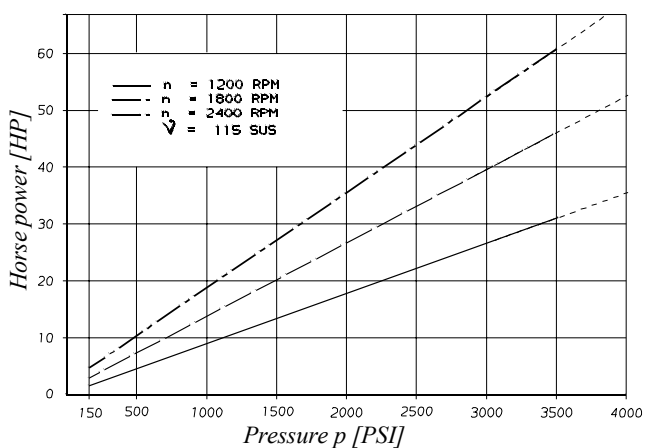

ORDERING CODE & OPERATING CHARACTERISTICS - T6H29B - T6H29C SERIES

Model No. T6H29B - B08 - 1 L 1 B - 2 F 0 M 0 - 00 -
 T6H29C - *12 - 1 L 1 B - 2 F 0 M 0 - 00 -

Series and capacity P1
 (rotating group)
 3.78 in³/rev.

Cam ring P2
 (Delivery at 0 PSI & 1200 RPM)

T6H29B	T6H29C
B02 = 1.84 GPM	*03 = 3.42 GPM
B03 = 3.11 GPM	*05 = 5.45 GPM
B04 = 4.06 GPM	*06 = 6.75 GPM
B05 = 5.04 GPM	*08 = 8.37 GPM
B06 = 6.28 GPM	*10 = 10.81 GPM
B07 = 7.13 GPM	*12 = 11.76 GPM
B08 = 7.89 GPM	*14 = 14.58 GPM
B10 = 10.08 GPM	*17 = 18.48 GPM
B12 = 13.00 GPM	*20 = 20.23 GPM
B15 = 15.85 GPM	*22 = 22.29 GPM
	*25 = 25.14 GPM
	*28 = 28.15 GPM
	*31 = 31.70 GPM

Type of shaft
 1 = keyed (SAE C)
 3 = splined (SAE C)

Direct. of rotation (view on shaft end)
 R = clockwise
 L = counter-clockwise

Seal class
 1 = S1 (BUNA N)
 5 = S5 (VITON)

Design letter

Modification

Porting combination
 Depend on the rotation - See page 26

Variable port

	Dia	Code
P2	1"	0
P2	3/4"	1

Variables flanges connections
 4 bolts SAE flange (J518c)
 0 = UNC thread
 M = metric thread

Control accessories

0 = Maxi flow
 9 = 90 % maxi flow
 8 = 80 % maxi flow
 7 = 70 % maxi flow
 6 = 60 % maxi flow
 5 = 50 % maxi flow

Control

C = Compensator
 F = RC pilot operated compensator
 L = RC pilot operated compensator
 "load sensing"

Connection (drain + vent.)

0 = ext. drain + UNF thread
 2 = ext. drain + BSPP thread
 3 = int. drain + UNF thread
 4 = int. drain + BSPP thread

* = 0 = Indust. uni-rotational / B = Indust. bi-rotational / M = Mobile bi-rotational

OPERATING CHARACTERISTICS - TYPICAL [115 SUS]

Pressure port	Series	Volumetric Displacement Vi	Flow qV _e [GPM], n = 1800 RPM				Input power P [HP], n = 1800 RPM			
			p = 0 PSI	p = 2000 PSI		p = 4350 PSI	p = 100 PSI	p = 2000 PSI	p = 4350 PSI	
P2 T6H29B	B02	.35 in ³ /rev	2.76	2.33	1.80	0.74	4.02	8.10		
	B03	.60 in ³ /rev	4.66	4.23	3.70	0.85	6.24	12.93		
	B04	.78 in ³ /rev	6.09	5.66	5.13	0.94	7.90	16.55		
	B05	.97 in ³ /rev	7.56	7.13	6.60	1.02	9.62	20.29		
	B06	1.21 in ³ /rev	9.42	8.99	8.46	1.13	11.79	25.00		
	B07	1.37 in ³ /rev	10.70	10.27	9.74	1.20	13.29	28.26		
	B08	1.52 in ³ /rev	11.84	11.41	10.88	1.27	14.62	31.15		
	B10	1.94 in ³ /rev	15.12	14.69	14.16	1.46	18.45	39.48		
	B12	2.50 in ³ /rev	19.50	19.07	18.54	1.72	23.55	50.58		
	B15	3.05 in ³ /rev	23.78	23.35	22.88 ¹⁾	1.97	28.55	57.35 ¹⁾		
			p = 0 PSI	p = 2000 PSI		p = 3500 PSI	p = 100 PSI	p = 2000 PSI	p = 3500 PSI	
				Indust.	Mobile	Indust.	Mobile			
P2 T6H29C	*03	.66 in ³ /rev	5.14	3.85	3.61	2.95	-	2.11	8.45	13.38
	*05	1.05 in ³ /rev	8.18	6.89	6.65	5.99	5.56	2.29	12.00	19.59
	*06	1.30 in ³ /rev	10.13	8.84	8.60	7.94	7.51	2.40	14.28	23.57
	*08	1.61 in ³ /rev	12.55	11.26	11.02	10.36	9.93	2.54	17.11	28.53
	*10	2.08 in ³ /rev	16.22	14.93	14.69	14.03	13.60	2.76	21.38	36.00
	*12	2.26 in ³ /rev	17.64	16.35	16.11	15.45	15.02	2.84	23.05	38.92
	*14	2.81 in ³ /rev	21.88	20.59	20.35	19.69	19.26	3.09	27.99	47.56
	*17	3.56 in ³ /rev	27.73	26.44	26.20	25.54	25.11	3.43	34.81	59.51
	*20	3.89 in ³ /rev	30.34	29.05	28.81	28.15	27.42	3.58	37.86	64.85
	*22	4.29 in ³ /rev	33.43	32.14	31.90	31.24	30.81	3.76	41.47	71.16
	*25	4.84 in ³ /rev	37.71	36.42	36.18	35.52	35.09	4.01	46.46	79.90
	*28	5.42 in ³ /rev	42.23	40.94	40.70	40.32 ²⁾	39.94 ²⁾	4.27	51.74	76.73 ²⁾
*31	6.10 in ³ /rev	47.56	46.27	46.03	45.65 ²⁾	45.27 ²⁾	4.58	57.95	86.06 ²⁾	

¹⁾ B15 = 4060 PSI max. int. ²⁾ 028 - 031 = 3000 PSI max. int.

- Not to use because internal leakage greater than 50% theoretical flow.

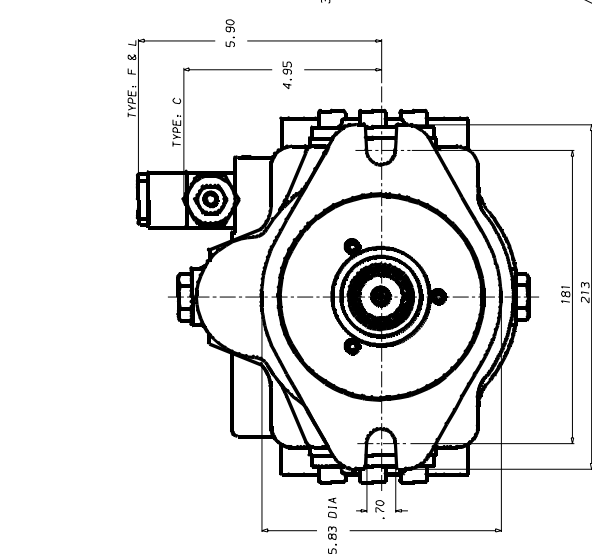
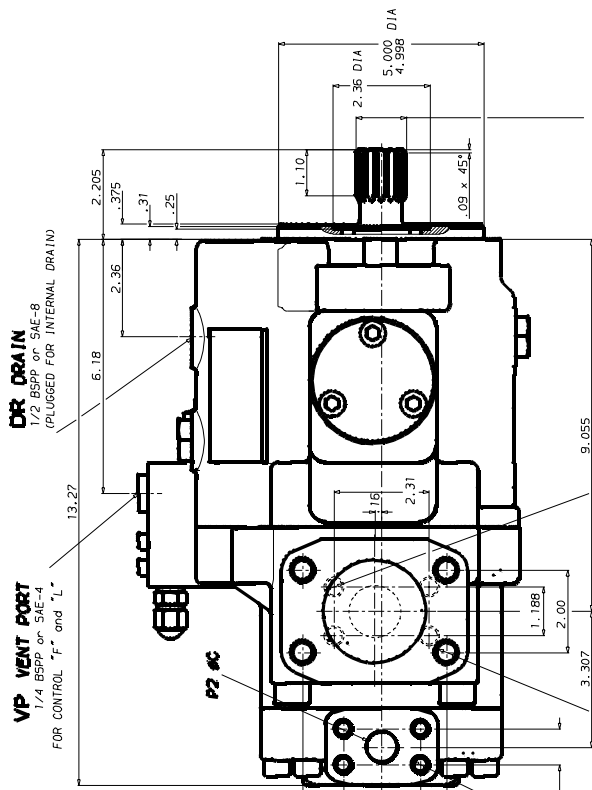
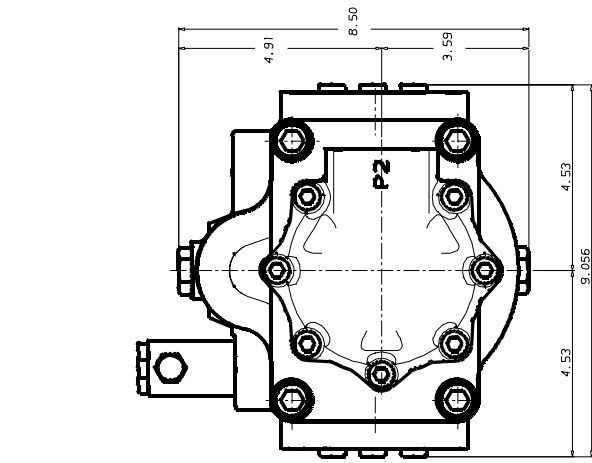

VP VENT PORT
1/4 BSPP or SAE-4
FOR CONTROL "F" and "L"

DR DRAIN
1/2 BSPP or SAE-8
(PLUGGED FOR INTERNAL DRAIN)

Shaft code 3
INVOLUTE SPLINE SAE C
FLAT ROOT - SIDE FIT
J4998b-CLASS:1-PITCH:12/24
14 TEETH - 30° PRESS. ANGLE

Shaft code 1
(KEYED SAE C)

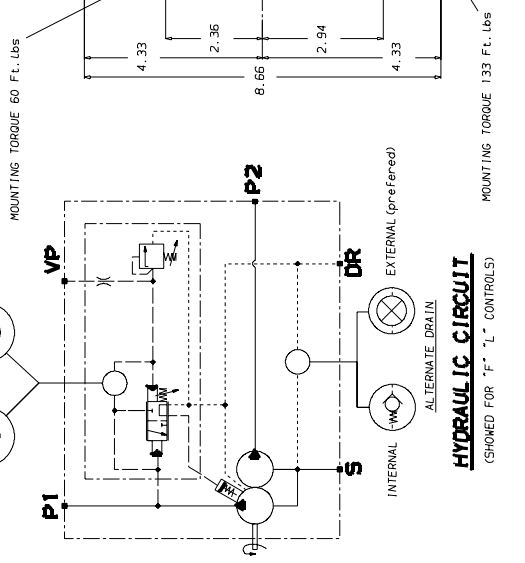
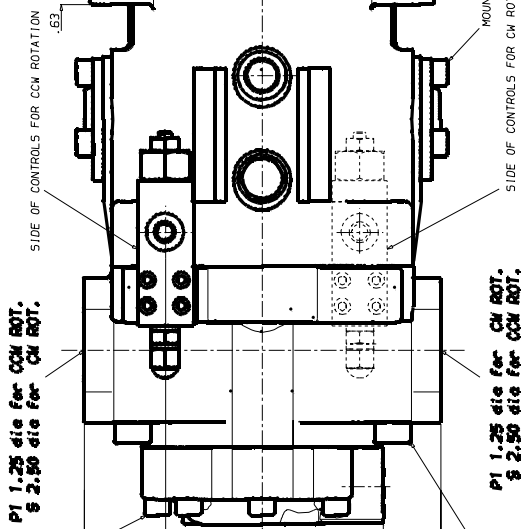

Port	Variable port			
	Code	A	B	Ø C
P2	0	2.06	1.03	1.00
P2	1	1.88	.88	.75

P1 1.25 dia for CCM ROT.
§ 2.50 dia for CM ROT.

P1 1.25 dia for CM ROT.
§ 2.50 dia for CCM ROT.

MOUNTING TORQUE 60 Ft. lbs

MOUNTING TORQUE 133 Ft. lbs

MOUNTING TORQUE 30.5 Ft. lbs

SIDE OF CONTROLS FOR CCM ROTATION

SIDE OF CONTROLS FOR CM ROTATION

HYDRAULIC CIRCUIT
(SHOWN FOR "F" "L" CONTROLS)

**INTERNAL LEAKAGE (TYPICAL)
"P2" CARTRIDGE**

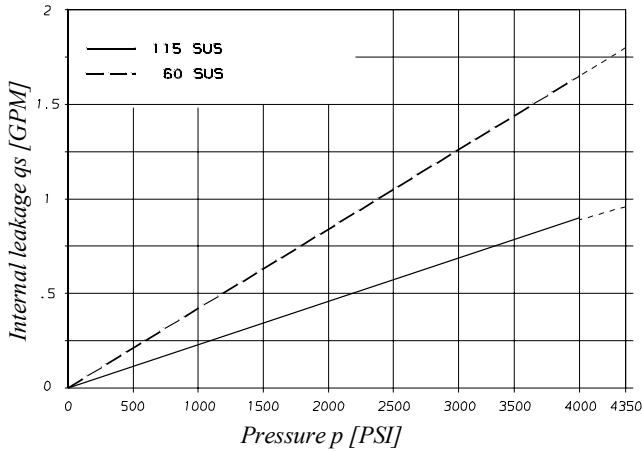

Do not operate pump more than 5 seconds at any speed or viscosity if internal leakage is higher than 50% of theoretical flow.

**NOISE LEVEL (TYPICAL)
T6H29B - B03**

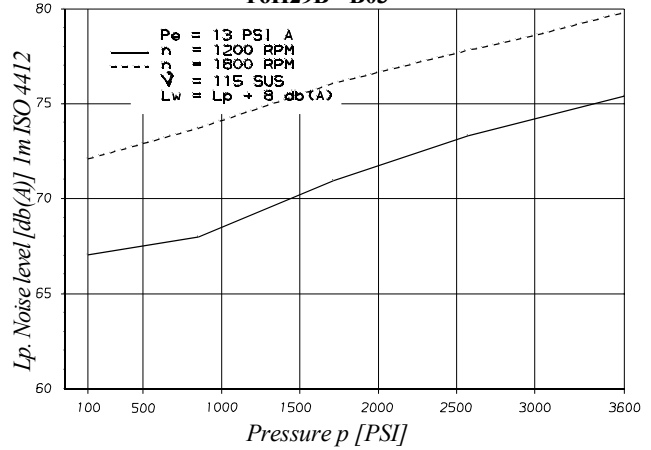

Noise level is given with each cartridge discharging at the pressure noted on the curve (P1 full flow).

**HYDROMECHANICAL POWER LOSS (TYPICAL)
"P2" CARTRIDGE**

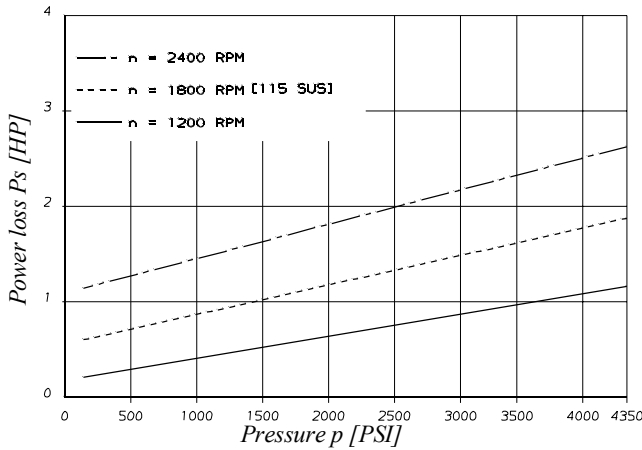

**OUTLET FLOW
"P1" CARTRIDGE**

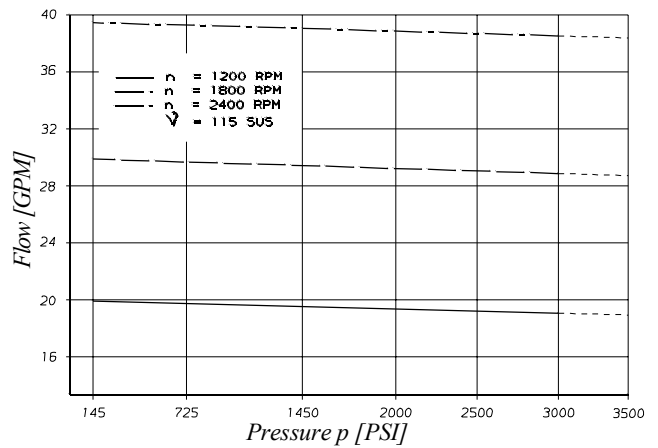

**OVERALL EFFICIENCY - "P1" CARTRIDGE
Full displacement**

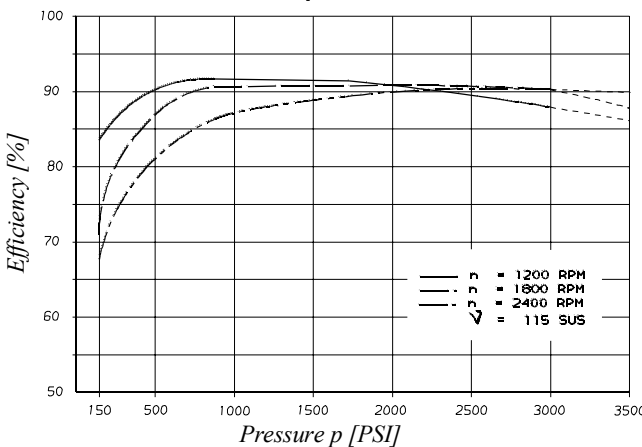

**INPUT HORSEPOWER - "P1" CARTRIDGE
Full displacement**

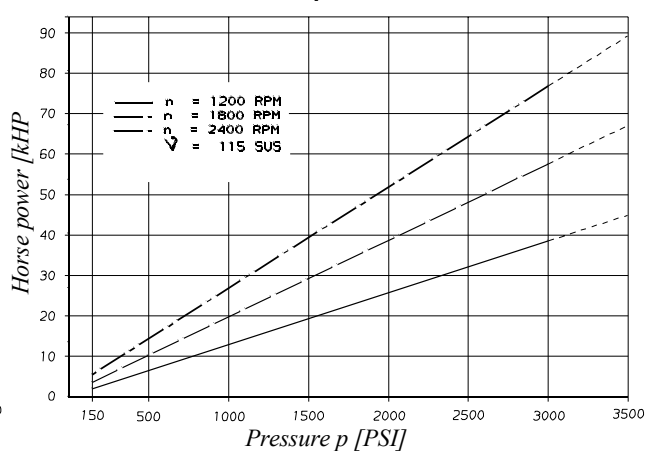

**INTERNAL LEAKAGE (TYPICAL)
"P2" CARTRIDGE**

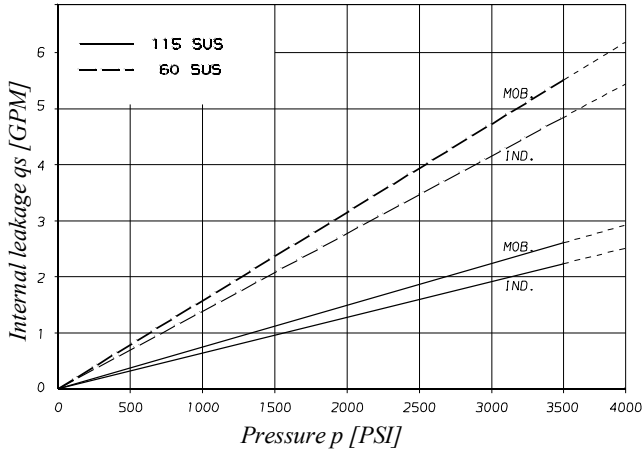

Do not operate pump more than 5 seconds at any speed or viscosity if internal leakage is higher than 50% of theoretical flow.

**NOISE LEVEL (TYPICAL)
T6H29C - B22**

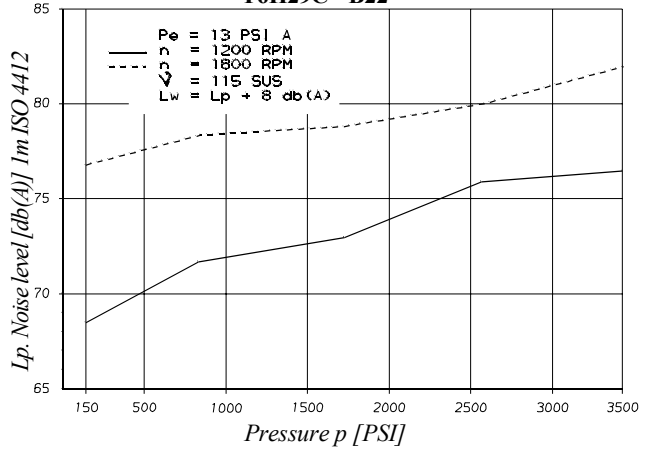

Noise level is given with each cartridge discharging at the pressure noted on the curve (P1 full flow).

**HYDROMECHANICAL POWER LOSS (TYPICAL)
"P2" CARTRIDGE**

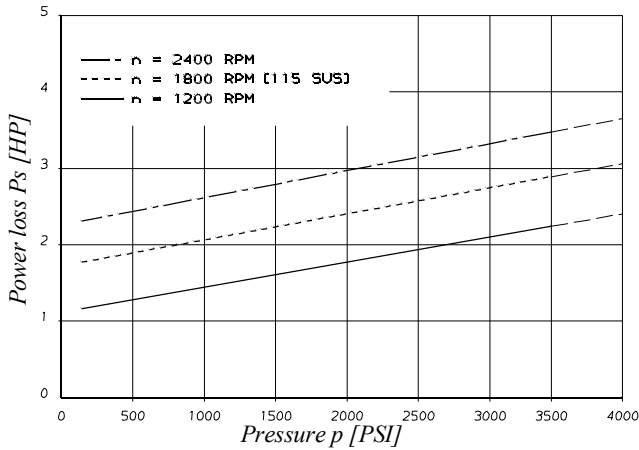

**OUTLET FLOW
"P1" CARTRIDGE**

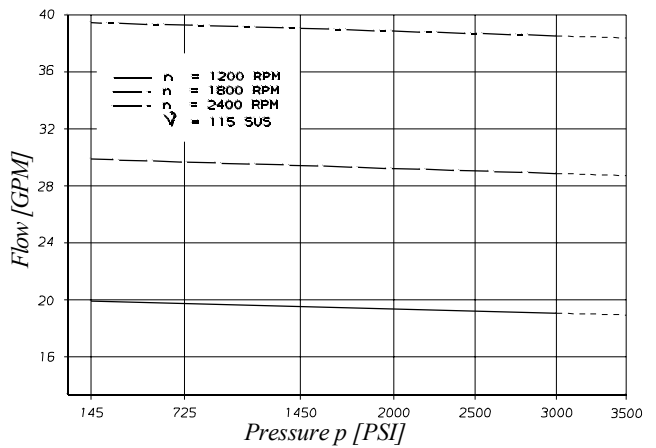

**OVERALL EFFICIENCY - "P1" CARTRIDGE
Full displacement**

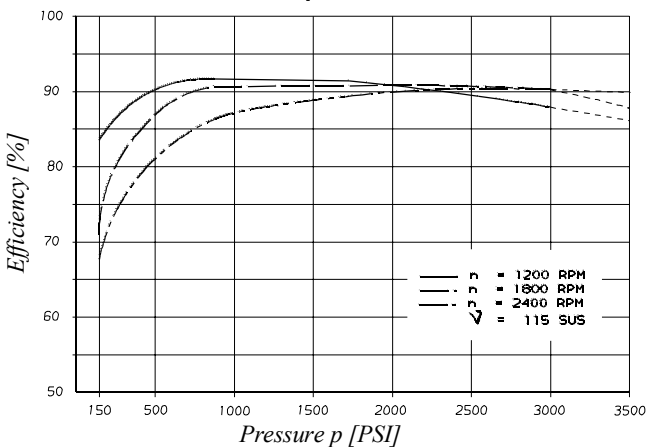

**INPUT HORSEPOWER - "P1" CARTRIDGE
Full displacement**

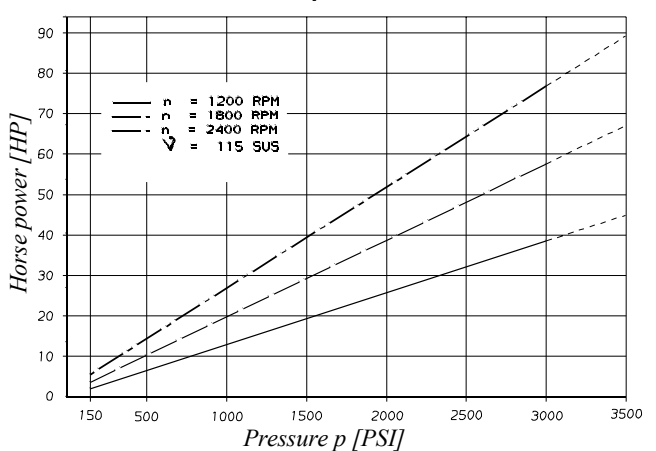

ORDERING CODE & OPERATING CHARACTERISTICS - T6H29D SERIES

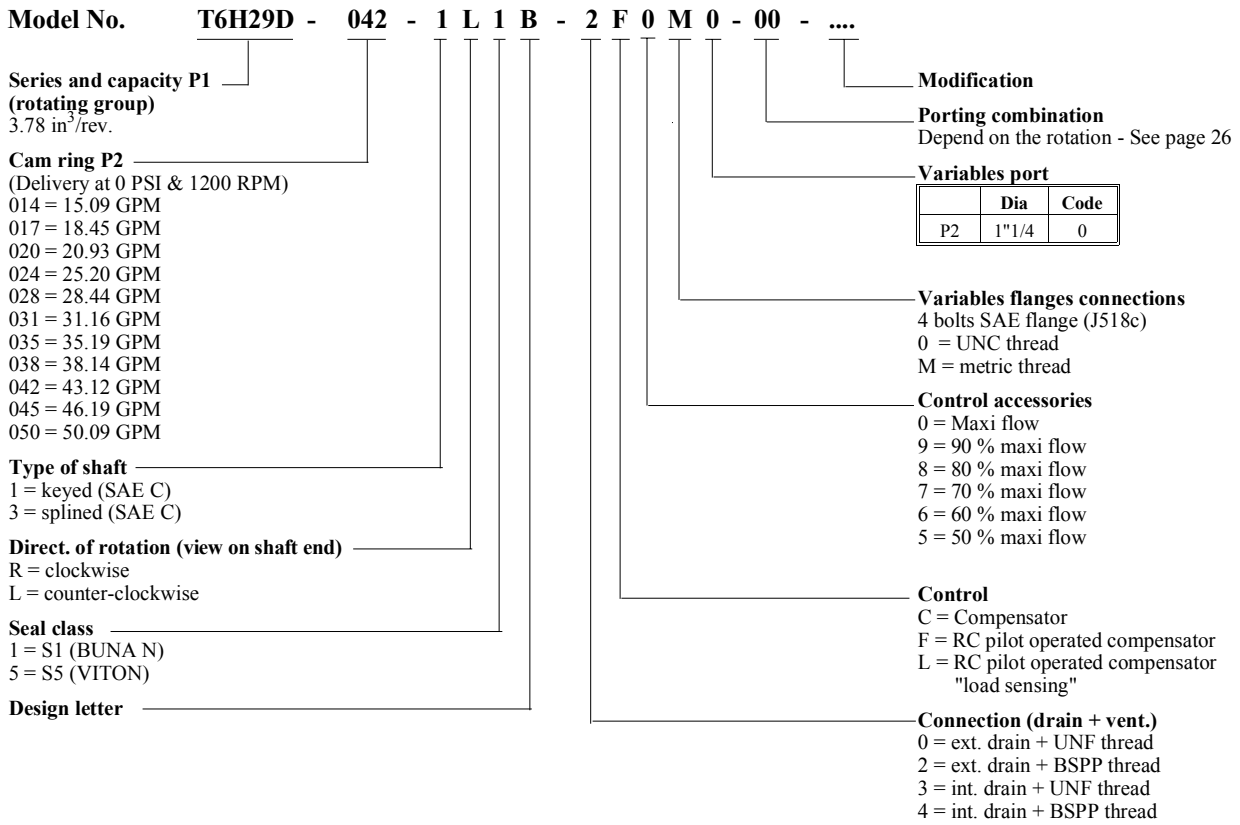

OPERATING CHARACTERISTICS - TYPICAL [115 SUS]

Pressure port	Series	Volumetric Displacement Vi	Flow qVe [GPM], n = 1800 RPM			Input power P [HP], n = 1800 RPM		
			p = 0 PSI	p = 2000 PSI	p = 3500 PSI	p = 100 PSI	p = 2000 PSI	p = 3500 PSI
P2	014	2.90 in ³ /rev	22.64	20.46	18.82	4.02	29.31	49.34
	017	3.55 in ³ /rev	27.68	25.50	23.86	4.31	35.20	59.64
	020	4.00 in ³ /rev	31.39	29.21	27.57	4.53	39.52	67.21
	024	4.80 in ³ /rev	37.81	35.63	33.99	4.91	47.02	80.32
	028	5.50 in ³ /rev	42.66	40.48	38.84	5.19	52.68	90.23
	031	6.00 in ³ /rev	46.75	44.57	42.93	5.43	57.45	98.58
	035	5.80 in ³ /rev	52.79	50.61	48.97	5.78	64.50	110.91
	038	7.30 in ³ /rev	57.21	55.03	53.39	6.04	69.66	119.94
	042 ¹⁾	8.30 in ³ /rev	64.68	62.50	60.86	6.47	78.37	135.19
	045 ¹⁾	8.90 in ³ /rev	69.29	67.11	65.47	6.74	83.75	144.61
050 ¹⁾	9.64 in ³ /rev	75.14	72.96	71.78 ²⁾	7.08	90.58	134.54 ²⁾	

¹⁾ 042 - 045 - 050 = 2200 RPM ²⁾ 050 = 3000 PSI max. int.

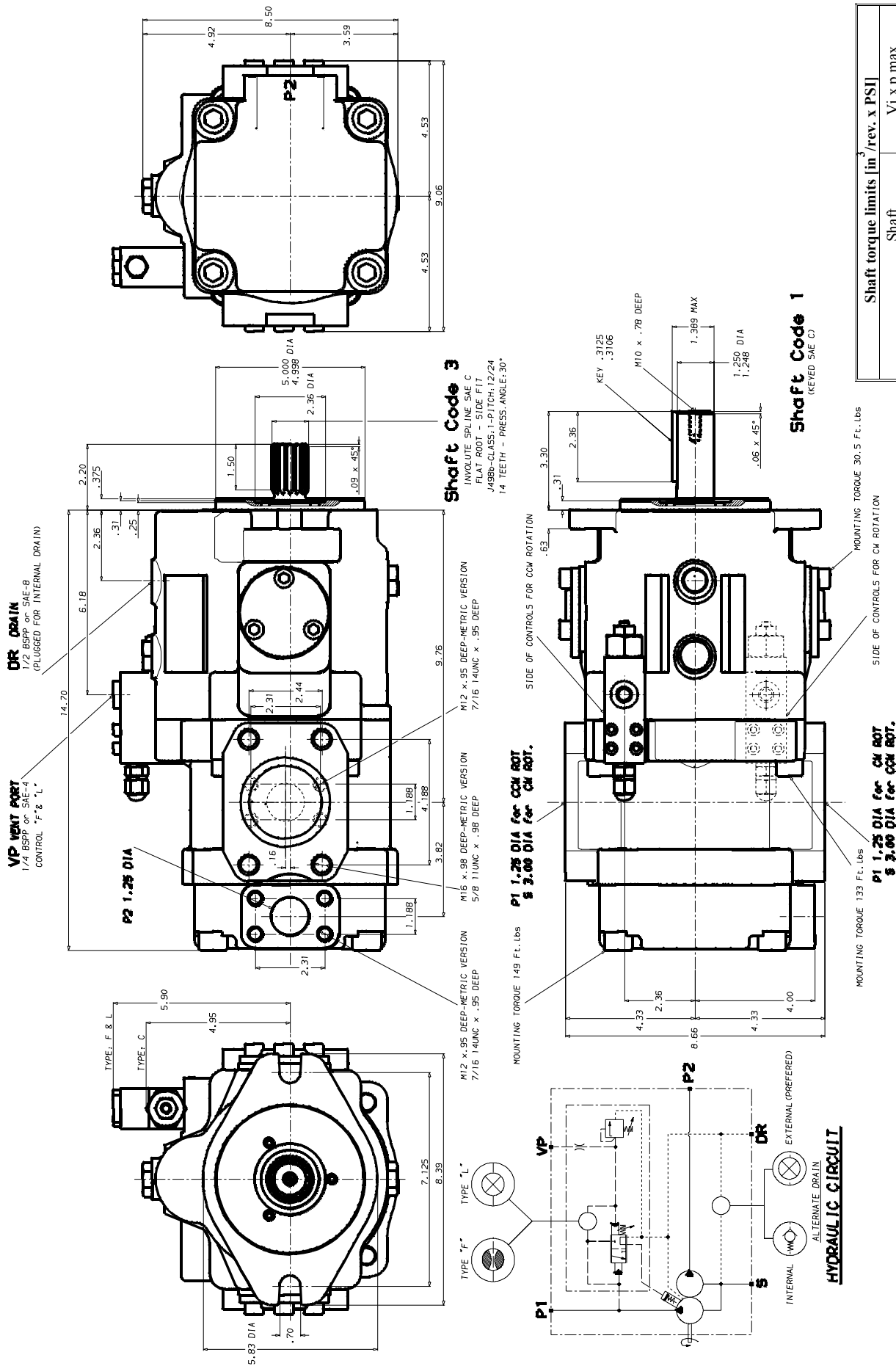

Shaft torque limits in ³ /rev. x PSI	V1 x p max.
Shaft	1
	38299

**INTERNAL LEAKAGE (TYPICAL)
"P2" CARTRIDGE**

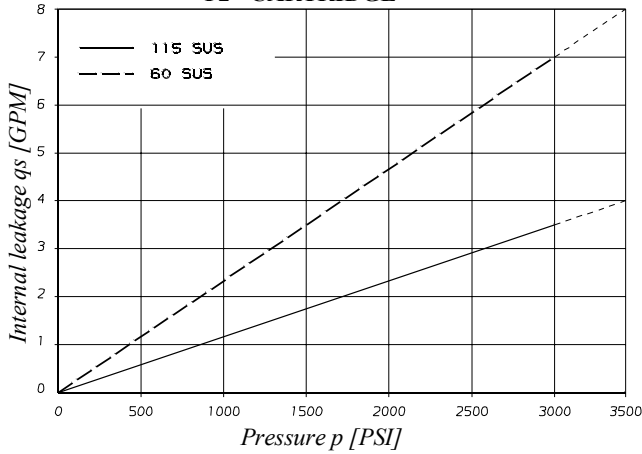

Do not operate pump more than 5 seconds at any speed or viscosity if internal leakage is higher than 50% of theoretical flow.

**NOISE LEVEL (TYPICAL)
T6H29D - 038**

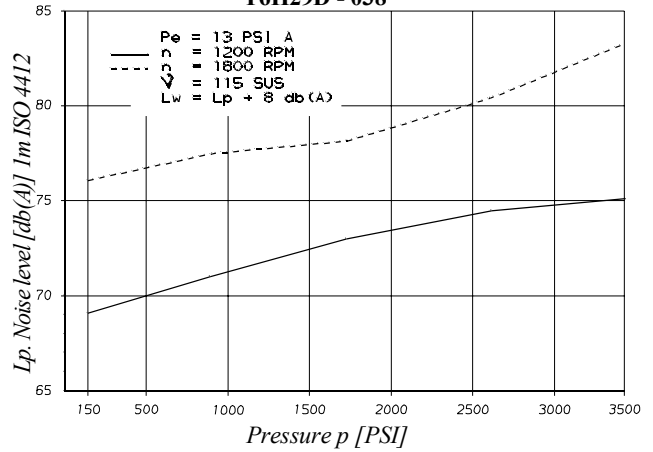

Noise level is given with each cartridge discharging at the pressure noted on the curve (P1 full flow).

**HYDROMECHANICAL POWER LOSS (TYPICAL)
"P2" CARTRIDGE**

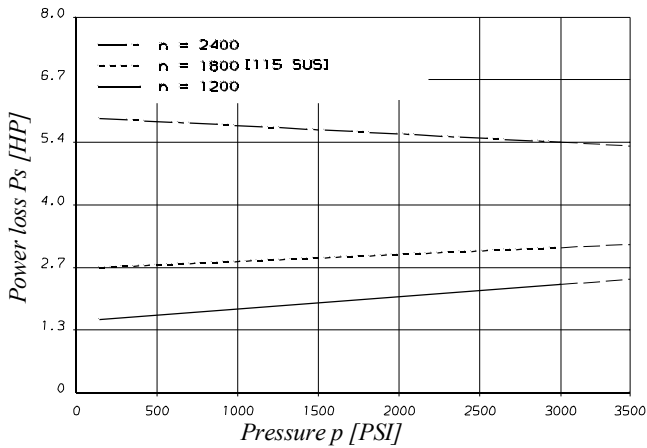

**OUTLET FLOW
"P1" CARTRIDGE**

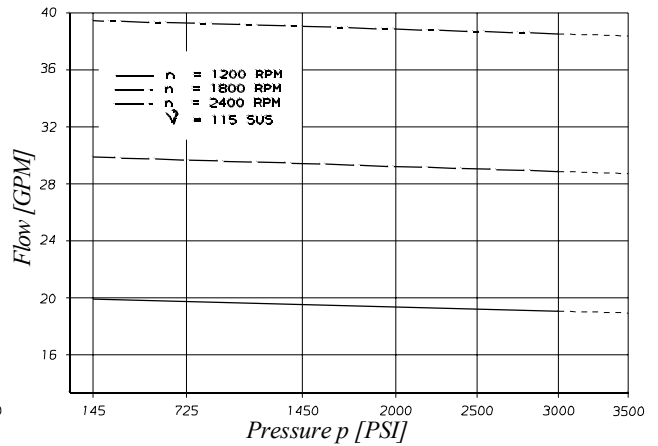

**OVERALL EFFICIENCY - "P1" CARTRIDGE
Full displacement**

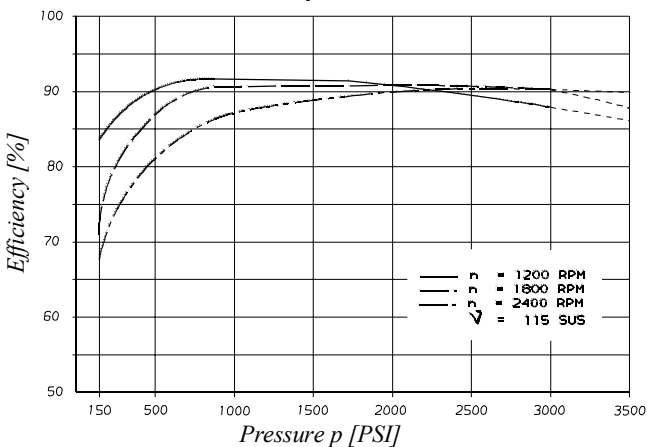

**INPUT HORSEPOWER - "P1" CARTRIDGE
Full displacement**

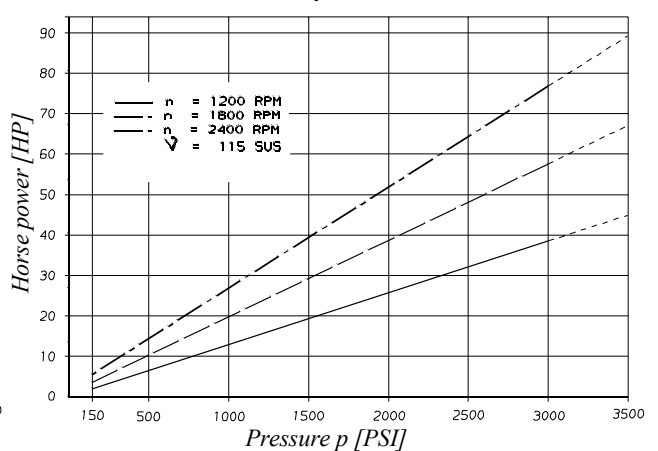

ORDERING CODE & OPERATING CHARACTERISTICS - T6H29DB SERIES

Model No. **T6H29DB - 042 - B10 - 1 L 1 B - 2 F 0 M 0 - 00 - ...**

Series and capacity P1
(rotating group)
3.78 in³/rev

Cam ring P2
(Delivery at 0 PSI & 1200 RPM)
014 = 15.09 GPM
017 = 18.45 GPM
020 = 20.93 GPM
024 = 25.20 GPM
028 = 28.44 GPM
031 = 31.16 GPM
035 = 35.19 GPM
038 = 38.14 GPM
042 = 43.12 GPM
045 = 46.19 GPM
050 = 50.09 GPM

Cam ring P3
(Delivery at 0 PSI & 1200 RPM)
B02 = 1.84 GPM
B03 = 3.11 GPM
B04 = 4.06 GPM
B05 = 50.4 GPM
B06 = 6.28 GPM
B07 = 7.13 GPM
B08 = 7.89 GPM
B10 = 10.08 GPM
B12 = 13.00 GPM
B15 = 15.85 GPM

Type of shaft
1 = keyed (SAE C)
3 = splined (SAE C)

Direct. of rotation (view on shaft end)
R = clockwise
L = counter-clockwise

Seal class
1 = S1 (BUNA N)
5 = S5 (VITON)

Modification

Porting combination
Depend on the rotation - See page 27

Variable port

	Dia	Code
P3	1"	0
P3	3/4"	1

Variables flanges connections
4 bolts SAE flange (J518c)
0 = UNC thread
M = metric thread

Control accessories

0 = Maxi flow
9 = 90 % maxi flow
8 = 80 % maxi flow
7 = 70 % maxi flow
6 = 60 % maxi flow
5 = 50 % maxi flow

Control

C = Compensator
F = RC pilot operated compensator
L = RC pilot operated compensator
"load sensing"

Connection (drain + vent.)

0 = ext. drain + UNF thread
2 = ext. drain + BSPP thread
3 = int. drain + UNF thread
4 = int. drain + BSPP thread

Design letter

OPERATING CHARACTERISTICS - TYPICAL [115 SUS]

Pressure port	Series	Volumetric Displacement Vi	Flow qVc [GPM], n = 1800 RPM			Input power P [HP], n = 1800 RPM		
			p = 0 PSI	p = 2000 PSI	p = 3500 PSI	p = 100 PSI	p = 2000 PSI	p = 3500 PSI
P2	014	2.90 in ³ /rev	22.64	20.46	18.82	4.02	29.31	49.34
	017	3.55 in ³ /rev	27.68	25.50	23.86	4.31	35.20	59.64
	020	4.00 in ³ /rev	31.39	29.21	27.57	4.53	39.52	67.21
	024	4.80 in ³ /rev	37.81	35.63	33.99	4.91	47.02	80.32
	028	5.50 in ³ /rev	42.66	40.48	38.84	5.19	52.68	90.23
	031	6.00 in ³ /rev	46.75	44.57	42.93	5.43	57.45	98.58
	035	6.80 in ³ /rev	52.79	50.61	48.97	5.78	64.50	110.91
	038	7.30 in ³ /rev	57.21	55.03	53.39	6.04	69.66	119.94
	042 ¹⁾	8.30 in ³ /rev	64.68	62.50	60.86	6.47	78.37	135.19
	045 ¹⁾	8.90 in ³ /rev	69.29	67.11	65.47	6.74	83.75	144.61
050 ¹⁾	9.64 in ³ /rev	75.14	72.96	71.78 ²⁾	7.08	90.58	134.54 ²⁾	
			p = 0 PSI	p = 2000 PSI	p = 4350 PSI	p = 100 PSI	p = 2000 PSI	p = 4350 PSI
P3	B02	.35 in ³ /rev	2.76	2.33	1.80	0.74	4.02	8.10
	B03	.60 in ³ /rev	4.66	4.23	3.70	0.85	6.24	12.93
	B04	.78 in ³ /rev	6.09	5.66	5.13	0.94	7.90	16.55
	B05	.97 in ³ /rev	7.56	7.13	6.60	1.02	9.62	20.29
	B06	1.21 in ³ /rev	9.42	8.99	8.46	1.13	11.79	25.00
	B07	1.37 in ³ /rev	10.70	10.27	9.74	1.20	13.29	28.26
	B08	1.52 in ³ /rev	11.84	11.41	10.88	1.27	14.62	31.15
	B10	1.94 in ³ /rev	15.12	14.69	14.16	1.46	18.45	39.48
	B12	2.50 in ³ /rev	19.50	19.07	18.54	1.72	23.55	50.58
	B15	3.05 in ³ /rev	23.78	23.35	22.88 ³⁾	1.97	28.55	57.35 ³⁾

¹⁾ 042 - 045 - 050 = 2200 RPM ²⁾ 050 = 3000 PSI max. int. ³⁾ B15 = 4060 PSI max. int

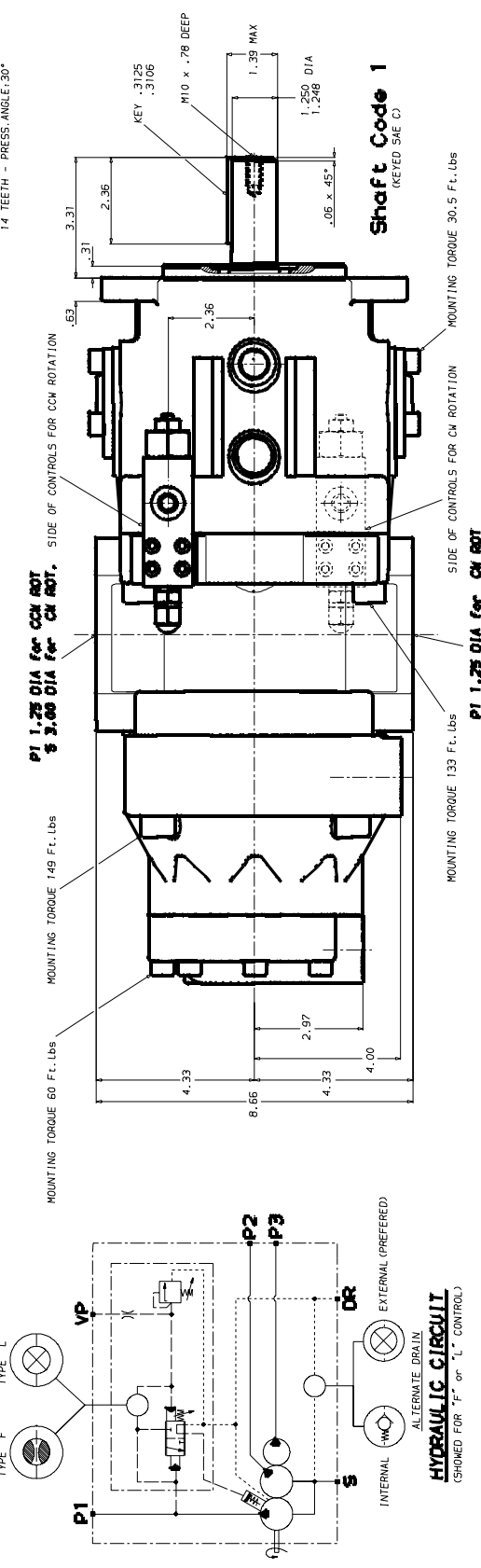
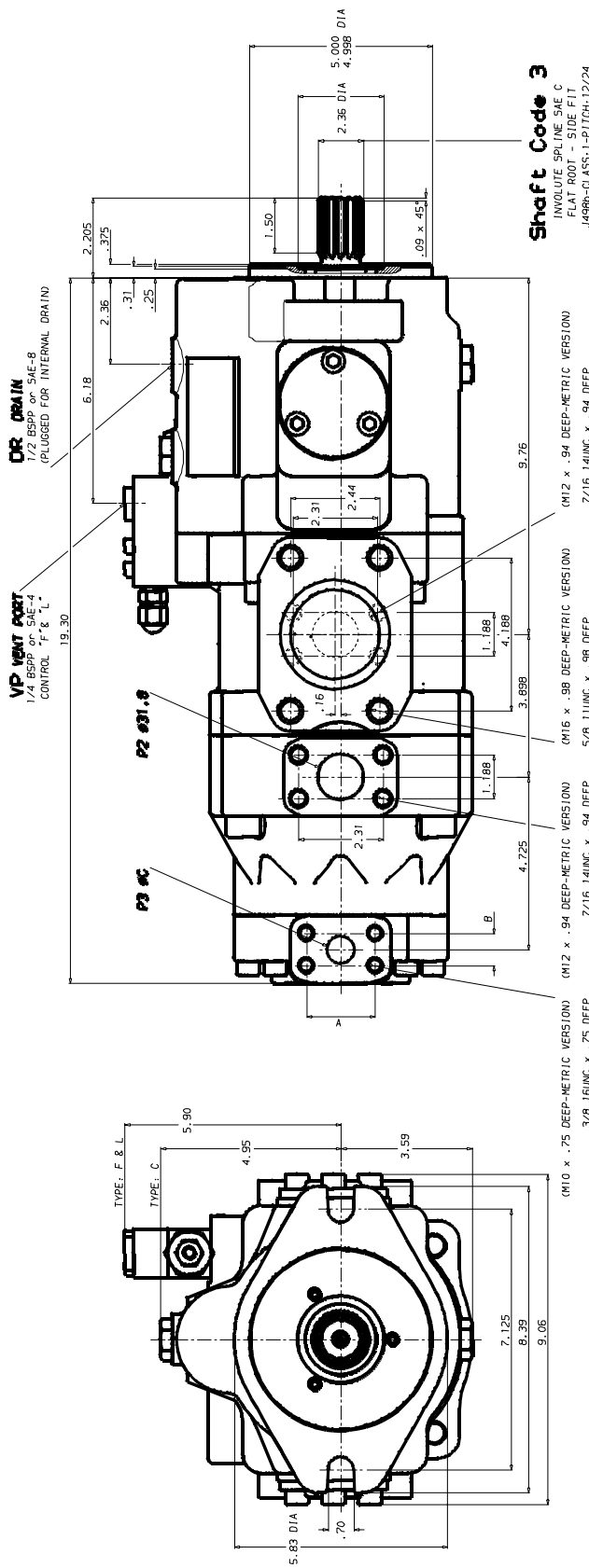

Variable port

Port	Code	A	B	Ø C
P2	0	2.06	1.03	1.00
P2	1	1.88	.88	.75

Shaft torque limits ³ /rev. x PSI

Shaft	V i x p max. (P1+P2+P3)	46484
1		

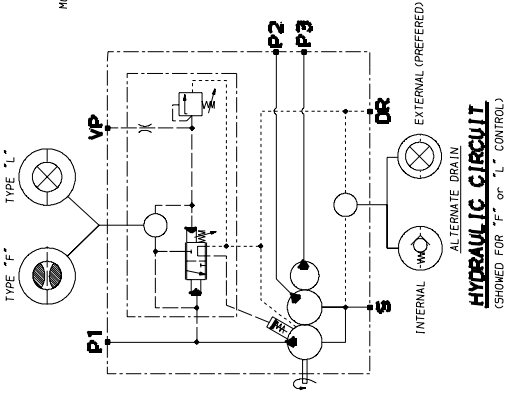

**INTERNAL LEAKAGE (TYPICAL)
"P2" - "P3" CARTRIDGES**

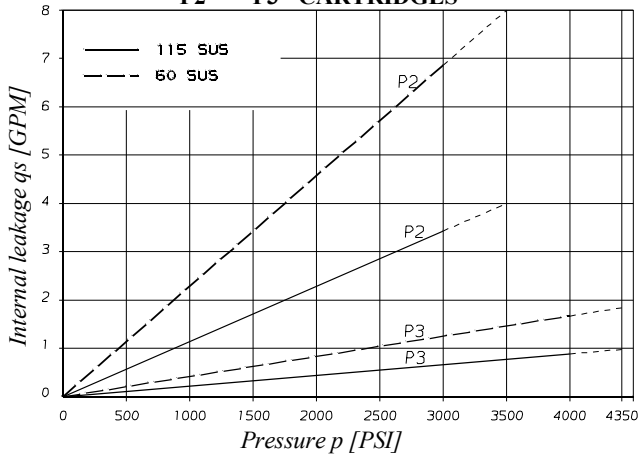

Do not operate pump more than 5 seconds at any speed or viscosity if internal leakage is higher than 50% of theoretical flow.

**NOISE LEVEL (TYPICAL)
T6H29DB - 028 - B10**

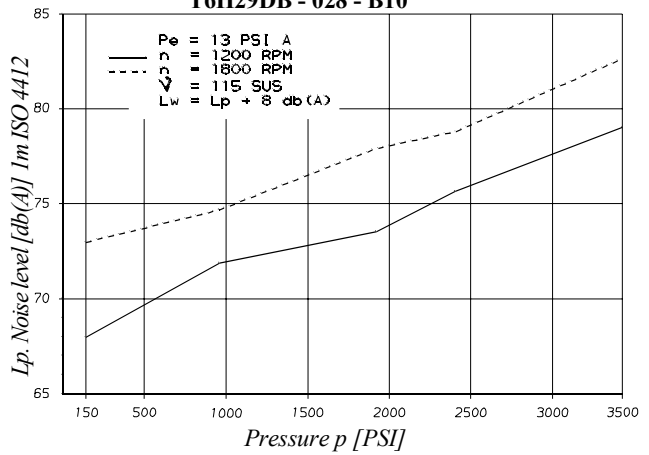

Noise level is given with each cartridge discharging at the pressure noted on the curve (P1 full flow).

**HYDROMECHANICAL POWER LOSS (TYPICAL)
"P2" - "P3" CARTRIDGES**

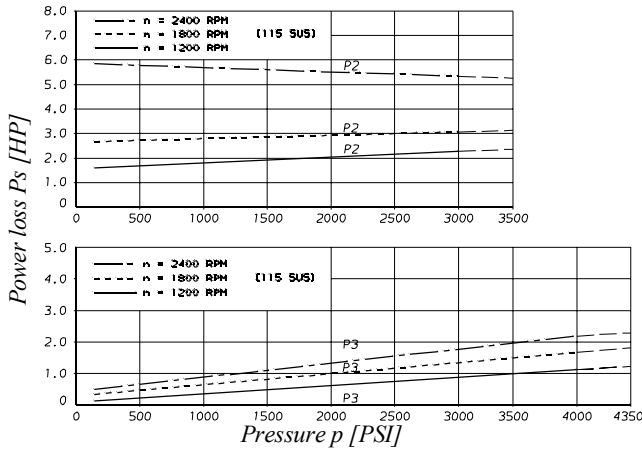

**OUTLET FLOW
"P1" CARTRIDGE**

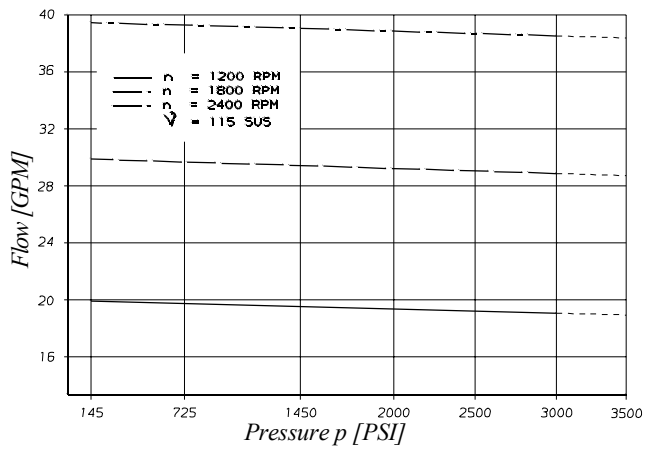

**OVERALL EFFICIENCY - "P1" CARTRIDGE
Full displacement**

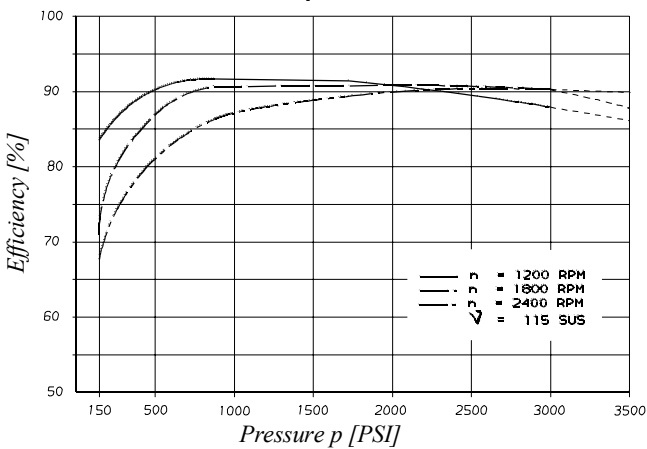

**INPUT HORSEPOWER - "P1" CARTRIDGE
Full displacement**

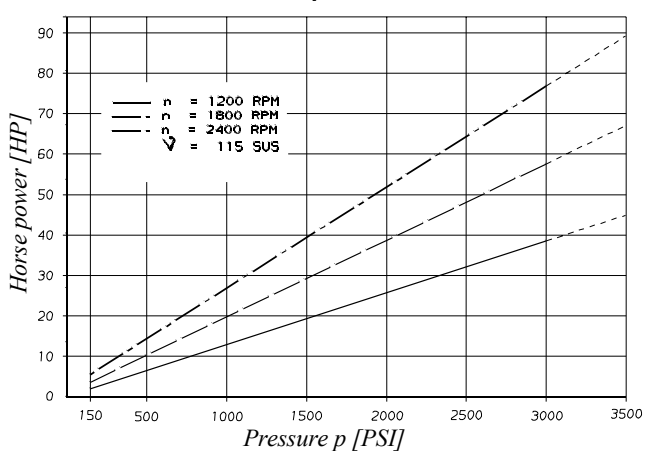

DEPEND ON THE ROTATION

T6H20B - T6H20C
T6H29B - T6H29C

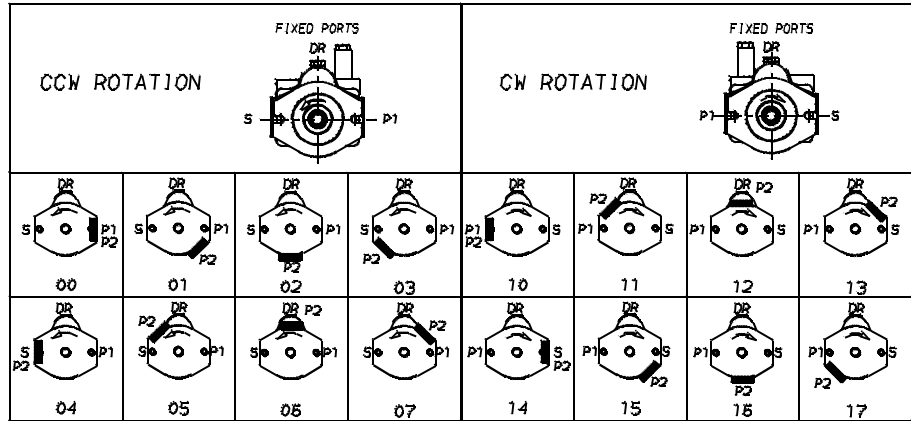

T6H29D

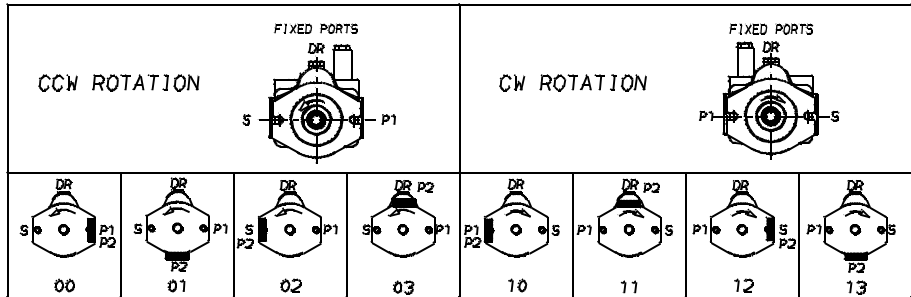

DEPEND ON THE ROTATION

T6H29DB

CCW ROTATION				CW ROTATION			
FIXED PORTS				FIXED PORTS			
00	08	16	24	40	48	56	64
01	09	17	25	41	49	57	65
02	10	18	26	42	50	58	66
03	11	19	27	43	51	59	67
04	12	20	28	44	52	60	68
05	13	21	29	45	53	61	69
06	14	22	30	46	54	62	70
07	15	23	31	47	55	63	71