



## DENISON HYDRAULICS

### T6EDC - T6EDCM - T6EDCS - T6EDCR

vane-type triple pump / Flügelzellen-Dreifachpumpe

pompe triple à palettes / pompa tripla a palette

tipo bomba de paletas triple

**service information**

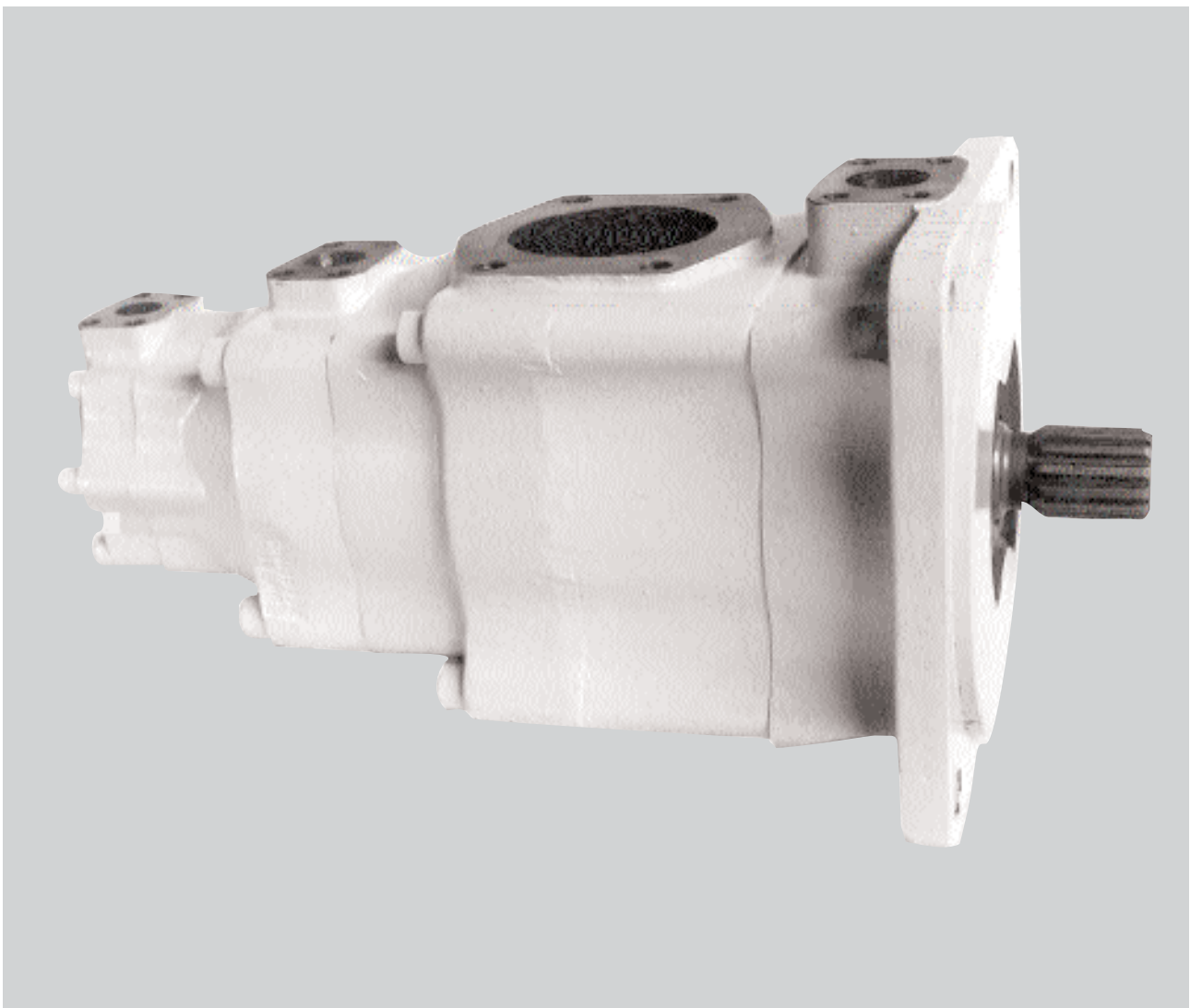

Publ. S1 - ML0509 - C

03 / 2003 / FB

Replaces : S1 - ML0509 - B

L25 - 10509 - 3

**DENISON** Hydraulics

Recommended repair kits and assy's are bold printed  
 Empfohlene Austausch - Baugruppen sind fett gedruckt  
 Les pochettes de rechange recommandées sont imprimées en caractères gras  
 I kit di ricambio consigliati sono indicati in grassetto  
 Los juegos de reparacion recomendados y los conjuntos, estan en negrita

	Item - Pos. - Réf. - Pos.		
	50	52	56
Mounting torque			
Anziehdrehmoment	300 Nm	190 Nm	80 Nm
Couple de serrage	221 ft.lbs	140 ft.lbs	60 ft.lbs
Coppia di serraggio			
Par de apriete			

# T6EDC

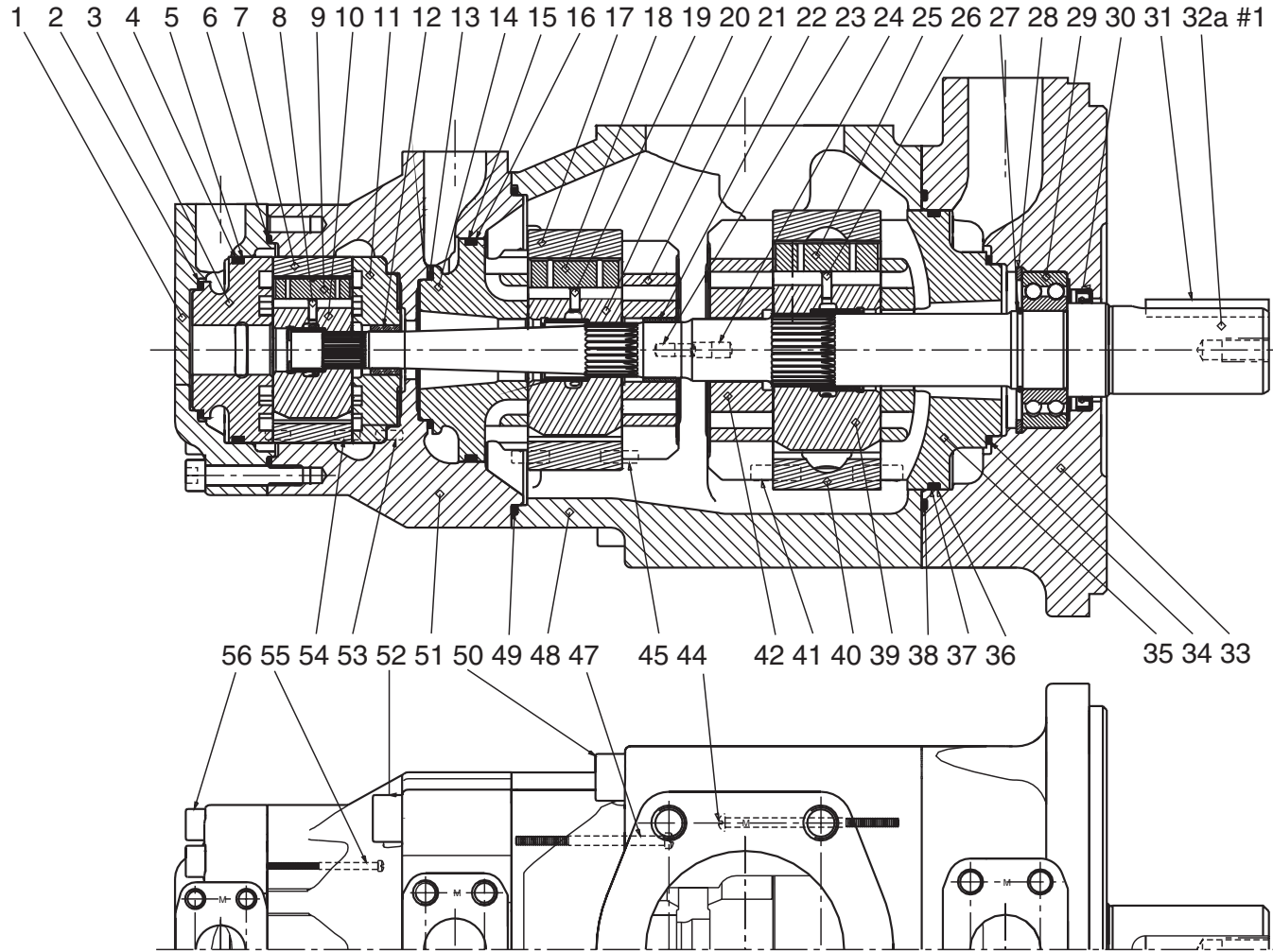

Recommended repair kits and assy's are bold printed  
 Empfohlene Austausch - Baugruppen sind fett gedruckt  
 Les pochettes de rechange recommandées sont imprimées en caractères gras  
 I kit di ricambio consigliati sono indicati in grassetto  
 Los juegos de reparacion recomendados y los conjuntos, estan en negrita

	Item - Pos. - Réf. - Pos.		
	50	52	56
Mounting torque			
Anziehdrehmoment	300 Nm	190 Nm	80 Nm
Couple de serrage	221 ft.lbs	140 ft.lbs	60 ft.lbs
Coppia di serraggio			
Par de apriete			

# T6EDCM

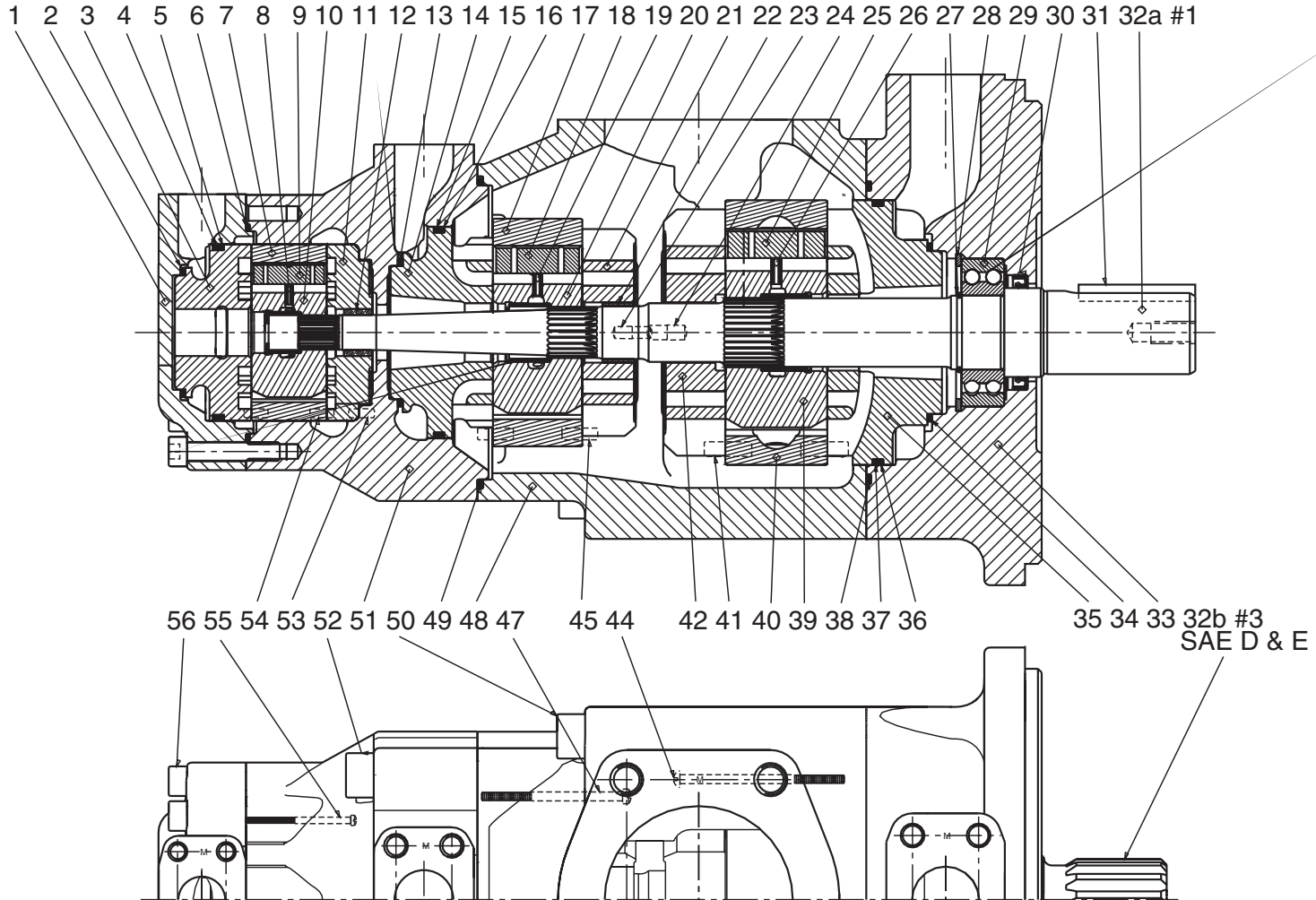

Recommended repair kits and assy's are bolt printed  
 Empfohlene Austausch - Baugruppen sind fett gedruckt  
 Les pochettes de rechange recommandées sont imprimées en caractères gras  
 I kit di ricambio consigliati sono indicati in grassetto  
 Los juegos de reparacion recomendados y los conjuntos, estan en negrita

	Item - Pos. - Réf. - Pos.		
	50	52	56
Mounting torque			
Anziehdrehmoment	300 Nm	190 Nm	80 Nm
Couple de serrage	221 ft.lbs	140 ft.lbs	60 ft.lbs
Coppia di serraggio			
Par de apriete			

# T6EDCS

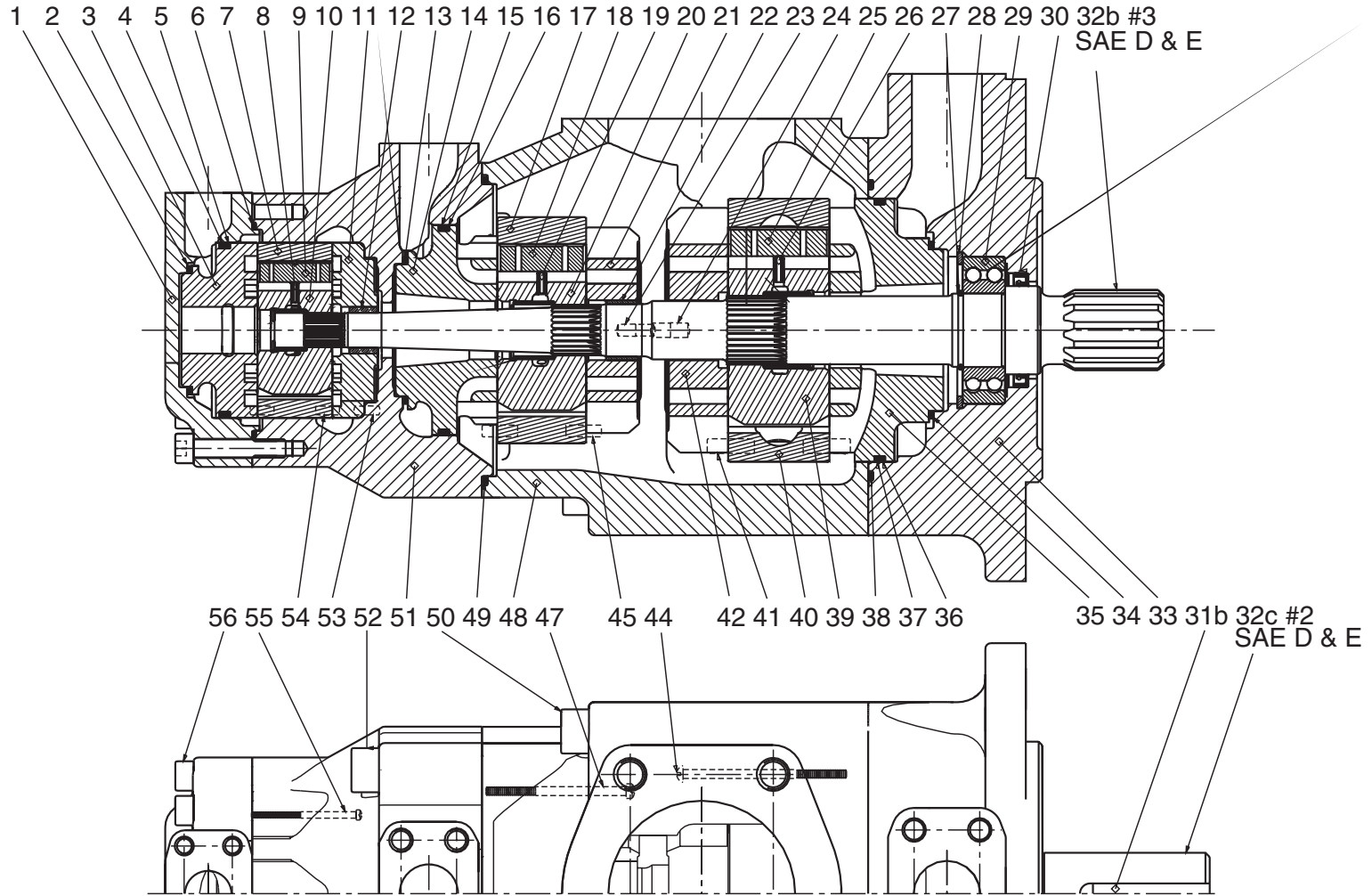

Recommended repair kits and assy's are bold printed  
 Empfohlene Austausch - Baugruppen sind fett gedruckt  
 Les pochettes de rechange recommandées sont imprimées en caractères gras  
 I kit di ricambio consigliati sono indicati in grassetto  
 Los juegos de reparacion recomendados y los conjuntos, estan en negrita

	Item - Pos. - Réf. - Pos.		
	50	52	56
Mounting torque			
Anziehdrehmoment	300 Nm	190 Nm	80 Nm
Couple de serrage	221 ft.lbs	140 ft.lbs	60 ft.lbs
Coppia di serraggio			
Par de apriete			

# T6EDCR

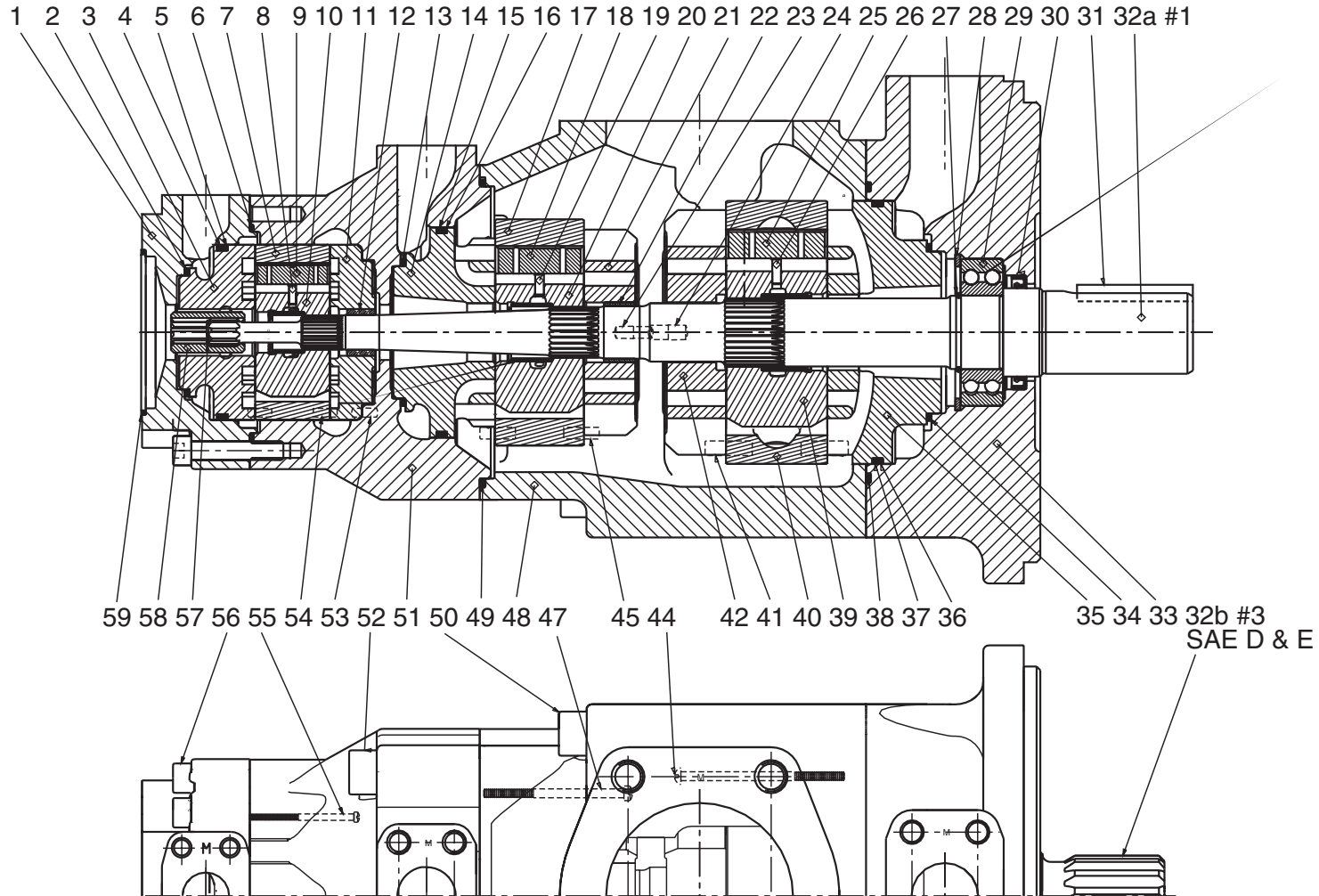

Item Pos. Réf. Pos. Pos.	Description Descrizione	Benennung Descripción	Description		Part N° Teil Nr. Code N° Cod. N° Referencia T6EDC	Part N° Teil Nr. Code N° Cod. N° Referencia T6EDCM	Part N° Teil Nr. Code N° Cod. N° Referencia T6EDCS	Part N° Teil Nr. Code N° Cod. N° Referencia T6EDCR	Qty Stück Qté Q.ta Cant.	
1	End cap (P3 = 3/4") <i>Coperchio (P3 = 3/4")</i>	Deckel (P3 = 3/4") <i>Tapa (P3 = 3/4")</i>	Chapeau (P3 = 3/4")		034.66765	034.66765	034.66523	034.66757	1	
	End cap (P3 = 1") <i>Coperchio (P3 = 1")</i>	Deckel (P3 = 1") <i>Tapa (P3 = 1")</i>	Chapeau (P3 = 1")		034.71327	034.71327	034.48579	034.66793	1	
2	Sq. section seal <i>Guarnizione</i>	Dichtring <i>Junta seccion cuadrada</i>	Joint section carrée	CDS	691.10229				1	
3	Port plate-pressure C.C.W. <i>Piatto distributore anter. antioraria</i>	Steuerplatte Linkslauf <i>Plato distribuidor-presión giro I</i>	Plaque pression rotation gauche	CS	034.59772			034.59772	1	
	Port plate-pressure C.W. <i>Piatto distributore anter. oraria</i>	Steuerplatte Rechtslauf <i>Plato distribuidor-presión giro D</i>	Plaque pression rotation droite	CS	034.59773			034.59773	1	
	Port plate-pressure <i>Piatto distributore anter.</i>	Steuerplatte <i>Plato distribuidor-presión</i>	Plaque pression	CS		034.66453	034.66453		1	
4	Sq. section seal <i>Guarnizione</i>	Dichtring <i>Junta seccion cuadrada</i>	Joint section carrée	CDS	691.10238				1	
5	Back-up ring <i>Anello anti-estrusione</i>	Stützring <i>Anillo</i>	Bague anti-extrusion	CDS	618.00010.3				1	
6	Sq. section seal <i>Guarnizione</i>	Dichtring <i>Junta seccion cuadrada</i>	Joint section carrée	CDS	671.10156				1	
7	Cam ring 003 <i>Anello camma 003</i>	Hubring 003 <i>Aro volumetrico 003</i>	Came 003	CS	034.59050				1	
	Cam ring 005 <i>Anello camma 005</i>	Hubring 005 <i>Aro volumetrico 005</i>	Came 005	CS	034.59051				1	
	Cam ring 006 <i>Anello camma 006</i>	Hubring 006 <i>Aro volumetrico 006</i>	Came 006	CS	034.59052				1	
	Cam ring 008 <i>Anello camma 008</i>	Hubring 008 <i>Aro volumetrico 008</i>	Came 008	CS	034.59053				1	
	Cam ring 010 <i>Anello camma 010</i>	Hubring 010 <i>Aro volumetrico 010</i>	Came 010	CS	034.59054				1	
	Cam ring 012 <i>Anello camma 012</i>	Hubring 012 <i>Aro volumetrico 012</i>	Came 012	CS	034.66595				1	
	Cam ring 014 <i>Anello camma 014</i>	Hubring 014 <i>Aro volumetrico 014</i>	Came 014	CS	034.59206				1	
	Cam ring 017 <i>Anello camma 017</i>	Hubring 017 <i>Aro volumetrico 017</i>	Came 017	CS	034.59207				1	
	Cam ring 020 <i>Anello camma 020</i>	Hubring 020 <i>Aro volumetrico 020</i>	Came 020	CS	034.66607				1	
	Cam ring 022 <i>Anello camma 022</i>	Hubring 022 <i>Aro volumetrico 022</i>	Came 022	CS	034.59208				1	
	Cam ring 025 <i>Anello camma 025</i>	Hubring 025 <i>Aro volumetrico 025</i>	Came 025	CS	034.59209				1	
	Cam ring 028 <i>Anello camma 028</i>	Hubring 028 <i>Aro volumetrico 028</i>	Came 028	CS	034.59245				1	
	Cam ring 031 <i>Anello camma 031</i>	Hubring 031 <i>Aro volumetrico 031</i>	Came 031	CS	034.66843				1	
	8	Pin-vane holdout <i>Pistoncino di sostentamento</i>	Stössel <i>Espiga empuje paleta</i>	Poussoir de palette	CS	034.59098	034.24982	034.24982	034.59098	10
	9	Vane <i>Paletta</i>	Flügel <i>Paleta</i>	Palette	CS	034.59099	034.66716	034.66716	034.59099	10
10	Rotor-insert ass'y <i>Insieme rotore</i>	Rotor <i>Conjunto rotor</i>	Rotor et douille ass.	CS	S24.10116	S24.30049	S24.30049	S24.10116	1	

Item Pos. Réf. Pos.	Description Descrizione	Benennung Descripción	Description		Part N° Teil Nr. Code N° Cod. N° Referencia T6EDC	Part N° Teil Nr. Code N° Cod. N° Referencia T6EDCM	Part N° Teil Nr. Code N° Cod. N° Referencia T6EDCS	Part N° Teil Nr. Code N° Cod. N° Referencia T6EDCR	Qty Stück Qté Q.tà Cant.	
11	Port plate-rear C.C.W. <i>Piatto distributore post. antioraria</i>	Steuerplatte Linkslauf <i>Plato distribuidor trasero giro I</i>	Plaque arrière rotation gauche	CLS	034.59776			034.59776	1	
	Port plate-rear C.W. <i>Piatto distributore post. oraria</i>	Steuerplatte Rechtslauf <i>Plato distribuidor trasero giro D</i>	Plaque arrière rotation droite	CLS	034.59777			034.59777	1	
	Port plate-rear <i>Piatto distributore post.</i>	Steuerplatte <i>Plato distribuidor trasero</i>	Plaque arrière	CL		034.59118	034.59118		1	
12	Bush <i>Bussola</i>	Buchse <i>Cojinete de fricción</i>	Bague	CL MS	034.59412			1		
13	Sq. section seal <i>Guarnizione</i>	Dichtring <i>Junta seccion cuadrada</i>	Joint section carrée	BDR	691.10232			1		
14	Port plate-pressure C.C.W. <i>Piatto distributore anter. antioraria</i>	Steuerplatte Linkslauf <i>Plato distribuidor-presión giro I</i>	Plaque pression rotation gauche	BR	034.67111			034.67111	1	
	Port plate-pressure C.W. <i>Piatto distributore anter. oraria</i>	Steuerplatte Rechtslauf <i>Plato distribuidor-presión giro D</i>	Plaque pression rotation droite	BR	034.67113			034.67113	1	
	Port plate-pressure <i>Piatto distributore anter.</i>	Steuerplatte <i>Plato distribuidor-presión</i>	Plaque pression	B		034.59057	034.59057		1	
15	Sq. section seal <i>Guarnizione</i>	Dichtring <i>Junta seccion cuadrada</i>	Joint section carrée	BDR	691.10244			1		
16	Back-up ring <i>Anello anti-estrusione</i>	Stützring <i>Anillo</i>	Bague anti-extrusion	BR	618.00011.3			1		
17	Cam ring 014 <i>Anello camma 014</i>	Hubring 014 <i>Aro volumetrico 014</i>	Came 014	BR	034.66708			1		
	Cam ring 017 <i>Anello camma 017</i>	Hubring 017 <i>Aro volumetrico 017</i>	Came 017	BR	034.67028			1		
	Cam ring 020 <i>Anello camma 020</i>	Hubring 020 <i>Aro volumetrico 020</i>	Came 020	BR	034.66596			1		
	Cam ring 024 <i>Anello camma 024</i>	Hubring 024 <i>Aro volumetrico 024</i>	Came 024	BR	034.59294			1		
	Cam ring 028 <i>Anello camma 028</i>	Hubring 028 <i>Aro volumetrico 028</i>	Came 028	BR	034.59133			1		
	Cam ring 031 <i>Anello camma 031</i>	Hubring 031 <i>Aro volumetrico 031</i>	Came 031	BR	034.59135			1		
	Cam ring 035 <i>Anello camma 035</i>	Hubring 035 <i>Aro volumetrico 035</i>	Came 035	BR	034.59137			1		
	Cam ring 038 <i>Anello camma 038</i>	Hubring 038 <i>Aro volumetrico 038</i>	Came 038	BR	034.59139			1		
	Cam ring 042 <i>Anello camma 042</i>	Hubring 042 <i>Aro volumetrico 042</i>	Came 042	BR	034.59132			1		
	Cam ring 045 <i>Anello camma 045</i>	Hubring 045 <i>Aro volumetrico 045</i>	Came 045	BR	034.59131			1		
	Cam ring 050 <i>Anello camma 050</i>	Hubring 050 <i>Aro volumetrico 050</i>	Came 050	BR	034.66737			1		
	18	Vane <i>Paletta</i>	Flügel <i>Paleta</i>	Palette	BR	034.53588			10	
	19	Pin-vane holdout <i>Pistoncino di sostentamento</i>	Stößel <i>Espiga empuje paleta</i>	Poussoir de palette	BR	034.59130	034.24984	034.24984	034.59130	10
	20	Rotor-insert ass'y <i>Insieme rotore</i>	Rotor <i>Conjunto rotor</i>	Rotor et douille ass.	BR	S24.10121	S24.30018	S24.30018	S24.10121	1
	21	Port plate-rear C.C.W. <i>Piatto distributore post. antioraria</i>	Steuerplatte Linkslauf <i>Plato distribuidor trasero giro I</i>	Plaque arrière rotation gauche	BKR	034.67475			034.67475	1

Item Pos. Réf. Pos. Pos.	Description Descrizione	Benennung Descripción	Description		Part N° Teil Nr. Code N° Referencia T6EDC	Part N° Teil Nr. Code N° Referencia T6EDCM	Part N° Teil Nr. Code N° Referencia T6EDCS	Part N° Teil Nr. Code N° Referencia T6EDCR	Qty Stück Qt.à Cant.
21	Port plate-rear C.W. <i>Piatto distributore post. oraria</i>	Steuerplatte Rechtslauf <i>Plato distribuidor trasero giro D</i>	Plaque arrière rotation droite	BKR	034.67474			034.67474	1
	Port plate-rear <i>Piatto distributore post.</i>	Steuerplatte <i>Plato distribuidor trasero</i>	Plaque arrière	BK		034.59119	034.59119		1
22	Bush <i>Bussola</i>	Buchse <i>Cojinete de fricción</i>	Bague	BK NR		034.59901			1
23	Dowel pin <i>Spina</i>	Zentrierstift <i>Pasador</i>	Goupille	BK NR		323.82004			1
24	Dowel pin <i>Spina</i>	Zentrierstift <i>Pasador</i>	Goupille	AJP		323.82014			1
25	Vane <i>Paletta</i>	Flügel <i>Paleta</i>	Palette	AP		034.59162			12
26	Pin-vane holdout <i>Pistoncino di sostentamento</i>	Stößel <i>Espiga empuje paleta</i>	Poussoir de palette	AP	034.59161	034.70259	034.70259	034.59161	12
27	Round section ring <i>Anello elastico</i>	Sicherungsring <i>Anillo tórico</i>	Anneau	EFG		034.70866			1
28	Retaining ring <i>Anello elastico</i>	Sicherungsring <i>Anillo de retención</i>	Circlips			356.30315			1
29	Ball bearing <i>Cuscinetto a sfera</i>	Kugellager <i>Cojinete de bolas</i>	Roulement à billes	EFG		230.90018.3			1
30	Shaft seal (S1 - 0,7 bar) <i>Paraolio (S1 - 0,7 bar)</i>	Simmerring (S1 - 0,7 bar) <i>Reten eje (S1 - 0,7 bar)</i>	Joint d'arbre (S1 - 0,7 bar)	D		620.00022.3			1
	Shaft seal (S4 - S5 - 7 bar) <i>Paraolio (S4 - S5 - 7 bar)</i>	Simmerring (S4 - S5 - 7 bar) <i>Reten eje (S4 - S5 - 7 bar)</i>	Joint d'arbre (S4 - S5 - 7 bar)	D		620.00019.3			1
31a	Key (code 1) <i>Chiavetta (codice 1)</i>	Paßfeder (Typ 1) <i>Chaveta (codigo 1)</i>	Clavette (code 1)	E	034.66786	034.66786		034.66786	1
31b	Key (code 2) <i>Chiavetta (codice 2)</i>	Paßfeder (Typ 2) <i>Chaveta (codigo 2)</i>	Clavette (code 2)	G			034.66978		1
32a	Shaft (keyed) (code 1) <i>Albero a chiavetta (codice 1)</i>	Welle für Paßfeder (Typ 1) <i>Eje chaveteado (codigo 1)</i>	Arbre à clavette (code 1)	E	034.66785	034.66785		034.66795	1
32b	Shaft (splined) (code 3) <i>Albero a scanalato (codice 3)</i>	Vielkeilwelle (Typ 3) <i>Eje estriado (codigo 3)</i>	Arbre à cannelures (code 3)	F		034.66784	034.66784	034.66794	1
32c	Shaft (keyed) (code 2) <i>Albero a chiavetta (codice 2)</i>	Welle für Paßfeder (Typ 2) <i>Eje chaveteado (codigo 2)</i>	Arbre à clavette (code 2)	G			034.66977		1
33	Mounting cap <i>Coperchio anteriore</i>	Deckel <i>Tapa de montaje</i>	Chapeau de montage		034.66781	034.66781	034.66809	034.66781	1
34	Sq. section seal <i>Guarnizione</i>	Dichtring <i>Junta seccion cuadrada</i>	Joint section carrée	ADP		691.10237			1
35	Port plate-pressure C.C.W <i>Piatto distributore anter. antioraria</i>	Steuerplatte Linkslauf <i>Plato distribuidor-presión giro I</i>	Plaque pression rotation gauche	AP		034.59160			1
	Port plate-pressure C.W. <i>Piatto distributore anter. oraria</i>	Steuerplatte Rechtslauf <i>Plato distribuidor-presión giro D</i>	Plaque pression rotation droite	AP		034.59159			1
36	Sq. section seal <i>Guarnizione</i>	Dichtring <i>Junta seccion cuadrada</i>	Joint section carrée	ADP		691.10253			1
37	Back-up ring <i>Anello anti-estrusione</i>	Stützring <i>Anillo</i>	Bague anti-extrusion	ADP		618.00012.3			1
38	Sq. section seal <i>Guarnizione</i>	Dichtring <i>Junta seccion cuadrada</i>	Joint section carrée	ADP		671.10259			1
39	Rotor-insert ass'y <i>Insieme rotore</i>	Rotor <i>Conjunto rotor</i>	Rotor et douille ass.	AP	S24.10185	S24.30019	S24.30019	S24.10185	1



Item Pos. Ref. Pos. Pos.	Description Descrizione	Benennung Descripcion	Description		Part N° Teil Nr. Code N° Cod. N° Referencia T6EDC	Part N° Teil Nr. Code N° Cod. N° Referencia T6EDCM	Part N° Teil Nr. Code N° Cod. N° Referencia T6EDCS	Part N° Teil Nr. Code N° Cod. N° Referencia T6EDCR	Qty Stück Qt.à Cant.	
40	Cam ring 042 <i>Anello camma 042</i>	Hubring 042 <i>Aro volumetrico 042</i>	Came 042	AP	034.66899				1	
	Cam ring 045 <i>Anello camma 045</i>	Hubring 045 <i>Aro volumetrico 045</i>	Came 045	AP	034.59164				1	
	Cam ring 050 <i>Anello camma 050</i>	Hubring 050 <i>Aro volumetrico 050</i>	Came 050	AP	034.66744				1	
	Cam ring 052 <i>Anello camma 052</i>	Hubring 052 <i>Aro volumetrico 052</i>	Came 052	AP	034.59165				1	
	Cam ring 062 <i>Anello camma 062</i>	Hubring 062 <i>Aro volumetrico 062</i>	Came 062	AP	034.59166				1	
	Cam ring 066 <i>Anello camma 066</i>	Hubring 066 <i>Aro volumetrico 066</i>	Came 066	AP	034.59167				1	
	Cam ring 072 <i>Anello camma 072</i>	Hubring 072 <i>Aro volumetrico 072</i>	Came 072	AP	034.66736				1	
	41	Dowel pin <i>Spina</i>	Zentrierstift <i>Pasador</i>	Goupille	AP	324.22016				2
	42	Port plate-rear C.C.W. <i>Piatto distributore post. antioraria</i>	Steuerplatte Linkslauf <i>Plato distribuidor trasero giro I</i>	Plaque arrière rotation gauche	AJP	034.59083				1
Port plate-rear C.W. <i>Piatto distributore post. oraria</i>		Steuerplatte Rechtslauf <i>Plato distribuidor trasero giro D</i>	Plaque arrière rotation droite	AJP	034.59082				1	
44	Screw <i>Vite</i>	Schraube <i>Tornille</i>	Vis	AP	310.10340				2	
45	Dowel pin <i>Spina</i>	Zentrierstift <i>Pasador</i>	Goupille	BR	324.21612				2	
47	Screw <i>Vite</i>	Schraube <i>Tornille</i>	Vis	BR	317.10320				2	
48	Housing (pedestal mounting) <i>Corpo (piedestallo)</i>	Gehäuse (Socketmontage) <i>Cuerpo</i>	Carter (avec pied de montage)		034.66782	034.66782	034.66810	034.66782	1	
	Housing (face mounting) <i>Corpo (battuta)</i>	Gehäuse (Flanschmontage) <i>Cuerpo</i>	Carter (montage face)		034.66796	034.66796	034.66811	034.66796	1	
49	Sq. section seal <i>Guarnizione</i>	Dichtring <i>Junta seccion cuadrada</i>	Joint section carrée	BR	671.10259				1	
50	Screw <i>Vite</i>	Schraube <i>Tornille</i>	Vis		361.14464.3				4	
51	Port block <i>Coperchio intermedio</i>	Anschlußblock <i>Bloque distribuidor</i>	Palier		034.66783	034.66783	034.66812	034.66783	1	
52	Screw <i>Vite</i>	Schraube <i>Tornille</i>	Vis		361.14324.3				4	
53	Dowel pin <i>Spina</i>	Zentrierstift <i>Pasador</i>	Goupille	CL MS	323.82010				1	
54	Dowel pin <i>Spina</i>	Zentrierstift <i>Pasador</i>	Goupille	CS	324.21208				2	
55	Screw <i>Vite</i>	Schraube <i>Tornille</i>	Vis	CS	317.06266				2	
56	Screw <i>Vite</i>	Schraube <i>Tornille</i>	Vis		361.11264.3				7	

Item Pos. Réf. Pos. Pos.	Description Descrizione	Benennung Descripción	Description		Part N° Teil Nr. Code N° Cod. N° Referencia T6EDC	Part N° Teil Nr. Code N° Cod. N° Referencia T6EDCM	Part N° Teil Nr. Code N° Cod. N° Referencia T6EDCS	Part N° Teil Nr. Code N° Cod. N° Referencia T6EDCR	Qty Stück Qté Q.tà Cant.
57	Retaining ring <i>Anello elastico</i>	Sicherungsring <i>Anillo de retención</i>	Circlips	H				356.00033.3	1
58	Coupling (SAE A) <i>Giunto (SAE A)</i>	Kupplung (SAE A) <i>Accoplamiento (SAE A)</i>	Accouplement (SAE A)	H				034.66759	1
59	Sq. section seal <i>Guarnizione</i>	Dichtring <i>Junta seccion cuadrada</i>	Joint section carrée	D				671.10152	1
	<b>REPAIR KIT</b> <b>KIT DI RICAMBIO</b>	<b>AUSTAUSCH-BAUGRUPPEN</b> <b>CUNJUNTO REPARACION</b>	<b>POCHETTES RECHANGES</b>						
A	Cart. and plate ass'y 042 C.W. (P1) <i>Ins. cart. 042 oraria (P1)</i>	Pumpeneinheit 042 Rechtslauf (P1) <i>Conjunto cart. y platos 042 giro d. (P1)</i>	Cart. et plaque ass. 042 rot. d. (P1)		S24.49390	S24.49394	S24.49394	S24.49390	1
A	Cart. and plate ass'y 042 C.C.W. (P1) <i>Ins. cart. 042 antioraria (P1)</i>	Pumpeneinheit 042 Linkslauf (P1) <i>Conjunto cart. y platos 042 giro i. (P1)</i>	Cart. et plaque ass. 042 rot. g. (P1)		S24.49391	S24.49395	S24.49395	S24.49391	1
A	Cart. and plate ass'y 045 C.W. (P1) <i>Ins. cart. 045 oraria (P1)</i>	Pumpeneinheit 045 Rechtslauf (P1) <i>Conjunto cart. y platos 045 giro d. (P1)</i>	Cart. et plaque ass. 045 rot. d. (P1)		S24.10205	S24.40377	S24.40377	S24.10205	1
A	Cart. and plate ass'y 045 C.C.W. (P1) <i>Ins. cart. 045 antioraria (P1)</i>	Pumpeneinheit 045 Linkslauf (P1) <i>Conjunto cart. y platos 045 giro i. (P1)</i>	Cart. et plaque ass. 045 rot. g. (P1)		S24.10206	S24.40378	S24.40378	S24.10206	1
A	Cart. and plate ass'y 050 C.W. (P1) <i>Ins. cart. 050 oraria (P1)</i>	Pumpeneinheit 050 Rechtslauf (P1) <i>Conjunto cart. y platos 050 giro d. (P1)</i>	Cart. et plaque ass. 050 rot. d. (P1)		S24.40769	S24.40771	S24.40771	S24.40769	1
A	Cart. and plate ass'y 050 C.C.W. (P1) <i>Ins. cart. 050 antioraria (P1)</i>	Pumpeneinheit 050 Linkslauf (P1) <i>Conjunto cart. y platos 050 giro i. (P1)</i>	Cart. et plaque ass. 050 rot. g. (P1)		S24.40770	S24.40772	S24.40772	S24.40770	1
A	Cart. and plate ass'y 052 C.W. (P1) <i>Ins. cart. 052 oraria (P1)</i>	Pumpeneinheit 052 Rechtslauf (P1) <i>Conjunto cart. y platos 052 giro d. (P1)</i>	Cart. et plaque ass. 052 rot. d. (P1)		S24.10207	S24.40379	S24.40379	S24.10207	1
A	Cart. and plate ass'y 052 C.C.W. (P1) <i>Ins. cart. 052 antioraria (P1)</i>	Pumpeneinheit 052 Linkslauf (P1) <i>Conjunto cart. y platos 052 giro i. (P1)</i>	Cart. et plaque ass. 052 rot. g. (P1)		S24.10208	S24.40380	S24.40380	S24.10208	1
A	Cart. and plate ass'y 062 C.W. (P1) <i>Ins. cart. 062 oraria (P1)</i>	Pumpeneinheit 062 Rechtslauf (P1) <i>Conjunto cart. y platos 062 giro d. (P1)</i>	Cart. et plaque ass. 062 rot. d. (P1)		S24.10209	S24.40381	S24.40381	S24.10209	1
A	Cart. and plate ass'y 062 C.C.W. (P1) <i>Ins. cart. 062 antioraria (P1)</i>	Pumpeneinheit 062 Linkslauf (P1) <i>Conjunto cart. y platos 062 giro i. (P1)</i>	Cart. et plaque ass. 062 rot. g. (P1)		S24.10210	S24.40382	S24.40382	S24.10210	1
A	Cart. and plate ass'y 066 C.W. (P1) <i>Ins. cart. 066 oraria (P1)</i>	Pumpeneinheit 066 Rechtslauf (P1) <i>Conjunto cart. y platos 066 giro d. (P1)</i>	Cart. et plaque ass. 066 rot. d. (P1)		S24.10211	S24.40383	S24.40383	S24.10211	1
A	Cart. and plate ass'y 066 C.C.W. (P1) <i>Ins. cart. 066 antioraria (P1)</i>	Pumpeneinheit 066 Linkslauf (P1) <i>Conjunto cart. y platos 066 giro i. (P1)</i>	Cart. et plaque ass. 066 rot. g. (P1)		S24.10212	S24.40384	S24.40384	S24.10212	1
A	Cart. and plate ass'y 072 C.W. (P1) <i>Ins. cart. 072 oraria (P1)</i>	Pumpeneinheit 072 Rechtslauf (P1) <i>Conjunto cart. y platos 072 giro d. (P1)</i>	Cart. et plaque ass. 072 rot. d. (P1)		S24.40375	S24.40385	S24.40385	S24.40375	1
A	Cart. and plate ass'y 072 C.C.W. (P1) <i>Ins. cart. 072 antioraria (P1)</i>	Pumpeneinheit 072 Linkslauf (P1) <i>Conjunto cart. y platos 072 giro i. (P1)</i>	Cart. et plaque ass. 072 rot. g. (P1)		S24.40376	S24.40386	S24.40386	S24.40376	1
B	Cart. and plate ass'y *14 C.W. (P2) <i>Ins. cart. *14 oraria (P2)</i>	Pumpeneinheit *14 Rechtslauf (P2) <i>Conjunto cart. y platos *14 giro d. (P2)</i>	Cart. et plaque ass. *14 rot. d. (P2)		S24.40795	S24.40797	S24.40797	S24.40795	1
B	Cart. and plate ass'y *14 C.C.W. (P2) <i>Ins. cart. *14 antioraria (P2)</i>	Pumpeneinheit *14 Linkslauf (P2) <i>Conjunto cart. y platos *14 giro i. (P2)</i>	Cart. et plaque ass. *14 rot. g. (P2)		S24.40796	S24.40798	S24.40798	S24.40796	1
B	Cart. and plate ass'y *17 C.W. (P2) <i>Ins. cart. *17 oraria (P2)</i>	Pumpeneinheit *17 Rechtslauf (P2) <i>Conjunto cart. y platos *17 giro d. (P2)</i>	Cart. et plaque ass. *17 rot. d. (P2)		S24.68491	S24.68493	S24.68493	S24.68491	1
B	Cart. and plate ass'y *17 C.C.W. (P2) <i>Ins. cart. *17 antioraria (P2)</i>	Pumpeneinheit *17 Linkslauf (P2) <i>Conjunto cart. y platos *17 giro i. (P2)</i>	Cart. et plaque ass. *17 rot. g. (P2)		S24.68492	S24.68494	S24.68494	S24.68492	1
B	Cart. and plate ass'y *20 C.W. (P2) <i>Ins. cart. *20 oraria (P2)</i>	Pumpeneinheit *20 Rechtslauf (P2) <i>Conjunto cart. y platos *20 giro d. (P2)</i>	Cart. et plaque ass. *20 rot. d. (P2)		S24.26492	S24.40330	S24.40330	S24.26492	1
B	Cart. and plate ass'y *20 C.C.W. (P2) <i>Ins. cart. *20 antioraria (P2)</i>	Pumpeneinheit *20 Linkslauf (P2) <i>Conjunto cart. y platos *20 giro i. (P2)</i>	Cart. et plaque ass. *20 rot. g. (P2)		S24.26493	S24.40331	S24.40331	S24.26493	1

Item Pos. Réf. Pos. Pos.	Description Descrizione	Benennung Descripción	Description		Part N° Teil Nr. Code N° Cod. N° Referencia T6EDC	Part N° Teil Nr. Code N° Cod. N° Referencia T6EDCM	Part N° Teil Nr. Code N° Cod. N° Referencia T6EDCS	Part N° Teil Nr. Code N° Cod. N° Referencia T6EDCR	Qty Stück Qté Q.tà Cant.
B	Cart. and plate ass'y *24 C.W. (P2) <i>Ins. cart. *24 oraria (P2)</i>	Pumpeneinheit *24 Rechtslauf (P2) <i>Conjunto cart. y platos *24 giro d. (P2)</i>	Cart. et plaque ass. *24 rot. d. (P2)		S24.25893	S24.40332	S24.40332	S24.25893	1
B	Cart. and plate ass'y *24 C.C.W. (P2) <i>Ins. cart. *24 antioraria (P2)</i>	Pumpeneinheit *24 Linkslauf (P2) <i>Conjunto cart. y platos *24 giro i. (P2)</i>	Cart. et plaque ass. *24 rot. g. (P2)		S24.25894	S24.40333	S24.40333	S24.25894	1
B	Cart. and plate ass'y *28 C.W. (P2) <i>Ins. cart. *28 oraria (P2)</i>	Pumpeneinheit *28 Rechtslauf (P2) <i>Conjunto cart. y platos *28 giro d. (P2)</i>	Cart. et plaque ass. *28 rot. d. (P2)		S24.10861	S24.40334	S24.40334	S24.10861	1
B	Cart. and plate ass'y *28 C.C.W. (P2) <i>Ins. cart. *28 antioraria (P2)</i>	Pumpeneinheit *28 Linkslauf (P2) <i>Conjunto cart. y platos *28 giro i. (P2)</i>	Cart. et plaque ass. *28 rot. g. (P2)		S24.10862	S24.40335	S24.40335	S24.10862	1
B	Cart. and plate ass'y *31 C.W. (P2) <i>Ins. cart. *31 oraria (P2)</i>	Pumpeneinheit *31 Rechtslauf (P2) <i>Conjunto cart. y platos *31 giro d. (P2)</i>	Cart. et plaque ass. *31 rot. d. (P2)		S24.10863	S24.40336	S24.40336	S24.10863	1
B	Cart. and plate ass'y *31 C.C.W. (P2) <i>Ins. cart. *31 antioraria (P2)</i>	Pumpeneinheit *31 Linkslauf (P2) <i>Conjunto cart. y platos *31 giro i. (P2)</i>	Cart. et plaque ass. *31 rot. g. (P2)		S24.10864	S24.40337	S24.40337	S24.10864	1
B	Cart. and plate ass'y *35 C.W. (P2) <i>Ins. cart. *35 oraria (P2)</i>	Pumpeneinheit *35 Rechtslauf (P2) <i>Conjunto cart. y platos *35 giro d. (P2)</i>	Cart. et plaque ass. *35 rot. d. (P2)		S24.10865	S24.40338	S24.40338	S24.10865	1
B	Cart. and plate ass'y *35 C.C.W. (P2) <i>Ins. cart. *35 antioraria (P2)</i>	Pumpeneinheit *35 Linkslauf (P2) <i>Conjunto cart. y platos *35 giro i. (P2)</i>	Cart. et plaque ass. *35 rot. g. (P2)		S24.10866	S24.40339	S24.40339	S24.10866	1
B	Cart. and plate ass'y *38 C.W. (P2) <i>Ins. cart. *38 oraria (P2)</i>	Pumpeneinheit *38 Rechtslauf (P2) <i>Conjunto cart. y platos *38 giro d. (P2)</i>	Cart. et plaque ass. *38 rot. d. (P2)		S24.10867	S24.40340	S24.40340	S24.10867	1
B	Cart. and plate ass'y *38 C.C.W. (P2) <i>Ins. cart. *38 antioraria (P2)</i>	Pumpeneinheit *38 Linkslauf (P2) <i>Conjunto cart. y platos *38 giro i. (P2)</i>	Cart. et plaque ass. *38 rot. g. (P2)		S24.10868	S24.40341	S24.40341	S24.10868	1
B	Cart. and plate ass'y *42 C.W. (P2) <i>Ins. cart. *42 oraria (P2)</i>	Pumpeneinheit *42 Rechtslauf (P2) <i>Conjunto cart. y platos *42 giro d. (P2)</i>	Cart. et plaque ass. *42 rot. d. (P2)		S24.10869	S24.40342	S24.40342	S24.10869	1
B	Cart. and plate ass'y *42 C.C.W. (P2) <i>Ins. cart. *42 antioraria (P2)</i>	Pumpeneinheit *42 Linkslauf (P2) <i>Conjunto cart. y platos *42 giro i. (P2)</i>	Cart. et plaque ass. *42 rot. g. (P2)		S24.10870	S24.40343	S24.40343	S24.10870	1
B	Cart. and plate ass'y *45 C.W. (P2) <i>Ins. cart. *45 oraria (P2)</i>	Pumpeneinheit *45 Rechtslauf (P2) <i>Conjunto cart. y platos *45 giro d. (P2)</i>	Cart. et plaque ass. *45 rot. d. (P2)		S24.10871	S24.40344	S24.40344	S24.10871	1
B	Cart. and plate ass'y *45 C.C.W. (P2) <i>Ins. cart. *45 antioraria (P2)</i>	Pumpeneinheit *45 Linkslauf (P2) <i>Conjunto cart. y platos *45 giro i. (P2)</i>	Cart. et plaque ass. *45 rot. g. (P2)		S24.10872	S24.40345	S24.40345	S24.10872	1
B	Cart. and plate ass'y *50 C.W. (P2) <i>Ins. cart. *50 oraria (P2)</i>	Pumpeneinheit *50 Rechtslauf (P2) <i>Conjunto cart. y platos *50 giro d. (P2)</i>	Cart. et plaque ass. *50 rot. d. (P2)		S24.40387	S24.40346	S24.40346	S24.40387	1
B	Cart. and plate ass'y *50 C.C.W. (P2) <i>Ins. cart. *50 antioraria (P2)</i>	Pumpeneinheit *50 Linkslauf (P2) <i>Conjunto cart. y platos *50 giro i. (P2)</i>	Cart. et plaque ass. *50 rot. g. (P2)		S24.40388	S24.40347	S24.40347	S24.40388	1
C	Cart. and plate ass'y *03 C.W. (P3) <i>Ins. cart. *03 oraria (P3)</i>	Pumpeneinheit *03 Rechtslauf (P3) <i>Conjunto cart. y platos *03 giro d. (P3)</i>	Cart. et plaque ass. *03 rot. d. (P3)		S24.10749	S24.40200	S24.40200	S24.10749	1
C	Cart. and plate ass'y *03 C.C.W. (P3) <i>Ins. cart. *03 antioraria (P3)</i>	Pumpeneinheit *03 Linkslauf (P3) <i>Conjunto cart. y platos *03 giro i. (P3)</i>	Cart. et plaque ass. *03 rot. g. (P3)		S24.10750	S24.40201	S24.40201	S24.10750	1
C	Cart. and plate ass'y *05 C.W. (P3) <i>Ins. cart. *05 oraria (P3)</i>	Pumpeneinheit *05 Rechtslauf (P3) <i>Conjunto cart. y platos *05 giro d. (P3)</i>	Cart. et plaque ass. *05 rot. d. (P3)		S24.10751	S24.40202	S24.40202	S24.10751	1
C	Cart. and plate ass'y *05 C.C.W. (P3) <i>Ins. cart. *05 antioraria (P3)</i>	Pumpeneinheit *05 Linkslauf (P3) <i>Conjunto cart. y platos *05 giro i. (P3)</i>	Cart. et plaque ass. *05 rot. g. (P3)		S24.10752	S24.40203	S24.40203	S24.10752	1
C	Cart. and plate ass'y *06 C.W. (P3) <i>Ins. cart. *06 oraria (P3)</i>	Pumpeneinheit *06 Rechtslauf (P3) <i>Conjunto cart. y platos *06 giro d. (P3)</i>	Cart. et plaque ass. *06 rot. d. (P3)		S24.10753	S24.40204	S24.40204	S24.10753	1
C	Cart. and plate ass'y *06 C.C.W. (P3) <i>Ins. cart. *06 antioraria (P3)</i>	Pumpeneinheit *06 Linkslauf (P3) <i>Conjunto cart. y platos *06 giro i. (P3)</i>	Cart. et plaque ass. *06 rot. g. (P3)		S24.10754	S24.40205	S24.40205	S24.10754	1
C	Cart. and plate ass'y *08 C.W. (P3) <i>Ins. cart. *08 oraria (P3)</i>	Pumpeneinheit *08 Rechtslauf (P3) <i>Conjunto cart. y platos *08 giro d. (P3)</i>	Cart. et plaque ass. *08 rot. d. (P3)		S24.10755	S24.40206	S24.40206	S24.10755	1
C	Cart. and plate ass'y *08 C.C.W. (P3) <i>Ins. cart. *08 antioraria (P3)</i>	Pumpeneinheit *08 Linkslauf (P3) <i>Conjunto cart. y platos *08 giro i. (P3)</i>	Cart. et plaque ass. *08 rot. g. (P3)		S24.10756	S24.40207	S24.40207	S24.10756	1
C	Cart. and plate ass'y *10 C.W. (P3) <i>Ins. cart. *10 oraria (P3)</i>	Pumpeneinheit *10 Rechtslauf (P3) <i>Conjunto cart. y platos *10 giro d. (P3)</i>	Cart. et plaque ass. *10 rot. d. (P3)		S24.10757	S24.40208	S24.40208	S24.10757	1

Item Pos. Réf. Pos. Pos.	Description Descrizione	Benennung Descrpcion	Description	Part N° Teil Nr. Code N° Cod. N° Referencia T6EDC	Part N° Teil Nr. Code N° Cod. N° Referencia T6EDCM	Part N° Teil Nr. Code N° Cod. N° Referencia T6EDCS	Part N° Teil Nr. Code N° Cod. N° Referencia T6EDCR	Qty Stück Qt.à Cant.
C	Cart. and plate ass'y *10 C.C.W. (P3) <i>Ins. cart. *10 antioraria (P3)</i>	Pumpeneinheit *10 Linkslauf (P3) <i>Conjunto cart. y platos *10 giro i. (P3)</i>	Cart. et plaque ass. *10 rot. g. (P3)	S24.10758	S24.40209	S24.40209	S24.10758	1
C	Cart. and plate ass'y *12 C.C.W. (P3) <i>Ins. cart. *12 oraria (P3)</i>	Pumpeneinheit *12 Rechtslauf (P3) <i>Conjunto cart. y platos *12 giro d. (P3)</i>	Cart. et plaque ass. *12 rot. d. (P3)	S24.26482	S24.40210	S24.40210	S24.26482	1
C	Cart. and plate ass'y *12 C.C.W. (P3) <i>Ins. cart. *12 antioraria (P3)</i>	Pumpeneinheit *12 Linkslauf (P3) <i>Conjunto cart. y platos *12 giro i. (P3)</i>	Cart. et plaque ass. *12 rot. g. (P3)	S24.26483	S24.40211	S24.40211	S24.26483	1
C	Cart. and plate ass'y *14 C.C.W. (P3) <i>Ins. cart. *14 oraria (P3)</i>	Pumpeneinheit *14 Rechtslauf (P3) <i>Conjunto cart. y platos *14 giro d. (P3)</i>	Cart. et plaque ass. *14 rot. d. (P3)	S24.10759	S24.40212	S24.40212	S24.10759	1
C	Cart. and plate ass'y *14 C.C.W. (P3) <i>Ins. cart. *14 antioraria (P3)</i>	Pumpeneinheit *14 Linkslauf (P3) <i>Conjunto cart. y platos *14 giro i. (P3)</i>	Cart. et plaque ass. *14 rot. g. (P3)	S24.10760	S24.40213	S24.40213	S24.10760	1
C	Cart. and plate ass'y *17 C.C.W. (P3) <i>Ins. cart. *17 oraria (P3)</i>	Pumpeneinheit *17 Rechtslauf (P3) <i>Conjunto cart. y platos *17 giro d. (P3)</i>	Cart. et plaque ass. *17 rot. d. (P3)	S24.10761	S24.40214	S24.40214	S24.10761	1
C	Cart. and plate ass'y *17 C.C.W. (P3) <i>Ins. cart. *17 antioraria (P3)</i>	Pumpeneinheit *17 Linkslauf (P3) <i>Conjunto cart. y platos *17 giro i. (P3)</i>	Cart. et plaque ass. *17 rot. g. (P3)	S24.10762	S24.40215	S24.40215	S24.10762	1
C	Cart. and plate ass'y *20 C.C.W. (P3) <i>Ins. cart. *20 oraria (P3)</i>	Pumpeneinheit *20 Rechtslauf (P3) <i>Conjunto cart. y platos *20 giro d. (P3)</i>	Cart. et plaque ass. *20 rot. d. (P3)	S24.31023	S24.40216	S24.40216	S24.31023	1
C	Cart. and plate ass'y *20 C.C.W. (P3) <i>Ins. cart. *20 antioraria (P3)</i>	Pumpeneinheit *20 Linkslauf (P3) <i>Conjunto cart. y platos *20 giro i. (P3)</i>	Cart. et plaque ass. *20 rot. g. (P3)	S24.40032	S24.40217	S24.40217	S24.40032	1
C	Cart. and plate ass'y *22 C.C.W. (P3) <i>Ins. cart. *22 oraria (P3)</i>	Pumpeneinheit *22 Rechtslauf (P3) <i>Conjunto cart. y platos *22 giro d. (P3)</i>	Cart. et plaque ass. *22 rot. d. (P3)	S24.10763	S24.40218	S24.40218	S24.10763	1
C	Cart. and plate ass'y *22 C.C.W. (P3) <i>Ins. cart. *22 antioraria (P3)</i>	Pumpeneinheit *22 Linkslauf (P3) <i>Conjunto cart. y platos *22 giro i. (P3)</i>	Cart. et plaque ass. *22 rot. g. (P3)	S24.10764	S24.40219	S24.40219	S24.10764	1
C	Cart. and plate ass'y *25 C.C.W. (P3) <i>Ins. cart. *25 oraria (P3)</i>	Pumpeneinheit *25 Rechtslauf (P3) <i>Conjunto cart. y platos *25 giro d. (P3)</i>	Cart. et plaque ass. *25 rot. d. (P3)	S24.10765	S24.40220	S24.40220	S24.10765	1
C	Cart. and plate ass'y *25 C.C.W. (P3) <i>Ins. cart. *25 antioraria (P3)</i>	Pumpeneinheit *25 Linkslauf (P3) <i>Conjunto cart. y platos *25 giro i. (P3)</i>	Cart. et plaque ass. *25 rot. g. (P3)	S24.10766	S24.40221	S24.40221	S24.10766	1
C	Cart. and plate ass'y *28 C.C.W. (P3) <i>Ins. cart. *28 oraria (P3)</i>	Pumpeneinheit *28 Rechtslauf (P3) <i>Conjunto cart. y platos *28 giro d. (P3)</i>	Cart. et plaque ass. *28 rot. d. (P3)	S24.25547	S24.40222	S24.40222	S24.25547	1
C	Cart. and plate ass'y *28 C.C.W. (P3) <i>Ins. cart. *28 antioraria (P3)</i>	Pumpeneinheit *28 Linkslauf (P3) <i>Conjunto cart. y platos *28 giro i. (P3)</i>	Cart. et plaque ass. *28 rot. g. (P3)	S24.25546	S24.40223	S24.40223	S24.25546	1
C	Cart. and plate ass'y *31 C.C.W. (P3) <i>Ins. cart. *31 oraria (P3)</i>	Pumpeneinheit *31 Rechtslauf (P3) <i>Conjunto cart. y platos *31 giro d. (P3)</i>	Cart. et plaque ass. *31 rot. d. (P3)	S24.45771	S24.45775	S24.45775	S24.45771	1
C	Cart. and plate ass'y *31 C.C.W. (P3) <i>Ins. cart. *31 antioraria (P3)</i>	Pumpeneinheit *31 Linkslauf (P3) <i>Conjunto cart. y platos *31 giro i. (P3)</i>	Cart. et plaque ass. *31 rot. g. (P3)	S24.45772	S24.45776	S24.45775	S24.45772	1
D	Seal kit (S1 - 0,7 bar) <i>Serie guarnizioni (S1 - 0,7 bar)</i>	Dichtringsatz (S1 - 0,7 bar) <i>Juego de juntas (S1 - 0,7 bar)</i>	Pochette de joint (S1 - 0,7 bar)	S24.44823		S24.44977		1
	Seal kit (S4 - 7 bar) <i>Serie guarnizioni (S4 - 7 bar)</i>	Dichtringsatz (S4 - 7 bar) <i>Juego de juntas (S4 - 7 bar)</i>	Pochette de joint (S4 - 7 bar)	S24.44823.4		S24.44977.4		1
	Seal kit (S5 - 7 bar) <i>Serie guarnizioni (S5 - 7 bar)</i>	Dichtringsatz (S5 - 7 bar) <i>Juego de juntas (S5 - 7 bar)</i>	Pochette de joint (S5 - 7 bar)	S24.44823.5		S24.44977.5		1
E	Shaft and bearing ass'y (code 1) <i>Ins. albero (codice 1)</i>	Baugruppe (Welle u. Lager) (Typ 1) <i>Conjunto eje cojinete (codigo 1)</i>	Arbre et roulement ass. (code 1)	S24.44516	S24.44516		S24.44979	1
F	Shaft and bearing ass'y (code 3) <i>Ins. albero (codice 3)</i>	Baugruppe (Welle u. Lager) (Typ 3) <i>Conjunto eje cojinete (codigo 3)</i>	Arbre et roulement ass. (code 3)		S24.44517	S24.44517	S24.44978	1
G	Shaft and bearing ass'y (code 2) <i>Ins. albero (codice 2)</i>	Baugruppe (Welle u. Lager) (Typ 2) <i>Conjunto eje cojinete (codigo 2)</i>	Arbre et roulement ass. (code 2)			S24.51348		1
H	Coupling (SAE A) ass'y <i>Ins. giunto (SAE A)</i>	Kupplung (SAE A) <i>Conj. accoplamento (SAE A)</i>	Accouplement (SAE A)				S24.40369	1
J	Port plate rear ass'y C.C.W. (P1) <i>Ins. piatto distributore post. antioraria (P1)</i>	Steuerplatte Linkslauf (P1) <i>Conj. plato dist. trasero giro I (P1)</i>	Plaque arrière ass. rot. gauche (P1)	S24.10215				1

Item Pos. Réf. Pos. Pos.	Description Descrizione	Benennung Descripción	Description		Part N° Teil Nr. Code N° Cod. N° Referencia T6EDC	Part N° Teil Nr. Code N° Cod. N° Referencia T6EDCM	Part N° Teil Nr. Code N° Cod. N° Referencia T6EDCS	Part N° Teil Nr. Code N° Cod. N° Referencia T6EDCR	Qty Stück Qté Q.tà Cant.
J	Port plate rear ass'y C.W. (P1) <i>Ins. piatto distributore post. oraria (P1)</i>	Steuerplatte Rechtslauf (P1) <i>Conj. plato dist. trasero giro D (P1)</i>	Plaque arrière ass. rot. droite (P1)		S24.10214				1
K	Port plate rear and bush ass'y C.C.W. (P2) <i>Ins. piatto distributore post. antioraria (P2)</i>	Steuerplatte mit Buchse Linkslauf (P2) <i>Conj. plato dist. tras. con coj. fricción giro I (P2)</i>	Plaque arrière et bague ass. rot. gauche (P2)	S14.76149			S14.76149	1	
	Port plate rear and bush ass'y C.W. (P2) <i>Ins. piatto distributore post. oraria (P2)</i>	Steuerplatte mit Buchse Rechtslauf (P2) <i>Conj. plato dist. tras. con coj. fricción giro D (P2)</i>	Plaque arrière et bague ass. rot. droite (P2)	S24.76148			S24.76148	1	
	Port plate rear and bush ass'y (P2) <i>Ins. piatto distributore post. (P2)</i>	Steuerplatte mit Buchse (P2) <i>Conj. plato dist. tras. con coj. fricción (P2)</i>	Plaque arrière et bague ass. (P2)		S24.10216	S24.10216		1	
L	Port plate rear and bush ass'y C.C.W. (P3) <i>Ins. piatto distributore post. antioraria (P3)</i>	Steuerplatte mit Buchse Linkslauf (P3) <i>Conj. plato dist. tras. con coj. fricción giro I (P3)</i>	Plaque arrière et bague ass. rot. gauche (P3)	S14.10808			S14.10808	1	
	Port plate rear and bush ass'y C.W. (P3) <i>Ins. piatto distributore post. oraria (P3)</i>	Steuerplatte mit Buchse Rechtslauf (P3) <i>Conj. plato dist. tras. con coj. fricción giro D (P3)</i>	Plaque arrière et bague ass. rot. droite (P3)	S24.10807			S24.10807	1	
	Port plate rear and bush ass'y (P3) <i>Ins. piatto distributore post. (P3)</i>	Steuerplatte mit Buchse (P3) <i>Conj. plato dist. tras. con coj. fricción (P3)</i>	Plaque arrière et bague ass. (P3)		S24.10349	S24.10349		1	
	* = 0 = uni-rotational * = 0 = <i>unirotazionale</i>	* = 0 = Eine Drehrichtung * = 0 = <i>uni-direccional</i>	* = 0 = Unirotationnelle						
	* = B = bi-rotational * = B = <i>Birotazionale</i>	* = B = Beide Drehrichtung * = B = <i>bi-direccional</i>	* = B = Birotationnelle						
	<b>For option Mobil version bi-rotational</b> <b>Per Mobile opzioni-Birotazionale</b>	<b>Für Mobil-Optionen-Beide Drehrichtung</b>	<b>Pour option Mobile Version bi-rotationnelle</b>						
3	Port plate-pressure <i>Piatto distributore anter.</i>	Steuerplatte <i>Plato distribuidor-presión</i>	Plaque pression				034.66453	1	
8	Pin-vane holdout <i>Pistoncino di sostentamento</i>	Stößel <i>Espiga empuje paleta</i>	Poussoir de palette				034.24982	10	
9	Vane <i>Paletta</i>	Flügel <i>Paleta</i>	Palette				034.66716	10	
10	Rotor-insert ass'y <i>Insieme rotore</i>	Rotor <i>Conjunto rotor</i>	Rotor et douille ass.				S24.30049	1	
11	Port plate-rear <i>Piatto distributore post.</i>	Steuerplatte <i>Plato distribuidor trasero</i>	Plaque arrière				034.59118	1	
14	Port plate-pressure <i>Piatto distributore anter.</i>	Steuerplatte <i>Plato distribuidor-presión</i>	Plaque pression				034.59057	1	
19	Pin-vane holdout <i>Pistoncino di sostentamento</i>	Stößel <i>Espiga empuje paleta</i>	Poussoir de palette				034.24984	10	
20	Rotor-insert ass'y <i>Insieme rotore</i>	Rotor <i>Conjunto rotor</i>	Rotor et douille ass.				S24.30018	1	
21	Port plate-rear <i>Piatto distributore post.</i>	Steuerplatte <i>Plato distribuidor trasero</i>	Plaque arrière				034.59119	1	
26	Pin-vane holdout <i>Pistoncino di sostentamento</i>	Stößel <i>Espiga empuje paleta</i>	Poussoir de palette				034.70259	12	
39	Rotor-insert ass'y <i>Insieme rotore</i>	Rotor <i>Conjunto rotor</i>	Rotor et douille ass.				S24.30019	1	
	<b>REPAIR KIT</b> <b>KIT DI RICAMBIO</b>	<b>AUSTAUSCH-BAUGRUPPEN</b> <b>CUNJUNTO REPARACION</b>	<b>POCHETTES RECHANGES</b>						
M	Port plate rear ass'y (P3) <i>Ins. piatto distributore post. (P3)</i>	Steuerplatte Rechtslauf (P3) <i>Conj. plato dist. trasero (P3)</i>	Plaque arrière ass. (P3)				S24.10349	1	

Item Pos. Réf. Pos. Pos.	Description Descrizione	Benennung Descripción	Description	Part N° Teil Nr. Code N° Cod. N° Referencia T6EDC	Part N° Teil Nr. Code N° Cod. N° Referencia T6EDCM	Part N° Teil Nr. Code N° Cod. N° Referencia T6EDCS	Part N° Teil Nr. Code N° Cod. N° Referencia T6EDCR	Qty Stück Qté Q.tà Cant.
N	Port plate rear ass'y (P2) <i>Ins. piatto distributore post. (P2)</i>	Steuerplatte Rechtslauf (P2) <i>Conj. plato dist. trasero (P2)</i>	Plaque arrière ass. (P2)				S24.10216	1
P	Cart. and plate ass'y 042 C.W. (P1) <i>Ins. cart. 042 oraria (P1)</i>	Pumpeneinheit 042 Rechtslauf (P1) <i>Conjunto cart. y platos 042 giro d. (P1)</i>	Cart. et plaque ass. 042 rot. d. (P1)				S24.49394	1
P	Cart. and plate ass'y 042 C.C.W. (P1) <i>Ins. cart. 042 antioraria (P1)</i>	Pumpeneinheit 042 Linkslauf (P1) <i>Conjunto cart. y platos 042 giro i. (P1)</i>	Cart. et plaque ass. 042 rot. g. (P1)				S24.49395	1
P	Cart. and plate ass'y 045 C.W. (P1) <i>Ins. cart. 045 oraria (P1)</i>	Pumpeneinheit 045 Rechtslauf (P1) <i>Conjunto cart. y platos 045 giro d. (P1)</i>	Cart. et plaque ass. 045 rot. d. (P1)				S24.40377	1
P	Cart. and plate ass'y 045 C.C.W. (P1) <i>Ins. cart. 045 antioraria (P1)</i>	Pumpeneinheit 045 Linkslauf (P1) <i>Conjunto cart. y platos 045 giro i. (P1)</i>	Cart. et plaque ass. 045 rot. g. (P1)				S24.40378	1
P	Cart. and plate ass'y 050 C.W. (P1) <i>Ins. cart. 050 oraria (P1)</i>	Pumpeneinheit 050 Rechtslauf (P1) <i>Conjunto cart. y platos 050 giro d. (P1)</i>	Cart. et plaque ass. 050 rot. d. (P1)				S24.40771	1
P	Cart. and plate ass'y 050 C.C.W. (P1) <i>Ins. cart. 050 antioraria (P1)</i>	Pumpeneinheit 050 Linkslauf (P1) <i>Conjunto cart. y platos 050 giro i. (P1)</i>	Cart. et plaque ass. 050 rot. g. (P1)				S24.40772	1
P	Cart. and plate ass'y 052 C.W. (P1) <i>Ins. cart. 052 oraria (P1)</i>	Pumpeneinheit 052 Rechtslauf (P1) <i>Conjunto cart. y platos 052 giro d. (P1)</i>	Cart. et plaque ass. 052 rot. d. (P1)				S24.40379	1
P	Cart. and plate ass'y 052 C.C.W. (P1) <i>Ins. cart. 052 antioraria (P1)</i>	Pumpeneinheit 052 Linkslauf (P1) <i>Conjunto cart. y platos 052 giro i. (P1)</i>	Cart. et plaque ass. 052 rot. g. (P1)				S24.40380	1
P	Cart. and plate ass'y 062 C.W. (P1) <i>Ins. cart. 062 oraria (P1)</i>	Pumpeneinheit 062 Rechtslauf (P1) <i>Conjunto cart. y platos 062 giro d. (P1)</i>	Cart. et plaque ass. 062 rot. d. (P1)				S24.40381	1
P	Cart. and plate ass'y 062 C.C.W. (P1) <i>Ins. cart. 062 antioraria (P1)</i>	Pumpeneinheit 062 Linkslauf (P1) <i>Conjunto cart. y platos 062 giro i. (P1)</i>	Cart. et plaque ass. 062 rot. g. (P1)				S24.40382	1
P	Cart. and plate ass'y 066 C.W. (P1) <i>Ins. cart. 066 oraria (P1)</i>	Pumpeneinheit 066 Rechtslauf (P1) <i>Conjunto cart. y platos 066 giro d. (P1)</i>	Cart. et plaque ass. 066 rot. d. (P1)				S24.40383	1
P	Cart. and plate ass'y 066 C.C.W. (P1) <i>Ins. cart. 066 antioraria (P1)</i>	Pumpeneinheit 066 Linkslauf (P1) <i>Conjunto cart. y platos 066 giro i. (P1)</i>	Cart. et plaque ass. 066 rot. g. (P1)				S24.40384	1
P	Cart. and plate ass'y 072 C.W. (P1) <i>Ins. cart. 072 oraria (P1)</i>	Pumpeneinheit 072 Rechtslauf (P1) <i>Conjunto cart. y platos 072 giro d. (P1)</i>	Cart. et plaque ass. 072 rot. d. (P1)				S24.40385	1
P	Cart. and plate ass'y 072 C.C.W. (P1) <i>Ins. cart. 072 antioraria (P1)</i>	Pumpeneinheit 072 Linkslauf (P1) <i>Conjunto cart. y platos 072 giro i. (P1)</i>	Cart. et plaque ass. 072 rot. g. (P1)				S24.40386	1
R	Cart. and plate ass'y B14 C.W. (P2) <i>Ins. cart. B14 oraria (P2)</i>	Pumpeneinheit B14 Rechtslauf (P2) <i>Conjunto cart. y platos B14 giro d. (P2)</i>	Cart. et plaque ass. B14 rot. d. (P2)				S24.40797	1
R	Cart. and plate ass'y B14 C.C.W. (P2) <i>Ins. cart. B14 antioraria (P2)</i>	Pumpeneinheit B14 Linkslauf (P2) <i>Conjunto cart. y platos B14 giro i. (P2)</i>	Cart. et plaque ass. B14 rot. g. (P2)				S24.40798	1
R	Cart. and plate ass'y B17 C.W. (P2) <i>Ins. cart. B17 oraria (P2)</i>	Pumpeneinheit B17 Rechtslauf (P2) <i>Conjunto cart. y platos B17 giro d. (P2)</i>	Cart. et plaque ass. B17 rot. d. (P2)				S24.68493	1
R	Cart. and plate ass'y B17 C.C.W. (P2) <i>Ins. cart. B17 antioraria (P2)</i>	Pumpeneinheit B17 Linkslauf (P2) <i>Conjunto cart. y platos B17 giro i. (P2)</i>	Cart. et plaque ass. B17 rot. g. (P2)				S24.68494	1
R	Cart. and plate ass'y B20 C.W. (P2) <i>Ins. cart. B20 oraria (P2)</i>	Pumpeneinheit B20 Rechtslauf (P2) <i>Conjunto cart. y platos B20 giro d. (P2)</i>	Cart. et plaque ass. B20 rot. d. (P2)				S24.40330	1
R	Cart. and plate ass'y B20 C.C.W. (P2) <i>Ins. cart. B20 antioraria (P2)</i>	Pumpeneinheit B20 Linkslauf (P2) <i>Conjunto cart. y platos B20 giro i. (P2)</i>	Cart. et plaque ass. B20 rot. g. (P2)				S24.40331	1
R	Cart. and plate ass'y B24 C.W. (P2) <i>Ins. cart. B24 oraria (P2)</i>	Pumpeneinheit B24 Rechtslauf (P2) <i>Conjunto cart. y platos B24 giro d. (P2)</i>	Cart. et plaque ass. B24 rot. d. (P2)				S24.40332	1
R	Cart. and plate ass'y B24 C.C.W. (P2) <i>Ins. cart. B24 antioraria (P2)</i>	Pumpeneinheit B24 Linkslauf (P2) <i>Conjunto cart. y platos B24 giro i. (P2)</i>	Cart. et plaque ass. B24 rot. g. (P2)				S24.40333	1
R	Cart. and plate ass'y B28 C.W. (P2) <i>Ins. cart. B28 oraria (P2)</i>	Pumpeneinheit B28 Rechtslauf (P2) <i>Conjunto cart. y platos B28 giro d. (P2)</i>	Cart. et plaque ass. B28 rot. d. (P2)				S24.40334	1
R	Cart. and plate ass'y B28 C.C.W. (P2) <i>Ins. cart. B28 antioraria (P2)</i>	Pumpeneinheit B28 Linkslauf (P2) <i>Conjunto cart. y platos B28 giro i. (P2)</i>	Cart. et plaque ass. B28 rot. g. (P2)				S24.40335	1

Item Pos. Réf. Pos. Pos.	Description Descrizione	Benennung Descripción	Description	Part N° Teil Nr. Code N° Referencia T6EDC	Part N° Teil Nr. Code N° Referencia T6EDCM	Part N° Teil Nr. Code N° Referencia T6EDCS	Part N° Teil Nr. Code N° Referencia T6EDCR	Qty Stück Qté Q.tà Cant.
R	Cart. and plate ass'y B31 C.W. (P2) <i>Ins. cart. B31 oraria (P2)</i>	Pumpeneinheit B31 Rechtslauf (P2) <i>Conjunto cart. y platos B31 giro d. (P2)</i>	Cart. et plaque ass. B31 rot. d. (P2)				S24.40336	1
R	Cart. and plate ass'y B31 C.C.W. (P2) <i>Ins. cart. B31 antioraria (P2)</i>	Pumpeneinheit B31 Linkslauf (P2) <i>Conjunto cart. y platos B31 giro i. (P2)</i>	Cart. et plaque ass. B31 rot. g. (P2)				S24.40337	1
R	Cart. and plate ass'y B35 C.W. (P2) <i>Ins. cart. B35 oraria (P2)</i>	Pumpeneinheit B35 Rechtslauf (P2) <i>Conjunto cart. y platos B35 giro d. (P2)</i>	Cart. et plaque ass. B35 rot. d. (P2)				S24.40338	1
R	Cart. and plate ass'y B35 C.C.W. (P2) <i>Ins. cart. B35 antioraria (P2)</i>	Pumpeneinheit B35 Linkslauf (P2) <i>Conjunto cart. y platos B35 giro i. (P2)</i>	Cart. et plaque ass. B35 rot. g. (P2)				S24.40339	1
R	Cart. and plate ass'y B38 C.W. (P2) <i>Ins. cart. B38 oraria (P2)</i>	Pumpeneinheit B38 Rechtslauf (P2) <i>Conjunto cart. y platos B38 giro d. (P2)</i>	Cart. et plaque ass. B38 rot. d. (P2)				S24.40340	1
R	Cart. and plate ass'y B38 C.C.W. (P2) <i>Ins. cart. B38 antioraria (P2)</i>	Pumpeneinheit B38 Linkslauf (P2) <i>Conjunto cart. y platos B38 giro i. (P2)</i>	Cart. et plaque ass. B38 rot. g. (P2)				S24.40341	1
R	Cart. and plate ass'y 042 C.W. (P2) <i>Ins. cart. 042 oraria (P2)</i>	Pumpeneinheit 042 Rechtslauf (P2) <i>Conjunto cart. y platos 042 giro d. (P2)</i>	Cart. et plaque ass. 042 rot. d. (P2)				S24.40342	1
R	Cart. and plate ass'y 042 C.C.W. (P2) <i>Ins. cart. 042 antioraria (P2)</i>	Pumpeneinheit 042 Linkslauf (P2) <i>Conjunto cart. y platos 042 giro i. (P2)</i>	Cart. et plaque ass. 042 rot. g. (P2)				S24.40343	1
R	Cart. and plate ass'y 045 C.W. (P2) <i>Ins. cart. 045 oraria (P2)</i>	Pumpeneinheit 045 Rechtslauf (P2) <i>Conjunto cart. y platos 045 giro d. (P2)</i>	Cart. et plaque ass. 045 rot. d. (P2)				S24.40344	1
R	Cart. and plate ass'y 045 C.C.W. (P2) <i>Ins. cart. 045 antioraria (P2)</i>	Pumpeneinheit 045 Linkslauf (P2) <i>Conjunto cart. y platos 045 giro i. (P2)</i>	Cart. et plaque ass. 045 rot. g. (P2)				S24.40345	1
R	Cart. and plate ass'y 050 C.W. (P2) <i>Ins. cart. 050 oraria (P2)</i>	Pumpeneinheit 050 Rechtslauf (P2) <i>Conjunto cart. y platos 050 giro d. (P2)</i>	Cart. et plaque ass. 050 rot. d. (P2)				S24.40346	1
R	Cart. and plate ass'y 050 C.C.W. (P2) <i>Ins. cart. 050 antioraria (P2)</i>	Pumpeneinheit 050 Linkslauf (P2) <i>Conjunto cart. y platos 050 giro i. (P2)</i>	Cart. et plaque ass. 050 rot. g. (P2)				S24.40347	1
S	Cart. and plate ass'y B03 C.W. (P3) <i>Ins. cart. B03 oraria (P3)</i>	Pumpeneinheit B03 Rechtslauf (P3) <i>Conjunto cart. y platos B03 giro d. (P3)</i>	Cart. et plaque ass. B03 rot. d. (P3)				S24.40200	1
S	Cart. and plate ass'y B03 C.C.W. (P3) <i>Ins. cart. B03 antioraria (P3)</i>	Pumpeneinheit B03 Linkslauf (P3) <i>Conjunto cart. y platos B03 giro i. (P3)</i>	Cart. et plaque ass. B03 rot. g. (P3)				S24.40201	1
S	Cart. and plate ass'y B05 C.W. (P3) <i>Ins. cart. B05 oraria (P3)</i>	Pumpeneinheit B05 Rechtslauf (P3) <i>Conjunto cart. y platos B05 giro d. (P3)</i>	Cart. et plaque ass. B05 rot. d. (P3)				S24.40202	1
S	Cart. and plate ass'y B05 C.C.W. (P3) <i>Ins. cart. B05 antioraria (P3)</i>	Pumpeneinheit B05 Linkslauf (P3) <i>Conjunto cart. y platos B05 giro i. (P3)</i>	Cart. et plaque ass. B05 rot. g. (P3)				S24.40203	1
S	Cart. and plate ass'y B06 C.W. (P3) <i>Ins. cart. B06 oraria (P3)</i>	Pumpeneinheit B06 Rechtslauf (P3) <i>Conjunto cart. y platos B06 giro d. (P3)</i>	Cart. et plaque ass. B06 rot. d. (P3)				S24.40204	1
S	Cart. and plate ass'y B06 C.C.W. (P3) <i>Ins. cart. B06 antioraria (P3)</i>	Pumpeneinheit B06 Linkslauf (P3) <i>Conjunto cart. y platos B06 giro i. (P3)</i>	Cart. et plaque ass. B06 rot. g. (P3)				S24.40205	1
S	Cart. and plate ass'y B08 C.W. (P3) <i>Ins. cart. B08 oraria (P3)</i>	Pumpeneinheit B08 Rechtslauf (P3) <i>Conjunto cart. y platos B08 giro d. (P3)</i>	Cart. et plaque ass. B08 rot. d. (P3)				S24.40206	1
S	Cart. and plate ass'y B08 C.C.W. (P3) <i>Ins. cart. B08 antioraria (P3)</i>	Pumpeneinheit B08 Linkslauf (P3) <i>Conjunto cart. y platos B08 giro i. (P3)</i>	Cart. et plaque ass. B08 rot. g. (P3)				S24.40207	1
S	Cart. and plate ass'y B10 C.W. (P3) <i>Ins. cart. B10 oraria (P3)</i>	Pumpeneinheit B10 Rechtslauf (P3) <i>Conjunto cart. y platos B10 giro d. (P3)</i>	Cart. et plaque ass. B10 rot. d. (P3)				S24.40208	1
S	Cart. and plate ass'y B10 C.C.W. (P3) <i>Ins. cart. B10 antioraria (P3)</i>	Pumpeneinheit B10 Linkslauf (P3) <i>Conjunto cart. y platos B10 giro i. (P3)</i>	Cart. et plaque ass. B10 rot. g. (P3)				S24.40209	1
S	Cart. and plate ass'y B12 C.W. (P3) <i>Ins. cart. B12 oraria (P3)</i>	Pumpeneinheit B12 Rechtslauf (P3) <i>Conjunto cart. y platos B12 giro d. (P3)</i>	Cart. et plaque ass. B12 rot. d. (P3)				S24.40210	1
S	Cart. and plate ass'y B12 C.C.W. (P3) <i>Ins. cart. B12 antioraria (P3)</i>	Pumpeneinheit B12 Linkslauf (P3) <i>Conjunto cart. y platos B12 giro i. (P3)</i>	Cart. et plaque ass. B12 rot. g. (P3)				S24.40211	1
S	Cart. and plate ass'y B14 C.W. (P3) <i>Ins. cart. B14 oraria (P3)</i>	Pumpeneinheit B14 Rechtslauf (P3) <i>Conjunto cart. y platos B14 giro d. (P3)</i>	Cart. et plaque ass. B14 rot. d. (P3)				S24.40212	1

Item Pos. Réf. Pos. Pos.	Description <i>Descrizione</i>	Benennung <i>Descripcion</i>	Description		Part N° Teil Nr. Code N° Cod. N° Referencia T6EDC	Part N° Teil Nr. Code N° Cod. N° Referencia T6EDCM	Part N° Teil Nr. Code N° Cod. N° Referencia T6EDCS	Part N° Teil Nr. Code N° Cod. N° Referencia T6EDCR	Qty Stück Qté Q.tà Cant.
S	Cart. and plate ass'y B14 C.C.W. (P3) <i>Ins. cart. B14 antioraria (P3)</i>	Pumpeneinheit B14 Linkslauf (P3) <i>Conjunto cart. y platos B14 giro i. (P3)</i>	Cart. et plaque ass. B14 rot. g. (P3)					S24.40213	1
S	Cart. and plate ass'y B17 C.W. (P3) <i>Ins. cart. B17 oraria (P3)</i>	Pumpeneinheit B17 Rechtslauf (P3) <i>Conjunto cart. y platos B17 giro d. (P3)</i>	Cart. et plaque ass. B17 rot. d. (P3)					S24.40214	1
S	Cart. and plate ass'y B17 C.C.W. (P3) <i>Ins. cart. B17 antioraria (P3)</i>	Pumpeneinheit B17 Linkslauf (P3) <i>Conjunto cart. y platos B17 giro i. (P3)</i>	Cart. et plaque ass. B17 rot. g. (P3)					S24.40215	1
S	Cart. and plate ass'y B20 C.W. (P3) <i>Ins. cart. B20 oraria (P3)</i>	Pumpeneinheit B20 Rechtslauf (P3) <i>Conjunto cart. y platos B20 giro d. (P3)</i>	Cart. et plaque ass. B20 rot. d. (P3)					S24.40216	1
S	Cart. and plate ass'y B20 C.C.W. (P3) <i>Ins. cart. B20 antioraria (P3)</i>	Pumpeneinheit B20 Linkslauf (P3) <i>Conjunto cart. y platos B20 giro i. (P3)</i>	Cart. et plaque ass. B20 rot. g. (P3)					S24.40217	1
S	Cart. and plate ass'y B22 C.W. (P3) <i>Ins. cart. B22 oraria (P3)</i>	Pumpeneinheit B22 Rechtslauf (P3) <i>Conjunto cart. y platos B22 giro d. (P3)</i>	Cart. et plaque ass. B22 rot. d. (P3)					S24.40218	1
S	Cart. and plate ass'y B22 C.C.W. (P3) <i>Ins. cart. B22 antioraria (P3)</i>	Pumpeneinheit B22 Linkslauf (P3) <i>Conjunto cart. y platos B22 giro i. (P3)</i>	Cart. et plaque ass. B22 rot. g. (P3)					S24.40219	1
S	Cart. and plate ass'y B25 C.W. (P3) <i>Ins. cart. B25 oraria (P3)</i>	Pumpeneinheit B25 Rechtslauf (P3) <i>Conjunto cart. y platos B25 giro d. (P3)</i>	Cart. et plaque ass. B25 rot. d. (P3)					S24.40220	1
S	Cart. and plate ass'y B25 C.C.W. (P3) <i>Ins. cart. B25 antioraria (P3)</i>	Pumpeneinheit B25 Linkslauf (P3) <i>Conjunto cart. y platos B25 giro i. (P3)</i>	Cart. et plaque ass. B25 rot. g. (P3)					S24.40221	1
S	Cart. and plate ass'y B28 C.W. (P3) <i>Ins. cart. B28 oraria (P3)</i>	Pumpeneinheit B28 Rechtslauf (P3) <i>Conjunto cart. y platos B28 giro d. (P3)</i>	Cart. et plaque ass. B28 rot. d. (P3)					S24.40222	1
S	Cart. and plate ass'y B28 C.C.W. (P3) <i>Ins. cart. B28 antioraria (P3)</i>	Pumpeneinheit B28 Linkslauf (P3) <i>Conjunto cart. y platos B28 giro i. (P3)</i>	Cart. et plaque ass. B28 rot. g. (P3)					S24.40223	1
S	Cart. and plate ass'y B31 C.W. (P3) <i>Ins. cart. B31 oraria (P3)</i>	Pumpeneinheit B31 Rechtslauf (P3) <i>Conjunto cart. y platos B31 giro d. (P3)</i>	Cart. et plaque ass. B31 rot. d. (P3)					S24.45775	1
S	Cart. and plate ass'y B31 C.C.W. (P3) <i>Ins. cart. B31 antioraria (P3)</i>	Pumpeneinheit B31 Linkslauf (P3) <i>Conjunto cart. y platos B31 giro i. (P3)</i>	Cart. et plaque ass. B31 rot. g. (P3)					S24.45776	1
Notes									



## Model Code

## Typenschlüssel

## Désignation - type

Model number :

Typenbezeichnung :

Numéro du modèle :

T6EDC . - 062 - 035 - 017 - 1 R 00 - A 1 - P 0 - ..

Series

Baureihe

Série

One letter can be added to specify special parts in series

Optionen

Une lettre peut être ajoutée pour spécifier les pièces spéciales dans la série.

Cam ring for P1

(Volumetric displacement) (ml/rev.)

042 = 132,3

045 = 142,4

050 = 158,5

Hubring P1

(Geometrisches Fördervolumen) (cm<sup>3</sup>/U)

052 = 164,8

062 = 196,7

Came pour P1

(Cylindrée théorique) (cm<sup>3</sup>/tr)

066 = 213,3

072 = 227,1

Cam ring for P2

(Volumetric displacement) (ml/rev.)

014 = 47,6

017 = 58,2

020 = 66,0

024 = 79,5

Hubring P2

(Geometrisches Fördervolumen) (cm<sup>3</sup>/U)

028 = 89,7

031 = 98,3

035 = 111,0

038 = 120,3

Came pour P2

(Cylindrée théorique) (cm<sup>3</sup>/tr)

042 = 136,0

045 = 145,7

050 = 158,0

Cam ring for P3

(Volumetric displacement) (ml/rev.)

003 = 10,8

005 = 17,2

006 = 21,3

008 = 26,4

010 = 34,1

Hubring P3

(Geometrisches Fördervolumen) (cm<sup>3</sup>/U)

012 = 37,1

014 = 46,0

017 = 58,3

020 = 63,8

Came pour P3

(Cylindrée théorique) (cm<sup>3</sup>/tr)

022 = 70,3

025 = 79,3

028 = 88,8

031 = 100,0

Type of shaft

1 = keyed (G45N-ISO 3019-2)

Art der Welle

1 = Paßfederwelle (G45N-ISO 3019-2)

Type d'arbre

1 = à clavette (G45N-ISO 3019-2)

Direction of rotation

R = Clockwise

L = Counter-clockwise

Drehrichtung

R = Rechtslauf

L = Linkslauf

Sens de rotation

R = à droite

L = à gauche

Porting combination

00 = standard

Lage der Anschlüsse

0 = standard

Combinaison des orifices

00 = standard

Design letter

Ausführungsbuchstabe

Conception

Seal class

1 = S1 - BUNA N

4 = S4 - EPDM

5 = S5 - VITON

Dichtungsklasse

1 = S1 - BUNA N

4 = S4 - EPDM

5 = S5 - VITON

Classe de joint

1 = S1 - BUNA N

4 = S4 - EPDM

5 = S5 - VITON

Mounting (pump)

P = pedestal mounting

F = face mounting

Gehäuse (Pumpe)

P = Sockelmontage

F = Flanschmontage

Orifice (pompe)

P = montage pied

F = montage face

Mounting w/connection variables

0 P3 = 1" SAE size

1 P3 = 3/4" SAE size

Gehäuse-Anschlußgröße

0 P3 = 1" SAE

1 P3 = 3/4" SAE

Option sur orifices

0 P3 = 1" SAE

1 P3 = 3/4" SAE

Modifications

Modifikationen

Modifications



Model Code	Typenschlüssel	Désignation - type
<b>Model number :</b>	<b>Typenbezeichnung :</b>	<b>Numéro du modèle :</b> T6EDCM . - 062 - B35 - B17 - 1 R 00 - A 1 - P 0 - ..
<b>Series</b> _____	<b>Baureihe</b> _____	<b>Série</b> _____
One letter can be added to specify special parts in series _____	Optionen _____	Une lettre peut être ajoutée pour spécifier les pièces spéciales dans la série. _____
<b>Cam ring for P1</b> _____ (Volumetric displacement) (ml/rev.) 042 = 132,3 045 = 142,4 050 = 158,5	<b>Hubring P1</b> _____ (Geometrisches Fördervolumen) (cm <sup>3</sup> /U) 052 = 164,8 062 = 196,7	<b>Came pour P1</b> _____ (Cylindrée théorique) (cm <sup>3</sup> /tr) 066 = 213,3 072 = 227,1
<b>Cam ring for P2</b> _____ (Volumetric displacement) (ml/rev.) B14 = 47,6 B17 = 58,2 B20 = 66,0 B24 = 79,5	<b>Hubring P2</b> _____ (Geometrisches Fördervolumen) (cm <sup>3</sup> /U) B28 = 89,7 B31 = 98,3 B35 = 111,0 B38 = 120,3	<b>Came pour P2</b> _____ (Cylindrée théorique) (cm <sup>3</sup> /tr) B42 = 136,0 B45 = 145,7 B50 = 158,0
<b>Cam ring for P3</b> _____ (Volumetric displacement) (ml/rev.) B03 = 10,8 B05 = 17,2 B06 = 21,3 B08 = 26,4 B10 = 34,1	<b>Hubring P3</b> _____ (Geometrisches Fördervolumen) (cm <sup>3</sup> /U) B12 = 37,1 B14 = 46,0 B17 = 58,3 B20 = 63,8	<b>Came pour P3</b> _____ (Cylindrée théorique) (cm <sup>3</sup> /tr) B22 = 70,3 B25 = 79,3 B28 = 88,8 B31 = 100,0
<b>Type of shaft</b> _____ 1 = keyed (G45N-ISO 3019-2) 3 = splined (SAE D & E)	<b>Art der Welle</b> _____ 1 = Paßfederwelle (G45N-ISO 3019-2) 3 = Vielkeilwelle (SAE D & E)	<b>Type d'arbre</b> _____ 1 = à clavette (G45N-ISO 3019-2) 3 = à cannelures (SAE D & E)
<b>Direction of rotation</b> _____ R = Clockwise L = Counter-clockwise	<b>Drehrichtung</b> _____ R = Rechtslauf L = Linkslauf	<b>Sens de rotation</b> _____ R = à droite L = à gauche
<b>Porting combination</b> _____ 00 = standard	<b>Lage der Anschlüsse</b> _____ 0 = standard	<b>Combinaison des orifices</b> _____ 00 = standard
<b>Design letter</b> _____	<b>Ausführungsbuchstabe</b> _____	<b>Conception</b> _____
<b>Seal class</b> _____ 1 = S1 - BUNA N 4 = S4 - EPDM 5 = S5 - VITON	<b>Dichtungsklasse</b> _____ 1 = S1 - BUNA N 4 = S4 - EPDM 5 = S5 - VITON	<b>Classe de joint</b> _____ 1 = S1 - BUNA N 4 = S4 - EPDM 5 = S5 - VITON
<b>Mounting (pump)</b> _____ P = pedestal mounting F = face mounting	<b>Gehäuse (Pumpe)</b> _____ P = Sockelmontage F = Flanschmontage	<b>Orifice (pompe)</b> _____ P = montage pied F = montage face
<b>Mounting w/connection variables</b> _____ 0 P3 = 1" SAE size 1 P3 = 3/4" SAE size	<b>Gehäuse-Anschlußgröße</b> _____ 0 P3 = 1" SAE 1 P3 = 3/4" SAE	<b>Option sur orifices</b> _____ 0 P3 = 1" SAE 1 P3 = 3/4" SAE
<b>Modifications</b> _____	<b>Modifikationen</b> _____	<b>Modifications</b> _____

## Designazione

## Clave de designación

**Sigla :**

**Referencia modelo :**

**T6EDCM . - 062 - B35 - B17 - 1 R 00 - A 1 - P 0 - ..**

**Serie** \_\_\_\_\_

**Serie** \_\_\_\_\_

Una lettera può essere aggiunta per specificare parti speciali nella serie

Una letra puede ser añadida para especificar piezas especiales en la serie

**Tipo di cartuccia P1**

(Cylindrata) (ml/giro)

042 = 132,3

045 = 142,4

050 = 158,5

052 = 164,8

**Aro volumetrico para P1**

(Cilindrada) (ml/rev)

062 = 196,7

066 = 213,3

072 = 227,1

**Tipo di cartuccia P2**

(Cylindrata) (ml/giro)

B14 = 47,6

B17 = 58,2

B20 = 66,0

B24 = 79,5

B28 = 89,7

B31 = 98,3

**Aro volumetrico para P2**

(Cilindrada) (ml/rev)

B35 = 111,0

B38 = 120,3

B42 = 136,0

B45 = 145,7

B50 = 158,0

**Tipo di cartuccia P3**

(Cylindrata) (ml/giro)

B03 = 10,8

B05 = 17,2

B06 = 21,3

B08 = 26,4

B10 = 34,1

B12 = 37,1

B14 = 46,0

**Aro volumetrico para P3**

(Cilindrada) (ml/rev)

B17 = 58,3

B20 = 63,8

B22 = 70,3

B25 = 79,3

B28 = 88,8

B31 = 100,0

**Tipo di albero**

1 = a chiavetta (G45N-ISO 3019-2)

3 = scanalato (SAE D & E)

**Tipo de eje**

1 = chaveteado (G45N-ISO 3019-2)

3 = estriado (SAE D & E)

**Senso di rotazione**

R =orario

L = Antiorario

**Sentido de giro**

R = Derecha

L = Izquierda

**Orientamento delle bocche**

00 = standard

**Posición de bocas**

00 = estándar

**Disegno**

**Letra de diseño**

**Tipo di guarnizioni**

1 = S1 - BUNA N

4 = S4 - EPDM

5 = S5 - VITON

**Clase de juntas**

1 = S1 - BUNA N

4 = S4 - EPDM

5 = S5 - VITON

**Montaggio (pompa)**

P = piedestallo

F = battuta

**Montaje bomba**

P =

F =

**Dimensioni delle bocche**

0 P3 = 1" SAE

1 P3 = 3/4" SAE

**Conexiones de montaje**

0 P3 = 1" SAE

1 P3 = 3/4" SAE

**Modifiche**

**Modificaciones**

**Model Code****Typenschlüssel****Désignation - type****Model number :****Typenbezeichnung :****Numéro du modèle :****T6EDCS . - 062 - B35 - B17 - 3 R 00 - A 1 - P 0 - ..****Series****Baureihe****Série**

One letter can be added to specify special parts in series

Optionen

Une lettre peut être ajoutée pour spécifier les pièces spéciales dans la série.

**Cam ring for P1**

(Volumetric displacement) (ml/rev.)

042 = 132,3

045 = 142,4

050 = 158,5

**Hubring P1**(Geometrisches Fördervolumen) (cm<sup>3</sup>/U)

052 = 164,8

062 = 196,7

**Came pour P1**(Cylindrée théorique) (cm<sup>3</sup>/tr)

066 = 213,3

072 = 227,1

**Cam ring for P2**

(Volumetric displacement) (ml/rev.)

B14 = 47,6

B17 = 58,2

B20 = 66,0

B24 = 79,5

**Hubring P2**(Geometrisches Fördervolumen) (cm<sup>3</sup>/U)

B28 = 89,7

B31 = 98,3

B35 = 111,0

B38 = 120,3

**Came pour P2**(Cylindrée théorique) (cm<sup>3</sup>/tr)

B42 = 136,0

B45 = 145,7

B50 = 158,0

**Cam ring for P3**

(Volumetric displacement) (ml/rev.)

B03 = 10,8

B05 = 17,2

B06 = 21,3

B08 = 26,4

B10 = 34,1

**Hubring P3**(Geometrisches Fördervolumen) (cm<sup>3</sup>/U)

B12 = 37,1

B14 = 46,0

B17 = 58,3

B20 = 63,8

**Came pour P3**(Cylindrée théorique) (cm<sup>3</sup>/tr)

B22 = 70,3

B25 = 79,3

B28 = 88,8

B31 = 100,0

**Type of shaft**

2 = keyed (SAE D &amp; E)

3 = splined (SAE D &amp; E)

**Art der Welle**

2 = Paßfederwelle (SAE D &amp; E)

3 = Vielkeilwelle (SAE D &amp; E)

**Type d'arbre**

2 = à clavette (SAE D &amp; E)

3 = à cannelures (SAE D &amp; E)

**Direction of rotation**

R = Clockwise

L = Counter-clockwise

**Drehrichtung**

R = Rechtslauf

L = Linkslauf

**Sens de rotation**

R = à droite

L = à gauche

**Porting combination**

00 = standard

**Lage der Anschlüsse**

0 = standard

**Combinaison des orifices**

00 = standard

**Design letter****Ausführungsbuchstabe****Conception****Seal class**

1 = S1 - BUNA N

4 = S4 - EPDM

5 = S5 - VITON

**Dichtungsklasse**

1 = S1 - BUNA N

4 = S4 - EPDM

5 = S5 - VITON

**Classe de joint**

1 = S1 - BUNA N

4 = S4 - EPDM

5 = S5 - VITON

**Mounting (pump)**

P = pedestal mounting

F = face mounting

**Gehäuse (Pumpe)**

P = Sockelmontage

F = Flanschmontage

**Orifice (pompe)**

P = montage pied

F = montage face

**Mounting w/connection variables**

0 P3 = 1" SAE size

1 P3 = 3/4" SAE size

**Gehäuse-Anschlußgröße**

0 P3 = 1" SAE

1 P3 = 3/4" SAE

**Option sur orifices**

0 P3 = 1" SAE

1 P3 = 3/4" SAE

**Modifications****Modifikationen****Modifications**

## Designazione

## Clave de designación

### Sigla :

### Referencia modelo :

**T6EDCS . - 062 - B35 - B17 - 3 R 00 - A 1 - P 0 - ..**

Serie \_\_\_\_\_

Serie \_\_\_\_\_

Una lettera può essere aggiunta per specificare parti speciali nella serie

Una letra puede ser añadida para especificar piezas especiales en la serie

### Tipo di cartuccia P1

(Cylindrata) (ml/giro)

042 = 132,3

045 = 142,4

050 = 158,5

052 = 164,8

### Aro volumetrico para P1

(Cilindrada) (ml/rev)

062 = 196,7

066 = 213,3

072 = 227,1

### Tipo di cartuccia P2

(Cylindrata) (ml/giro)

B14 = 47,6

B17 = 58,2

B20 = 66,0

B24 = 79,5

B28 = 89,7

B31 = 98,3

### Aro volumetrico para P2

(Cilindrada) (ml/rev)

B35 = 111,0

B38 = 120,3

B42 = 136,0

B45 = 145,7

B50 = 158,0

### Tipo di cartuccia P3

(Cylindrata) (ml/giro)

B03 = 10,8

B05 = 17,2

B06 = 21,3

B08 = 26,4

B10 = 34,1

B12 = 37,1

B14 = 46,0

### Aro volumetrico para P3

(Cilindrada) (ml/rev)

B17 = 58,3

B20 = 63,8

B22 = 70,3

B25 = 79,3

B28 = 88,8

B31 = 100,0

### Tipo di albero

2 = a chiavetta (SAE D & E)

3 = scanalato (SAE D & E)

### Tipo de eje

2 = chaveteado (SAE D & E)

3 = estriado (SAE D & E)

### Senso di rotazione

R =orario

L = Antiorario

### Sentido de giro

R = Derecha

L = Izquierda

### Orientamento delle bocche

00 = standard

### Posición de bocas

00 = estándar

### Disegno

### Letra de diseño

### Tipo di guarnizioni

1 = S1 - BUNA N

4 = S4 - EPDM

5 = S5 - VITON

### Clase de juntas

1 = S1 - BUNA N

4 = S4 - EPDM

5 = S5 - VITON

### Montaggio (pompa)

P = piedestallo

F = battuta

### Montaje bomba

P =

F =

### Dimensioni delle bocche

0 P3 = 1" SAE

1 P3 = 3/4" SAE

### Conexiones de montaje

0 P3 = 1" SAE

1 P3 = 3/4" SAE

### Modifiche

### Modificaciones

## Model Code

## Typenschlüssel

## Désignation - type

Model number :

Typenbezeichnung :

Numéro du modèle :

T6EDC R . - 062 - \*35 - \*17 - 1 R 00 - A 1 - P 0 - ..

Series

Baureihe

Série

Rear cap end for mounting SAE A auxiliary pump  
coupling adaptor SAE A 9 teeth

Endkappe zur Montage einer SAE A Zusatzpumpe,  
Kupplungsadapter SAE A - 9 Zähne

Chapeau arrière pour montage pompe auxiliaire SAE A  
Adapteur SAE A - 9 dents

One letter can be added to specify special parts in  
series

Optionen

Une lettre peut être ajoutée pour spécifier les pièces  
spéciales dans la série.

Cam ring for P1

(Volumetric displacement) (ml/rev.)

042 = 132,3  
045 = 142,4  
050 = 158,5

Hubring P1

(Geometrisches Fördervolumen) (cm<sup>3</sup>/U)

052 = 164,8  
062 = 196,7

Came pour P1

(Cylindrée théorique) (cm<sup>3</sup>/tr)

066 = 213,3  
072 = 227,1

Cam ring for P2

(Volumetric displacement) (ml/rev.)

\*14 = 47,6  
\*17 = 58,2  
\*20 = 66,0  
\*24 = 79,5

Hubring P2

(Geometrisches Fördervolumen) (cm<sup>3</sup>/U)

\*28 = 89,7  
\*31 = 98,3  
\*35 = 111,0  
\*38 = 120,3

Came pour P2

(Cylindrée théorique) (cm<sup>3</sup>/tr)

\*42 = 136,0  
\*45 = 145,7  
\*50 = 158,0

Cam ring for P3

(Volumetric displacement) (ml/rev.)

\*03 = 10,8  
\*05 = 17,2  
\*06 = 21,3  
\*08 = 26,4  
\*10 = 34,1

Hubring P3

(Geometrisches Fördervolumen) (cm<sup>3</sup>/U)

\*12 = 37,1  
\*14 = 46,0  
\*17 = 58,3  
\*20 = 63,8

Came pour P3

(Cylindrée théorique) (cm<sup>3</sup>/tr)

\*22 = 70,3  
\*25 = 79,3  
\*28 = 88,8  
\*31 = 100,0

Type of shaft

1 = keyed (G45N-ISO 3019-2)  
3 = splined (SAE D & E)

Art der Welle

1 = Paßfederwelle (G45N-ISO 3019-2)  
3 = Vielkeilwelle (SAE D & E)

Type d'arbre

1 = à clavette (G45N-ISO 3019-2)  
3 = à cannelures (SAE D & E)

Direction of rotation

R = Clockwise  
L = Counter-clockwise

Drehrichtung

R = Rechtslauf  
L = Linkslauf

Sens de rotation

R = à droite  
L = à gauche

Porting combination

00 = standard

Lage der Anschlüsse

0 = standard

Combinaison des orifices

00 = standard

Design letter

Ausführungsbuchstabe

Conception

Seal class

1 = S1 - BUNA N  
4 = S4 - EPDM  
5 = S5 - VITON

Dichtungsklasse

1 = S1 - BUNA N  
4 = S4 - EPDM  
5 = S5 - VITON

Classe de joint

1 = S1 - BUNA N  
4 = S4 - EPDM  
5 = S5 - VITON

Mounting (pump)

P = pedestal mounting  
F = face mounting

Gehäuse (Pumpe)

P = Sockelmontage  
F = Flanschmontage

Orifice (pompe)

P = montage pied  
F = montage face

Mounting w/connection variables

0 P3 = 1" SAE size  
1 P3 = 3/4" SAE size

Gehäuse-Anschlußgröße

0 P3 = 1" SAE  
1 P3 = 3/4" SAE

Option sur orifices

0 P3 = 1" SAE  
1 P3 = 3/4" SAE

Modifications

Modifikationen

Modifications

# esignazione

# Clave de designación

<b>Sigla :</b>	<b>Referencia modelo :</b>	<b>T6EDC R . - 062 - *35 - *17 - 1 R 00 - A 1 - P 0 - ..</b>	
<b>Serie</b> _____	<b>Serie</b> _____		
Coperchio posteriore per giunto di accoppiamento alla pompa ausiliaria SAE A - 9 denti _____			
Una lettera può essere aggiunta per specificare parti speciali nella serie _____	Una letra puede ser añadida para especificar piezas especiales en la serie _____		
<b>Tipo di cartuccia P1</b> _____ (Cilindrata) (ml/giro) 042 = 132,3 045 = 142,4 050 = 158,5 052 = 164,8	<b>Aro volumetrico para P1</b> _____ (Cilindrada) (ml/rev) 062 = 196,7 066 = 213,3 072 = 227,1		
<b>Tipo di cartuccia P2</b> _____ (Cilindrata) (ml/giro) 014 = 47,6      028 = 89,7 017 = 58,2      031 = 98,3 020 = 66,0      035 = 111,0 024 = 79,5      038 = 120,3	<b>Aro volumetrico para P2</b> _____ (Cilindrada) (ml/rev) 042 = 136,0 045 = 145,7 050 = 158,0		
<b>Tipo di cartuccia P3</b> _____ (Cilindrata) (ml/giro) 003 = 10,8      012 = 37,1 005 = 17,2      014 = 46,0 006 = 21,3      017 = 58,3 008 = 26,4      020 = 63,8 010 = 34,1	<b>Aro volumetrico para P3</b> _____ (Cilindrada) (ml/rev) 022 = 70,3 025 = 79,3 028 = 88,8 031 = 100,0		
<b>Tipo di albero</b> _____ 1 = a chivetta (G45N-ISO 3019-2) 3 = scanalato (SAE D & E)	<b>Tipo de eje</b> _____ 1 = chaveteado (G45N-ISO 3019-2) 3 = estriado (SAE D & E)		
<b>Senso di rotazione</b> _____ R = Orario L = Antiorario	<b>Sentido de giro</b> _____ R = Derecha L = Izquierda		
<b>Orientamento delle bocche</b> _____ 00 = standard	<b>Posición de bocas</b> _____ 00 = estándar		
<b>Disegno</b> _____	<b>Letra de diseño</b> _____		
<b>Tipo di guarnizioni</b> _____ 1 = S1 - BUNA N 4 = S4 - EPDM 5 = S5 - VITON	<b>Clase de juntas</b> _____ 1 = S1 - BUNA N 4 = S4 - EPDM 5 = S5 - VITON		
<b>Montaggio (pompa)</b> _____ P = piedestallo F = battuta	<b>Montaje bomba</b> _____ P = F =		
<b>Dimensioni delle bocche</b> _____ 0 P3 = 1" SAE 1 P3 = 3/4" SAE	<b>Conexiones de montaje</b> _____ 0 P3 = 1" SAE 1 P3 = 3/4" SAE		
<b>Modifiche</b> _____	<b>Modificaciones</b> _____		
* = 0 = Unirotagonale * = B = Birotagonale	* = 0 = Uni-direccional * = B = Bi-direccional		