



Vane pumps

Service information

vane-type triple pump / Flügelzellen-Dreifachpumpe

pompe triple à palettes / pompa tripla a palette

tipo bomba de paletas triple

T6DCC - T6DCCM

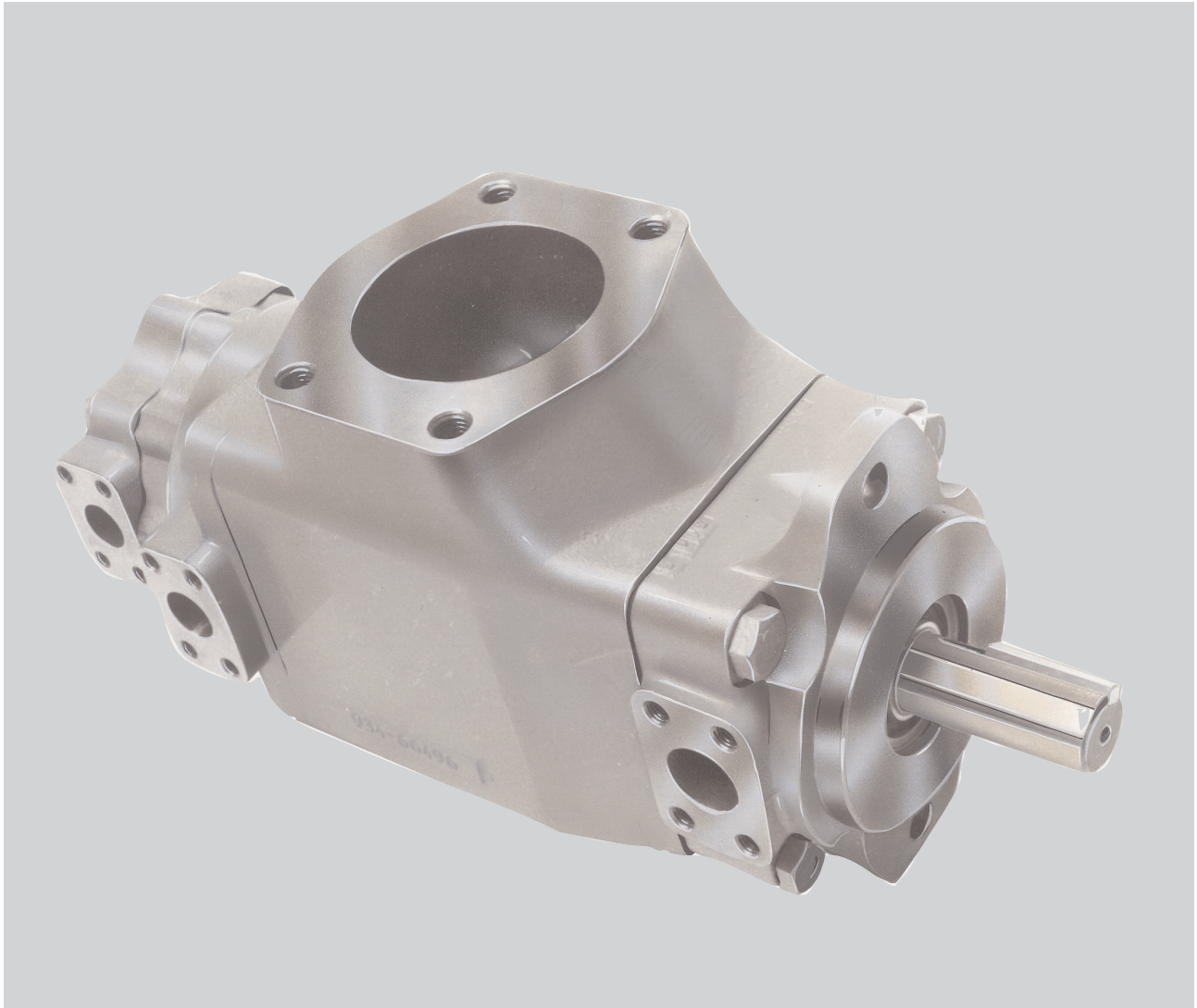

Publ. S1 - ML0510 - C

09 / 2002 / FB

Replaces : S1 - ML0510 - B

L25 - 10510 - 3

DENISON | Hydraulics

Recommended repair kits and assy's are bold printed
 Empfohlene Austausch - Baugruppen sind fett gedruckt
 Les pochettes de rechange recommandées sont imprimées en caractères gras
 I kit di ricambio consigliati sono indicati in grassetto
 Los juegos de reparacion recomendados y los conjuntos, estan en negrita

	Item - Pos. - Réf. - Pos.		
	42	43	46
Mounting torque			
Anziehdrehmoment	68 Nm	187 Nm	187 Nm
Couple de serrage	50 ft.lbs	138 ft.lbs	138 ft.lbs
Coppia di serraggio			
Par de apriete			

T6DCC

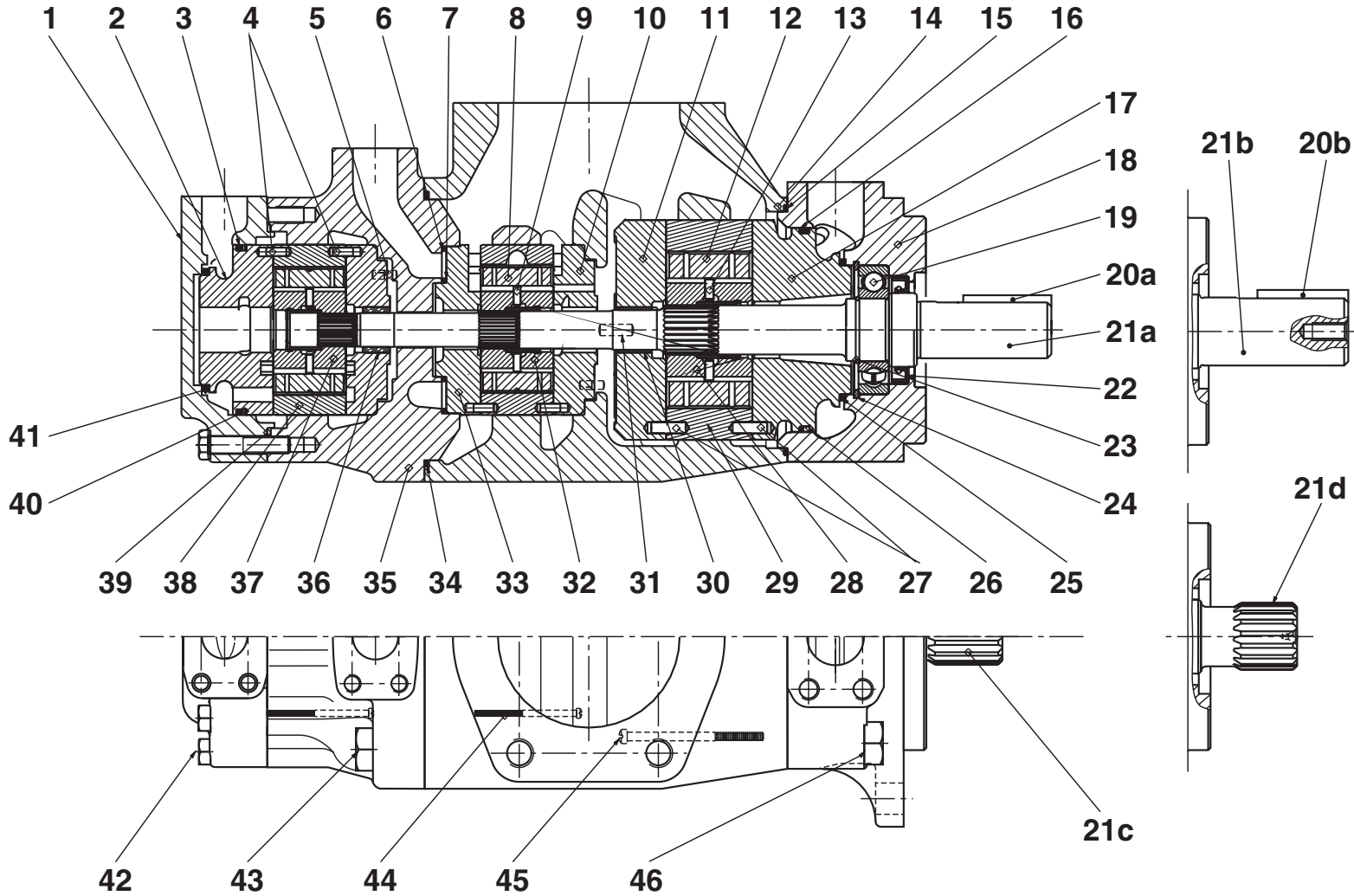

Recommended repair kits and assy's are bolt printed
 Empfohlene Austausch - Baugruppen sind fett gedruckt
 Les pochettes de rechange recommandées sont imprimées en caractères gras
 I kit di ricambio consigliati sono indicati in grassetto
 Los juegos de reparacion recomendados y los conjuntos, estan en negrita

	Item - Pos. - Réf. - Pos.		
	42	43	46
Mounting torque			
Anziehdrehmoment	68 Nm	187 Nm	187 Nm
Couple de serrage	50 ft.lbs	138 ft.lbs	138 ft.lbs
Coppia di serragio			
Par de apriete			

T6DCCM

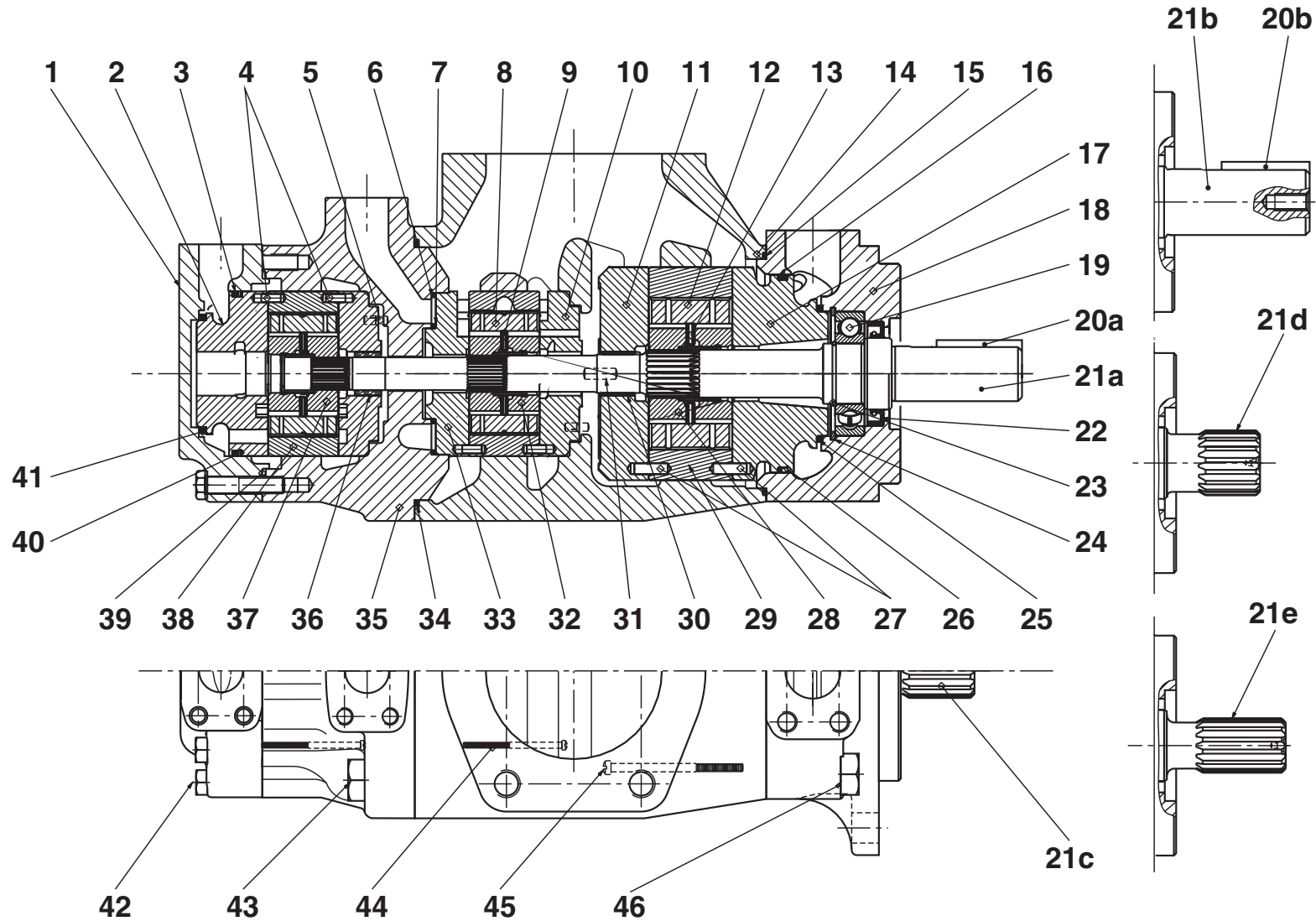

Item Pos. Ref. Pos. Pos.	Description Descrizione	Benennung Descripción	Description		Part N° Teil Nr. Code N° Cod. N° Referencia T6DCC	Part N° Teil Nr. Code N° Cod. N° Referencia T6DCCM	Qty Stück Qté Q.tà Cant.
1	End cap (P3 = 3/4") UNC <i>Coperchio (P3 = 3/4") UNC</i>	Deckel (P3 = 3/4") UNC <i>Tapa (P3 = 3/4") UNC</i>	Chapeau (P3 = 3/4") UNC		034.66523		1
	End cap (P3 = 1") UNC <i>Coperchio (P3 = 1") UNC</i>	Deckel (P3 = 1") UNC <i>Tapa (P3 = 1") UNC</i>	Chapeau (P3 = 1") UNC		034.48579		1
	End cap (P3 = 3/4") metric <i>Coperchio (P3 = 3/4") metrica</i>	Deckel (P3 = 3/4") Metrisch <i>Tapa (P3 = 3/4") metrico</i>	Chapeau (P3 = 3/4") métrique		034.66765		1
	End cap (P3 = 1") metric <i>Coperchio (P3 = 1") metrica</i>	Deckel (P3 = 1") Metrisch <i>Tapa (P3 = 1") metrico</i>	Chapeau (P3 = 1") métrique		034.71327		1
2	Port plate-pressure C.C.W. <i>Piatto distributore anter. antioraria</i>	Steuerplatte Linkslauf <i>Plato distribuidor-presión giro I</i>	Plaque pression rotation gauche	C	034.59772		1
	Port plate-pressure C.W. <i>Piatto distributore anter. oraria</i>	Steuerplatte Rechtslauf <i>Plato distribuidor-presión giro D</i>	Plaque pression rotation droite	C	034.59773		1
	Port plate-pressure <i>Piatto distributore anter.</i>	Steuerplatte <i>Plato distribuidor-presión</i>	Plaque pression	C		034.66453	1
3	Sq. section seal <i>Guarnizione</i>	Dichtring <i>Junta seccion cuadrada</i>	Joint section carrée	CD	691.10238		1
4	Dowel pin <i>Spina</i>	Zentrierstift <i>Pasador</i>	Goupille	BC	324.21208		4
5	Dowel pin <i>Spina</i>	Zentrierstift <i>Pasador</i>	Goupille	BC N...U	323.82010		2
6	Sq. section seal <i>Guarnizione</i>	Dichtring <i>Junta seccion cuadrada</i>	Joint section carrée	BD	691.10153		1
7	Sq. section seal <i>Guarnizione</i>	Dichtring <i>Junta seccion cuadrada</i>	Joint section carrée	BD	691.10137		1
8	Vane <i>Paletta</i>	Flügel <i>Paleta</i>	Palette	BC	034.59099	034.66716	20
9	Pin-vane holdout <i>Pistoncino di sostentamento</i>	Stößel <i>Espiga empuje paleta</i>	Poussoir de palette	BC	034.59098	034.24982	20
10	Port plate-rear C.C.W. <i>Piatto distributore post. antioraria</i>	Steuerplatte Linkslauf <i>Plato distribuidor trasero giro I</i>	Plaque arrière rotation gauche	BC NS	034.59776		2
	Port plate-rear C.W. <i>Piatto distributore post. oraria</i>	Steuerplatte Rechtslauf <i>Plato distribuidor trasero giro D</i>	Plaque arrière rotation droite	BC PT	034.59777		2
	Port plate-rear <i>Piatto distributore post.</i>	Steuerplatte <i>Plato distribuidor trasero</i>	Plaque arrière	BC RU		034.59118	1
11	Port plate-rear C.C.W. <i>Piatto distributore post. antioraria</i>	Steuerplatte Linkslauf <i>Plato distribuidor trasero giro I</i>	Plaque arrière rotation gauche	AK	034.67114		1
	Port plate-rear C.W. <i>Piatto distributore post. oraria</i>	Steuerplatte Rechtslauf <i>Plato distribuidor trasero giro D</i>	Plaque arrière rotation droite	AL	034.67112		1
	Port plate-rear <i>Piatto distributore post.</i>	Steuerplatte <i>Plato distribuidor trasero</i>	Plaque arrière	AM		034.59101	1
12	Vane <i>Paletta</i>	Flügel <i>Paleta</i>	Palette	A	034.53588		10
13	Pin-vane holdout <i>Pistoncino di sostentamento</i>	Stößel <i>Espiga empuje paleta</i>	Poussoir de palette	A	034.59130	034.24984	10
14	Housing UNC <i>Corpo UNC</i>	Gehäuse UNC <i>Cuerpo UNC</i>	Carter UNC		034.66497		1
	Housing metric <i>Corpo metrica</i>	Gehäuse Metrisch <i>Cuerpo metrico</i>	Carter métrique		034.66763		1
15	Sq. section seal <i>Guarnizione</i>	Dichtring <i>Junta seccion cuadrada</i>	Joint section carrée	AD	671.10159		1

Item Pos. Réf. Pos. Pos.	Description Descrizione	Benennung Descripción	Description		Part N° Teil Nr. Code N° Cod. N° Referencia T6DCC	Part N° Teil Nr. Code N° Cod. N° Referencia T6DCCM	Qty Stück Qté Q.tà Cant.
16	Back-up ring <i>Anello anti-estrusione</i>	Stützring <i>Anillo</i>	Bague anti-extrusion	AD	618.00011.3		1
17	Port plate-pressure C.C.W <i>Piatto distributore anter. antioraria</i>	Steuerplatte Linkslauf <i>Plato distribuidor-presión giro I</i>	Plaque pression rotation gauche	A	034.67113		1
	Port plate-pressure C.W. <i>Piatto distributore anter. oraria</i>	Steuerplatte Rechtslauf <i>Plato distribuidor-presión giro D</i>	Plaque pression rotation droite	A	034.67111		1
	Port plate-pressure <i>Piatto distributore anter.</i>	Steuerplatte <i>Plato distribuidor-presión</i>	Plaque pression	A		034.59057	1
	Mounting cap UNC <i>Coperchio anteriore UNC</i>	Deckel UNC <i>Tapa de montage UNC</i>	Chapeau de montage UNC		034.66495		1
Mounting cap metric <i>Coperchio anteriore metrica</i>	Deckel Metrisch <i>Tapa de montage metrica</i>	Chapeau de montage métrique		034.66748		1	
19	Ball bearing <i>Cuscinetto a sfere</i>	Kugellager <i>Cojinete de bolas</i>	Roulement à billes	EF GHJ	230.00207		1
20a	Key (code 1) <i>Chiavetta (codice 1)</i>	Paßfeder (Typ 1) <i>Chaveta (codigo 1)</i>	Clavette (code 1)	E	034.19579		1
20b	Key (code 2) <i>Chiavetta (codice 2)</i>	Paßfeder (Typ 2) <i>Chaveta (codigo 2)</i>	Clavette (code 2)	F	034.66981		1
21a	Shaft (keyed) (code1) <i>Albero a chiavetta (codice 1)</i>	Welle für Paßfeder (Typ 1) <i>Eje chaveteado (codigo 1)</i>	Arbre à clavette (code 1)	E	034.66500		1
21b	Shaft (keyed) (code 2) <i>Albero a chiavetta (codice 2)</i>	Welle für Paßfeder (Typ 2) <i>Eje chaveteado (codigo 2)</i>	Arbre à clavette (code 2)	F	034.66513		1
21c	Shaft (splined) (code 3) <i>Albero a scanalato (codice 3)</i>	Vielkeilwelle (Typ 3) <i>Eje estriado (codigo 3)</i>	Arbre à cannelures (code 3)	G	034.66511		1
21d	Shaft (splined) (code 4) <i>Albero scanalato (codice 4)</i>	Vielkeilwelle (Typ 4) <i>Eje estriado (codigo 4)</i>	Arbre à cannelures (code 4)	H	034.66514		1
21e	Shaft (splined) (code 6) <i>Albero scanalato (codice 6)</i>	Vielkeilwelle (Typ 6) <i>Eje estriado (codigo 6)</i>	Arbre à cannelures (code T)	J		034.66733	1
22	Shaft seal (S1 - 0,7 bar) <i>Paraolio (S1 - 0,7 bar)</i>	Simmerring (S1 - 0,7 bar) <i>Reten eje (S1 - 0,7 bar)</i>	Joint d'arbre (S1 - 0,7 bar)	D	620.82064		1
	Shaft seal (S4 - S5 - 7 bar) <i>Paraolio (S4 - S5 - 7 bar)</i>	Simmerring (S4 - S5 - 7 bar) <i>Reten eje (S4 - S5 - 7 bar)</i>	Joint d'arbre (S4 - S5 - 7 bar)	D	620.82072		1
23	Round section ring <i>Anello elastico</i>	Sicherungsring <i>Anillo tórico</i>	Anneau	EF GHJ	034.70853		1
24	Retaining ring <i>Anello elastico</i>	Sicherungsring <i>Anillo de retención</i>	Circlips		356.32283		1
25	Sq. section seal <i>Guarnizione</i>	Dichtring <i>Junta seccion cuadrada</i>	Joint section carrée	AD	691.10232		1
26	Sq. section seal <i>Guarnizione</i>	Dichtring <i>Junta seccion cuadrada</i>	Joint section carrée	A	691.10244		1
27	Dowel pin <i>Spina</i>	Zentrierstift <i>Pasador</i>	Goupille	A	324.21612		2
28	Rotor-insert ass'y <i>Insieme rotore</i>	Rotor <i>Conjunto rotor</i>	Rotor et douille ass.	A	S24.10121	S24.30018	1
29	Cam ring 014 <i>Anello camma 014</i>	Hubring 014 <i>Aro volumetrico 014</i>	Came 014	A	034.66708		1
	Cam ring 017 <i>Anello camma 017</i>	Hubring 017 <i>Aro volumetrico 017</i>	Came 017	A	034.67028		1
	Cam ring 020 <i>Anello camma 020</i>	Hubring 020 <i>Aro volumetrico 020</i>	Came 020	A	034.66596		1

Item Pos. Réf. Pos. Pos.	Description Descrizione	Benennung Descripción	Description		Part N° Teil Nr. Code N° Cod. N° Referencia T6DCC	Part N° Teil Nr. Code N° Cod. N° Referencia T6DCCM	Qty Stück Qté Q.tà Cant.	
29	Cam ring 024 <i>Anello camma 024</i>	Hubring 024 <i>Aro volumetrico 024</i>	Came 024	A	034.59294		1	
	Cam ring 028 <i>Anello camma 028</i>	Hubring 028 <i>Aro volumetrico 028</i>	Came 028	A	034.59133		1	
	Cam ring 031 <i>Anello camma 031</i>	Hubring 031 <i>Aro volumetrico 031</i>	Came 031	A	034.59135		1	
	Cam ring 035 <i>Anello camma 035</i>	Hubring 035 <i>Aro volumetrico 035</i>	Came 035	A	034.59137		1	
	Cam ring 038 <i>Anello camma 038</i>	Hubring 038 <i>Aro volumetrico 038</i>	Came 038	A	034.59139		1	
	Cam ring 042 <i>Anello camma 042</i>	Hubring 042 <i>Aro volumetrico 042</i>	Came 042	A	034.59132		1	
	Cam ring 045 <i>Anello camma 045</i>	Hubring 045 <i>Aro volumetrico 045</i>	Came 045	A	034.59131		1	
	Cam ring 050 <i>Anello camma 050</i>	Hubring 050 <i>Aro volumetrico 050</i>	Came 050	A	034.66737		1	
	30	Bush <i>Bussola</i>	Buchse <i>Cojinete de fricción</i>	Bague	ALM	034.70868		1
	31	Dowel pin <i>Spina</i>	Zentrierstift <i>Pasador</i>	Goupille	ALM	323.82004		1
32	Rotor-insert ass'y <i>Insieme rotore</i>	Rotor <i>Conjunto rotor</i>	Rotor et douille ass.	B	S24.10350	S24.33974	1	
33	Port plate-pressure C.C.W. <i>Piatto distributore anter.antioraria</i>	Steuerplatte Linkslauf <i>Plato distribuidor-presión giro I</i>	Plaque pression rotation gauche	B	034.66522		1	
	Port plate-pressure C.W. <i>Piatto distributore anter. oraria</i>	Steuerplatte Rechtslauf <i>Plato distribuidor-presión giro D</i>	Plaque pression rotation droite	B	034.66521		1	
	Port plate-pressure <i>Piatto distributore anter.</i>	Steuerplatte <i>Plato distribuidor-presión</i>	Plaque pression	B		034.66493	1	
34	Sq. section seal <i>Guarnizione</i>	Dichtring <i>Junta seccion cuadrada</i>	Joint section carrée	BD	691.10256		1	
35	Port block UNC <i>Coperchio intermedio UNC</i>	Anschlußblock UNC <i>Bloque distribuidor UNC</i>	Palier UNC		034.66499		1	
	Port block metric <i>Coperchio intermedio metrica</i>	Anschlußblock metrisch <i>Bloque distribuidor metrico</i>	Palier métrique		034.66764		1	
36	Bush <i>Bussola</i>	Buchse <i>Cojinete de fricción</i>	Bague	CST	034.59412		1	
37	Rotor-insert ass'y <i>Insieme rotore</i>	Rotor <i>Conjunto rotor</i>	Rotor et douille ass.	C	S24.10116	S24.30049	1	
38	Cam ring 003 <i>Anello camma 003</i>	Hubring 003 <i>Aro volumetrico 003</i>	Came 003	BC	034.59050		2	
	Cam ring 005 <i>Anello camma 005</i>	Hubring 005 <i>Aro volumetrico 005</i>	Came 005	BC	034.59051		2	
	Cam ring 006 <i>Anello camma 006</i>	Hubring 006 <i>Aro volumetrico 006</i>	Came 006	BC	034.59052		2	
	Cam ring 008 <i>Anello camma 008</i>	Hubring 008 <i>Aro volumetrico 008</i>	Came 008	BC	034.59053		2	
	Cam ring 010 <i>Anello camma 010</i>	Hubring 010 <i>Aro volumetrico 010</i>	Came 010	BC	034.59054		2	
	Cam ring 012 <i>Anello camma 012</i>	Hubring 012 <i>Aro volumetrico 012</i>	Came 012	BC	034.66595		2	

Item Pos. Réf. Pos. Pos.	Description Descrizione	Benennung Descripción	Description		Part N° Teil Nr. Code N° Cod. N° Referencia T6DC	Part N° Teil Nr. Code N° Cod. N° Referencia T6DCCM	Qty Stück Qté Q.tà Cant.	
38	Cam ring 014 <i>Anello camma 014</i>	Hubring 014 <i>Aro volumetrico 014</i>	Came 014	BC	034.59206		2	
	Cam ring 017 <i>Anello camma 017</i>	Hubring 017 <i>Aro volumetrico 017</i>	Came 017	BC	034.59207		2	
	Cam ring 020 <i>Anello camma 020</i>	Hubring 020 <i>Aro volumetrico 020</i>	Came 020	BC	034.66607		2	
	Cam ring 022 <i>Anello camma 022</i>	Hubring 022 <i>Aro volumetrico 022</i>	Came 022	BC	034.59208		2	
	Cam ring 025 <i>Anello camma 025</i>	Hubring 025 <i>Aro volumetrico 025</i>	Came 025	BC	034.59209		2	
	Cam ring 028 <i>Anello camma 028</i>	Hubring 028 <i>Aro volumetrico 028</i>	Came 028	BC	034.59245		2	
	Cam ring 031 <i>Anello camma 031</i>	Hubring 031 <i>Aro volumetrico 031</i>	Came 031	BC	034.66843		2	
	39	Sq. section seal <i>Guarnizione</i>	Dichtring <i>Junta seccion cuadrada</i>	Joint section carrée	CD	671.10156		1
	40	Back-up ring <i>Anello anti-estrusione</i>	Stützring <i>Anillo</i>	Bague anti-extrusion	CD	618.00010.3		1
41	Sq. section seal <i>Guarnizione</i>	Dichtring <i>Junta seccion cuadrada</i>	Joint section carrée	CD	691.10229		1	
42	Screw <i>Vite</i>	Schraube <i>Tornille</i>	Vis		306.40111		7	
43	Screw <i>Vite</i>	Schraube <i>Tornille</i>	Vis		306.40154		4	
44	Screw <i>Vite</i>	Schraube <i>Tornille</i>	Vis	CD	317.06266		4	
45	Screw <i>Vite</i>	Schraube <i>Tornille</i>	Vis	A	317.10320		2	
46	Screw <i>Vite</i>	Schraube <i>Tornille</i>	Vis		306.40156			
							4	
	REPAIR KIT KIT DI RICAMBIO	AUSTAUSCH-BAUGRUPPEN CUNJUNTO REPARACION	POCHETTES RECHANGES					
A	Cart. and plate ass'y *14 C.W. (P1) <i>Ins. cart. *14 oraria (P1)</i>	Pumpeneinheit *14 Rechtslauf (P1) <i>Conjunto cart. y platos *14 giro d. (P1)</i>	Cart. et plaque ass. *14 rot. d. (P1)		S24.33849	S24.40789	1	
A	Cart. and plate ass'y *14 C.C.W. (P1) <i>Ins. cart. *14 antioraria (P1)</i>	Pumpeneinheit *14 Linkslauf (P1) <i>Conjunto cart. y platos *14 giro i. (P1)</i>	Cart. et plaque ass. *14 rot. g. (P1)		S24.40598	S24.49790	1	
A	Cart. and plate ass'y *17 C.W. (P1) <i>Ins. cart. *17 oraria (P1)</i>	Pumpeneinheit *17 Rechtslauf (P1) <i>Conjunto cart. y platos *17 giro d. (P1)</i>	Cart. et plaque ass. *17 rot. d. (P1)		S24.58996	S24.63325	1	
A	Cart. and plate ass'y *17 C.C.W. (P1) <i>Ins. cart. *17 antioraria (P1)</i>	Pumpeneinheit *17 Linkslauf (P1) <i>Conjunto cart. y platos *17 giro i. (P1)</i>	Cart. et plaque ass. *17 rot. g. (P1)		S24.58997	S24.64242	1	
A	Cart. and plate ass'y *20 C.W. (P1) <i>Ins. cart. *20 oraria (P1)</i>	Pumpeneinheit *20 Rechtslauf (P1) <i>Conjunto cart. y platos *20 giro d. (P1)</i>	Cart. et plaque ass. *20 rot. d. (P1)		S24.26486	S24.30139	1	
A	Cart. and plate ass'y *20 C.C.W. (P1) <i>Ins. cart. *20 antioraria (P1)</i>	Pumpeneinheit *20 Linkslauf (P1) <i>Conjunto cart. y platos *20 giro i. (P1)</i>	Cart. et plaque ass. *20 rot. g. (P1)		S24.26487	S24.30140	1	
A	Cart. and plate ass'y *24 C.W. (P1) <i>Ins. cart. *24 oraria (P1)</i>	Pumpeneinheit *24 Rechtslauf (P1) <i>Conjunto cart. y platos *24 giro d. (P1)</i>	Cart. et plaque ass. *24 rot. d. (P1)		S14.97784	S24.30141	1	

Item Pos. Réf. Pos. Pos.	Description Descrizione	Benennung Descripción	Description	Part N° Teil Nr. Code N° Cod. N° Referencia T6DCC	Part N° Teil Nr. Code N° Cod. N° Referencia T6DCCM	Qty Stück Qté Q.tà Cant.
A	Cart. and plate ass'y *24 C.C.W. (P1) <i>Ins. cart. *24 antioraria (P1)</i>	Pumpeneinheit *24 Linkslauf (P1) <i>Conjunto cart. y platos *24 giro i. (P1)</i>	Cart. et plaque ass. *24 rot. g. (P1)	S24.25544	S24.30142	1
A	Cart. and plate ass'y *28 C.W. (P1) <i>Ins. cart. *28 oraria (P1)</i>	Pumpeneinheit *28 Rechtslauf (P1) <i>Conjunto cart. y platos *28 giro d. (P1)</i>	Cart. et plaque ass. *28 rot. d. (P1)	S24.10837	S24.30143	1
A	Cart. and plate ass'y *28 C.C.W. (P1) <i>Ins. cart. *28 antioraria (P1)</i>	Pumpeneinheit *28 Linkslauf (P1) <i>Conjunto cart. y platos *28 giro i. (P1)</i>	Cart. et plaque ass. *28 rot. g. (P1)	S24.10838	S24.30144	1
A	Cart. and plate ass'y *31 C.W. (P1) <i>Ins. cart. *31 oraria (P1)</i>	Pumpeneinheit *31 Rechtslauf (P1) <i>Conjunto cart. y platos *31 giro d. (P1)</i>	Cart. et plaque ass. *31 rot. d. (P1)	S24.10839	S24.30145	1
A	Cart. and plate ass'y *31 C.C.W. (P1) <i>Ins. cart. *31 antioraria (P1)</i>	Pumpeneinheit *31 Linkslauf (P1) <i>Conjunto cart. y platos *31 giro i. (P1)</i>	Cart. et plaque ass. *31 rot. g. (P1)	S24.10840	S24.30146	1
A	Cart. and plate ass'y *35 C.W. (P1) <i>Ins. cart. *35 oraria (P1)</i>	Pumpeneinheit *35 Rechtslauf (P1) <i>Conjunto cart. y platos *35 giro d. (P1)</i>	Cart. et plaque ass. *35 rot. d. (P1)	S24.10841	S24.30147	1
A	Cart. and plate ass'y *35 C.C.W. (P1) <i>Ins. cart. *35 antioraria (P1)</i>	Pumpeneinheit *35 Linkslauf (P1) <i>Conjunto cart. y platos *35 giro i. (P1)</i>	Cart. et plaque ass. *35 rot. g. (P1)	S24.10842	S24.30148	1
A	Cart. and plate ass'y *38 C.W. (P1) <i>Ins. cart. *38 oraria (P1)</i>	Pumpeneinheit *38 Rechtslauf (P1) <i>Conjunto cart. y platos *38 giro d. (P1)</i>	Cart. et plaque ass. *38 rot. d. (P1)	S24.10843	S24.30149	1
A	Cart. and plate ass'y *38 C.C.W. (P1) <i>Ins. cart. *38 antioraria (P1)</i>	Pumpeneinheit *38 Linkslauf (P1) <i>Conjunto cart. y platos *38 giro i. (P1)</i>	Cart. et plaque ass. *38 rot. g. (P1)	S24.10844	S24.30150	1
A	Cart. and plate ass'y *042 C.W. (P1) <i>Ins. cart. 042 oraria (P1)</i>	Pumpeneinheit 042 Rechtslauf (P1) <i>Conjunto cart. y platos 042 giro d. (P1)</i>	Cart. et plaque ass. 042 rot. d. (P1)	S24.10845	S24.30151	1
A	Cart. and plate ass'y 042 C.C.W. (P1) <i>Ins. cart. 042 antioraria (P1)</i>	Pumpeneinheit 042 Linkslauf (P1) <i>Conjunto cart. y platos 042 giro i. (P1)</i>	Cart. et plaque ass. 042 rot. g. (P1)	S24.10846	S24.30152	1
A	Cart. and plate ass'y *045 C.W. (P1) <i>Ins. cart. 045 oraria (P1)</i>	Pumpeneinheit 045 Rechtslauf (P1) <i>Conjunto cart. y platos 045 giro d. (P1)</i>	Cart. et plaque ass. 045 rot. d. (P1)	S24.10847	S24.30153	1
A	Cart. and plate ass'y 045 C.C.W. (P1) <i>Ins. cart. 045 antioraria (P1)</i>	Pumpeneinheit 045 Linkslauf (P1) <i>Conjunto cart. y platos 045 giro i. (P1)</i>	Cart. et plaque ass. 045 rot. g. (P1)	S24.10848	S24.30154	1
A	Cart. and plate ass'y *050 C.W. (P1) <i>Ins. cart. 050 oraria (P1)</i>	Pumpeneinheit 050 Rechtslauf (P1) <i>Conjunto cart. y platos 050 giro d. (P1)</i>	Cart. et plaque ass. 050 rot. d. (P1)	S24.40028	S24.40030	1
A	Cart. and plate ass'y 050 C.C.W. (P1) <i>Ins. cart. 050 antioraria (P1)</i>	Pumpeneinheit 050 Linkslauf (P1) <i>Conjunto cart. y platos 050 giro i. (P1)</i>	Cart. et plaque ass. 050 rot. g. (P1)	S24.40029	S24.40031	1
B	Cart. and plate ass'y *03 C.W. (P2) <i>Ins. cart. *03 oraria (P2)</i>	Pumpeneinheit *03 Rechtslauf (P2) <i>Conjunto cart. y platos *03 giro d. (P2)</i>	Cart. et plaque ass. *03 rot. d. (P2)	S24.25551	S24.40505	1
B	Cart. and plate ass'y *03 C.C.W. (P2) <i>Ins. cart. *03 antioraria (P2)</i>	Pumpeneinheit *03 Linkslauf (P2) <i>Conjunto cart. y platos *03 giro i. (P2)</i>	Cart. et plaque ass. *03 rot. g. (P2)	S24.25561	S24.40506	1
B	Cart. and plate ass'y *05 C.W. (P2) <i>Ins. cart. *05 oraria (P2)</i>	Pumpeneinheit *05 Rechtslauf (P2) <i>Conjunto cart. y platos *05 giro d. (P2)</i>	Cart. et plaque ass. *05 rot. d. (P2)	S24.25552	S24.40507	1
B	Cart. and plate ass'y *05 C.C.W. (P2) <i>Ins. cart. *05 antioraria (P2)</i>	Pumpeneinheit *05 Linkslauf (P2) <i>Conjunto cart. y platos *05 giro i. (P2)</i>	Cart. et plaque ass. *05 rot. g. (P2)	S24.25562	S24.40508	1
B	Cart. and plate ass'y *06 C.W. (P2) <i>Ins. cart. *06 oraria (P2)</i>	Pumpeneinheit *06 Rechtslauf (P2) <i>Conjunto cart. y platos *06 giro d. (P2)</i>	Cart. et plaque ass. *06 rot. d. (P2)	S24.25553	S24.40509	1
B	Cart. and plate ass'y *06 C.C.W. (P2) <i>Ins. cart. *06 antioraria (P2)</i>	Pumpeneinheit *06 Linkslauf (P2) <i>Conjunto cart. y platos *06 giro i. (P2)</i>	Cart. et plaque ass. *06 rot. g. (P2)	S24.25563	S24.40510	1
B	Cart. and plate ass'y *08 C.W. (P2) <i>Ins. cart. *08 oraria (P2)</i>	Pumpeneinheit *08 Rechtslauf (P2) <i>Conjunto cart. y platos *08 giro d. (P2)</i>	Cart. et plaque ass. *08 rot. d. (P2)	S24.25554	S24.40511	1
B	Cart. and plate ass'y *08 C.C.W. (P2) <i>Ins. cart. *08 antioraria (P2)</i>	Pumpeneinheit *08 Linkslauf (P2) <i>Conjunto cart. y platos *08 giro i. (P2)</i>	Cart. et plaque ass. *08 rot. g. (P2)	S24.25564	S24.40512	1
B	Cart. and plate ass'y *10 C.W. (P2) <i>Ins. cart. *10 oraria (P2)</i>	Pumpeneinheit *10 Rechtslauf (P2) <i>Conjunto cart. y platos *10 giro d. (P2)</i>	Cart. et plaque ass. *10 rot. d. (P2)	S24.25555	S24.40513	1
B	Cart. and plate ass'y *10 C.C.W. (P2) <i>Ins. cart. *10 antioraria (P2)</i>	Pumpeneinheit *10 Linkslauf (P2) <i>Conjunto cart. y platos *10 giro i. (P2)</i>	Cart. et plaque ass. *10 rot. g. (P2)	S24.25565	S24.40514	1

Item Pos. Réf. Pos. Pos.	Description Descrizione	Benennung Descripción	Description	Part N° Teil Nr. Code N° Cod. N° Referencia T6DCC	Part N° Teil Nr. Code N° Cod. N° Referencia T6DCCM	Qty Stück Qté Q.tà Cant.
B	Cart. and plate ass'y *12 C.W. (P2) <i>Ins. cart. *12 oraria (P2)</i>	Pumpeneinheit *12 Rechtslauf (P2) <i>Conjunto cart. y platos *12 giro d. (P2)</i>	Cart. et plaque ass. *12 rot. d. (P2)	S24.26484	S24.40515	1
B	Cart. and plate ass'y *12 C.C.W. (P2) <i>Ins. cart. *12 antioraria (P2)</i>	Pumpeneinheit *12 Linkslauf (P2) <i>Conjunto cart. y platos *12 giro i. (P2)</i>	Cart. et plaque ass. *12 rot. g. (P2)	S24.26485	S24.40516	1
B	Cart. and plate ass'y *14 C.W. (P2) <i>Ins. cart. *14 oraria (P2)</i>	Pumpeneinheit *14 Rechtslauf (P2) <i>Conjunto cart. y platos *14 giro d. (P2)</i>	Cart. et plaque ass. *14 rot. d. (P2)	S24.25556	S24.40517	1
B	Cart. and plate ass'y *14 C.C.W. (P2) <i>Ins. cart. *14 antioraria (P2)</i>	Pumpeneinheit *14 Linkslauf (P2) <i>Conjunto cart. y platos *14 giro i. (P2)</i>	Cart. et plaque ass. *14 rot. g. (P2)	S24.25566	S24.40518	1
B	Cart. and plate ass'y *17 C.W. (P2) <i>Ins. cart. *17 oraria (P2)</i>	Pumpeneinheit *17 Rechtslauf (P2) <i>Conjunto cart. y platos *17 giro d. (P2)</i>	Cart. et plaque ass. *17 rot. d. (P2)	S24.25557	S24.40519	1
B	Cart. and plate ass'y *17 C.C.W. (P2) <i>Ins. cart. *17 antioraria (P2)</i>	Pumpeneinheit *17 Linkslauf (P2) <i>Conjunto cart. y platos *17 giro i. (P2)</i>	Cart. et plaque ass. *17 rot. g. (P2)	S24.25567	S24.40520	1
B	Cart. and plate ass'y *20 C.W. (P2) <i>Ins. cart. *20 oraria (P2)</i>	Pumpeneinheit *20 Rechtslauf (P2) <i>Conjunto cart. y platos *20 giro d. (P2)</i>	Cart. et plaque ass. *20 rot. d. (P2)	S24.40352	S24.40521	1
B	Cart. and plate ass'y *20 C.C.W. (P2) <i>Ins. cart. *20 antioraria (P2)</i>	Pumpeneinheit *20 Linkslauf (P2) <i>Conjunto cart. y platos *20 giro i. (P2)</i>	Cart. et plaque ass. *20 rot. g. (P2)	S24.40353	S24.40522	1
B	Cart. and plate ass'y *22 C.W. (P2) <i>Ins. cart. *22 oraria (P2)</i>	Pumpeneinheit *22 Rechtslauf (P2) <i>Conjunto cart. y platos *22 giro d. (P2)</i>	Cart. et plaque ass. *22 rot. d. (P2)	S24.25558	S24.40523	1
B	Cart. and plate ass'y *22 C.C.W. (P2) <i>Ins. cart. *22 antioraria (P2)</i>	Pumpeneinheit *22 Linkslauf (P2) <i>Conjunto cart. y platos *22 giro i. (P2)</i>	Cart. et plaque ass. *22 rot. g. (P2)	S24.25568	S24.40524	1
B	Cart. and plate ass'y *25 C.W. (P2) <i>Ins. cart. *25 oraria (P2)</i>	Pumpeneinheit *25 Rechtslauf (P2) <i>Conjunto cart. y platos *25 giro d. (P2)</i>	Cart. et plaque ass. *25 rot. d. (P2)	S24.25559	S24.40525	1
B	Cart. and plate ass'y *25 C.C.W. (P2) <i>Ins. cart. *25 antioraria (P2)</i>	Pumpeneinheit *25 Linkslauf (P2) <i>Conjunto cart. y platos *25 giro i. (P2)</i>	Cart. et plaque ass. *25 rot. g. (P2)	S24.25569	S24.40526	1
B	Cart. and plate ass'y *28 C.W. (P2) <i>Ins. cart. *28 oraria (P2)</i>	Pumpeneinheit *28 Rechtslauf (P2) <i>Conjunto cart. y platos *28 giro d. (P2)</i>	Cart. et plaque ass. *28 rot. d. (P2)	S24.25560	S24.40527	1
B	Cart. and plate ass'y *28 C.C.W. (P2) <i>Ins. cart. *28 antioraria (P2)</i>	Pumpeneinheit *28 Linkslauf (P2) <i>Conjunto cart. y platos *28 giro i. (P2)</i>	Cart. et plaque ass. *28 rot. g. (P2)	S24.25570	S24.40528	1
B	Cart. and plate ass'y *31 C.W. (P2) <i>Ins. cart. *31 oraria (P2)</i>	Pumpeneinheit *31 Rechtslauf (P2) <i>Conjunto cart. y platos *31 giro d. (P2)</i>	Cart. et plaque ass. *31 rot. d. (P2)	S24.45773	S24.45777	1
B	Cart. and plate ass'y *31 C.C.W. (P2) <i>Ins. cart. *31 antioraria (P2)</i>	Pumpeneinheit *31 Linkslauf (P2) <i>Conjunto cart. y platos *31 giro i. (P2)</i>	Cart. et plaque ass. *31 rot. g. (P2)	S24.45774	S24.45778	1
C	Cart. and plate ass'y *03 C.W. (P3) <i>Ins. cart. *03 oraria (P3)</i>	Pumpeneinheit *03 Rechtslauf (P3) <i>Conjunto cart. y platos *03 giro d. (P3)</i>	Cart. et plaque ass. *03 rot. d. (P3)	S24.10749	S24.40200	1
C	Cart. and plate ass'y *03 C.C.W. (P3) <i>Ins. cart. *03 antioraria (P3)</i>	Pumpeneinheit *03 Linkslauf (P3) <i>Conjunto cart. y platos *03 giro i. (P3)</i>	Cart. et plaque ass. *03 rot. g. (P3)	S24.10750	S24.40201	1
C	Cart. and plate ass'y *05 C.W. (P3) <i>Ins. cart. *05 oraria (P3)</i>	Pumpeneinheit *05 Rechtslauf (P3) <i>Conjunto cart. y platos *05 giro d. (P3)</i>	Cart. et plaque ass. *05 rot. d. (P3)	S24.10751	S24.40202	1
C	Cart. and plate ass'y *05 C.C.W. (P3) <i>Ins. cart. *05 antioraria (P3)</i>	Pumpeneinheit *05 Linkslauf (P3) <i>Conjunto cart. y platos *05 giro i. (P3)</i>	Cart. et plaque ass. *05 rot. g. (P3)	S24.10752	S24.40203	1
C	Cart. and plate ass'y *06 C.W. (P3) <i>Ins. cart. *06 oraria (P3)</i>	Pumpeneinheit *06 Rechtslauf (P3) <i>Conjunto cart. y platos *06 giro d. (P3)</i>	Cart. et plaque ass. *06 rot. d. (P3)	S24.10753	S24.40204	1
C	Cart. and plate ass'y *06 C.C.W. (P3) <i>Ins. cart. *06 antioraria (P3)</i>	Pumpeneinheit *06 Linkslauf (P3) <i>Conjunto cart. y platos *06 giro i. (P3)</i>	Cart. et plaque ass. *06 rot. g. (P3)	S24.10754	S24.40205	1
C	Cart. and plate ass'y *08 C.W. (P3) <i>Ins. cart. *08 oraria (P3)</i>	Pumpeneinheit *08 Rechtslauf (P3) <i>Conjunto cart. y platos *08 giro d. (P3)</i>	Cart. et plaque ass. *08 rot. d. (P3)	S24.10755	S24.40206	1
C	Cart. and plate ass'y *08 C.C.W. (P3) <i>Ins. cart. *08 antioraria (P3)</i>	Pumpeneinheit *08 Linkslauf (P3) <i>Conjunto cart. y platos *08 giro i. (P3)</i>	Cart. et plaque ass. *08 rot. g. (P3)	S24.10756	S24.40207	1
C	Cart. and plate ass'y *10 C.W. (P3) <i>Ins. cart. *10 oraria (P3)</i>	Pumpeneinheit *10 Rechtslauf (P3) <i>Conjunto cart. y platos *10 giro d. (P3)</i>	Cart. et plaque ass. *10 rot. d. (P3)	S24.10757	S24.40208	1

Item Pos. Réf. Pos.	Description Descrizione	Benennung Descripción	Description		Part N° Teil Nr. Code N° Cod. N° Referencia T6DCC	Part N° Teil Nr. Code N° Cod. N° Referencia T6DCCM	Qty Stück Qté Q.tà Cant.
C	Cart. and plate ass'y *10 C.C.W. (P3) <i>Ins. cart. *10 antioraria (P3)</i>	Pumpeneinheit *10 Linkslauf (P3) <i>Conjunto cart. y platos *10 giro i. (P3)</i>	Cart. et plaque ass. *10 rot. g. (P3)		S24.10758	S24.40209	1
C	Cart. and plate ass'y *12 C.W. (P3) <i>Ins. cart. *12 oraria (P3)</i>	Pumpeneinheit *12 Rechtslauf (P3) <i>Conjunto cart. y platos *12 giro d. (P3)</i>	Cart. et plaque ass. *12 rot. d. (P3)		S24.26482	S24.40210	1
C	Cart. and plate ass'y *12 C.C.W. (P3) <i>Ins. cart. *12 antioraria (P3)</i>	Pumpeneinheit *12 Linkslauf (P3) <i>Conjunto cart. y platos *12 giro i. (P3)</i>	Cart. et plaque ass. *12 rot. g. (P3)		S24.26483	S24.40211	1
C	Cart. and plate ass'y *14 C.W. (P3) <i>Ins. cart. *14 oraria (P3)</i>	Pumpeneinheit *14 Rechtslauf (P3) <i>Conjunto cart. y platos *14 giro d. (P3)</i>	Cart. et plaque ass. *14 rot. d. (P3)		S24.10759	S24.40212	1
C	Cart. and plate ass'y *14 C.C.W. (P3) <i>Ins. cart. *14 antioraria (P3)</i>	Pumpeneinheit *14 Linkslauf (P3) <i>Conjunto cart. y platos *14 giro i. (P3)</i>	Cart. et plaque ass. *14 rot. g. (P3)		S24.10760	S24.40213	1
C	Cart. and plate ass'y *17 C.W. (P3) <i>Ins. cart. *17 oraria (P3)</i>	Pumpeneinheit *17 Rechtslauf (P3) <i>Conjunto cart. y platos *17 giro d. (P3)</i>	Cart. et plaque ass. *17 rot. d. (P3)		S24.10761	S24.40214	1
C	Cart. and plate ass'y *17 C.C.W. (P3) <i>Ins. cart. *17 antioraria (P3)</i>	Pumpeneinheit *17 Linkslauf (P3) <i>Conjunto cart. y platos *17 giro i. (P3)</i>	Cart. et plaque ass. *17 rot. g. (P3)		S24.10762	S24.40215	1
C	Cart. and plate ass'y *20 C.W. (P3) <i>Ins. cart. *20 oraria (P3)</i>	Pumpeneinheit *20 Rechtslauf (P3) <i>Conjunto cart. y platos *20 giro d. (P3)</i>	Cart. et plaque ass. *20 rot. d. (P3)		S24.31023	S24.40216	1
C	Cart. and plate ass'y *20 C.C.W. (P3) <i>Ins. cart. *20 antioraria (P3)</i>	Pumpeneinheit *20 Linkslauf (P3) <i>Conjunto cart. y platos *20 giro i. (P3)</i>	Cart. et plaque ass. *20 rot. g. (P3)		S24.40032	S24.40217	1
C	Cart. and plate ass'y *22 C.W. (P3) <i>Ins. cart. *22 oraria (P3)</i>	Pumpeneinheit *22 Rechtslauf (P3) <i>Conjunto cart. y platos *22 giro d. (P3)</i>	Cart. et plaque ass. *22 rot. d. (P3)		S24.10763	S24.40218	1
C	Cart. and plate ass'y *22 C.C.W. (P3) <i>Ins. cart. *22 antioraria (P3)</i>	Pumpeneinheit *22 Linkslauf (P3) <i>Conjunto cart. y platos *22 giro i. (P3)</i>	Cart. et plaque ass. *22 rot. g. (P3)		S24.10764	S24.40219	1
C	Cart. and plate ass'y *25 C.W. (P3) <i>Ins. cart. *25 oraria (P3)</i>	Pumpeneinheit *25 Rechtslauf (P3) <i>Conjunto cart. y platos *25 giro d. (P3)</i>	Cart. et plaque ass. *25 rot. d. (P3)		S24.10765	S24.40220	1
C	Cart. and plate ass'y *25 C.C.W. (P3) <i>Ins. cart. *25 antioraria (P3)</i>	Pumpeneinheit *25 Linkslauf (P3) <i>Conjunto cart. y platos *25 giro i. (P3)</i>	Cart. et plaque ass. *25 rot. g. (P3)		S24.10766	S24.40221	1
C	Cart. and plate ass'y *28 C.W. (P3) <i>Ins. cart. *28 oraria (P3)</i>	Pumpeneinheit *28 Rechtslauf (P3) <i>Conjunto cart. y platos *28 giro d. (P3)</i>	Cart. et plaque ass. *28 rot. d. (P3)		S24.25547	S24.40222	1
C	Cart. and plate ass'y *28 C.C.W. (P3) <i>Ins. cart. *28 antioraria (P3)</i>	Pumpeneinheit *28 Linkslauf (P3) <i>Conjunto cart. y platos *28 giro i. (P3)</i>	Cart. et plaque ass. *28 rot. g. (P3)		S24.25546	S24.40223	1
C	Cart. and plate ass'y *31 C.W. (P3) <i>Ins. cart. *31 oraria (P3)</i>	Pumpeneinheit *31 Rechtslauf (P3) <i>Conjunto cart. y platos *31 giro d. (P3)</i>	Cart. et plaque ass. *31 rot. d. (P3)		S24.45771	S24.45775	1
C	Cart. and plate ass'y *31 C.C.W. (P3) <i>Ins. cart. *31 antioraria (P3)</i>	Pumpeneinheit *31 Linkslauf (P3) <i>Conjunto cart. y platos *31 giro i. (P3)</i>	Cart. et plaque ass. *31 rot. g. (P3)		S24.45772	S24.45776	1
D	Seal kit (S1 - 0,7 bar) <i>Serie guarnizioni (S1 - 0,7 bar)</i>	Dichtringsatz (S1 - 0,7 bar) <i>Juego de juntas (S1 - 0,7 bar)</i>	Pochette de joint (S1 - 0,7 bar)		S24.25575		1
	Seal kit (S4 - 7 bar) <i>Serie guarnizioni (S4 - 7 bar)</i>	Dichtringsatz (S4 - 7 bar) <i>Juego de juntas (S4 - 7 bar)</i>	Pochette de joint (S4 - 7 bar)		S24.25575.4		1
	Seal kit (S5 - 7 bar) <i>Serie guarnizioni (S5 - 7 bar)</i>	Dichtringsatz (S5 - 7 bar) <i>Juego de juntas (S5 - 7 bar)</i>	Pochette de joint (S5 - 7 bar)		S24.25575.5		1
	Shaft and bearing ass'y (code 1) <i>Ins. albero (codice 1)</i>	Baugruppe (Welle u. Lager) (Typ 1) <i>Conjunto eje cojinete (codigo 1)</i>	Arbre et roulement ass. (code 1)		S24.25571		1
Shaft and bearing ass'y (code 2) <i>Ins. albero (codice 2)</i>	Baugruppe (Welle u. Lager) (Typ 2) <i>Conjunto eje cojinete (codigo 2)</i>	Arbre et roulement ass. (code 2)		S24.25572		1	
Shaft and bearing ass'y (code 3) <i>Ins. albero (codice 3)</i>	Baugruppe (Welle u. Lager) (Typ 3) <i>Conjunto eje cojinete (codigo 3)</i>	Arbre et roulement ass. (code 3)		S24.25573		1	
Shaft and bearing ass'y (code 4) <i>Ins. albero (codice 4)</i>	Baugruppe (Welle u. Lager) (Typ 4) <i>Conjunto eje cojinete (codigo 4)</i>	Arbre et roulement ass. (code 4)		S24.25574		1	
J	Shaft and bearing ass'y (code 6) <i>Ins. albero (codice 6)</i>	Baugruppe (Welle u. Lager) (Typ 6) <i>Conjunto eje cojinete (codigo 6)</i>	Arbre et roulement ass. (code 6)			S24.40504	1

Item Pos. Ref. Pos. Pos.	Description <i>Descrizione</i>	Benennung <i>Descripcion</i>	Description		Part N° Teil Nr. Code N° Cod. N° Referencia T6DCC	Part N° Teil Nr. Code N° Cod. N° Referencia T6DCCM	Qty Stück Qté Q.tà Cant.
K	Port plate rear and bush ass'y C.C.W. (P1) <i>Ins. piatto distributore post. antioraria (P1)</i>	Steuerplatte mit Buchse Linkslauf (P1) <i>Conj. plato dist. tras. con coj. fricción giro I (P1)</i>	Plaque arrière et bague ass. rot. gauche (P1)		S24.63710		1
L	Port plate rear and bush ass'y C.W. (P1) <i>Ins. piatto distributore post. oraria (P1)</i>	Steuerplatte mit Buchse Rechtslauf (P1) <i>Conj. plato dist. tras. con coj. fricción giro D (P1)</i>	Plaque arrière et bague ass. rot. droite (P1)		S24.63709		1
M	Port plate rear and bush ass'y (P1) <i>Ins. piatto distributore post. (P1)</i>	Steuerplatte mit Buchse (P1) <i>Conj. plato dist. tras. con coj. fricción (P1)</i>	Plaque arrière et bague ass. (P1)			S24.10122	1
N	Port plate rear ass'y C.C.W. (P2) <i>Ins. piatto distributore post. antioraria (P2)</i>	Steuerplatte Linkslauf (P2) <i>Conj. plato dist. trasero giro I (P2)</i>	Plaque arrière ass. rot. gauche (P2)		S24.10805		1
P	Port plate rear ass'y C.W. (P2) <i>Ins. piatto distributore post. oraria (P2)</i>	Steuerplatte Rechtslauf (P2) <i>Conj. plato dist. trasero giro D (P2)</i>	Plaque arrière ass. rot. droite (P2)		S24.10806		1
R	Port plate rear ass'y (P2) <i>Ins. piatto distributore post. (P2)</i>	Steuerplatte (P2) <i>Conj. plato dist. trasero (P2)</i>	Plaque arrière ass. (P2)			S24.10418	1
S	Port plate rear and bush ass'y C.C.W. (P3) <i>Ins. piatto distributore post. antioraria (P3)</i>	Steuerplatte mit Buchse Linkslauf (P3) <i>Conj. plato dist. tras. con coj. fricción giro I (P3)</i>	Plaque arrière et bague ass. rot. gauche (P3)		S24.10808		1
T	Port plate rear and bush ass'y C.W. (P3) <i>Ins. piatto distributore post. oraria (P3)</i>	Steuerplatte mit Buchse Rechtslauf (P3) <i>Conj. plato dist. tras. con coj. fricción giro D (P3)</i>	Plaque arrière et bague ass. rot. droite (P3)		S24.10807		1
U	Port plate rear and bush ass'y (P3) <i>Ins. piatto distributore post. (P3)</i>	Steuerplatte mit Buchse (P3) <i>Conj. plato dist. tras. con coj. fricción (P3)</i>	Plaque arrière et bague ass. (P3)			S24.10349	1
Notes							

Model Code

Typenschlüssel

Désignation - type

Model number :

Typenbezeichnung :

Numéro du modèle :

T6DCC . - 038 - 028 - 008 - 1 R 00 - A 1 - 00 - ..

Series

Baureihe

Série

One letter can be added to specify special parts in series

Optionen

Une lettre peut être ajoutée pour spécifier les pièces spéciales dans la série.

Cam ring for P1

(Volumetric displacement) (ml/rev.)

014 = 47,6
017 = 58,2
020 = 66,0
024 = 79,5

Hubring P1

(Geometrisches Fördervolumen) (cm³/U)

028 = 89,7
031 = 98,3
035 = 111,0
038 = 120,3

Came pour P1

(Cylindrée théorique) (cm³/tr)

042 = 136,0
045 = 145,7
050 = 158,0

Cam ring for P2 and P3

(Volumetric displacement) (ml/rev.)

003 = 10,8
005 = 17,2
006 = 21,3
008 = 26,4
010 = 34,1

Hubring P2 und P3

(Geometrisches Fördervolumen) (cm³/U)

012 = 37,1
014 = 46,0
017 = 58,3
020 = 63,8

Came pour P2 et P3

(Cylindrée théorique) (cm³/tr)

022 = 70,3
025 = 79,3
028 = 88,8
031 = 100,0

Type of shaft

1 = keyed (no SAE)
2 = keyed (SAE CC)
3 = splined (SAE C)
4 = splined (SAE CC)

Art der Welle

1 = Paßfederwelle (nicht SAE)
2 = Paßfederwelle (SAE CC)
3 = Vielkeilwelle (SAE C)
4 = Vielkeilwelle (SAE CC)

Type d'arbre

1 = à clavette (non SAE)
2 = à clavette (SAE CC)
3 = à cannelures (SAE C)
4 = à cannelures (SAE CC)

Direction of rotation

R = Clockwise
L = Counter-clockwise

Drehrichtung

R = Rechtslauf
L = Linkslauf

Sens de rotation

R = à droite
L = à gauche

Porting combination

00 = standard

Lage der Anschlüsse

0 = standard

Combinaison des orifices

00 = standard

Design letter

Ausführungsbuchstabe

Conception

Seal class

1 = S1 - BUNA N
4 = S4 - EPDM
5 = S5 - VITON

Dichtungsklasse

1 = S1 - BUNA N
4 = S4 - EPDM
5 = S5 - VITON

Classe de joint

1 = S1 - BUNA N
4 = S4 - EPDM
5 = S5 - VITON

Mounting w/connection variables

4 bolts SAE flange (J518c)

SAE	P1 = 1"1/4 - S = 4" - P2 = 1"		metric	
	UNC			
P3	1"	3/4"	1"	3/4"
Code	00	01	M0	M1

Gehäuse-Anschlußgröße

SAE Flansch (J518c)

SAE	P1 = 1"1/4 - S = 4" - P2 = 1"		metrisch	
	UNC			
P3	1"	3/4"	1"	3/4"
Typ	00	01	M0	M1

Option sur orifices

Bride SAE 4 trous (J518c)

SAE	P1 = 1"1/4 - S = 4" - P2 = 1"		métrique	
	UNC			
P3	1"	3/4"	1"	3/4"
Code	00	01	M0	M1

Modifications

Modifikationen

Modifications

Designazione

Clave de designación

Sigla :

Referencia modelo :

T6DCC - 038 - 028 - 008 - 1 R 00 - A 1 - 00 - ..

Serie _____

Serie _____

Una lettera può essere aggiunta per specificare parti speciali nella serie

Una letra puede ser añadida para especificar piezas especiales en la serie

Tipo di cartuccia P1

(Cilindrata) (ml/giro)

014 = 47,6
017 = 58,2
020 = 66,0
024 = 79,5
028 = 89,7
031 = 98,3

Aro volumetrico para P1

(Cilindrada) (ml/rev)

035 = 111,0
038 = 120,3
042 = 136,0
045 = 145,7
050 = 158,0

Tipo di cartuccia P2 & P3

(Cilindrata) (ml/giro)

003 = 10,8
005 = 17,2
006 = 21,3
008 = 26,4
010 = 34,1
012 = 37,1
014 = 46,0

Aro volumetrico para P2 y P3

(Cilindrada) (ml/rev)

017 = 58,3
020 = 63,8
022 = 70,3
025 = 79,3
028 = 88,8
031 = 100,0

Tipo di albero

1 = a chiavetta
2 = a chiavetta (SAE CC)
3 = scanalato (SAE C)
4 = scanalato (SAE CC)

Tipo de eje

1 = chaveteado (no SAE)
2 = chaveteado (SAE CC)
3 = estriado (SAE C)
4 = estriado (SAE CC)

Senso di rotazione

R = Orario
L = Antiorario

Sentido de giro

R = Derecha
L = Izquierda

Orientamento delle bocche

00 = standard

Posición de bocas

00 = estándar

Disegno

Letra de diseño

Tipo di guarnizioni

1 = S1 - BUNA N
4 = S4 - EPDM
5 = S5 - VITON

Clase de juntas

1 = S1 - BUNA N
4 = S4 - EPDM
5 = S5 - VITON

Dimensioni delle bocche

Flangia SAE 4 drenaggio (J518c)

SAE	P1 = 1"1/4 - S = 4" - P2 = 1"			
	UNC		metrico	
P3	1"	3/4"	1"	3/4"
Codice	00	01	M0	M1

Conexiones de montaje

Flange SAE 4 fori (J518c)

SAE	P1 = 1"1/4 - S = 4" - P2 = 1"			
	UNC		metrica	
P3	1"	3/4"	1"	3/4"
Codigo	00	01	M0	M1

Modifiche

Modificaciones

Model Code

Typenschlüssel

Désignation - type

Model number :

Typenbezeichnung :

Numéro du modèle :

T6DCCM - B38 - B28 - B08 - 1 R 00 - B 1 - 00 - ..

Series

Baureihe

Série

One letter can be added to specify special parts in series

Optionen

Une lettre peut être ajoutée pour spécifier les pièces spéciales dans la série.

Cam ring for P1

(Volumetric displacement) (ml/rev.)

014 = 47,6
017 = 58,2
020 = 66,0
024 = 79,5

Hubring P1

(Geometrisches Fördervolumen) (cm³/U)

028 = 89,7
031 = 98,3
035 = 111,0
038 = 120,3

Came pour P1

(Cylindrée théorique) (cm³/tr)

042 = 136,0
045 = 145,7
050 = 158,0

Cam ring for P2 and P3

(Volumetric displacement) (ml/rev.)

B03 = 10,8
B05 = 17,2
B06 = 21,3
B08 = 26,4
B10 = 34,1

Hubring P2 und P3

(Geometrisches Fördervolumen) (cm³/U)

B12 = 37,1
B14 = 46,0
B17 = 58,3
B20 = 63,8

Came pour P2 et P3

(Cylindrée théorique) (cm³/tr)

B22 = 70,3
B25 = 79,3
B28 = 88,8
B31 = 100,0

Type of shaft

1 = keyed (no SAE)
2 = keyed (SAE CC)
3 = splined (SAE C)
4 = splined (SAE CC)
6 = splined (no SAE)

Art der Welle

1 = Paßfederwelle (nicht SAE)
2 = Paßfederwelle (SAE CC)
3 = Vielkeilwelle (SAE C)
4 = Vielkeilwelle (SAE CC)
6 = Vielkeilwelle (nicht SAE)

Type d'arbre

1 = à clavette (non SAE)
2 = à clavette (SAE CC)
3 = à cannelures (SAE C)
4 = à cannelures (SAE CC)
6 = à cannelures (non SAE)

Direction of rotation

R = Clockwise
L = Counter-clockwise

Drehrichtung

R = Rechtslauf
L = Linkslauf

Sens de rotation

R = à droite
L = à gauche

Porting combination

00 = standard

Lage der Anschlüsse

0 = standard

Combinaison des orifices

00 = standard

Design letter

Ausführungsbuchstabe

Conception

Seal class

1 = S1 - BUNA N
4 = S4 - EPDM
5 = S5 - VITON

Dichtungsklasse

1 = S1 - BUNA N
4 = S4 - EPDM
5 = S5 - VITON

Classe de joint

1 = S1 - BUNA N
4 = S4 - EPDM
5 = S5 - VITON

Mounting w/connection variables

4 bolts SAE flange (J518c)

SAE	P1 = 1"1/4 - S = 4" - P2 = 1"		metric	
	UNC			
P3	1"	3/4"	1"	3/4"
Code	00	01	M0	M1

Gehäuse-Anschlußgröße

SAE Flansch (J518c)

SAE	P1 = 1"1/4 - S = 4" - P2 = 1"		metrisch	
	UNC			
P3	1"	3/4"	1"	3/4"
Typ	00	01	M0	M1

Option sur orifices

Bride SAE 4 trous (J518c)

SAE	P1 = 1"1/4 - S = 4" - P2 = 1"		métrique	
	UNC			
P3	1"	3/4"	1"	3/4"
Code	00	01	M0	M1

Modifications

Modifikationen

Modifications

Designazione

Clave de designación

Sigla :

Referencia modelo :

T6DCCM . - B38 - B28 - B08 - 1 R 00 - B 1 - 00 - ..

Serie _____ **Serie** _____

Una lettera può essere aggiunta per specificare parti speciali nella serie _____ Una letra puede ser añadida para especificar piezas especiales en la serie _____

Tipo di cartuccia P1

(Cilindrata) (ml/giro)

014 = 47,6
017 = 58,2
020 = 66,0
024 = 79,5
028 = 89,7
031 = 98,3

Aro volumetrico para P1

(Cilindrada) (ml/rev)

035 = 111,0
038 = 120,3
042 = 136,0
045 = 145,7
050 = 158,0

Tipo di cartuccia P2 & P3

(Cilindrata) (ml/giro)

B03 = 10,8
B05 = 17,2
B06 = 21,3
B08 = 26,4
B10 = 34,1
B12 = 37,1
B14 = 46,0

Aro volumetrico para P2 y P3

(Cilindrada) (ml/rev)

B17 = 58,3
B20 = 63,8
B22 = 70,3
B25 = 79,3
B28 = 88,8
B31 = 100,0

Tipo di albero

1 = a chiavetta
2 = a chiavetta (SAE CC)
3 = scanalato (SAE C)
4 = scanalato (SAE CC)
6 = scanalato

Tipo de eje

1 = chaveteado (no SAE)
2 = chaveteado (SAE CC)
3 = estriado (SAE C)
4 = estriado (SAE CC)
6 = estriado (no SAE)

Senso di rotazione

R = Orario
L = Antiorario

Sentido de giro

R = Derecha
L = Izquierda

Orientamento delle bocche

00 = standard

Posición de bocas

00 = estándar

Disegno

Letra de diseño

Tipo di guarnizioni

1 = S1 - BUNA N
4 = S4 - EPDM
5 = S5 - VITON

Clase de juntas

1 = S1 - BUNA N
4 = S4 - EPDM
5 = S5 - VITON

Dimensioni delle bocche

Flangia SAE 4 drenaggio (J518c)

SAE	P1 = 1"1/4 - S = 4" - P2 = 1"			
	UNC		metrico	
P3	1"	3/4"	1"	3/4"
Codice	00	01	M0	M1

Conexiones de montaje

Flange SAE 4 fori (J518c)

SAE	P1 = 1"1/4 - S = 4" - P2 = 1"			
	UNC		metrica	
P3	1"	3/4"	1"	3/4"
Codigo	00	01	M0	M1

Modifiche

Modificaciones