

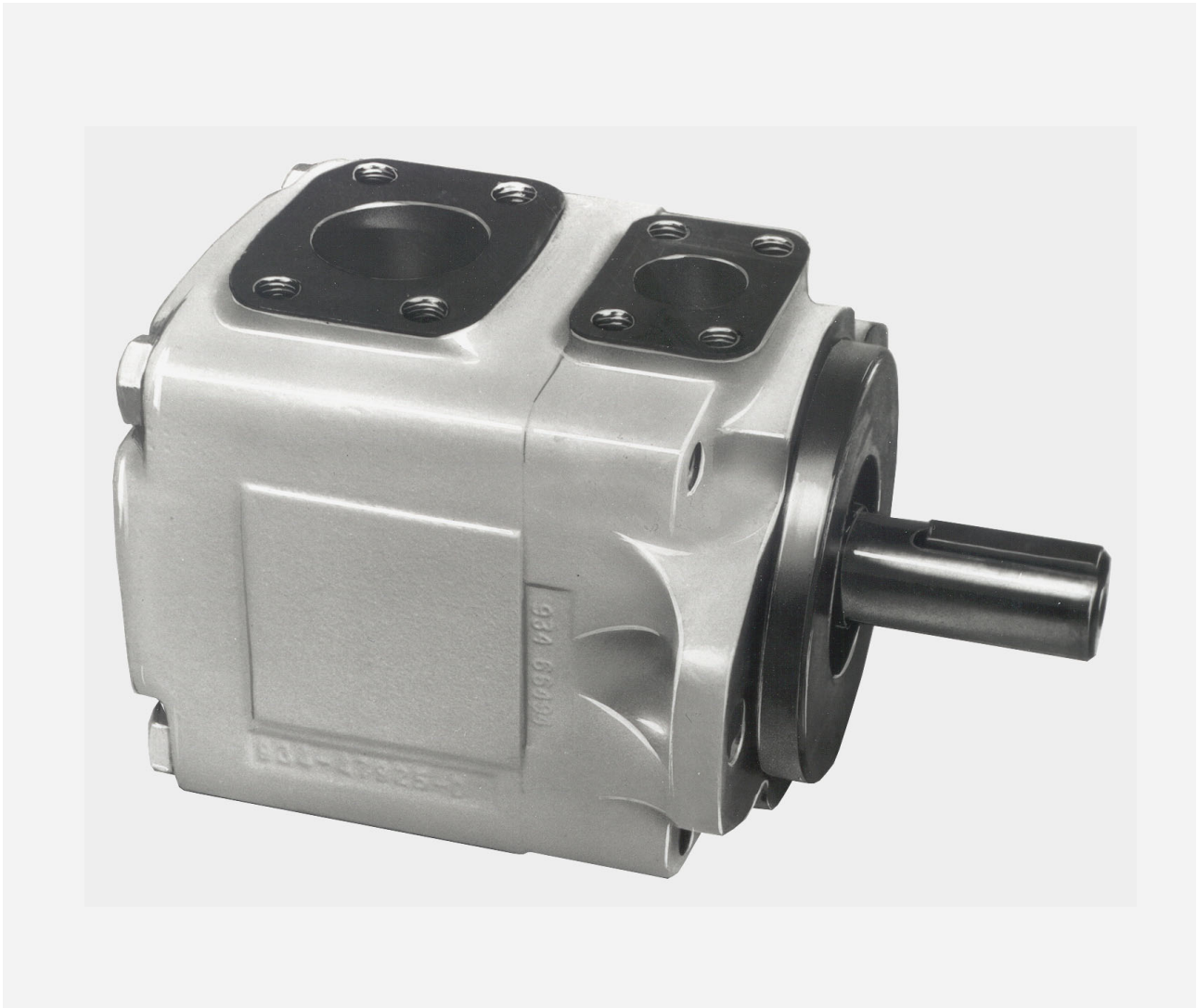

Vane pumps Service information

vane-type single pump / Flügelzellen-Einzelpumpe
pompe simple à palettes / pompa semplice a palettes
tipo bomba de paletas simple
T6D - T6DM - T6DP



Publ. S1 - ML0503 - C

03 / 2003 / FB

Replaces : S1 - ML0503 - B

L25 - 10503 - 3

DENISON | Hydraulics

Recommended repair kits and assy's are bold printed
 Empfohlene Austausch - Baugruppen sind fett gedruckt
 Les pochettes de rechange recommandées sont imprimées en caractères gras
 I kit di ricambio consigliati sono indicati in grassetto
 Los juegos de reparacion recomendados y los conjuntos, estan en negrita

	Item - Pos. - Réf. - Pos.	
	23	
Mounting torque	187 Nm	138 ft.lbs
Anziehdrehmoment		
Couple de serrage		
Coppia di serraggio		
Par de apriete		

T6D INDUSTRIAL

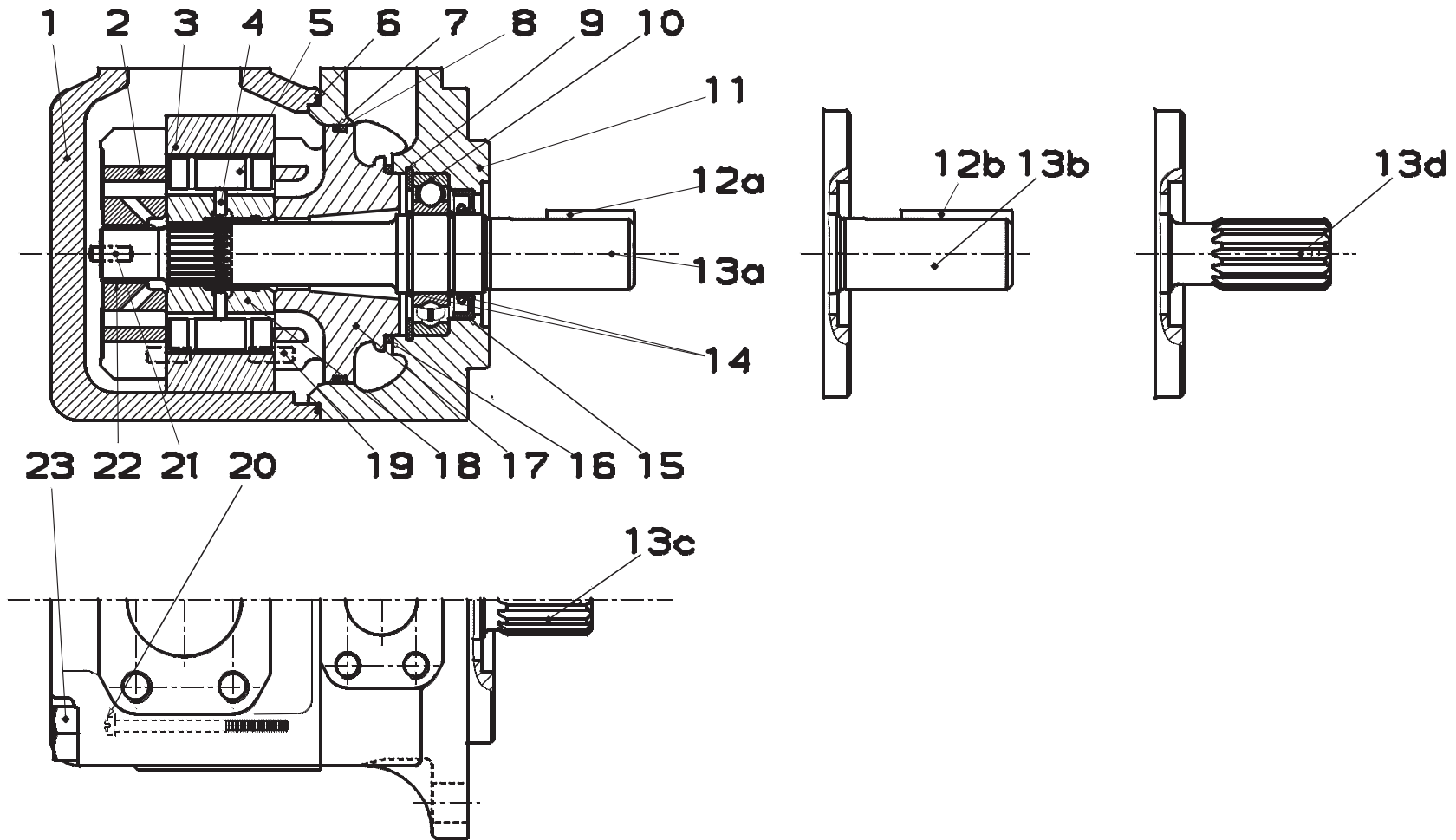

Recommended repair kits and assy's are bold printed
 Empfohlene Austausch - Baugruppen sind fett gedruckt
 Les pochettes de rechange recommandées sont imprimées en caractères gras
 I kit di ricambio consigliati sono indicati in grassetto
 Los juegos de reparacion recomendados y los conjuntos, estan en negrita

	Item - Pos. - Réf. - Pos.	
	23	
Mounting torque		
Anziehdrehmoment		
Couple de serrage	187 Nm	138 ft.lbs
Coppia di serragio		
Par de apriete		

T6DM MOBILE

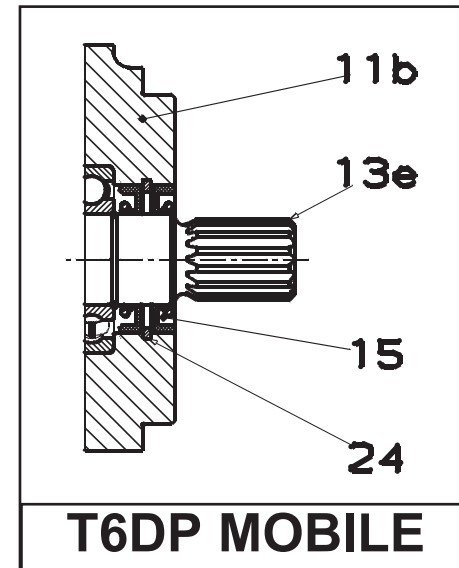
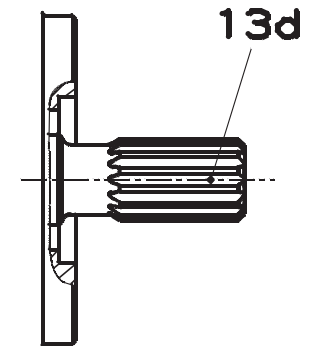
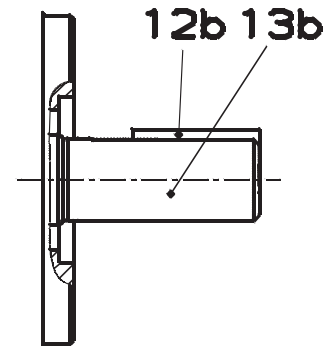
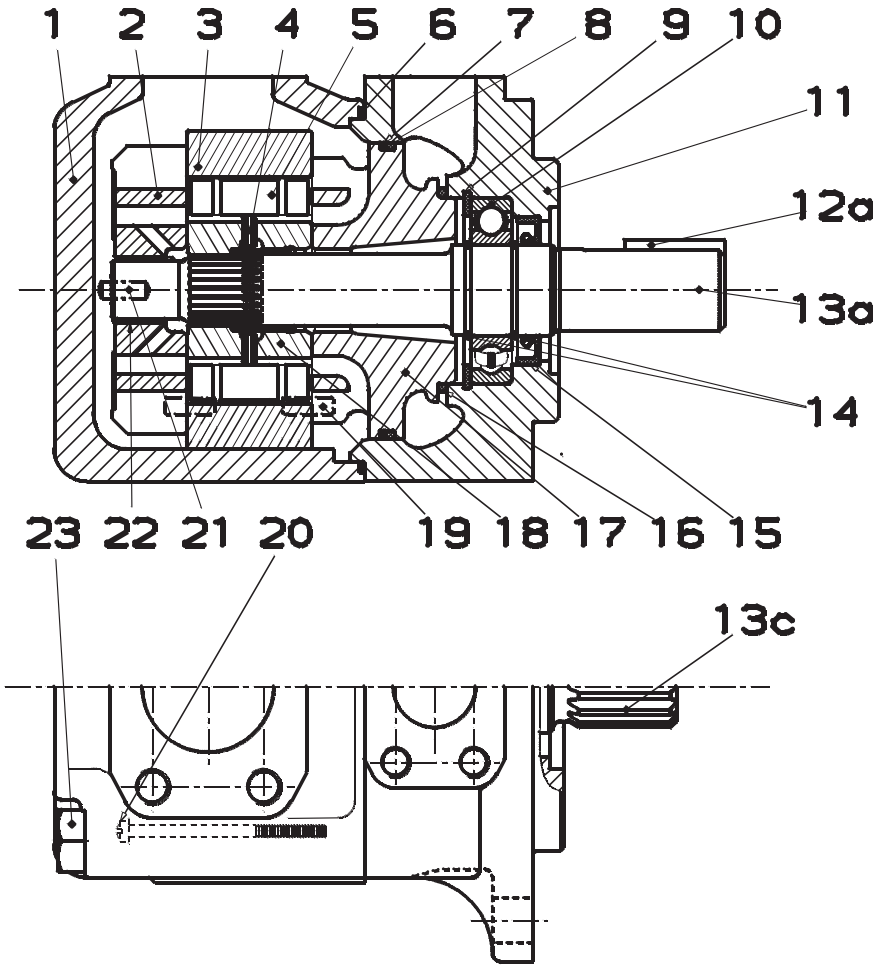

T6DP MOBILE

Item Pos. Ref. Pos. Pos.	Description <i>Descrizione</i>	Benennung <i>Descripcion</i>	Description		Part N° Teil Nr. Code N° Cod. N° Referencia T6D	Part N° Teil Nr. Code N° Cod. N° Referencia T6DM - T6DP	Qty Stück Qté Q.tà Cant.
1	Housing (standard) <i>Corpo (standard)</i>	Gehäuse (Standard) <i>Cuerpo (estandar)</i>	Carter (standard)		034.47917	034.47917	1
2	Port plate-rear C.C.W. <i>Piatto distributore post. antioraria</i>	Steuerplatte Linkslauf <i>Plato distribuidor trasero giro I</i>	Plaque arrière rotation gauche	AG	034.67114		1
	Port plate-rear C.W. <i>Piatto distributore post. oraria</i>	Steuerplatte Rechtslauf <i>Plato distribuidor trasero giro D</i>	Plaque arrière rotation droite	AH	034.67112		1
	Port plate-rear <i>Piatto distributore</i>	Steuerplatte <i>Plato distribuidor trasero</i>	Plaque arrière	AJ		034.59101	1
3	Cam ring 014 <i>Anello camma 014</i>	Hubring 014 <i>Aro volumetrico 014</i>	Came 014	A	034.66708	034.66708	1
	Cam ring 017 <i>Anello camma 017</i>	Hubring 017 <i>Aro volumetrico 017</i>	Came 017	A	034.67028	034.67028	1
	Cam ring 020 <i>Anello camma 020</i>	Hubring 020 <i>Aro volumetrico 020</i>	Came 020	A	034.66596	034.66596	1
	Cam ring 024 <i>Anello camma 024</i>	Hubring 024 <i>Aro volumetrico 024</i>	Came 024	A	034.59294	034.59294	1
	Cam ring 028 <i>Anello camma 028</i>	Hubring 028 <i>Aro volumetrico 028</i>	Came 028	A	034.59133	034.59133	1
	Cam ring 031 <i>Anello camma 031</i>	Hubring 031 <i>Aro volumetrico 031</i>	Came 031	A	034.59135	034.59135	1
	Cam ring 035 <i>Anello camma 035</i>	Hubring 035 <i>Aro volumetrico 035</i>	Came 035	A	034.59137	034.59137	1
	Cam ring 038 <i>Anello camma 038</i>	Hubring 038 <i>Aro volumetrico 038</i>	Came 038	A	034.59139	034.59139	1
	Cam ring 042 <i>Anello camma 042</i>	Hubring 042 <i>Aro volumetrico 042</i>	Came 042	A	034.59132	034.59132	1
	Cam ring 045 <i>Anello camma 045</i>	Hubring 045 <i>Aro volumetrico 045</i>	Came 045	A	034.59131	034.59131	1
Cam ring 050 <i>Anello camma 050</i>	Hubring 050 <i>Aro volumetrico 050</i>	Came 050	A	034.66737	034.66737	1	
4	Pin-vane holdout <i>Pistoncino di sostentamento</i>	Stössel <i>Espiga empuje paleta</i>	Poussoir de palette	A	034.59130	034.24984	10
5	Vane <i>Paletta</i>	Flügel <i>Paleta</i>	Palette	A	034.53588	034.53588	10
6	Sq. section seal <i>Guarnizione</i>	Dichtring <i>Junta seccion cuadrada</i>	Joint section carrée	AB	671.10159	671.10159	1
7	Back-up ring <i>Anello anti-estrusione</i>	Stützring <i>Anillo</i>	Bague anti-extrusion	AB	618.00011.3	618.00011.3	1
8	Sq. section seal <i>Guarnizione</i>	Dichtring <i>Junta seccion cuadrada</i>	Joint section carrée	AB	691.10244	691.10244	1
9	Retaining ring <i>Anello elastico</i>	Sicherungsring <i>Anillo de retención</i>	Circlips		356.32283	356.32283	1
10	Ball bearing <i>Cuscinetto a sfera</i>	Kugellager <i>Cojinete de bolas</i>	Roulement à billes	CD EF	230.00207	230.00207	1

Item Pos. Ref. Pos. Pos.	Description <i>Descrizione</i>	Benennung <i>Descripcion</i>	Description		Part N° Teil Nr. Code N° Cod. N° Referencia T6D	Part N° Teil Nr. Code N° Cod. N° Referencia T6DM - T6DP	Qty Stück Qté Q.tà Cant.
11	Mounting cap (standard) (T6D-T6DM) <i>Coperchio (standard) (T6D-T6DM)</i>	Deckel (Standard) (T6D-T6DM) <i>Tapa de montage (estandar) (T6D-T6DM)</i>	Chapeau de montage (standard) (T6D-T6DM)		034.47916	034.47916	1
11b	Mounting cap (standard) (T6DP) <i>Coperchio (standard) (T6DP)</i>	Deckel (Standard) (T6DP) <i>Tapa de montage (estandar) (T6DP)</i>	Chapeau de montage (standard) (T6DP)			034.66725	1
12a	Key (code 2) <i>Chiavetta (codice 2)</i>	Paßfeder (Typ 2) <i>Chaveta (codigo 2)</i>	Clavette (code 2)	D	034.49676	034.49676	1
12b	Key (code 1) <i>Chiavetta (codice 1)</i>	Paßfeder (Typ 1) <i>Chaveta (codigo 1)</i>	Clavette (code 1)	C	034.46754	034.46754	1
13a	Shaft (keyed) (code 2) <i>Albero a chiavetta (codice 2)</i>	Paßfederwelle (Typ 2) <i>Eje chaveteado (codigo 2)</i>	Arbre à clavette (code 2)	D	034.70980	034.70980	1
13b	Shaft (keyed) (code 1) <i>Albero a chiavetta (codice 1)</i>	Paßfederwelle (Typ 1) <i>Eje chaveteado (codigo 1)</i>	Arbre à clavette (code 1)	C	034.70858	034.70858	1
13c	Shaft (splined) (code 3) (T6D-T6DM) <i>Albero scanalato (codice 3) (T6D-T6DM)</i>	Vielkeilwelle (Typ 3) (T6D-T6DM) <i>Eje estriado (codigo 3) (T6D-T6DM)</i>	Arbre à cannelures (code 3) (T6D-T6DM)	E	034.70859	034.70859	1
13d	Shaft (splined) (code 4) <i>Albero scanalato (codice 4)</i>	Vielkeilwelle (Typ 4) <i>Eje estriado (codigo 4)</i>	Arbre à cannelures (code 4)	F	034.70923	034.70923	1
13e	Shaft (splined) (code 3) (T6DP) <i>Albero scanalato (codice 3) (T6DP)</i>	Vielkeilwelle (Typ 3) (T6DP) <i>Eje estriado (codigo 3) (T6DP)</i>	Arbre à cannelures (code 3) (T6DP)	E		034.66724	1
14	Round section ring <i>Anello</i>	Sicherungsring <i>Anillo tórico</i>	Anneau	CD EF	034.70853	034.70853	2
15	Shaft seal (S1 - 0,7 bar) (T6D-T6DM) <i>Paraolio (S1 - 0,7 bar) (T6D-T6DM)</i>	Simmerring (S1 - 0,7 bar) (T6D-T6DM) <i>Reten eje (S1 - 0,7 bar) (T6D-T6DM)</i>	Joint d'arbre (S1 - 0,7 bar) (T6D-T6DM)	B	620.82062	620.82062	1
	Shaft seal (S1 - 0,7 bar) (T6DP) <i>Paraolio (S1 - 0,7 bar) (T6DP)</i>	Simmerring (S1 - 0,7 bar) (T6DP) <i>Reten eje (S1 - 0,7 bar) (T6DP)</i>	Joint d'arbre (S1 - 0,7 bar) (T6DP)	B		620.82062	2
	Shaft seal (S4 - S5 - 7 bar) <i>Paraolio (S4 - S5 - 7 bar)</i>	Simmerring (S4 - S5 - 7 bar) <i>Reten eje (S4 - S5 - 7 bar)</i>	Joint d'arbre (S4 - S5 - 7 bar)		620.82066	620.82066	1
16	Sq. section seal <i>Guarnizione</i>	Dichtring <i>Junta seccion cuadrada</i>	Joint section carrée	AB	691.10232	691.10232	1
17	Port plate-pressure C.C.W. <i>Piatto distributore anter. antioraria</i>	Steuerplatte Linkslauf <i>Plato distribuidor-presión giro I</i>	Plaque pression rotation gauche	A	034.67113		1
	Port plate-pressure C.W. <i>Piatto distributore anter. oraria</i>	Steuerplatte Rechtslauf <i>Plato distribuidor-presión giro D</i>	Plaque pression rotation droite	A	034.67111		1
	Port plate-pressure <i>Piatto distributore anter.</i>	Steuerplatte <i>Plato distribuidor-presión</i>	Plaque pression	A		034.59057	1
18	Rotor-insert ass'y <i>Insieme rotore</i>	Rotor <i>Conjunto rotor</i>	Rotor et douille ass.	A	S24.10121	S24.30018	1
19	Dowel pin <i>Spina</i>	Zentrierstift <i>Pasador</i>	Goupille	A	324.21612	324.21612	2
20	Screw <i>Vite</i>	Schraube <i>Tornille</i>	Vis	A	317.10320	317.10320	2
21	Dowel pin <i>Spina</i>	Zentrierstift <i>Pasador</i>	Goupille	AG HJ	323.82004	323.82004	1

Item Pos. Ref. Pos. Pos.	Description <i>Descrizione</i>	Benennung <i>Descripcion</i>	Description		Part N° Teil Nr. Code N° Cod. N° Referencia T6D	Part N° Teil Nr. Code N° Cod. N° Referencia T6DM - T6DP	Qty Stück Qté Q.tà Cant.
22	Bush <i>Bussola</i>	Buchse <i>Cojinete de fricción</i>	Bague	AG HJ	034.70868	034.70868	1
23	Screw <i>Vite</i>	Schraube <i>Tornille</i>	Vis		306.40157	306.40157	4
24	Retaining ring (T6DP) <i>Anello elastico (T6DP)</i>	Sicherungsring (T6DP) <i>Anillo de retención (T6DP)</i>	Circlips (T6DP)			356.00032.3	1
	REPAIR KIT KIT DI RICAMBIO	AUSTAUSCH-BAUGRUPPEN CONJUNTO REPARACION	POCHETTES RECHANGES				
A	Cart. and plate ass'y *14 C.W. <i>Ins. cart. *14 oraria</i>	Pumpeneinheit *14 Rechtslauf <i>Conjunto cart. y platos *14 giro d.</i>	Cart. et plaque ass. *14 rot. d.		S24.33849	S24.40789	1
A	Cart. and plate ass'y *14 C.C.W. <i>Ins. cart. *14 antioraria</i>	Pumpeneinheit *14 Linkslauf <i>Conjunto cart. y platos *14 giro i.</i>	Cart. et plaque ass. *14 rot. g.		S24.40598	S24.40790	1
A	Cart. and plate ass'y *17 C.W. <i>Ins. cart. *17 oraria</i>	Pumpeneinheit *17 Rechtslauf <i>Conjunto cart. y platos *17 giro d.</i>	Cart. et plaque ass. *17 rot. d.		S24.58996	S24.63325	1
A	Cart. and plate ass'y *17 C.C.W. <i>Ins. cart. *17 antioraria</i>	Pumpeneinheit *17 Linkslauf <i>Conjunto cart. y platos *17 giro i.</i>	Cart. et plaque ass. *17 rot. g.		S24.58997	S24.64242	1
A	Cart. and plate ass'y *20 C.W. <i>Ins. cart. *20 oraria</i>	Pumpeneinheit *20 Rechtslauf <i>Conjunto cart. y platos *20 giro d.</i>	Cart. et plaque ass. *20 rot. d.		S24.26486	S24.30139	1
A	Cart. and plate ass'y *20 C.C.W. <i>Ins. cart. *20 antioraria</i>	Pumpeneinheit *20 Linkslauf <i>Conjunto cart. y platos *20 giro i.</i>	Cart. et plaque ass. *20 rot. g.		S24.26487	S24.30140	1
A	Cart. and plate ass'y *24 C.W. <i>Ins. cart. *24 oraria</i>	Pumpeneinheit *24 Rechtslauf <i>Conjunto cart. y platos *24 giro d.</i>	Cart. et plaque ass. *24 rot. d.		S14.97784	S24.30141	1
A	Cart. and plate ass'y *24 C.C.W. <i>Ins. cart. *24 antioraria</i>	Pumpeneinheit *24 Linkslauf <i>Conjunto cart. y platos *24 giro i.</i>	Cart. et plaque ass. *24 rot. g.		S24.25544	S24.30142	1
A	Cart. and plate ass'y *28 C.W. <i>Ins. cart. *28 oraria</i>	Pumpeneinheit *28 Rechtslauf <i>Conjunto cart. y platos *28 giro d.</i>	Cart. et plaque ass. *28 rot. d.		S24.10837	S24.30143	1
A	Cart. and plate ass'y *28 C.C.W. <i>Ins. cart. *28 antioraria</i>	Pumpeneinheit *28 Linkslauf <i>Conjunto cart. y platos *28 giro i.</i>	Cart. et plaque ass. *28 rot. g.		S24.10838	S24.30144	1
A	Cart. and plate ass'y *31 C.W. <i>Ins. cart. *31 oraria</i>	Pumpeneinheit *31 Rechtslauf <i>Conjunto cart. y platos *31 giro d.</i>	Cart. et plaque ass. *31 rot. d.		S24.10839	S24.30145	1
A	Cart. and plate ass'y *31 C.C.W. <i>Ins. cart. *31 antioraria</i>	Pumpeneinheit *31 Linkslauf <i>Conjunto cart. y platos *31 giro i.</i>	Cart. et plaque ass. *31 rot. g.		S24.10840	S24.30146	1
A	Cart. and plate ass'y *35 C.W. <i>Ins. cart. *35 oraria</i>	Pumpeneinheit *35 Rechtslauf <i>Conjunto cart. y platos *35 giro d.</i>	Cart. et plaque ass. *35 rot. d.		S24.10841	S24.30147	1
A	Cart. and plate ass'y *35 C.C.W. <i>Ins. cart. *35 antioraria</i>	Pumpeneinheit *35 Linkslauf <i>Conjunto cart. y platos *35 giro i.</i>	Cart. et plaque ass. *35 rot. g.		S24.10842	S24.30148	1
A	Cart. and plate ass'y *38 C.W. <i>Ins. cart. *38 oraria</i>	Pumpeneinheit *38 Rechtslauf <i>Conjunto cart. y platos *38 giro d.</i>	Cart. et plaque ass. *38 rot. d.		S24.10843	S24.30149	1
A	Cart. and plate ass'y *38 C.C.W. <i>Ins. cart. *38 antioraria</i>	Pumpeneinheit *38 Linkslauf <i>Conjunto cart. y platos *38 giro i.</i>	Cart. et plaque ass. *38 rot. g.		S24.10844	S24.30150	1
A	Cart. and plate ass'y *42 C.W. <i>Ins. cart. *42 oraria</i>	Pumpeneinheit *42 Rechtslauf <i>Conjunto cart. y platos *42 giro d.</i>	Cart. et plaque ass. *42 rot. d.		S24.10845	S24.30151	1

Item Pos. Ref. Pos. Pos.	Description <i>Descrizione</i>	Benennung <i>Descripcion</i>	Description	Part N° Teil Nr. Code N° Cod. N° Referencia T6D	Part N° Teil Nr. Code N° Cod. N° Referencia T6DM - T6DP	Qty Stück Qté Q.tà Cant.
A	Cart. and plate ass'y *42 C.C.W. <i>Ins. cart. *42 antioraria</i>	Pumpeneinheit *42 Linkslauf <i>Conjunto cart. y platos *42 giro i.</i>	Cart. et plaque ass. *42 rot. g.	S24.10846	S24.30152	1
A	Cart. and plate ass'y *45 C.C.W. <i>Ins. cart. *45 oraria</i>	Pumpeneinheit *45 Rechtslauf <i>Conjunto cart. y platos *45 giro d.</i>	Cart. et plaque ass. *45 rot. d.	S24.10847	S24.30153	1
A	Cart. and plate ass'y *45 C.C.W. <i>Ins. cart. *45 antioraria</i>	Pumpeneinheit *45 Linkslauf <i>Conjunto cart. y platos *45 giro i.</i>	Cart. et plaque ass. *45 rot. g.	S24.10848	S24.30154	1
A	Cart. and plate ass'y *50 C.C.W. <i>Ins. cart. *50 oraria</i>	Pumpeneinheit *50 Rechtslauf <i>Conjunto cart. y platos *50 giro d.</i>	Cart. et plaque ass. *50 rot. d.	S24.40028	S24.40030	1
A	Cart. and plate ass'y *50 C.C.W. <i>Ins. cart. *50 antioraria</i>	Pumpeneinheit *50 Linkslauf <i>Conjunto cart. y platos *50 giro i.</i>	Cart. et plaque ass. *50 rot. g.	S24.40029	S24.40031	1
B	Seal kit (S1 - 0,7 bar) (T6D-T6DM) <i>Serie guarnizioni (S1 - 0,7 bar) (T6D-T6DM)</i>	Dichtringsatz (S1 - 0,7 bar) (T6D-T6DM) <i>Juego de juntas (S1 - 0,7 bar) (T6D-T6DM)</i>	Pochette de joint (S1 - 0,7 bar) (T6D-T6DM)	S24.10138	S24.10138	1
	Seal kit (S1 - 0,7 bar) (T6DP) <i>Serie guarnizioni (S1 - 0,7 bar) (T6DP)</i>	Dichtringsatz (S1 - 0,7 bar) (T6DP) <i>Juego de juntas (S1 - 0,7 bar) (T6DP)</i>	Pochette de joint (S1 - 0,7 bar) (T6DP)		S24.30155	1
	Seal kit (S4 - 7 bar) <i>Serie guarnizioni (S4 - 7 bar)</i>	Dichtringsatz (S4 - 7 bar) <i>Juego de juntas (S4 - 7 bar)</i>	Pochette de joint (S4 - 7 bar)	S24.10138.4	S24.10138.4	1
	Seal kit (S5 - 7 bar) <i>Serie guarnizioni (S5 - 7 bar)</i>	Dichtringsatz (S5 - 7 bar) <i>Juego de juntas (S5 - 7 bar)</i>	Pochette de joint (S5 - 7 bar)	S24.10138.5	S24.10138.5	1
C	Shaft and bearing ass'y (code 1) <i>Ins. albero (codice 1)</i>	Baugruppe (Welle u. Lager) (Typ 1) <i>Conjunto eje cojinete (codigo 1)</i>	Arbre et roulement ass. (code 1)	S14.20084	S14.20084	1
D	Shaft and bearing ass'y (code 2) <i>Ins. albero (codice 2)</i>	Baugruppe (Welle u. Lager) (Typ 2) <i>Conjunto eje cojinete (codigo 2)</i>	Arbre et roulement ass. (code 2)	S14.25646	S14.25646	1
E	Shaft and bearing ass'y (code 3) (T6D-T6DM) <i>Ins. albero (codice 3) (T6D-T6DM)</i>	Baugruppe (Welle u. Lager) (Typ 3) (T6D-T6DM) <i>Conjunto eje cojinete (codigo 3) (T6D-T6DM)</i>	Arbre et roulement ass. (code 3) (T6D-T6DM)	S14.20085	S14.20085	1
	Shaft and bearing ass'y (code 3) (T6DP) <i>Ins. albero (codice 3) (T6DP)</i>	Baugruppe (Welle u. Lager) (Typ 3) (T6DP) <i>Conjunto eje cojinete (codigo 3) (T6DP)</i>	Arbre et roulement ass. (code 3) (T6DP)		S24.30160	1
F	Shaft and bearing ass'y (code 4) <i>Ins. albero (codice 4)</i>	Baugruppe (Welle u. Lager) (Typ 4) <i>Conjunto eje cojinete (codigo 4)</i>	Arbre et roulement ass. (code 4)	S14.40835	S14.40835	1
G	Port plate-rear and bush ass'y C.C.W. <i>Ins. piatto distributore post. antioraria</i>	Steuerplatte mit Buchse Linkslauf <i>Conj. plato dist. tras. con coj. fricción giro I</i>	Plaque ar. et bague ass. rot. gauche	S24.63710		1
H	Port plate-rear and bush ass'y C.C.W. <i>Ins. piatto distributore post. oraria</i>	Steuerplatte mit Buchse Rechtslauf <i>Conj. plato dist. tras. con coj. fricción giro D</i>	Plaque ar. et bague ass. rot. droite	S24.63709		1
J	Port plate-rear and bush ass'y <i>Ins. piatto distributore post.</i>	Steuerplatte mit Buchse <i>Conj. plato dist. tras. con coj. fricción</i>	Plaque ar. et bague ass.		S24.10122	1

Model Code**Typenschlüssel****Designation - type****T6D INDUSTRIAL****Model number :****Typenbezeichnung :****Numéro du modèle :****T6D . - 045 - 1 R 00 - B 1 ..****Series** _____**Baureihe** _____**Série** _____

One letter can be added to specify special parts in series _____

Optionen _____

Une lettre peut être ajoutée pour spécifier les pièces spéciales dans la série. _____

Cam ring _____**geom. Fördervolumen (Flügelzellenpumpe)** _____**Came** _____

(delivery at 0 bar - 1500 rpm)

(Förderstrom bei 0 bar - 1500 U/min)

(débit 0 bar - 1500 tr/min)

014 = 71,4 l/min

035 = 166,5 l/min

020 = 99,0 l/min

038 = 180,4 l/min

024 = 119,3 l/min

042 = 204,0 l/min

028 = 134,5 l/min

045 = 218,5 l/min

031 = 147,4 l/min

050 = 237,0 l/min

Type of shaft _____**Art der Welle** _____**Type d'arbre** _____

1 = keyed (SAE C)

1 = Paßfederwelle (SAE C)

1 = à clavette (SAE C)

2 = keyed (no SAE)

2 = Paßfederwelle (nicht SAE)

2 = à clavette (non SAE)

3 = splined (SAE C)

3 = Vielkeilwelle (SAE C)

3 = à cannelures (SAE C)

4 = splined (no SAE)

4 = Vielkeilwelle (nicht SAE)

4 = à cannelures (non SAE)

Direction of rotation _____**Drehrichtung** _____**Sens de rotation** _____

R = Clockwise

R = Rechtslauf

R = à droite

L = Counter-clockwise

L = Linkslauf

L = à gauche

Porting combination _____**Lage der Anschlüsse** _____**Combinaison des orifices** _____

00 = standard

00 = standard

00 = standard

Design letter _____**Ausführungsbuchstabe** _____**Conception** _____**Seal class** _____**Dichtungs-klasse** _____**Classe de joint** _____

1 = S1 - BUNA N

1 = S1 - BUNA N

1 = S1 - BUNA N

4 = S4 - EPDM

4 = S4 - EPDM

4 = S4 - EPDM

5 = S5 - VITON

5 = S5 - VITON

5 = S5 - VITON

Modifications _____**Modifikationen** _____**Modifications** _____

Designazione

Clave de designación

T6D INDUSTRIAL

Sigla :

Referencia modelo :

T6D . - 045 - 1 R 00 - B 1 ..

Serie _____

Serie _____

Una lettera può essere aggiunta per specificare parti speciali nella serie

Una letra puede ser añadida para especificar piezas especiales en la serie

Tipo di cartuccia _____

(Portata a 0 bar e 1500 g/min)

014 = 71,4 l/min
020 = 99,0 l/min
024 = 119,3 l/min
028 = 134,5 l/min
031 = 147,4 l/min

Aro volumetrico _____

(Caudal 0 bar - 1500 rpm)

035 = 166,5 l/min
038 = 180,4 l/min
042 = 204,0 l/min
045 = 218,5 l/min
050 = 237,0 l/min

Tipo di albero _____

1 = a chiavetta (SAE C)
2 = a chiavetta
3 = scanalato (SAE C)
4 = scanalato

Tipo de eje _____

1 = chaveteado (SAE C)
2 = chaveteado (no SAE)
3 = estriado (SAE C)
4 = estriado (no SAE)

Senso di rotazione _____

R =orario
L = Antiorario

Sentido de giro _____

R = Derecha
L = Izquierda

Orientamento delle bocche _____

00 = standard

Posición de bocas _____

00 = estándar

Diseño _____

Letra de diseño _____

Tipo di guarnizioni _____

1 = S1 - BUNA N
4 = S4 - EPDM
5 = S5 - VITON

Clase de juntas _____

1 = S1 - BUNA N
4 = S4 - EPDM
5 = S5 - VITON

Modifiche _____

Modificaciones _____

Model Code

Typenschlüssel

Designation - type

T6D MOBILE

Model number :

Typenbezeichnung :

Numéro du modèle :

T6D* . - B45 - 1 R 00 - C 1 ..

Series M = Mobile 1 shaft seal
Series P = Mobile 2 shaft seals

Version M = Mobil, 1 Wellendichtung
Version P = Mobil, 2 Wellendichtung

Série M = Mobile 1 joint d'arbre
Série P = Mobile 2 joints d'arbre

One letter can be added to specify special parts in series

Optionen

Une lettre peut être ajoutée pour spécifier les pièces spéciales dans la série.

Cam ring
(delivery at 0 bar - 1500 rpm)
B14 = 71,4 l/min
B20 = 99,0 l/min
B24 = 119,3 l/min
B28 = 134,5 l/min
B31 = 147,4 l/min

geom. Fördervolumen (Flügelzellenpumpe)
(Förderstrom bei 0 bar - 1500 U/min)
B35 = 166,5 l/min
B38 = 180,4 l/min
B42 = 204,0 l/min
B45 = 218,5 l/min
B50 = 237,0 l/min

Came
(débit 0 bar - 1500 tr/min)

Type of shaft - M version
1 = keyed (SAE C)
2 = keyed (no SAE)
3 = splined (SAE C)
4 = splined (no SAE)

Art der Welle - Version M
1 = Paßfederwelle (SAE C)
2 = Paßfederwelle (nicht SAE)
3 = Vielkeilwelle (SAE C)
4 = Vielkeilwelle (nicht SAE)

Type d'arbre - Version M
1 = à clavette (SAE C)
2 = à clavette (non SAE)
3 = à cannelures (SAE C)
4 = à cannelures (non SAE)

Type of shaft - M versioP
3 = splined (no SAE)

Art der Welle - Version P
3 = Vielkeilwelle (nicht SAE)

Type d'arbre - Version P
3 = à cannelures (non SAE)

Direction of rotation
R = Clockwise
L = Counter-clockwise

Drehrichtung
R = Rechtslauf
L = Linkslauf

Sens de rotation
R = à droite
L = à gauche

Porting combination
00 = standard

Lage der Anschlüsse
00 = standard

Combinaison des orifices
00 = standard

Design letter

Ausführungsbuchstabe

Conception

Seal class
1 = S1 - BUNA N
4 = S4 - EPDM
5 = S5 - VITON

Dichtungsklasse
1 = S1 - BUNA N
4 = S4 - EPDM
5 = S5 - VITON

Classe de joint
1 = S1 - BUNA N
4 = S4 - EPDM
5 = S5 - VITON

Modifications

Modifikationen

Modifications

Designazione

Clave de designación

T6D MOBILE

Sigla :

Referencia modelo :

T6D* . - B45 - 1 R 00 - C 1 ..

Serie _____

Serie M = Movil 1 reten eje _____

Serie P = Movil 2 retenes eje _____

Una lettera può essere aggiunta per specificare parti speciali nella serie _____

Una letra puede ser añadida para especificar piezas especiales en la serie _____

Tipo di cartuccia _____

(Portata a 0 bar e 1500 g/min)

B14 = 71,4 l/min

B20 = 99,0 l/min

B24 = 119,3 l/min

B28 = 134,5 l/min

B31 = 147,4 l/min

Aro volumetrico _____

(Caudal 0 bar - 1500 rpm)

B35 = 166,5 l/min

B38 = 180,4 l/min

B42 = 204,0 l/min

B45 = 218,5 l/min

B50 = 237,0 l/min

Tipo di albero - Versione M _____

1 = a chiavetta (SAE C)

2 = a chiavetta

3 = scanalato (SAE C)

4 = scanalato

Tipo de eje - Version M _____

1 = chaveteado (SAE C)

2 = chaveteado (no SAE)

3 = estriado (SAE C)

4 = estriado (no SAE)

Tipo di albero - Versione P _____

3 = scanalato

Tipo de eje - Version P _____

3 = estriado (no SAE)

Senso di rotazione _____

R =orario

L = Antiorario

Sentido de giro _____

R = Derecha

L = Izquierda

Orientamento delle bocche _____

00 = standard

Posición de bocas _____

00 = estándar

Disegno _____

Letra de diseño _____

Tipo di guarnizioni _____

1 = S1 - BUNA N

4 = S4 - EPDM

5 = S5 - VITON

Clase de juntas _____

1 = S1 - BUNA N

4 = S4 - EPDM

5 = S5 - VITON

Modifiche _____

Modificaciones _____