



Vane pumps Service information

vane-type double pump / Flügelzellen-Doppelpumpe

pompe double à palettes / pompa doppia a palette

tipo bomba de paletas doble

T6CC - T6CCM - T6CCP

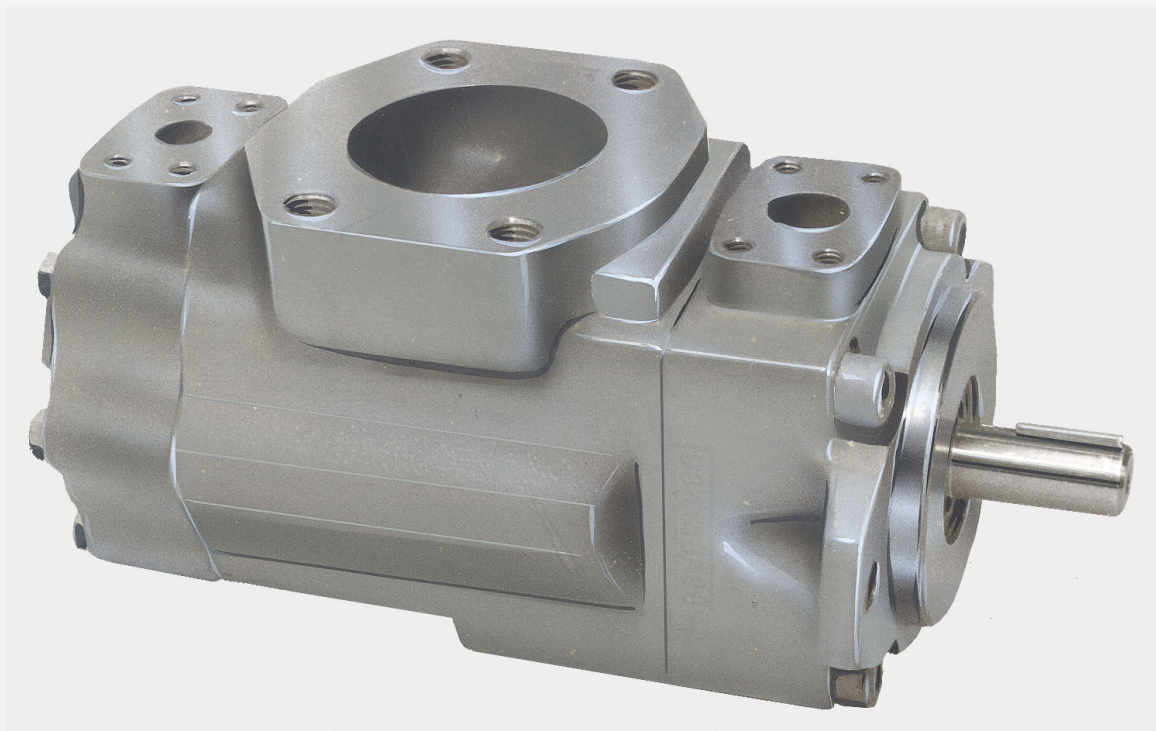

Publ. S1 - ML0505 - A

03 / 2003 / FB

Replaces : S1 - ML 055 - B

L25 - 10505 - 1

DENISON | Hydraulics

Recommended repair kits and assy's are bold printed
 Empfohlene Austausch - Baugruppen sind fett gedruckt
 Les pochettes de rechange recommandées sont imprimées en caractères gras
 I kit di ricambio consigliati sono indicati in grassetto
 Los juegos de reparacion recomendados y los conjuntos, estan en negrita

	Item - Pos. - Réf. - Pos.	
	22	27
Mounting torque		
Anziehdrehmoment	61 Nm	159 Nm
Couple de serrage	45 ft.lbs	117 ft.lbs
Coppia di serragio		
Par de apriete		

T6CC INDUSTRIAL

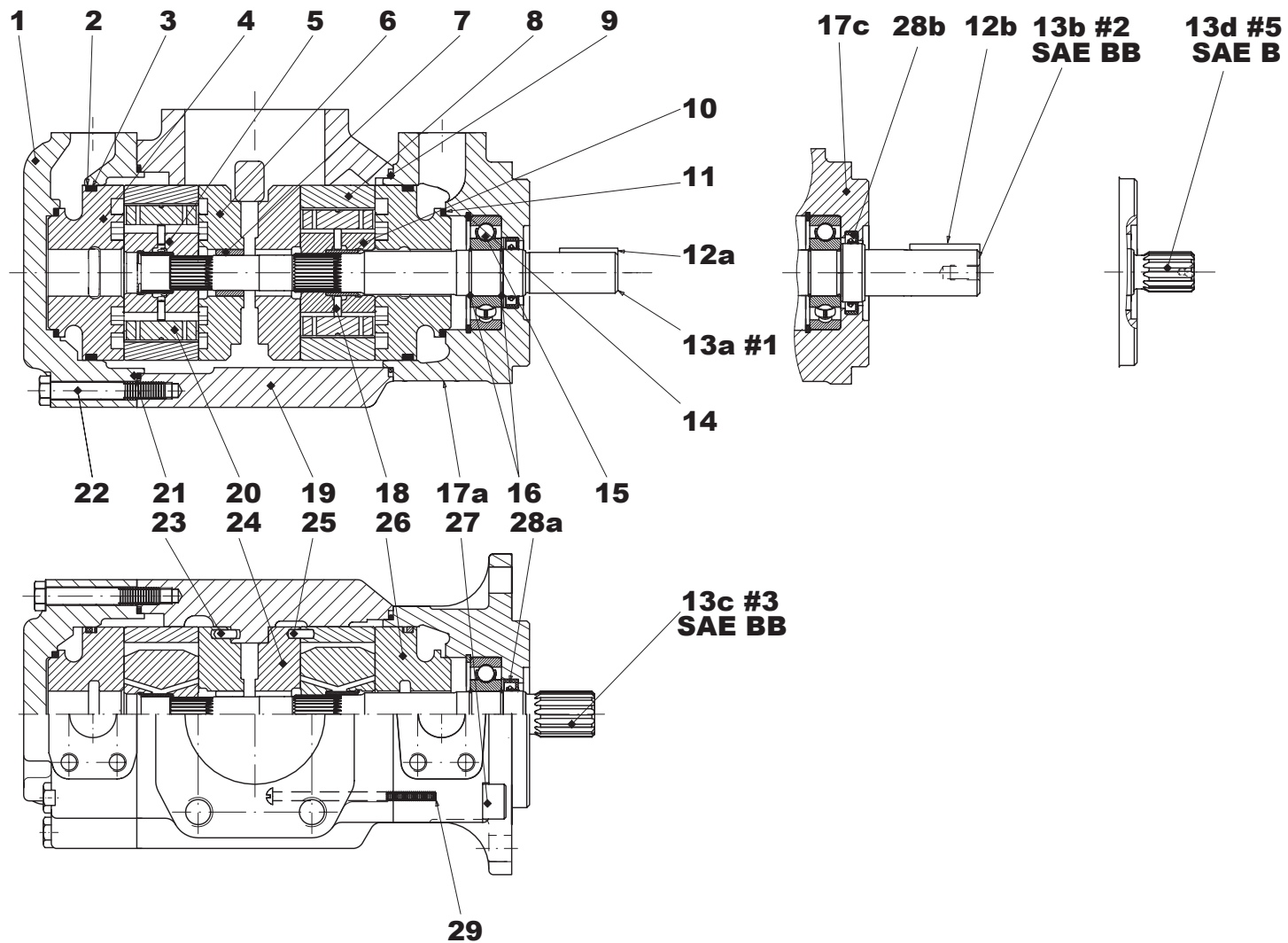

Recommended repair kits and assy's are bold printed
 Empfohlene Austausch - Baugruppen sind fett gedruckt
 Les pochettes de rechange recommandées sont imprimées en caractères gras
 I kit di ricambio consigliati sono indicati in grassetto
 Los juegos de reparacion recomendados y los conjuntos, estan en negrita

	Item - Pos. - Réf. - Pos.	
	22	27
Mounting torque		
Anziehdrehmoment	61 Nm	159 Nm
Couple de serrage	45 ft.lbs	117 ft.lbs
Coppia di serraggio		
Par de apriete		

T6CCM MOBILE

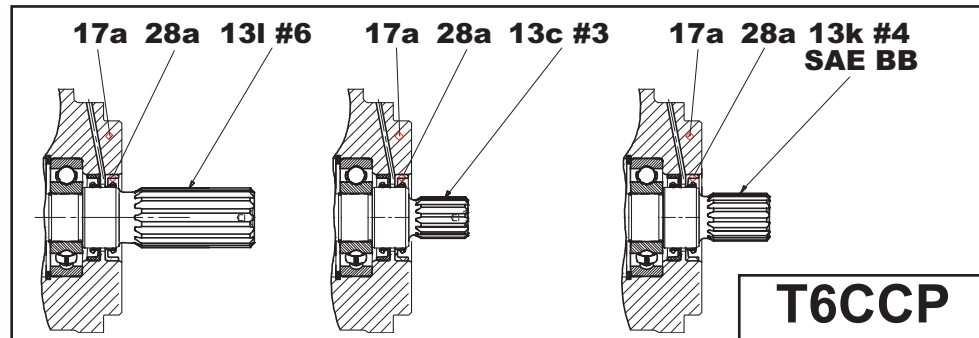
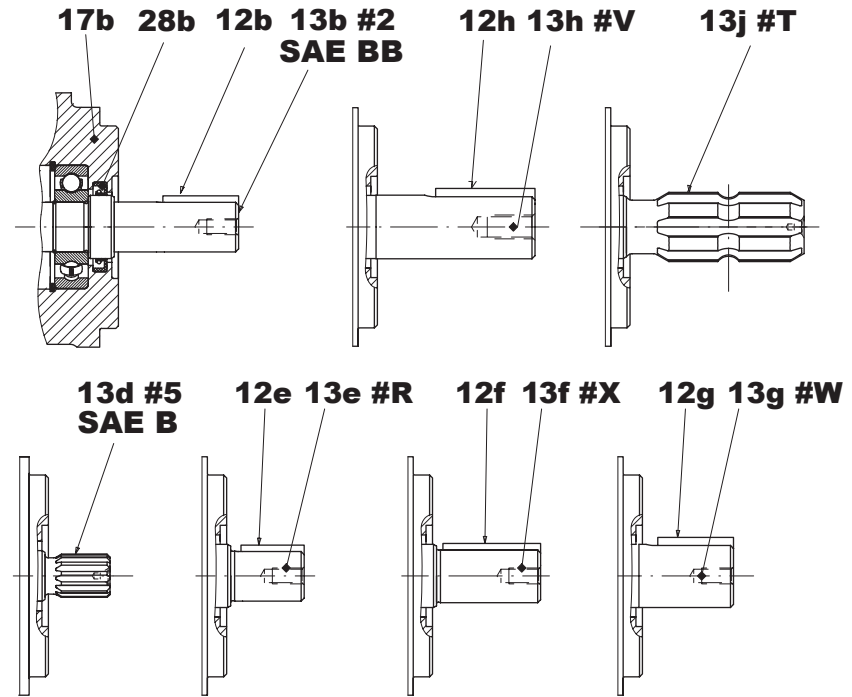
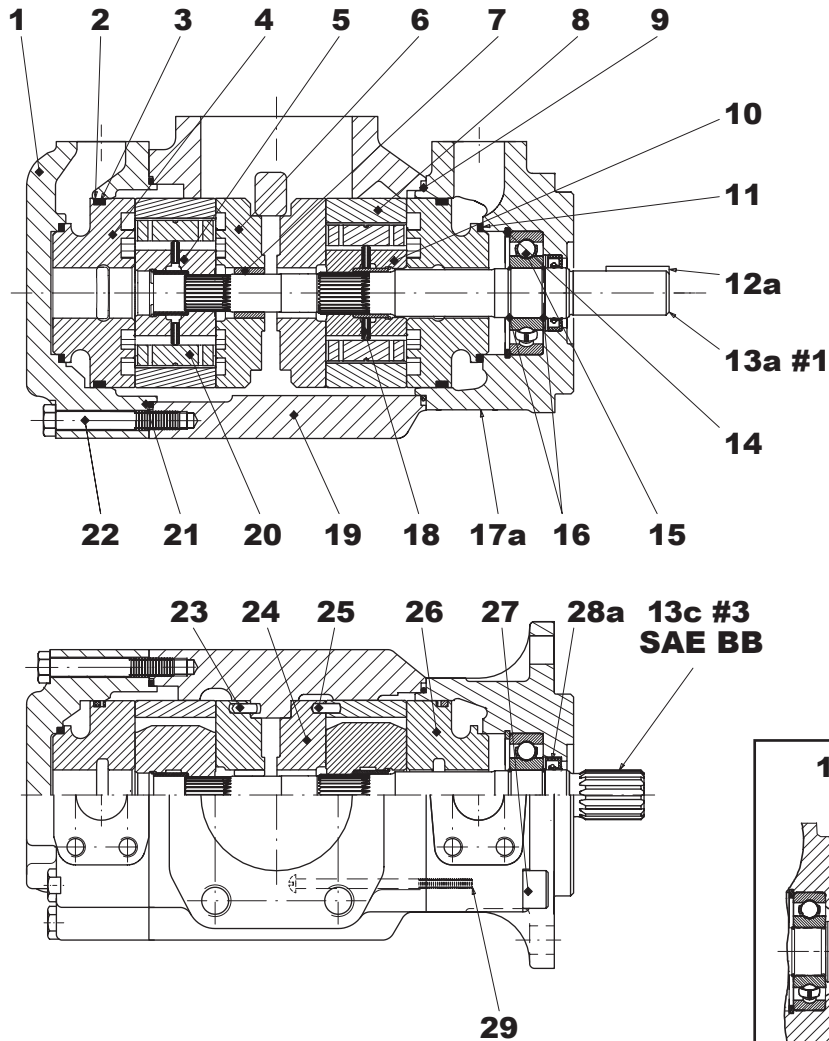

Item Pos. Ref. Pos.	Description Descrizione	Benennung Descripcion	Description		Part N° Teil Nr. Code N° Cod. N° Referencia T6CC	Part N° Teil Nr. Code N° Cod. N° Referencia T6CCM-T6CCP	Qty Stück Qté Q.tà Cant.
1	End cap (UNC) (P2 = 3/4") <i>Coperchio (UNC) (P2 = 3/4")</i>	Deckel (UNC) (P2 = 3/4") <i>Tapa (UNC) (P2 = 3/4")</i>	Chapeau (UNC) (P2 = 3/4")		034.59425	034.59425	1
	End cap (Metric) (P2 = 3/4") <i>Coperchio (Metrica) (P2 = 3/4")</i>	Deckel (Metrisch) (P2 = 3/4") <i>Tapa (Metrico) (P2 = 3/4")</i>	Chapeau (Métrique) (P2 = 3/4")		034.66508	034.66508	1
	End cap (UNC) (P2 = 1") <i>Coperchio (UNC) (P2 = 1")</i>	Deckel (UNC) (P2 = 1") <i>Tapa (UNC) (P2 = 1")</i>	Chapeau (UNC) (P2 = 1")		034.59423	034.59423	1
	End cap (Metric) (P2 = 1") <i>Coperchio (Metrica) (P2 = 1")</i>	Deckel (Metrisch) (P2 = 1") <i>Tapa (Metrico) (P2 = 1")</i>	Chapeau (Métrique) (P2 = 1")		034.66674	034.66674	1
2	Sq. section seal <i>Guarnizione</i>	Dichtring <i>Junta seccion cuadrada</i>	Joint section carrée	AB CD	691.10238	691.10238	2
3	Back-up ring <i>Anello anti-estrusione</i>	Stützring <i>Anillo</i>	<i>Bague anti-extrusion</i>	AB CD	618.00010.3	618.00010.3	2
4	Port plate-pressure C.C.W. <i>Piatto distributore anter. antioraria</i>	Steuerplatte Linkslauf <i>Plato distribuidor-presión giro I</i>	Plaque pression rotation gauche	B	034.59772		1
	Port plate-pressure C.W. <i>Piatto distributore anter. oraria</i>	Steuerplatte Rechtslauf <i>Plato distribuidor-presión giro D</i>	Plaque pression rotation droite	B	034.59773		1
	Port plate-pressure <i>Piatto distributore anter.</i>	Steuerplatte <i>Plato distribuidor-presión</i>	Plaque pression	B		034.66453	1
5	Rotor-insert ass'y <i>Insieme rotore</i>	Rotor <i>Conjunto rotor</i>	Rotor et douille ass.	B	S24.10116	S24.30049	1
6	Port plate-rear C.C.W. <i>Piatto distributore post. antioraria</i>	Steuerplatte Linkslauf <i>Plato distribuidor trasero giro I</i>	Plaque arrière rotation gauche	RB	034.59776		1
	Port plate-rear C.W. <i>Piatto distributore post. oraria</i>	Steuerplatte Rechtslauf <i>Plato distribuidor trasero giro D</i>	Plaque arrière rotation droite	SB	034.59777		1
	Port plate-rear <i>Piatto distributore post.</i>	Steuerplatte <i>Plato distribuidor trasero</i>	Plaque arrière	TB		034.59118	1
7	Bush <i>Bussola</i>	Buchse <i>Cojinete de fricción</i>	Bague	RS TB	034.59412	034.59412	1
8	Cam ring 003 <i>Anello camma 003</i>	Hubring 003 <i>Aro volumetrico 003</i>	Came 003	AB	034.59050	034.59050	2
	Cam ring 005 <i>Anello camma 005</i>	Hubring 005 <i>Aro volumetrico 005</i>	Came 005	AB	034.59051	034.59051	2
	Cam ring 006 <i>Anello camma 006</i>	Hubring 006 <i>Aro volumetrico 006</i>	Came 006	AB	034.59052	034.59052	2
	Cam ring 008 <i>Anello camma 008</i>	Hubring 008 <i>Aro volumetrico 008</i>	Came 008	AB	034.59053	034.59053	2
	Cam ring 010 <i>Anello camma 010</i>	Hubring 010 <i>Aro volumetrico 010</i>	Came 010	AB	034.59054	034.59054	2
	Cam ring 012 <i>Anello camma 012</i>	Hubring 012 <i>Aro volumetrico 012</i>	Came 012	AB	034.66595	034.66595	2
	Cam ring 014 <i>Anello camma 014</i>	Hubring 014 <i>Aro volumetrico 014</i>	Came 014	AB	034.59206	034.59206	2
	Cam ring 017 <i>Anello camma 017</i>	Hubring 017 <i>Aro volumetrico 017</i>	Came 017	AB	034.59207	034.59207	2

Item Pos. Ref. Pos. Pos.	Description <i>Descrizione</i>	Benennung <i>Descripcion</i>	Description		Part N° Teil Nr. Code N° Cod. N° Referencia T6CC	Part N° Teil Nr. Code N° Cod. N° Referencia T6CCM-T6CCP	Qty Stück Qté Q.tà Cant.
8	Cam ring 020 <i>Anello camma 020</i>	Hubring 020 <i>Aro volumetrico 020</i>	Came 020	AB	034.66607	034.66607	2
	Cam ring 022 <i>Anello camma 020</i>	Hubring 022 <i>Aro volumetrico 022</i>	Came 022	AB	034.59208	034.59208	2
	Cam ring 025 <i>Anello camma 025</i>	Hubring 025 <i>Aro volumetrico 025</i>	Came 025	AB	034.59209	034.59209	2
	Cam ring 028 <i>Anello camma 028</i>	Hubring 028 <i>Aro volumetrico 028</i>	Came 028	AB	034.59245	034.59245	2
	Cam ring 031 <i>Anello camma 031</i>	Hubring 031 <i>Aro volumetrico 031</i>	Came 031	AB	034.66843	034.66843	2
9	O.ring <i>Guarnizione</i>	Dichtring <i>Guarnizione torica</i>	Joint torique	ACD	671.00244	671.00244	1
10	Rotor-insert ass'y <i>Insieme rotore</i>	Rotor <i>Conjunto rotor</i>	Rotor et douille ass.	A	S24.10350	S24.33974	1
11	Sq. section seal <i>Guarnizione</i>	Dichtring <i>Junta seccion cuadrada</i>	Joint section carrée	AB CD	691.10229	691.10229	2
12a	Key (code 1) <i>Chiavetta (codice 1)</i>	Paßfeder (Typ 1) <i>Chaveta (codigo 1)</i>	Clavette (code 1)	E	034.49622	034.49622	1
12b	Key (code 2) <i>Chiavetta (codice 2)</i>	Paßfeder (Typ 2) <i>Chaveta (codigo 2)</i>	Clavette (code 2)	F	034.48690	034.48690	1
12e	Key (code R) <i>Chiavetta (codice R)</i>	Paßfeder (Typ R) <i>Chaveta (codigo R)</i>	Clavette (code R)	J		034.66717	1
12f	Key (code X) <i>Chiavetta (codice X)</i>	Paßfeder (Typ X) <i>Chaveta (codigo X)</i>	Clavette (code X)	K		034.19579	1
12g	Key (code W) <i>Chiavetta (codice W)</i>	Paßfeder (Typ W) <i>Chaveta (codigo W)</i>	Clavette (code W)	L		034.49676	1
12h	Key (code V) <i>Chiavetta (codice V)</i>	Paßfeder (Typ V) <i>Chaveta (codigo V)</i>	Clavette (code V)	M		034.30168	1
13a	Shaft (keyed) (code 1) <i>Albero a chiavetta (codice 1)</i>	Paßfederwelle (Typ 1) <i>Eje chaveteado (codigo 1)</i>	Arbre à clavette (code 1)	E	034.59110	034.59110	1
13b	Shaft (keyed) (code 2) (SAE BB) (T6CCW) (T6CCMW) <i>Albero a chiavetta (codice 2) (SAE BB) (T6CCW) (T6CCMW)</i>	Paßfederwelle (Typ 2) (SAE BB) (T6CCW) (T6CCMW) <i>Eje chaveteado (codigo 2) (SAE BB) (T6CCW) (T6CCMW)</i>	Arbre à clavette (code 2) (SAE BB) (T6CCW) (T6CCMW)	F	034.66576	034.66576	1
13c	Shaft (splined) (code 3) (SAE BB) (T6CC) (T6CCM) <i>Albero a scanalato (codice 3) (SAE BB) (T6CC) (T6CCM)</i>	Vielkeilwelle (Typ 3) (SAE BB) (T6CC) (T6CCM) <i>Eje estriado (codigo 3) (SAE BB) (T6CC) (T6CCM)</i>	Arbre à cannelures (code 3) (SAE BB) (T6CC) (T6CCM)	G	034.59108	034.59108	1
	Shaft (splined) (code 3) (T6CCP) <i>Albero a scanalato (codice 3) (T6CCP)</i>	Vielkeilwelle (Typ 3) (T6CCP) <i>Eje estriado (codigo 3) (T6CCP)</i>	Arbre à cannelures (code 3) (T6CCP)	G		034.66727	1
13d	Shaft (splined) (code 5) (SAE B) (T6CC) (T6CCM) <i>Albero a scanalato (codice 5) (SAE B) (T6CC) (T6CCM)</i>	Vielkeilwelle (Typ 5) (SAE B) (T6CC) (T6CCM) <i>Eje estriado (codigo 5) (SAE B) (T6CC) (T6CCM)</i>	Arbre à cannelures (code 5) (SAE B) (T6CC) (T6CCM)	H	034.59109	034.59109	1
13e	Shaft (keyed) (code R) (T6CCMW) <i>Albero a chiavetta (codice R) (T6CCMW)</i>	Paßfederwelle (Typ R) (T6CCMW) <i>Eje chaveteado (codigo R) (T6CCMW)</i>	Arbre à clavette (code R) (T6CCMW)	J		034.66712	1
13f	Shaft (keyed) (code X) (T6CCMW) <i>Albero a chiavetta (codice X) (T6CCMW)</i>	Paßfederwelle (Typ X) (T6CCMW) <i>Eje chaveteado (codigo X) (T6CCMW)</i>	Arbre à clavette (code X) (T6CCMW)	K		034.66575	1

Item Pos. Ref. Pos.	Description Descrizione	Benennung Descripcion	Description		Part N° Teil Nr. Code N° Cod. N° Referencia T6CC	Part N° Teil Nr. Code N° Cod. N° Referencia T6CCM-T6CCP	Qty Stück Qté Q.tà Cant.
13g	Shaft (keyed) (code W) (T6CCMW) <i>Albero a chiavetta (codice W) (T6CCMW)</i>	Paßfederwelle (Typ W) (T6CCMW) <i>Eje chaveteado (codigo W) (T6CCMW)</i>	Arbre à clavette (code W) (T6CCMW)	L		034.66590	1
13h	Shaft (keyed) (code V) (T6CCMW) <i>Albero a chiavetta (codice V) (T6CCMW)</i>	Paßfederwelle (Typ V) (T6CCMW) <i>Eje chaveteado (codigo V) (T6CCMW)</i>	Arbre à clavette (code V) (T6CCMW)	M		034.66506	1
13j	Shaft (splined) (code T) (T6CCMW) <i>Albero a scanalato (codice T) (T6CCMW)</i>	Vielkeilwelle (Typ T)(T6CCMW) <i>Eje estriado (codigo T) (T6CCMW)</i>	Arbre à cannelures (code T) (T6CCMW)	N		034.66726	1
13k	Shaft (splined) (code 4) (SAE BB) (T6CCP) <i>Albero a scanalato (codice 4) (SAE BB)(T6CCP)</i>	Vielkeilwelle (Typ 4) (SAE BB) (T6CCP) <i>Eje estriado (codigo 4) (SAE BB)(T6CCP)</i>	Arbre à cannelures (code 4) (SAE BB) (T6CCP)	P		034.67001	1
13l	Shaft (splined) (code 6) (T6CCP) <i>Albero a scanalato (codice 6) (T6CCP)</i>	Vielkeilwelle (Typ 6) (T6CCP) <i>Eje estriado (codigo 6) (T6CCP)</i>	Arbre à cannelures (code 6) (T6CCP)	Q		034.66728	1
14	Retaining ring <i>Anello elastico</i>	Sicherungsring <i>Anillo de retención</i>	Circlips		356.30244	356.30244	1
15	Ball bearing <i>Cuscinetto a sfere</i>	Kugellager <i>Cojinete de bolas</i>	Roulement à billes	E...Q	230.82054	230.82054	1
16	Round section ring (shafts 1-3-5) <i>Anello elastico (albero 1-3-5)</i>	Sicherungsring (Wellen 1-3-5) <i>Anillo tórico (eje 1-3-5)</i>	Anneau (arbres 1-3-5)	F J...N	034.70777	034.70777	2
	Round section ring (shafts 2-R-X-W-V-T) <i>Anello elastico (albero 2-R-X-W-V-T)</i>	Sicherungsring (Wellen 2-R-X-W-V-T) <i>Anillo tórico (eje 2-R-X-W-V-T)</i>	Anneau (arbres 2-R-X-W-V-T)		034.70777	034.70777	1
17a	Mounting cap (UNC) (shafts 1-3-5) <i>Coperchio anteriore (UNC) (albero 1-3-5)</i>	Deckel (UNC) (Wellen 1-3-5) <i>Tapa de montaje (UNC) (eje 1-3-5)</i>	Chapeau de montage (UNC) (arbres 1-3-5)		034.59107	034.59107	1
	Mounting cap (Metric) (shafts 1-3-5) <i>Coperchio anteriore (metrica) (albero 1-3-5)</i>	Deckel (Metrisch) (Wellen 1-3-5) <i>Tapa de montaje (Metrica) (eje 1-3-5)</i>	Chapeau de montage (Métrique) (arbres 1-3-5)		034.66690	034.66690	1
	Mounting cap (standard) (T6CCP) <i>Coperchio anteriore (standard) (T6CCP)</i>	Deckel (Standard) (T6CCP) <i>Tapa de montaje (estandar) (T6CCP)</i>	Chapeau de montage (standard) (T6CCP)			034.66729	1
17b	Mounting cap (UNC) (shafts 2-R-X-W-V-T) <i>Coperchio anteriore (UNC) (albero 2-R-X-W-V-T)</i>	Deckel (UNC) (Wellen 2-R-X-W-V-T) <i>Tapa de montaje (UNC) (eje 2-R-X-W-V-T)</i>	Chap. de mtg. (UNC) (arbres 2-R-X-W-V-T)		034.66579	034.66579	1
	Mounting cap (Metric) (shafts 2-R-X-W-V-T) <i>Coperchio anteriore (metrica) (albero 2-R-X-W-V-T)</i>	Deckel (Metrisch) (Wellen 2-R-X-W-V-T) <i>Tapa de montaje (Metrica) (eje 2-R-X-W-V-T)</i>	Chap. de mtg. (Métrique) (arbres 2-R-X-W-V-T)		034.66507	034.66507	1
18	Pin-vane holdout <i>Pistoncino di sostentamento</i>	Stößel <i>Espiga emouje paleta</i>	Poussoir de palette	AB	034.59098	034.24982	20
19	Housing (UNC) (S = 2" 1/2) <i>Corpo (UNC) (S = 2" 1/2)</i>	Gehäuse (UNC) (S = 2" 1/2) <i>Cuerpo (UNC) (S = 2" 1/2)</i>	Carter (UNC) (S = 2" 1/2)		034.59125	034.59125	1
	Housing (Metric) (S = 2" 1/2) <i>Corpo (metrica) (S = 2" 1/2)</i>	Gehäuse (Metrisch) (S = 2" 1/2) <i>Cuerpo (Metrica) (S = 2" 1/2)</i>	Carter (Métrique) (S = 2" 1/2)		034.66509	034.66509	1
	Housing (UNC) (S = 3") <i>Corpo (UNC) (S = 3")</i>	Gehäuse (UNC) (S = 3") <i>Cuerpo (UNC) (S = 3")</i>	Carter (UNC) (S = 3")		034.59105	034.59105	1
	Housing (Metric) (S = 3") <i>Corpo (UNC) (S = 3")</i>	Gehäuse (Metrisch) (S = 3") <i>Cuerpo (Metrica) (S = 3")</i>	Carter (Métrique) (S = 3")		034.66675	034.66675	1
20	Vane <i>Paletta</i>	Flügel <i>Paleta</i>	Palette	AB	034.59099	034.66716	20
21	Sq. section seal <i>Guarnizione</i>	Dichtring <i>Junta seccion cuadrada</i>	Joint section carrée	BCD	671.10156	671.10156	1
22	Screw <i>Vite</i>	Schraube <i>Tornille</i>	Vis		306.40094	306.40094	7

Item Pos. Ref. Pos. Pos.	Description Descrizione	Benennung Descripcion	Description		Part N° Teil Nr. Code N° Cod. N° Referencia T6CC	Part N° Teil Nr. Code N° Cod. N° Referencia T6CCM-T6CCP	Qty Stück Qté Q.tà Cant.
23	Dowel pin Spina	Zentrierstift Pasador	Goupille	AB R..W	323.82010	323.82010	2
24	Port plate-rear C.C.W. Piatto distributore post. antioraria	Steuerplatte Linkslauf Plato distribuidor trasero giro l	Plaque arrière rotation gauche	AU	034.59777		1
	Port plate-rear C.W. Piatto distributore post. oraria	Steuerplatte Rechtslauf Plato distribuidor trasero giro D	Plaque arrière rotation droite	AV	034.59776		1
	Port plate-rear Piatto distributore post.	Steuerplatte Plato distribuidor trasero	Plaque arrière	AS		034.59118	1
25	Dowel pin Spina	Zentrierstift Pasador	Goupille	AB	324.21208	324.21208	4
26	Port plate-pressure C.C.W. Piatto distributore anter. antioraria	Steuerplatte Linkslauf Plato distribuidor-presión giro l	Plaque pression rotation gauche	A	034.59773		1
	Port plate-pressure C.W. Piatto distributore anter. oraria	Steuerplatte Rechtslauf Plato distribuidor-presión giro D	Plaque pression rotation droite	A	034.59772		1
	Port plate-pressure Piatto distributore anter.	Steuerplatte Plato distribuidor-presión	Plaque pression	A		034.66453	1
27	Screw Vite	Schraube Tornille	Vis		358.20320	358.20320	4
28a	Shaft seal (S1 - 0,7 bar) (shafts 1-3-5) (T6CC - T6CCM) Paraolio (S1 - 0,7 bar) (albero 1-3-5) (T6CC - T6CCM)	Simmerring (S1 - 0,7 bar) (Wellen 1-3-5) (T6CC - T6CCM) Reten eje (S1 - 0,7 bar)(eje 1-3-5) (T6CC - T6CCM)	Joint d'arbre (S1 - 0,7 bar) (arbres 1-3-5) (T6CC - T6CCM)	C	620.82012	620.82012	1
	Shaft seal (S1 - 0,7 bar) (T6CCP) Paraolio (S1 - 0,7 bar) (T6CCP)	Simmerring (S1 - 0,7 bar) (T6CCP) Reten eje (S1 - 0,7 bar) (T6CCP)	Joint d'arbre (S1 - 0,7 bar) (T6CCP)	C		620.82046	2
	Shaft seal (S4 - S5 - 7 bar) (shafts 1-3-5) (T6CC - T6CCM) Paraolio (S4 - S5 - 7 bar) (albero 1-3-5) (T6CC - T6CCM)	Simmerring (S4 - S5 - 7 bar) (Wellen 1-3-5) (T6CC - T6CCM) Reten eje (S4 - S5 - 7 bar) (eje 1-3-5) (T6CC - T6CCM)	Joint d'arbre (S4 - S5 - 7 bar) (arbres 1-3-5) (T6CC - T6CCM)		620.82068	620.82068	1
28b	Shaft seal (S1 - 0,7 bar) (shafts 2-R-X-W-V-T) Paraolio (S1 - 0,7 bar) (albero 2-R-X-W-V-T)	Simmerring (S1 - 0,7 bar) (Wellen 2-R-X-W-V-T) Reten eje (S1 - 0,7 bar) (eje 2-R-X-W-V-T)	Joint d'arbre (S1 - 0,7 bar) (arb.res2-R-X-W-V-T)	D	620.82046	620.82046	1
	Shaft seal (S4 - 0,7 bar) (shafts 2-R-X-W-V-T) Paraolio (S1 - 0,7 bar) (albero 2-R-X-W-V-T)	Simmerring (S4 - 0,7 bar) (Wellen 2-R-X-W-V-T) Reten eje (S4 - 0,7 bar) (eje 2-R-X-W-V-T)	Joint d'arbre (S4 - 0,7 bar) (arbres 2-R-X-W-V-T)		620.82046.4	620.82046.4	1
	Shaft seal (S5 - 0,7 bar) (shafts 2-R-X-W-V-T) Paraolio (S5 - 0,7 bar) (albero 2-R-X-W-V-T)	Simmerring (S5 - 0,7 bar) (Wellen 2-R-X-W-V-T) Reten eje (S5 - 0,7 bar) (eje 2-R-X-W-V-T)	Joint d'arbre (S5 - 0,7 bar) (arbres 2-R-X-W-V-T)		620.82046.5	620.82046.5	1
29	Screw Vite	Schraube Tornille	Vis	AB	317.06266	317.06266	4
	REPAIR KIT KIT DI RICAMBIO	AUSTAUSCH-BAUGRUPPEN CONJUNTO REPARACION	POCHETTES RECHANGES				
A	Cart. and plate ass'y *03 C.W. (P1) Ins. cart. *03 oraria (P1)	Pumpeneinheit *03 Rechtslauf (P1) Conjunto cart. y platos *03 giro d. (P1)	Cart. et plaque ass. *03 rot. d. (P1)		S24.10731	S24.40150	1
A	Cart. and plate ass'y *03 C.C.W. (P1) Ins. cart. *03 antioraria (P1)	Pumpeneinheit *03 Linkslauf (P1) Conjunto cart. y platos *03 giro i. (P1)	Cart. et plaque ass. *03 rot. g. (P1)		S24.10732	S24.40151	1
A	Cart. and plate ass'y *05 C.W. (P1) Ins. cart. *05 oraria (P1)	Pumpeneinheit *05 Rechtslauf (P1) Conjunto cart. y platos *05 giro d. (P1)	Cart. et plaque ass. *05 rot. d. (P1)		S24.10733	S24.40152	1
A	Cart. and plate ass'y *05 C.C.W. (P1) Ins. cart. *05 antioraria (P1)	Pumpeneinheit *05 Linkslauf (P1) Conjunto cart. y platos *05 giro i. (P1)	Cart. et plaque ass. *05 rot. g. (P1)		S24.10734	S24.40153	1

Item Pos. Ref. Pos. Pos.	Description <i>Descrizione</i>	Benennung <i>Descripcion</i>	Description	Part N° Teil Nr. Code N° Cod. N° Referencia T6CC	Part N° Teil Nr. Code N° Cod. N° Referencia T6CCM-T6CCP	Qty Stück Qté Q.tà Cant.
A	Cart. and plate ass'y *06 C.W. (P1) <i>Ins. cart. *06 oraria (P1)</i>	Pumpeneinheit *06 Rechtslauf (P1) <i>Conjunto cart. y platos *06 giro d. (P1)</i>	Cart. et plaque ass. *06 rot. d. (P1)	S24.10735	S24.40154	1
A	Cart. and plate ass'y *06 C.C.W. (P1) <i>Ins. cart. *06 antiioraria (P1)</i>	Pumpeneinheit *06 Linkslauf (P1) <i>Conjunto cart. y platos *06 giro i. (P1)</i>	Cart. et plaque ass. *06 rot. g. (P1)	S24.10736	S24.40155	1
A	Cart. and plate ass'y *08 C.W. (P1) <i>Ins. cart. *08 oraria (P1)</i>	Pumpeneinheit *08 Rechtslauf (P1) <i>Conjunto cart. y platos *08 giro d. (P1)</i>	Cart. et plaque ass. *08 rot. d. (P1)	S24.10737	S24.40156	1
A	Cart. and plate ass'y *08 C.C.W. (P1) <i>Ins. cart. *08 antiioraria (P1)</i>	Pumpeneinheit *08 Linkslauf (P1) <i>Conjunto cart. y platos *08 giro i. (P1)</i>	Cart. et plaque ass. *08 rot. g. (P1)	S24.10738	S24.40157	1
A	Cart. and plate ass'y *10 C.W. (P1) <i>Ins. cart. *10 oraria (P1)</i>	Pumpeneinheit *10 Rechtslauf (P1) <i>Conjunto cart. y platos *10 giro d. (P1)</i>	Cart. et plaque ass. *10 rot. d. (P1)	S24.10739	S24.40158	1
A	Cart. and plate ass'y *10 C.C.W. (P1) <i>Ins. cart. *10 antiioraria (P1)</i>	Pumpeneinheit *10 Linkslauf (P1) <i>Conjunto cart. y platos *10 giro i. (P1)</i>	Cart. et plaque ass. *10 rot. g. (P1)	S24.10740	S24.40159	1
A	Cart. and plate ass'y *12 C.W. (P1) <i>Ins. cart. *12 oraria (P1)</i>	Pumpeneinheit *12 Rechtslauf (P1) <i>Conjunto cart. y platos *12 giro d. (P1)</i>	Cart. et plaque ass. *12 rot. d. (P1)	S24.26509	S24.40160	1
A	Cart. and plate ass'y *12 C.C.W. (P1) <i>Ins. cart. *12 antiioraria (P1)</i>	Pumpeneinheit *12 Linkslauf (P1) <i>Conjunto cart. y platos *12 giro i. (P1)</i>	Cart. et plaque ass. *12 rot. g. (P1)	S24.26510	S24.40161	1
A	Cart. and plate ass'y *14 C.W. (P1) <i>Ins. cart. *14 oraria (P1)</i>	Pumpeneinheit *14 Rechtslauf (P1) <i>Conjunto cart. y platos *14 giro d. (P1)</i>	Cart. et plaque ass. *14 rot. d. (P1)	S24.10741	S24.40162	1
A	Cart. and plate ass'y *14 C.C.W. (P1) <i>Ins. cart. *14 antiioraria (P1)</i>	Pumpeneinheit *14 Linkslauf (P1) <i>Conjunto cart. y platos *14 giro i. (P1)</i>	Cart. et plaque ass. *14 rot. g. (P1)	S24.10742	S24.40163	1
A	Cart. and plate ass'y *17 C.W. (P1) <i>Ins. cart. *17 oraria (P1)</i>	Pumpeneinheit *17 Rechtslauf (P1) <i>Conjunto cart. y platos *17 giro d. (P1)</i>	Cart. et plaque ass. *17 rot. d. (P1)	S24.10743	S24.40164	1
A	Cart. and plate ass'y *17 C.C.W. (P1) <i>Ins. cart. *17 antiioraria (P1)</i>	Pumpeneinheit *17 Linkslauf (P1) <i>Conjunto cart. y platos *17 giro i. (P1)</i>	Cart. et plaque ass. *17 rot. g. (P1)	S24.10744	S24.40165	1
A	Cart. and plate ass'y *20 C.W. (P1) <i>Ins. cart. *20 oraria (P1)</i>	Pumpeneinheit *20 Rechtslauf (P1) <i>Conjunto cart. y platos *20 giro d. (P1)</i>	Cart. et plaque ass. *20 rot. d. (P1)	S24.26853	S24.40166	1
A	Cart. and plate ass'y *20 C.C.W. (P1) <i>Ins. cart. *20 antiioraria (P1)</i>	Pumpeneinheit *20 Linkslauf (P1) <i>Conjunto cart. y platos *20 giro i. (P1)</i>	Cart. et plaque ass. *20 rot. g. (P1)	S24.26854	S24.40167	1
A	Cart. and plate ass'y *22 C.W. (P1) <i>Ins. cart. *22 oraria (P1)</i>	Pumpeneinheit *22 Rechtslauf (P1) <i>Conjunto cart. y platos *22 giro d. (P1)</i>	Cart. et plaque ass. *22 rot. d. (P1)	S24.10745	S24.40168	1
A	Cart. and plate ass'y *22 C.C.W. (P1) <i>Ins. cart. *22 antiioraria (P1)</i>	Pumpeneinheit *22 Linkslauf (P1) <i>Conjunto cart. y platos *22 giro i. (P1)</i>	Cart. et plaque ass. *22 rot. g. (P1)	S24.10746	S24.40169	1
A	Cart. and plate ass'y *25 C.W. (P1) <i>Ins. cart. *25 oraria (P1)</i>	Pumpeneinheit *25 Rechtslauf (P1) <i>Conjunto cart. y platos *25 giro d. (P1)</i>	Cart. et plaque ass. *25 rot. d. (P1)	S24.10747	S24.40170	1
A	Cart. and plate ass'y *25 C.C.W. (P1) <i>Ins. cart. *25 antiioraria (P1)</i>	Pumpeneinheit *25 Linkslauf (P1) <i>Conjunto cart. y platos *25 giro i. (P1)</i>	Cart. et plaque ass. *25 rot. g. (P1)	S24.10748	S24.40171	1
A	Cart. and plate ass'y *28 C.W. (P1) <i>Ins. cart. *28 oraria (P1)</i>	Pumpeneinheit *28 Rechtslauf (P1) <i>Conjunto cart. y platos *28 giro d. (P1)</i>	Cart. et plaque ass. *28 rot. d. (P1)	S24.25510	S24.40172	1
A	Cart. and plate ass'y *28 C.C.W. (P1) <i>Ins. cart. *28 antiioraria (P1)</i>	Pumpeneinheit *28 Linkslauf (P1) <i>Conjunto cart. y platos *28 giro i. (P1)</i>	Cart. et plaque ass. *28 rot. g. (P1)	S14.97738	S24.40173	1
A	Cart. and plate ass'y *31 C.W. (P1) <i>Ins. cart. *31 oraria (P1)</i>	Pumpeneinheit *31 Rechtslauf (P1) <i>Conjunto cart. y platos *31 giro d. (P1)</i>	Cart. et plaque ass. *31 rot. d. (P1)	S24.45787	S24.45793	1
A	Cart. and plate ass'y *31 C.C.W. (P1) <i>Ins. cart. *31 antiioraria (P1)</i>	Pumpeneinheit *31 Linkslauf (P1) <i>Conjunto cart. y platos *31 giro i. (P1)</i>	Cart. et plaque ass. *31 rot. g. (P1)	S24.45788	S24.45794	1

Item Pos. Ref. Pos. Pos.	Description <i>Descrizione</i>	Benennung <i>Descripcion</i>	Description	Part N° Teil Nr. Code N° Cod. N° Referencia T6CC	Part N° Teil Nr. Code N° Cod. N° Referencia T6CCM-T6CCP	Qty Stück Qtà Cant.
B	Cart. and plate ass'y *03 C.W. (P2) <i>Ins. cart. *03 oraria (P2)</i>	Pumpeneinheit *03 Rechtslauf (P2) <i>Conjunto cart. y platos *03 giro d. (P2)</i>	Cart. et plaque ass. *03 rot. d. (P2)	S24.10749	S24.40200	1
B	Cart. and plate ass'y *03 C.C.W. (P2) <i>Ins. cart. *03 antioraria (P2)</i>	Pumpeneinheit *03 Linkslauf (P2) <i>Conjunto cart. y platos *03 giro i. (P2)</i>	Cart. et plaque ass. *03 rot. g. (P2)	S24.10750	S24.40201	1
B	Cart. and plate ass'y *05 C.W. (P2) <i>Ins. cart. *05 oraria (P2)</i>	Pumpeneinheit *05 Rechtslauf (P2) <i>Conjunto cart. y platos *05 giro d. (P2)</i>	Cart. et plaque ass. *05 rot. d. (P2)	S24.10751	S24.40202	1
B	Cart. and plate ass'y *05 C.C.W. (P2) <i>Ins. cart. *05 antioraria (P2)</i>	Pumpeneinheit *05 Linkslauf (P2) <i>Conjunto cart. y platos *05 giro i. (P2)</i>	Cart. et plaque ass. *05 rot. g. (P2)	S24.10752	S24.40203	1
B	Cart. and plate ass'y *06 C.W. (P2) <i>Ins. cart. *06 oraria (P2)</i>	Pumpeneinheit *06 Rechtslauf (P2) <i>Conjunto cart. y platos *06 giro d. (P2)</i>	Cart. et plaque ass. *06 rot. d. (P2)	S24.10753	S24.40204	1
B	Cart. and plate ass'y *06 C.C.W. (P2) <i>Ins. cart. *06 antioraria (P2)</i>	Pumpeneinheit *06 Linkslauf (P2) <i>Conjunto cart. y platos *06 giro i. (P2)</i>	Cart. et plaque ass. *06 rot. g. (P2)	S24.10754	S24.40205	1
B	Cart. and plate ass'y *08 C.W. (P2) <i>Ins. cart. *08 oraria (P2)</i>	Pumpeneinheit *08 Rechtslauf (P2) <i>Conjunto cart. y platos *08 giro d. (P2)</i>	Cart. et plaque ass. *08 rot. d. (P2)	S24.10755	S24.40206	1
B	Cart. and plate ass'y *08 C.C.W. (P2) <i>Ins. cart. *08 antioraria (P2)</i>	Pumpeneinheit *08 Linkslauf (P2) <i>Conjunto cart. y platos *08 giro i. (P2)</i>	Cart. et plaque ass. *08 rot. g. (P2)	S24.10756	S24.40207	1
B	Cart. and plate ass'y *10 C.W. (P2) <i>Ins. cart. *10 oraria (P2)</i>	Pumpeneinheit *10 Rechtslauf (P2) <i>Conjunto cart. y platos *10 giro d. (P2)</i>	Cart. et plaque ass. *10 rot. d. (P2)	S24.10757	S24.40208	1
B	Cart. and plate ass'y *10 C.C.W. (P2) <i>Ins. cart. *10 antioraria (P2)</i>	Pumpeneinheit *10 Linkslauf (P2) <i>Conjunto cart. y platos *10 giro i. (P2)</i>	Cart. et plaque ass. *10 rot. g. (P2)	S24.10758	S24.40209	1
B	Cart. and plate ass'y *12 C.W. (P2) <i>Ins. cart. *12 oraria (P2)</i>	Pumpeneinheit *12 Rechtslauf (P2) <i>Conjunto cart. y platos *12 giro d. (P2)</i>	Cart. et plaque ass. *12 rot. d. (P2)	S24.26482	S24.40210	1
B	Cart. and plate ass'y *12 C.C.W. (P2) <i>Ins. cart. *12 antioraria (P2)</i>	Pumpeneinheit *12 Linkslauf (P2) <i>Conjunto cart. y platos *12 giro i. (P2)</i>	Cart. et plaque ass. *12 rot. g. (P2)	S24.26483	S24.40211	1
B	Cart. and plate ass'y *14 C.W. (P2) <i>Ins. cart. *14 oraria (P2)</i>	Pumpeneinheit *14 Rechtslauf (P2) <i>Conjunto cart. y platos *14 giro d. (P2)</i>	Cart. et plaque ass. *14 rot. d. (P2)	S24.10759	S24.40212	1
B	Cart. and plate ass'y *14 C.C.W. (P2) <i>Ins. cart. *14 antioraria (P2)</i>	Pumpeneinheit *14 Linkslauf (P2) <i>Conjunto cart. y platos *14 giro i. (P2)</i>	Cart. et plaque ass. *14 rot. g. (P2)	S24.10760	S24.40213	1
B	Cart. and plate ass'y *17 C.W. (P2) <i>Ins. cart. *17 oraria (P2)</i>	Pumpeneinheit *17 Rechtslauf (P2) <i>Conjunto cart. y platos *17 giro d. (P2)</i>	Cart. et plaque ass. *17 rot. d. (P2)	S24.10761	S24.40214	1
B	Cart. and plate ass'y *17 C.C.W. (P2) <i>Ins. cart. *17 antioraria (P2)</i>	Pumpeneinheit *17 Linkslauf (P2) <i>Conjunto cart. y platos *17 giro i. (P2)</i>	Cart. et plaque ass. *17 rot. g. (P2)	S24.10762	S24.40215	1
B	Cart. and plate ass'y *20 C.W. (P2) <i>Ins. cart. *20 oraria (P2)</i>	Pumpeneinheit *20 Rechtslauf (P2) <i>Conjunto cart. y platos *20 giro d. (P2)</i>	Cart. et plaque ass. *20 rot. d. (P2)	S24.31023	S24.40216	1
B	Cart. and plate ass'y *20 C.C.W. (P2) <i>Ins. cart. *20 antioraria (P2)</i>	Pumpeneinheit *20 Linkslauf (P2) <i>Conjunto cart. y platos *20 giro i. (P2)</i>	Cart. et plaque ass. *20 rot. g. (P2)	S24.40032	S24.40217	1
B	Cart. and plate ass'y *22 C.W. (P2) <i>Ins. cart. *22 oraria (P2)</i>	Pumpeneinheit *22 Rechtslauf (P2) <i>Conjunto cart. y platos *22 giro d. (P2)</i>	Cart. et plaque ass. *22 rot. d. (P2)	S24.10763	S24.40218	1
B	Cart. and plate ass'y *22 C.C.W. (P2) <i>Ins. cart. *22 antioraria (P2)</i>	Pumpeneinheit *22 Linkslauf (P2) <i>Conjunto cart. y platos *22 giro i. (P2)</i>	Cart. et plaque ass. *22 rot. g. (P2)	S24.10764	S24.40219	1
B	Cart. and plate ass'y *25 C.W. (P2) <i>Ins. cart. *25 oraria (P2)</i>	Pumpeneinheit *25 Rechtslauf (P2) <i>Conjunto cart. y platos *25 giro d. (P2)</i>	Cart. et plaque ass. *25 rot. d. (P2)	S24.10765	S24.40220	1

Item Pos. Ref. Pos. Pos.	Description <i>Descrizione</i>	Benennung <i>Descripcion</i>	Description	Part N° Teil Nr. Code N° Cod. N° Referencia T6CC	Part N° Teil Nr. Code N° Cod. N° Referencia T6CCM-T6CCP	Qty Stück Qté Q.tà Cant.
B	Cart. and plate ass'y *25 C.C.W. (P2) <i>Ins. cart. *25 antioraria (P2)</i>	Pumpeneinheit *25 Linkslauf (P2) <i>Conjunto cart. y platos *25 giro i. (P2)</i>	Cart. et plaque ass. *25 rot. g. (P2)	S24.10766	S24.40221	1
B	Cart. and plate ass'y *28 C.W.) (P2) <i>Ins. cart. *28 oraria (P2)</i>	Pumpeneinheit *28 Rechtslauf (P2) <i>Conjunto cart. y platos *28 giro d. (P2)</i>	Cart. et plaque ass. *28 rot. d. (P2)	S24.25547	S24.40222	1
B	Cart. and plate ass'y *28 C.C.W. (P2) <i>Ins. cart. *28 antioraria (P2)</i>	Pumpeneinheit *28 Linkslauf (P2) <i>Conjunto cart. y platos *28 giro i. (P2)</i>	Cart. et plaque ass. *28 rot. g. (P2)	S24.25546	S24.40223	1
B	Cart. and plate ass'y *31 C.W. (P2) <i>Ins. cart. *31 oraria (P2)</i>	Pumpeneinheit *31 Rechtslauf (P2) <i>Conjunto cart. y platos *31 giro d. (P2)</i>	Cart. et plaque ass. *31 rot. d. (P2)	S24.45771	S24.45775	1
B	Cart. and plate ass'y *31 C.C.W. (P2) <i>Ins. cart. *31 antioraria (P2)</i>	Pumpeneinheit *31 Linkslauf (P2) <i>Conjunto cart. y platos *31 giro i. (P2)</i>	Cart. et plaque ass. *31 rot. g. (P2)	S24.45772	S24.45776	1
C	Seal kit (S1 - 0,7 bar) (shafts 1-3-5) (T6CC - CCM) <i>Serie guarnizioni (S1 - 0,7 bar) (albero 1-3-5) (T6CC - CCM)</i>	Dichtringsatz (S1 - 0,7 bar) (Wellen 1-3-5) (T6CC - T6CCM) <i>Juego de juntas (S1 - 0,7 bar) (eje 1-3-5) (T6CC - T6CCM)</i>	Pochette de joint (S1 - 0,7 bar) (arbres 1-3-5) (T6CC - T6CCM)	S24.10352	S24.10352	1
	Seal kit (S1 - 0,7 bar) (T6CCP) <i>Serie guarnizioni (S1 - 0,7 bar) (T6CCP)</i>	Dichtringsatz (S1 - 0,7 bar) (T6CCP) <i>Juego de juntas (S1 - 0,7 bar) (T6CCP)</i>	Pochette de joint (S1 - 0,7 bar) (T6CCP)		S24.40230	1
	Seal kit (S4 - 7 bar) (shafts 1-3-5) <i>Serie guarnizioni (S4 - 7 bar) (albero 1-3-5)</i>	Dichtringsatz (S4 - 7 bar) (Wellen 1-3-5) <i>Juego de juntas (S4 - 7 bar) (eje 1-3-5)</i>	Pochette de joint (S4 - 7 bar) (arbres 1-3-5)	S24.10352.4	S24.10352.4	1
	Seal kit (S5 - 7 bar) (shafts 1-3-5) <i>Serie guarnizioni (S5 - 7 bar) (albero 1-3-5)</i>	Dichtringsatz (S5 - 7 bar) (Wellen 1-3-5) <i>Juego de juntas (S5 - 7 bar) (eje 1-3-5)</i>	Pochette de joint (S5 - 7 bar) (arbres 1-3-5)	S24.10352.5	S24.10352.5	1
D	Seal kit (S1 - 0,7 bar) (shafts 2-R-X-W-V-T) <i>Serie guarnizioni (S5 - 0,7 bar) (albero 2-R-X-W-V-T)</i>	Dichtringsatz (S1 - 0,7 bar) (Wellen 2-R-X-W-V-T) <i>Juego de juntas (S1 - 0,7 bar) (eje 2-R-X-W-V-T)</i>	Poch. de joint (S1 - 0,7 bar) (arbres 2-R-X-W-V-T)	S14.97724	S14.97724	1
	Seal kit (S4 - 0,7 bar) (shafts 2-R-X-W-V-T) <i>Serie guarnizioni (S4 - 0,7 bar) (albero 2-R-X-W-V-T)</i>	Dichtringsatz (S4 - 0,7 bar) (Wellen 2-R-X-W-V-T) <i>Juego de juntas (S4 - 0,7 bar) (eje 2-R-X-W-V-T)</i>	Poch. de joint (S4 - 0,7 bar) (arbres 2-R-X-W-V-T)	S14.97724.4	S14.97724.4	1
	Seal kit (S5 - 0,7 bar) (shafts 2-R-X-W-V-T) <i>Serie guarnizioni (S5 - 0,7 bar) (albero 2-R-X-W-V-T)</i>	Dichtringsatz (S5 - 0,7 bar) (Wellen 2-R-X-W-V-T) <i>Juego de juntas (S5 - 0,7 bar) (eje 2-R-X-W-V-T)</i>	Poch. de joint (S5 - 0,7 bar) (arbres 2-R-X-W-V-T)	S14.97724.5	S14.97724.5	1
E	Shaft and bearing ass'y (code 1) <i>Ins. albero (codice 1)</i>	Baugruppe (Welle u. Lager) (Typ 1) <i>Conjunto eje cojinete (codigo 1)</i>	Arbre et roulement ass. (code 1)	S24.10346	S24.10346	1
F	Shaft and bearing ass'y (code 2) <i>Ins. albero (codice 2)</i>	Baugruppe (Welle u. Lager) (Typ 2) <i>Conjunto eje cojinete (codigo 2)</i>	Arbre et roulement ass. (code 2)	S24.26208	S24.26208	1
G	Shaft and bearing ass'y (code 3) (T6CC - CCM) <i>Ins. albero (codice 3) (T6CC - T6CCM)</i>	Baugruppe (Welle u. Lager) (Typ 3) (T6CC - T6CCM) <i>Conjunto eje cojinete (codigo 3) (T6CC - T6CCM)</i>	Arbre et roulement ass. (code 3) (T6CC - T6CCM)	S24.10348	S24.10348	1
	Shaft and bearing ass'y (code 3) (T6CCP) <i>Ins. albero (codice 3) (T6CCP)</i>	Baugruppe (Welle u. Lager) (Typ 3) (T6CCP) <i>Conjunto eje cojinete (codigo 3) (T6CCP)</i>	Arbre et roulement ass. (code 3) (T6CCP)		S24.40231	1
H	Shaft and bearing ass'y (code 5) <i>Ins. albero (codice 5)</i>	Baugruppe (Welle u. Lager) (Typ 5) <i>Conjunto eje cojinete (codigo 5)</i>	Arbre et roulement ass. (code 5)	S24.10347	S24.10347	1
J	Shaft and bearing ass'y (code R) <i>Ins. albero (codice R)</i>	Baugruppe (Welle u. Lager) (Typ R) <i>Conjunto eje cojinete (codigo R)</i>	Arbre et roulement ass. (code R)		S24.30001	1
K	Shaft and bearing ass'y (code X) <i>Ins. albero (codice X)</i>	Baugruppe (Welle u. Lager) (Typ X) <i>Conjunto eje cojinete (codigo X)</i>	Arbre et roulement ass. (code X)		S24.26211	1
L	Shaft and bearing ass'y (code W) <i>Ins. albero (codice W)</i>	Baugruppe (Welle u. Lager) (Typ W) <i>Conjunto eje cojinete (codigo W)</i>	Arbre et roulement ass. (code W)		S24.26376	1
M	Shaft and bearing ass'y (code V) <i>Ins. albero (codice V)</i>	Baugruppe (Welle u. Lager) (Typ V) <i>Conjunto eje cojinete (codigo V)</i>	Arbre et roulement ass. (code V)		S14.97723	1
N	Shaft and bearing ass'y (code T) <i>Ins. albero (codice T)</i>	Baugruppe (Welle u. Lager) (Typ T) <i>Conjunto eje cojinete (codigo T)</i>	Arbre et roulement ass. (code T)		S24.40034	1

Item Pos. Ref. Pos. Pos.	Description <i>Descrizione</i>	Benennung <i>Descripcion</i>	Description	Part N° Teil Nr. Code N° Cod. N° Referencia T6CC	Part N° Teil Nr. Code N° Cod. N° Referencia T6CCM-T6CCP	Qty Stück Qté Q.tà Cant.
P	Shaft and bearing ass'y (code 4) (T6CCP) <i>Ins. albero (codice 4) (T6CCP)</i>	Baugruppe (Welle u. Lager) (Typ 4) (T6CCP) <i>Conjunto eje cojinete (codigo 4) (T6CCP)</i>	Arbre et roulement ass. (code 4) (T6CCP)		S24.58341	1
Q	Shaft and bearing ass'y (code 6) (T6CCP) <i>Ins. albero (codice 6) (T6CCP)</i>	Baugruppe (Welle u. Lager) (Typ 6) (T6CCP) <i>Conjunto eje cojinete (codigo 6) (T6CCP)</i>	Arbre et roulement ass. (code 6) (T6CCP)		S24.40232	1
R	Port plate-rear and bush ass'y C.C.W. (P2) <i>Ins. piatto distributore post. antioraria (P2)</i>	Steuerplatte mit Buchse Linkslauf (P2) <i>Coj. plato dist. trase. con coj. fricción giro I (P2)</i>	Plaque ar. et bague ass. rot. gauche (P2)	S24.10808		1
S	Port plate-rear and bush ass'y C.W. (P2) <i>Ins. piatto distributore post. oraria (P2)</i>	Steuerplatte mit Buchse Rechtslauf (P2) <i>Coj. plato dist. trase. con coj. fricción giro D (P2)</i>	Plaque ar. et bague ass. rot. droite (P2)	S24.10807		1
T	Port plate-rear and bush ass'y (P2) <i>Ins. piatto distributore post. (P2)</i>	Steuerplatte mit Buchse (P2) <i>Coj. plato dist. trase. con coj. fricción (P2)</i>	Plaque ar. et bague ass. (P2)		S24.10349	1
U	Port plate-rear ass'y C.C.W. (P1) <i>Ins. piatto distributore post. antioraria (P1)</i>	Steuerplatte Linkslauf (P1) <i>Coj. plato dist. trasero giro I (P1)</i>	Plaque ar. ass. rot. gauche (P1)	S24.10806		1
V	Port plate-rear ass'y C.W. (P1) <i>Ins. piatto distributore post. oraria (P1)</i>	Steuerplatte Rechtslauf (P1) <i>Coj. plato dist. trasero giro D (P1)</i>	Plaque ar. ass. rot. droite (P1)	S24.10805		1
W	Port plate-rear ass'y (P1) <i>Ins. piatto distributore post. (P1)</i>	Steuerplatte (P1) <i>Coj. plato dist. trasero (P1)</i>	Plaque ar. ass. (P1)		S24.10418	1
Notes						

Model Code

Model number :

Series _____

Sever duty shaft _____

One letter can be added to specify special parts in series _____

Cam ring for P1 & P2 _____

(Volumetric displacement) (ml/rev.)

003 = 10,8
005 = 17,2
006 = 21,3
008 = 26,4
010 = 34,1

Type of shaft _____

1 = keyed (non SAE)
3 = splined (SAE BB)
5 = splined (SAE B)

Sever duty shaft (T6CCW only)

2 = keyed (SAE BB)

Direction of rotation _____

R = Clockwise
L = Counter-clockwise

Porting combination _____

00 = standard

Design letter _____

Seal class _____

1 = S1 - BUNA N
4 = S4 - EPDM
5 = S5 - VITON

Mounting w/connection variables _____

4 bolts SAE flange (J518c)

	P1 = 1"		S = 3"	
	UNC		Metric	
P2	1"	3/4"	1"	3/4"
Code	00	01	0M	WO

	P1 = 1"		S = 2"1/2	
	UNC		Metric	
P2	1"	3/4"	1"	3/4"
Code	10	11	1M	W1

Modifications _____

Typenschlüssel

Typenbezeichnung :

Baureihe _____

Hochleistungswelle _____

Optionen _____

Hubring P1 & P2 _____

(Geometrisches Fördervolumen) (cm³/U)

012 = 37,1
014 = 46,0
017 = 58,3
020 = 63,8

Art der Welle _____

1 = Paßfederwelle (nicht SAE)
3 = Vielkeilwelle (SAE BB)
5 = Vielkeilwelle (SAE B)

Hochleistungswelle (nur für T6CCW)

2 = Paßfederwelle (SAE BB)

Drehrichtung _____

R = Rechtslauf
L = Linkslauf

Lage der Anschlüsse _____

00 = standard

Ausführungsbuchstabe _____

Dichtungsklasse _____

1 = S1 - BUNA N
4 = S4 - EPDM
5 = S5 - VITON

Gehäuse-Anschlußgröße _____

SAE Flansch (J518c)

	P1 = 1"		S = 3"	
	UNC		Metrisch	
P2	1"	3/4"	1"	3/4"
Typ	00	01	0M	WO

	P1 = 1"		S = 2"1/2	
	UNC		Metrisch	
P2	1"	3/4"	1"	3/4"
Typ	10	11	1M	W1

Modifikationen _____

Designation - type

Numéro du modèle :

Série _____

Arbre renforcé _____

Une lettre peut être ajoutée pour spécifier les pièces spéciales dans la série.

Came pour P1 & P2 _____

(Cylindrée théorique) (cm³/tr)

022 = 70,3
025 = 79,3
028 = 88,8
031 = 100,0

Type d'arbre _____

1 = à clavette (non SAE)
3 = à cannelures (SAE BB)
5 = à cannelures (SAE B)

Arbre renforcé (T6CCW seulement)

2 = à clavette (SAE BB)

Sens de rotation _____

R = à droite
L = à gauche

Combinaison des orifices _____

00 = standard

Conception _____

Classe de joint _____

1 = S1 - BUNA N
4 = S4 - EPDM
5 = S5 - VITON

Option sur orifices _____

Bride SAE 4 trous (J518c)

	P1 = 1"		S = 3"	
	UNC		Métrique	
P2	1"	3/4"	1"	3/4"
Code	00	01	0M	WO

	P1 = 1"		S = 2"1/2	
	UNC		Métrique	
P2	1"	3/4"	1"	3/4"
Code	10	11	1M	W1

Modifications _____

T6CC W . - 010 - 022 - 1 R 00 - C 1 - 00 - ..

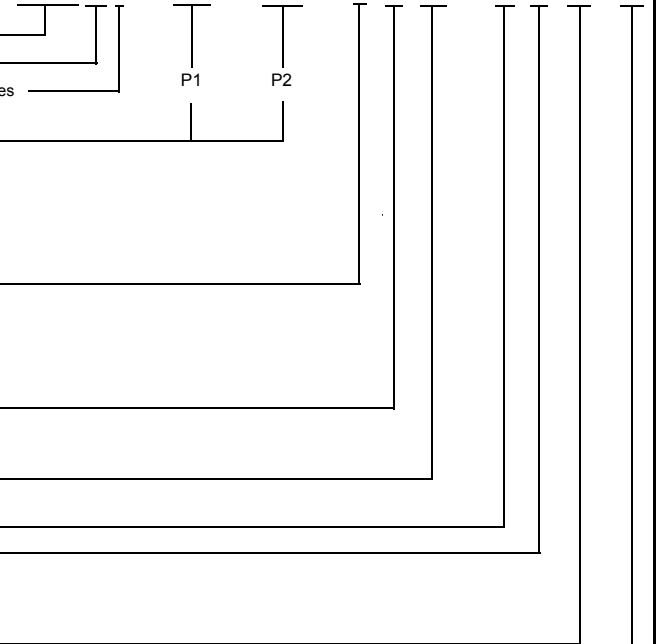

Designazione

Clave de designación

Sigla :

Referencia modelo :

T6CC W. - 010 - 022 - 1 R 00 - C 1 - 00 - ..

Serie _____

Serie _____

Albero per impiego gravoso _____

Eje trabajo duro _____

Una lettera può essere aggiunta per specificare parti speciali nella serie _____

Una letra puede ser añadida para especificar piezas especiales en la serie _____

Tipo di cartuccia P1 & P2 _____

Aro volumetrico para P1 & P2 _____

(Cilindrata) (ml/giro)

(Cilindrada) (ml/rev)

003 = 10,8

017 = 58,3

005 = 17,2

020 = 63,8

006 = 21,3

022 = 70,3

008 = 26,4

025 = 79,3

010 = 34,1

028 = 88,8

012 = 37,1

031 = 100,0

014 = 46,0

Tipo di albero _____

Tipo de eje _____

1 = a chiavetta

1 = chaveteado (no SAE)

3 = scanalato (SAE BB)

3 = estriado (SAE BB)

5 = scanalato (SAE B)

5 = estriado (SAE B)

Albero per impiego gravoso (solo per T6CCW)

Eje trabajo duro (solo T6CCW)

2 = a chiavetta (SAE BB)

2 = chaveteado (SAE BB)

Senso di rotazione _____

Sentido de giro _____

R =orario

R = Derecha

L = Antiorario

L = Izquierda

Orientamento delle bocche _____

Posición de bocas _____

00 = standard

00 = estándar

Disegno _____

Letra de diseño _____

Tipo di guarnizioni _____

Clase de juntas _____

1 = S1 - BUNA N

1 = S1 - BUNA N

4 = S4 - EPDM

4 = S4 - EPDM

5 = S5 - VITON

5 = S5 - VITON

Dimensioni delle bocche _____

Conexiones de montaje _____

Flange SAE 4 fori (J518c)

	P1 = 1"		S = 3"	
	UNC		Metrica	
P2	1"	3/4"	1"	3/4"
Codice	00	01	0M	WO

	P1 = 1"		S = 3"	
	UNC		Metrico	
P2	1"	3/4"	1"	3/4"
Codigo	00	01	0M	WO

	P1 = 1"		S = 2"1/2	
	UNC		Metrica	
P2	1"	3/4"	1"	3/4"
Codice	10	11	1M	W1

	P1 = 1"		S = 2"1/2	
	UNC		Metrico	
P2	1"	3/4"	1"	3/4"
Codigo	10	11	1M	W1

Modifiche _____

Modificaciones _____

Model Code

Model number :

Series M = Mobile 1 shaft seal _____
Series P = Mobile 2 shaft seal _____

Sever duty shaft _____

One letter can be added to specify special parts in series _____

Cam ring for P1 & P2 _____

(Volumetric displacement) (ml/rev.)

B03 = 10,8

B05 = 17,2

B06 = 21,3

B08 = 26,4

B10 = 34,1

Type of shaft _____

M version

1 = keyed (non SAE)

3 = splined (SAE BB)

5 = splined (SAE B)

P version

3 = splined (no SAE)

4 = splined (SAE BB)

6 = splined (no SAE)

Sever duty shaft (T6CCMW only)

2 = keyed (SAE BB)

R = keyed special

X = keyed special

W = keyed special

V = keyed special

T = splined (SAE J718c)

Direction of rotation _____

R = Clockwise

L = Counter-clockwise

Porting combination _____

00 = standard

Design letter _____

Seal class _____

1 = S1 - BUNA N

4 = S4 - EPDM

5 = S5 - VITON

Mounting w/connection variables _____

4 bolts SAE flange (J518c)

	P1 = 1"		S = 3"	
	UNC	Metric	UNC	Metric
P2	1"	3/4"	1"	3/4"
Code	00	01	0M	WO

	P1 = 1"		S = 2"1/2	
	UNC	Metric	UNC	Metric
P2	1"	3/4"	1"	3/4"
Code	10	11	1M	W1

Modifications _____

Typenschlüssel

Typenbezeichnung :

Serie M = Mobil, 1 Wellendichtung _____

Serie P = Mobil, 2 Wellendichtungen _____

Hochleistungswelle _____

Optionen _____

Hubring P1 & P2 _____

(Geometrisches Fördervolumen) (cm³/U)

B12 = 37,1

B14 = 46,0

B17 = 58,3

B20 = 63,8

Art der Welle _____

Version M

1 = Paßfederwelle (nicht SAE)

3 = Vielkeilwelle (SAE BB)

5 = Vielkeilwelle (SAE B)

Version P

3 = Vielkeilwelle (nicht SAE)

4 = Vielkeilwelle (SAE BB)

6 = Vielkeilwelle (nicht SAE)

Hochleistungswelle (nur für T6CCMW)

2 = Paßfederwelle (SAE BB)

R = Spezialpaßfederwelle

X = Spezialpaßfederwelle

W = Spezialpaßfederwelle

V = Spezialpaßfederwelle

T = Vielkeilwelle (SAE J518c)

Drehrichtung _____

R = Rechtslauf

L = Linkslauf

Lage der Anschlüsse _____

00 = standard

Ausführungsbuchstabe _____

Dichtungs-klasse _____

1 = S1 - BUNA N

4 = S4 - EPDM

5 = S5 - VITON

Gehäuse-Anschlußgröße _____

SAE Flansch (J518c)

	P1 = 1"		S = 3"	
	UNC	Metrisch	UNC	Metrisch
P2	1"	3/4"	1"	3/4"
Typ	00	01	0M	WO

	P1 = 1"		S = 2"1/2	
	UNC	Metrisch	UNC	Metrisch
P2	1"	3/4"	1"	3/4"
Typ	10	11	1M	W1

Modifikationen _____

Designation - type

Numéro du modèle :

Série M = Mobile 1 joint d'arbre _____

Série P = Mobile 2 joints d'arbre _____

Arbre renforcé _____

Une lettre peut être ajoutée pour spécifier les pièces spéciales dans la série. _____

Came pour P1 & P2 _____

(Cylindrée théorique) (cm³/tr)

B22 = 70,3

B25 = 79,3

B28 = 88,8

B31 = 100,0

Type d'arbre _____

Version M

1 = à clavette (non SAE)

3 = à cannelures (SAE BB)

5 = à cannelures (SAE B)

Version P

3 = à cannelures (non SAE)

4 = à cannelures (SAE BB)

6 = à cannelures (non SAE)

Arbre renforcé (T6CCMW seulement)

2 = à clavette (SAE BB)

R = à clavette spécial

X = à clavette special

W = à clavette special

V = à clavette special

T = à cannelures (SAE J718c)

Sens de rotation _____

R = à droite

L = à gauche

Combinaison des orifices _____

00 = standard

Conception _____

Classe de joint _____

1 = S1 - BUNA N

4 = S4 - EPDM

5 = S5 - VITON

Option sur orifices _____

Bride SAE 4 trous (J518c)

	P1 = 1"		S = 3"	
	UNC	Métrique	UNC	Métrique
P2	1"	3/4"	1"	3/4"
Code	00	01	0M	WO

	P1 = 1"		S = 2"1/2	
	UNC	Métrique	UNC	Métrique
P2	1"	3/4"	1"	3/4"
Code	10	11	1M	W1

Modifications _____

T6CC* W . - B10 - B22 - 3 R 00 - D 1 - 00 - ..

P1

P2

Designazione

Clave de designación

Sigla :

Referencia modelo :

T6CC* W . - B10 - B22 - 3 R 00 - D 1 - 00 - ..

Serie M = Mobile 1 guarnizione albero
Serie P = Mobile 2 guarnizioni albero

Serie M = Movil 1 reten eje
Serie P = movil 2 retenes eje

Albero per impiego gravoso

Eje trabajo duro

Una lettera può essere aggiunta per specificare parti speciali nella serie

Una letra puede ser añadide pasa especificar piezas especiales en la serie

Tipo di cartuccia P1 & P2
 (Cilindrata) (ml/giro)
 B03 = 10,8
 B05 = 17,2
 B06 = 21,3
 B08 = 26,4
 B10 = 34,1
 B12 = 37,1
 B14 = 46,0

Aro volumetrico para P1 & P2
 (Cilindrada) (ml/rev)
 B17 = 58,3
 B20 = 63,8
 B22 = 70,3
 B25 = 79,3
 B28 = 88,8
 B31 = 100,0

Tipo di albero

Tipo de eje

Version M
 1 = a chiavetta
 3 = scanalato (SAE BB)
 5 = scanalato (SAE B)

Version M
 1 = chaveteado (no SAE)
 3 = estriado (SAE BB)
 5 = estriado (SAE B)

Version P
 3 = a chiavetta
 4 = a chiavetta (SAE BB)
 6 = a chiavetta

Version P
 3 = estriado (no SAE)
 4 = estriado (SAE BB)
 6 = estriado (no SAE)

Albero per impiego gravoso (solo per T6CCMW)
 2 = a chiavetta (SAE BB)
 R = a chiavetta
 X = a chiavetta
 W = a chiavetta
 V = a chiavetta
 T = scanalato (SAE J718c)

Eje trabajo duro (solo T6CCMW)
 2 = chaveteado (SAE BB)
 R = chaveteado especial
 X = chaveteado especial
 W = chaveteado especial
 V = chaveteado especial
 T = estriado (SAE J718c)

Senso di rotazione
 R =orario
 L = Antiorario

Sentido de giro
 R = Derecha
 L = Izquierda

Orientamento delle bocche
 00 = standard

Posición de bocas
 00 = estándar

Disegno

Letra de diseño

Tipo di guarnizioni
 1 = S1 - BUNA N
 4 = S4 - EPDM
 5 = S5 - VITON

Clase de juntas
 1 = S1 - BUNA N
 4 = S4 - EPDM
 5 = S5 - VITON

Dimensioni delle bocche

Conexiones de montaje

Flange SAE 4 fori (J518c)

	P1 = 1"		S = 3"	
	UNC	Metrica	UNC	Metrica
P2	1"	3/4"	1"	3/4"
Codice	00	01	0M	WO

	P1 = 1"		S = 3"	
	UNC	Metrica	UNC	Metrica
P2	1"	3/4"	1"	3/4"
Codigo	00	01	0M	WO

	P1 = 1"		S = 2"1/2	
	UNC	Metrica	UNC	Metrica
P2	1"	3/4"	1"	3/4"
Codice	10	11	1M	W1

	P1 = 1"		S = 2"1/2	
	UNC	Metrica	UNC	Metrica
P2	1"	3/4"	1"	3/4"
Codigo	10	11	1M	W1

Modifiche

Modificaciones