



Truck Hydraulics

*Fixed and Variable Displacement
Pumps, Motors and Accessories*

*Catalogue HY17-8200/UK
March 2004*



F1

F2

T1

VP1

PTO info

Accessories

Conversion factors

1 kg	2.20 lb
1 N	0.225 lbf
1 Nm	0.738 lbf ft
1 bar	14.5 psi
1 l	0.264 US gallon
1 cm ³	0.061 cu in
1 mm	0.039 in
$\frac{9}{5} \text{ }^{\circ}\text{C} + 32$	1 $^{\circ}\text{F}$

General Information

F1 Pump ISO

Series F1 is a further development of our well known 'truck pump', the F1. The F1 offers many additional values for operators of cargo cranes, hook loaders, skip loaders, forest cranes, concrete mixers and similar truck applications.

Series F1 is a very efficient and straight forward pump design with unsurpassed reliability. Its small envelope size gives a simple and inexpensive installation.



New features of the F1 are:

- Higher selfpriming speeds
- Operating pressures to 400 bar
- New frame sizes to meet market requirements
- Higher overall efficiency
- Increased reliability
- Reduced noise level
- Possible leakage paths reduced
- Easier to change direction of rotation
- Smaller installation dimensions

... thanks to:

- 45° bent-axis angle
- Optimal inlet port geometry
- New ball and roller bearings
- Single housing design
- Optimized commutation - low flow pulsations

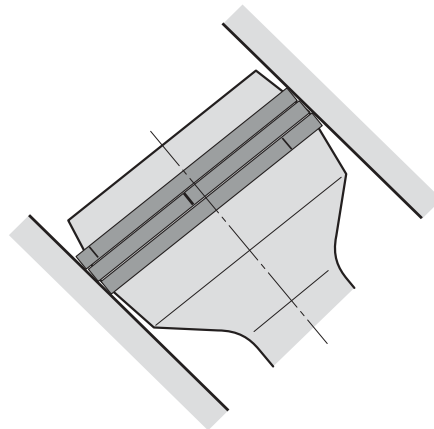

F1 piston with laminated piston ring.

All of this in addition to previous F1 features:

- Spherical pistons - high speeds
- Laminated piston rings - low leakage
- Positive synchronization with timing gear
- Installation above the reservoir level possible
- Tolerates low temperatures and high temperature shocks
- Shaft end and mounting flange meet the ISO standard for all sizes

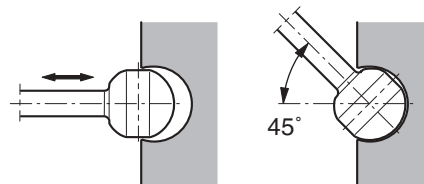

F1 piston-to-shaft locking.

F1 Pump SAE

All of this in addition to previous F1 features:

- Spherical pistons - high speeds
- Laminated piston rings - low leakage
- Positive synchronization with timing gear
- Operating pressure 350 bar
- Installation above the reservoir level possible
- Tolerates low temperatures and high temperature shocks
- Shaft end and mounting flange meet the standard SAE-B for sizes 25 to 61



1

F1 Motor ISO

All of this in addition to previous F1 features:

- Spherical pistons - high speeds
- Laminated piston rings - low leakage
- Positive synchronization with timing gear
- Operating pressure 250 bar
- Installation above the reservoir level possible
- Tolerates low temperatures and high temperature shocks
- Shaft end and mounting flange meet the ISO standard for all sizes



F2 Twin-flow pump

Series F2 is a further development of the twin-flow version of series F1, the very first bent-axis truck pump on the market to feature two entirely independent flows.

With a suitable build-up of the hydraulic system, the main advantage with a twin-flow pump is that three different flows can be provided at the same engine speed.

The twin-flow pump makes it possible to further optimize the hydraulic system and offers:

- Less energy consumption
- Reduced risk of system overheating
- Lower weight
- Easier installation
- Standardized system solutions

The twin-flow pump makes it possible to operate two work functions that are independent of each other which leads to higher speed and an increased operating precision.

Another requirement can be a large and a small flow, or two equal flows. All of these alternatives are possible with the twin-flow pump.

The pump can be utilized to provide one flow at high system pressure, and, as soon as the pressure has decreased sufficiently, add the flow from the other circuit.

This eliminates the risk of exceeding the PTO power rating and, at the same time, provide an optimal driving function.



Typical twin-flow applications

- Large truck loaders
- Forestry cranes
- Hook loaders/lift dumpers
- Tipper/crane combinations
- Refuse collecting vehicles

The pump shaft end/mounting flange meets the ISO standard and suits PTO direct mounting. Suitable PTO:s for most European truck gearboxes are available from our sales offices and distributors.

T1 Pump

The T1 fixed displacement pump is a further development of series T1, which was specifically designed to meet the requirements of light duty truck applications with short, non-frequent operating cycles such as tippers, and small loaders.

The design is very similar to that of the F1 series pumps but is even more compact. It utilizes our well proven 40° and 45° concepts with spherical pistons and laminated piston rings, offering high volumetric and mechanical efficiencies and, thanks also to the small number of parts, unprecedented reliability.

- Input power to 71 kW
- Shaft speed to 2300 rpm
- Operating pressure to 350 bar
- High overall efficiency
- Low weight
- Small installed envelope
- Proven reliability
- Easy servicing

The T1, with shaft and mounting flange configuration conforming to the European standard, can be installed on most European truck gearboxes. Suitable power-take-offs are also available from Parker Hannifin.

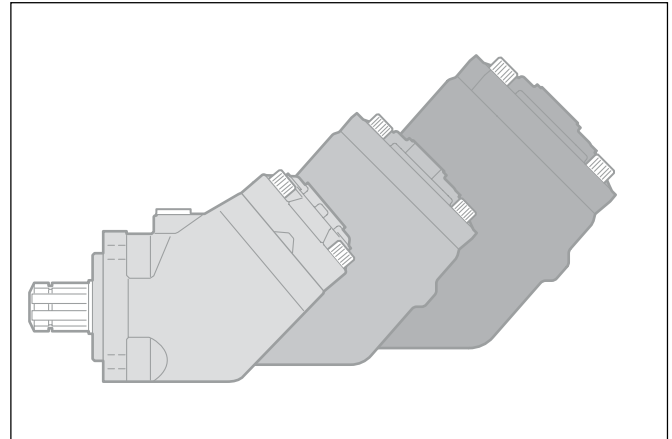

Typical T1 applications

- Front end tippers
- Under boddy tippers
- Light and low frequent used “ hydraulic circuit “

VP1 Pump

The VP1 is the world's first variable displacement pump for truck applications. It can be close-coupled to a gearbox PTO (power take-off) or to a coupling independent PTO (e.g. an engine PTO) which meets ISO standard 7653-1985.

An application that makes full use of all the features of the VP1 is truck cranes with a load sensing system. The complex systems of refuse collection vehicles and sewage trucks as well as various combinations of tippers, cranes, snow ploughs, and salt/sand spreaders can also be greatly simplified and optimized with the VP1 pump.

The VP1 provides the hydraulic system with the correct amount of fluid at precisely the right moment, effectively reducing energy consumption and heat generation. This means a smoother and quieter running system with much reduced impact on the environment. The VP1 is highly efficient, has a small installation envelop and is extremely light. It is reliable, economical and easy to install.

Design

Large angle - compact design

The pump design permits a large angle, 20°, between piston and slipper shoe/swashplate, providing compactness and small outer dimensions.

Tandem coupling

The through-shaft permits tandem coupling of an additional pump, such as a series F1 fixed displacement pump.

Accepts high external shaft loads

Heavy duty roller bearings allow radial loads on the VP1 shaft end which makes it possible to install a gear directly on the shaft without additional bearings.

Long life

The VP1 is designed for trucks with hydraulic load sensing systems. It is sturdy, yet simple, with few moving parts. The result is a reliable pump with long service life.



The two frame sizes, VP1-45 and -75, have the same, small installation dimensions. Shaft and mounting flange follow the European ISO standard 7653-1985. The VP1 is suitable for all load sensing systems, regardless of make.

Features

- Variable displacement
- Low noise level
- High power-to-weight ratio
- Compact and light
- Highly efficient
- Sturdy design
- Withstands low temperatures
- Reliable and easy to service
- Can be close coupled and tandem mounted.

High overall efficiency

Uniquely designed parts like the piston/slipper shoe and 'floating' valve plate minimize mechanical losses. The valve plate, which floats on five pistons, contributes to a quiet running pump with low internal leakage and high volumetric efficiency.

Retainer plate

The retainer plate (refer to the cut-away illustration on page 31) is of a heavy duty design which makes the pump withstand high shaft speeds and fast speed changes.

Accessories

Adaptor kits and accessories for F1, F2, T1 and VP1 pumps

BLA

Boost unit.

Fittings

Suction fittings and fitting kits

Bypass valve

BPV-F1/-T1, BPV-F1-25 and 81, BPV-F2, BPV-VP1, BPV-L.

Unloading valve

ES line mounted unloading valve.

Torque limiting valve

MB-F2-H1

Electrical connector

Electrical connector assembly

Accessories

Universal PTO air valve kits, PTO adapter kits for engines, cardan shafts, pump couplings and mounting brackets, return filter and filter indicator, air breather filter and splitter boxes (SB 1-1,18, 1-1,54)

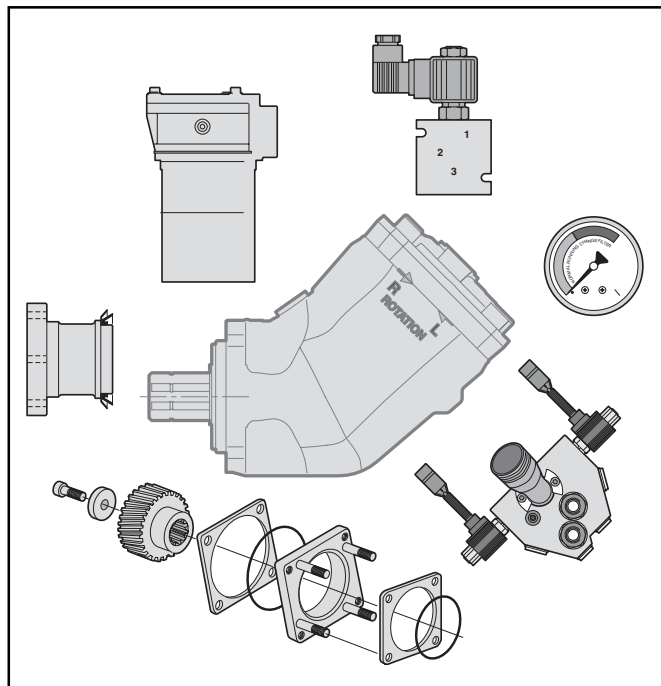

Pump selection

F1 and T1

The following table shows pump flow at selected PTO gear ratios and engine rpm's.

PTO gear ratio	Engine speed [rpm]	Pump flow [l/min]						
		F1-25	F1-41	T1-51 F1-51	F1-61	T1-81 F1-81	F1-101	T1 121
1:0.8	800	16	26	33	38	52	66	76
	900	18	29	37	43	59	74	85
	1000	20	33	41	48	65	82	95
	1100	23	36	45	52	72	91	104
	1200	25	39	49	57	78	99	114
1:1.0	800	20	33	41	48	65	82	95
	900	23	37	46	54	73	93	107
	1000	26	41	51	60	82	103	119
	1100	28	45	56	65	90	113	130
	1200	31	49	61	71	98	123	142
1.1.25	800	26	41	51	60	82	103	119
	900	29	46	57	67	92	116	133
	1000	32	51	64	74	102	129	148
	1100	35	56	70	82	111	141	163
	1200	38	61	77	89	122	154	178
1:1.5	800	31	49	61	71	98	123	142
	900	35	55	69	80	110	139	160
	1000	38	61	77	90	122	154	178
	1100	42	67	84	98	135	170	196
	1200	46	74	92	107	147	185	213

NOTE:

- Make sure max torque and bending moment (due to the weight of the pump) of the utilized PTO are not exceeded. (The approx. center of gravity of the various pump sizes are shown in the installation drawings).
- Make sure max allowed output torque from the PTO is not exceeded.
- Contact Parker Hannifin if the inlet (suction) pressure is believed to be less than 1.0 bar (absolute); insufficient inlet pressure can cause noise and pump damage because of cavitation.

Flow and torque formulas (no regard to efficiency)

$$\text{Flow: } Q = \frac{D \times n}{1000} \text{ [l/min]}$$

where: D is pump displacement [cm³/rev]
n is shaft speed [rpm]

$$\text{Torque: } M = \frac{D \times p}{63} \text{ [Nm]}$$

where: D is pump displacement [cm³/rev]
p is utilized pressure [bar]

A suitable pump size for a truck application can be selected as follows:

Operating conditions

As an example, a cargo crane specifies:

- Flow: 60-80 l/min
- Pressure: 230 bar
- Diesel engine speed \approx 800 rpm

Determine pump speed

A Volvo type BKUH 1123 PTO on gearbox SR 1700, for example, has a gear ratio of 1:1.54.

The pump speed will be:

- $800 \times 1.54 \approx 1200$ rpm

Select a suitable pump size

Use diagram 1 and select a pump that will provide 60 - 80 l/min at 1200 rpm.

Follow line 'a' (1200 rpm) until it crosses line 'b' (70 l/min).

- F1-61 is a suitable choice

Required input torque

Make sure the PTO and the gear-box tolerates the pump torque. Use diagram 2 to obtain the required pump torque.

Follow a line from 'c' (230 bar) until it crosses the F1-60 line (the selected pump).

- Read 220 Nm (at 'd')

NOTE: A rule-of-thumb is to select the highest PTO ratio and the smallest pump size that meets the crane specification without exceeding the pump speed, pressure, and power limitations.

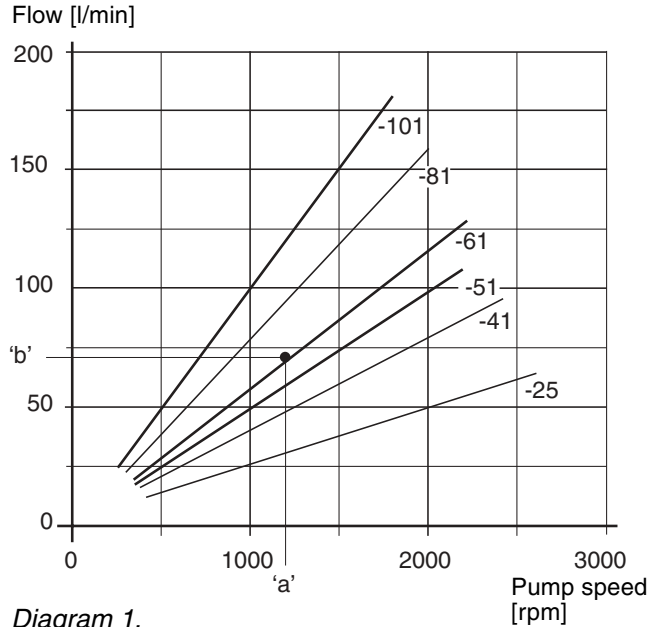

Diagram 1.

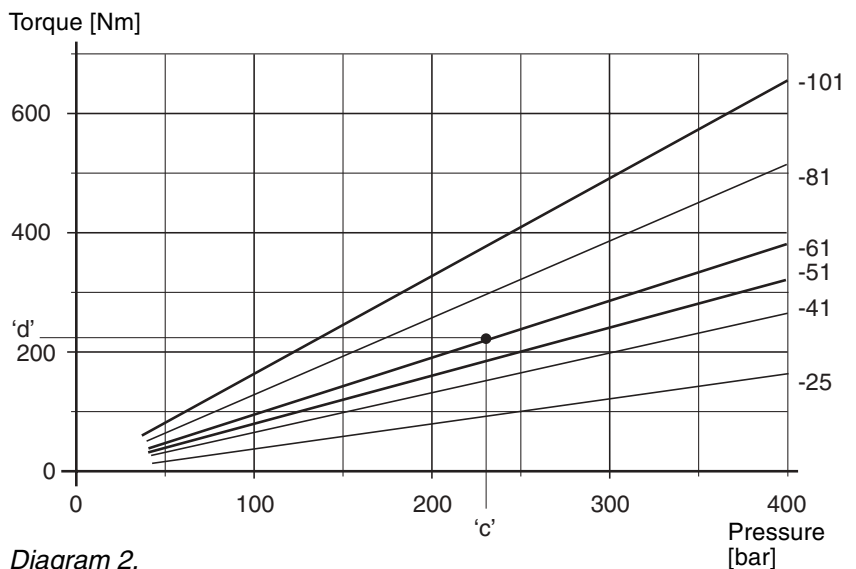

Diagram 2.

Line selection
all pumps

Line type Flow velocity [m/s]

Inlet (suction)	max 1.0
Outlet (pressure)	max 5.0

Flow rate [l/min]	Flow velocity [m/s] at selected line sizes [mm/inches]					
	19 / 3/4"	25 / 1"	32 / 1 1/4"	38 / 1 1/2"	51 / 2"	64 / 2 1/2"
25	1.5	0.8	0.5	0.4	0.2	0.1
50	2.9	1.7	1.0	0.7	0.4	0.3
75	4.4	2.5	1.6	1.1	0.6	0.4
100	(5.9)	3.4	2.1	1.5	0.8	0.5
150	(8.8)	(5.1)	3.1	2.2	1.3	(0.8)
200	-	-	4.1	2.9	1.6	1.0

Inlet (suction) line

Table 1.

Outlet (pressure) line



In order to obtain sufficient inlet (suction) pressure to the pump, low noise level and low heat generation, flow speeds shown in table 2, right, should not be exceeded.

From table 1 (page 12), select the smallest line dimension that meets the flow speed recommendation; example:

- At 100 l/min, a 50 mm suction line and a 25 mm pressure line is needed.

NOTE: Long inlet (suction) lines, low inlet pressure (caused by e.g. a reservoir positioned below the pump) and/or low temperatures may require larger line dimensions.

Alternatively, the pump speed will have to be lowered to avoid pump cavitation (which may cause noise, deteriorating performance and pump damage).

Line type	Flow velocity [m/s]
Inlet (suction)	max 1.0
Outlet (pressure)	max 5.0

Nomogram

Flow - Line dimension - Flow velocity

Table 2.

Example 1
 Pressure line
 Q = 65 l/min
 d = 3/4"
 v = 3.8 m/s

Example 2
 Suction line
 Q = 50 l/min
 v = 0.8
 d = 1 1/2"

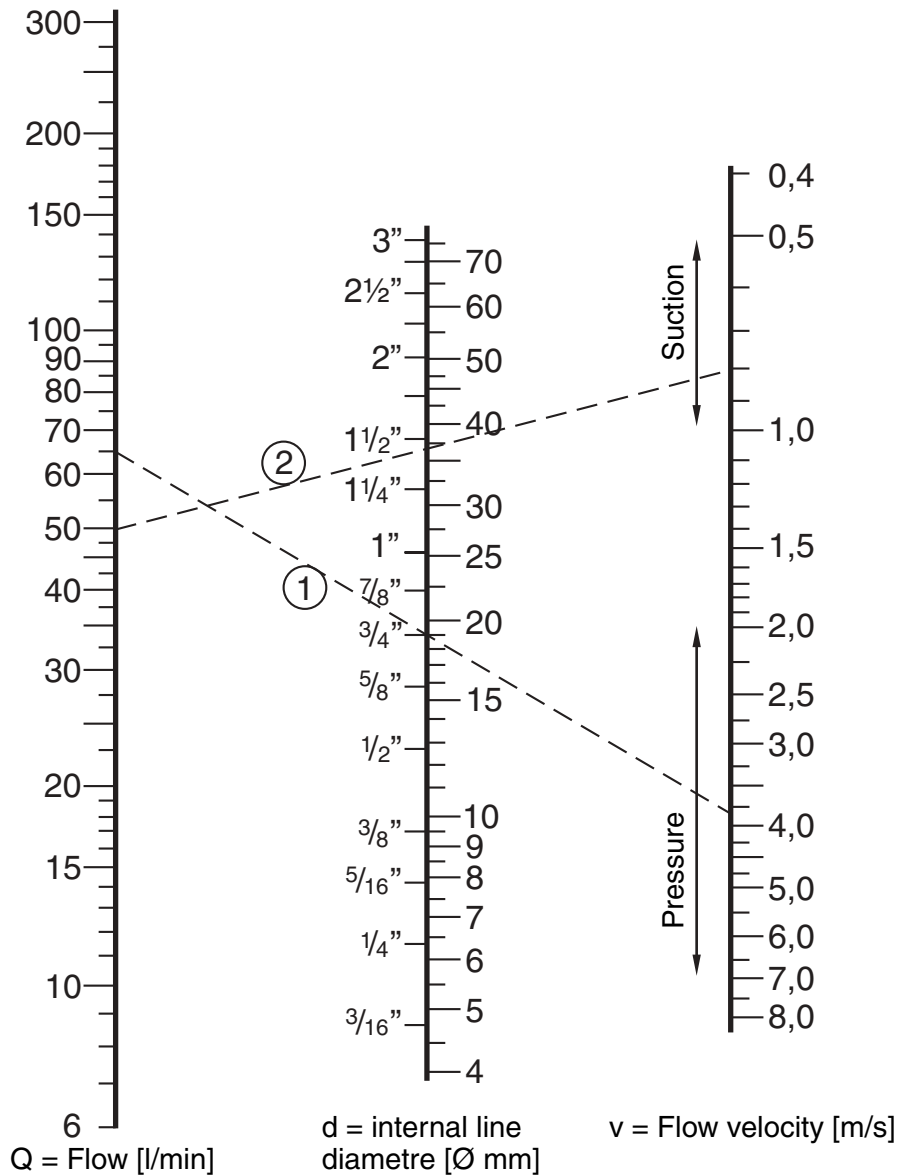

T1 Pump

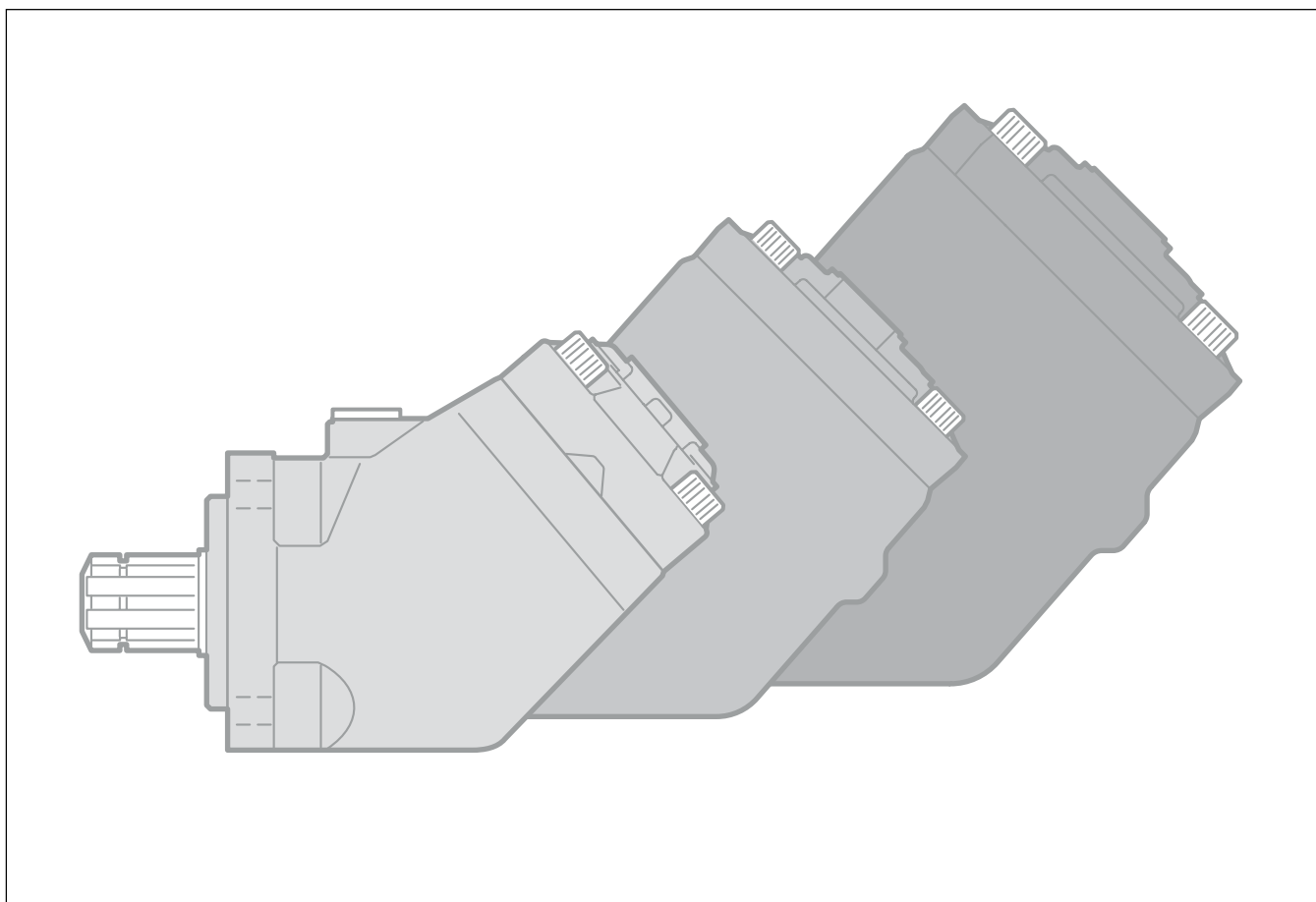

Content

[Pump and line selection](#)

[Specifications](#)

[Installation dimensions](#)

[Ordering code](#)

[Port size](#)

[Standard versions](#)

[Suction fittings](#)

[Installation and start-up](#)

Specifications

T1 frame size	51	81	121	
Displacement [cm ³ /rev]	50.0	81.5	118,5	
Max flow ¹⁾ [l/min]	80	163 ³⁾	213 ³⁾	
Max operating pressure [bar]	continuous	200	200	
	intermittent ⁴⁾	350	350	
Shaft speed [rpm]				
short circuited pump (low press.)	2300	2300	2300	
max speed ²⁾	2100	2000 ³⁾	1600 ³⁾	
Torque ¹⁾ [Nm]				
	at 200 bar	158	258	376
at 350 bar	278	453	658	
Input power [kW]	continuous	27	54	71
	intermittent ⁴⁾	34	67	89
Weight [kg]	7.2	8.5	12.5	

- 1) Theoretical values
- 2) Valid at an inlet pressure of 1.0 bar (abs.) when operating on mineral oil at a viscosity of 30 mm²/s (cSt).
- 3) Valid with 2 1/2" inlet (suction) line. With 2" suction line:
 T1-81 – max 1400 rpm (Q ≈ 120 l/min);
 T1-121 – max 950 rpm (Q ≈ 120 l/min).
- 4) Max 6 seconds in any one minute.

NOTE:
 For noise level information, contact Parker Hannifin.

Pump cross section

(T1-51 shown)

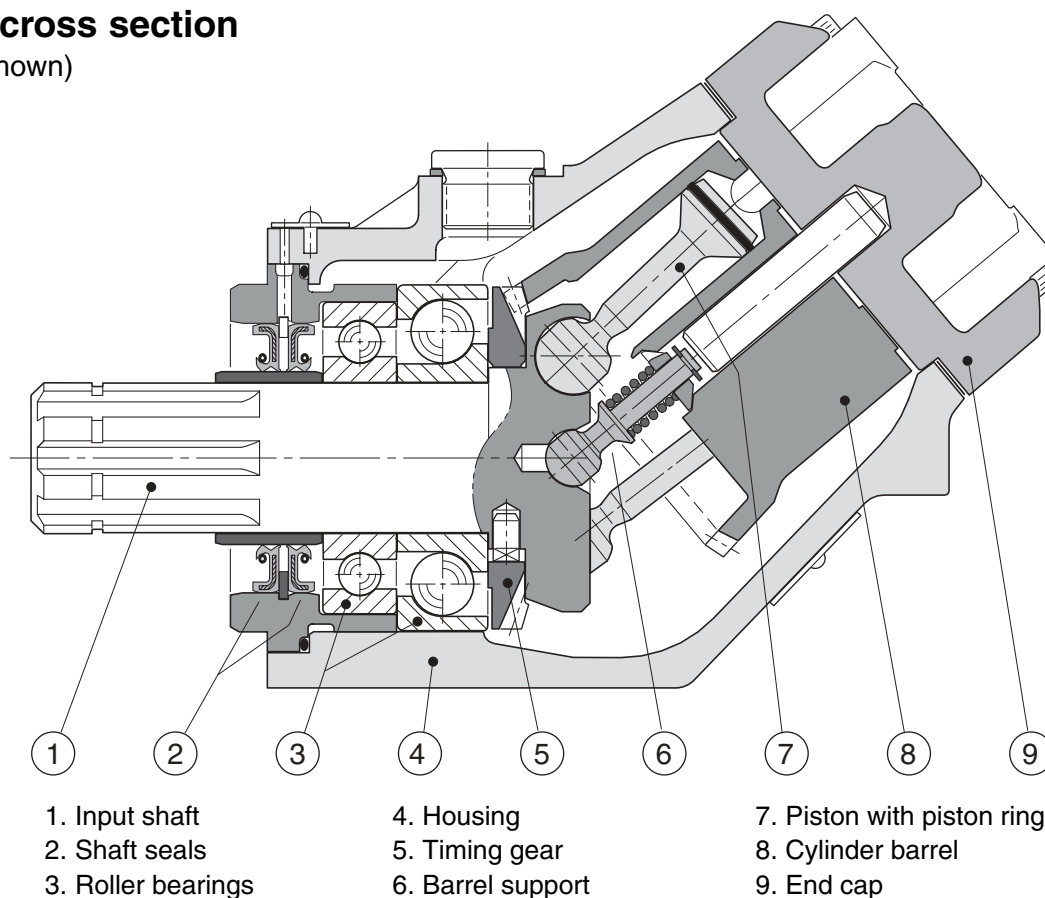

Installation dimensions, T1-51

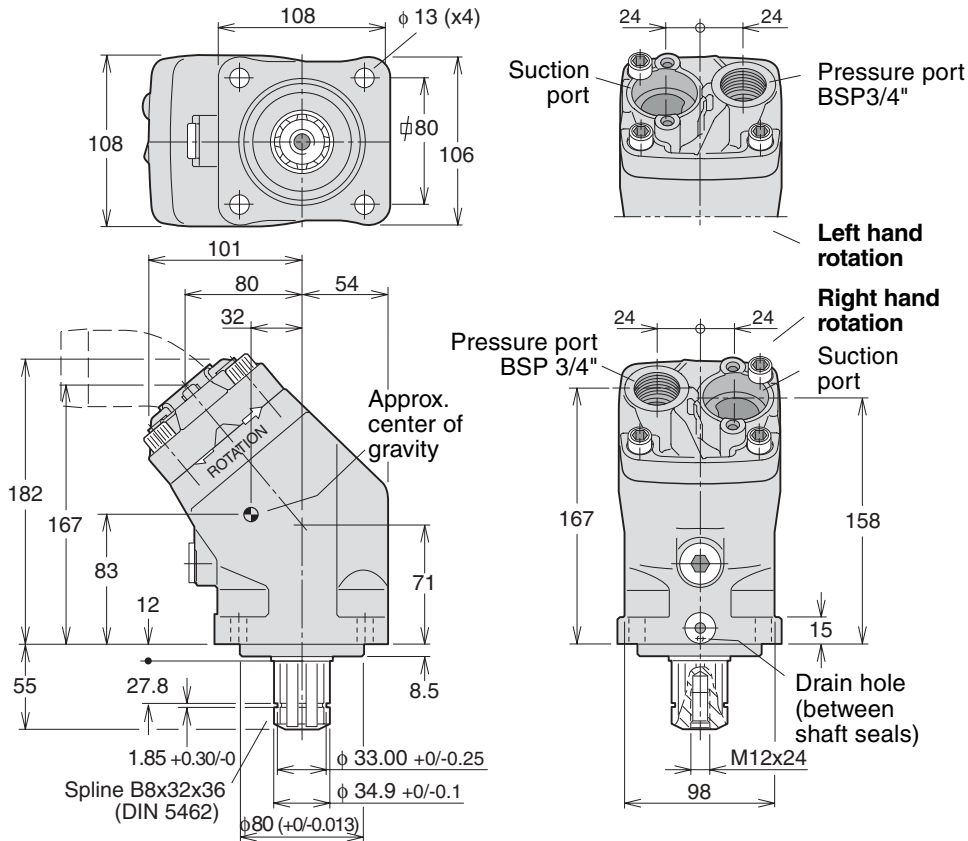

Installation dimensions, T1-81

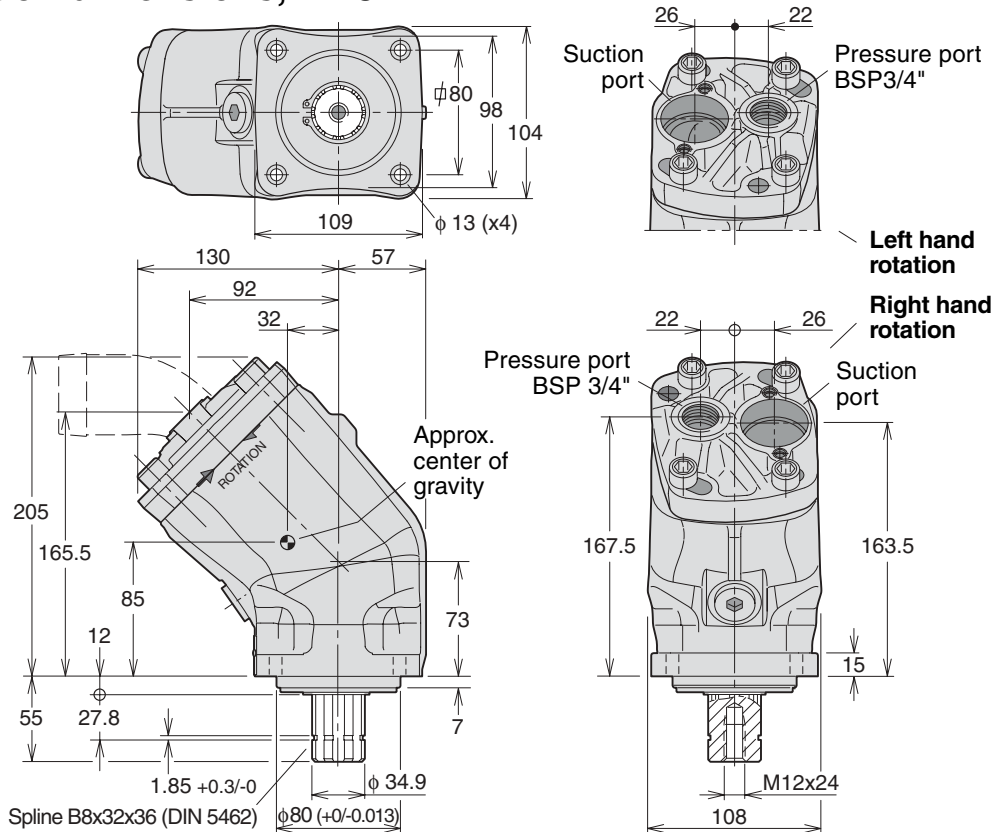

Installation dimensions, T1-121

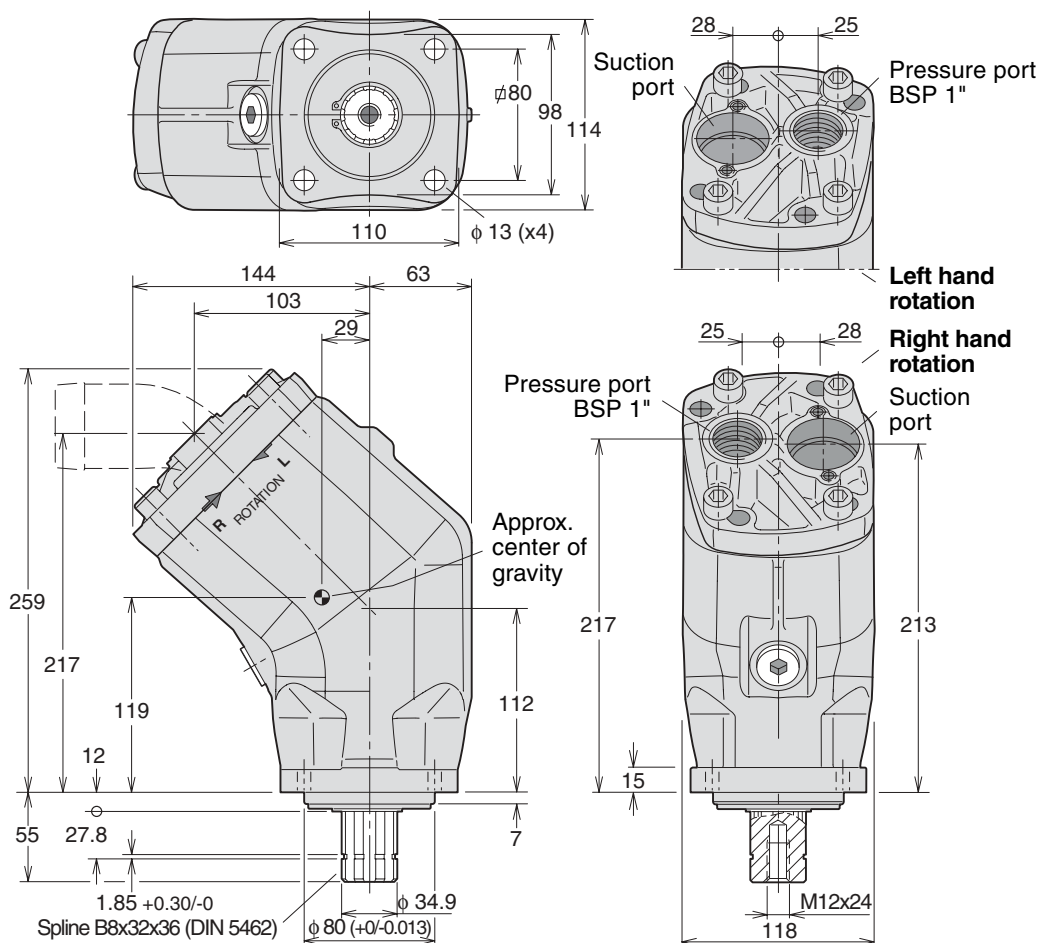

Ordering code

Example: **T1 - 81 - R**

T1 frame size **51, 81 or 121**

Shaft rotation
R Right hand
L Left hand

Standard versions

Designation	Ordering no.
T1-51-R	378 2250
-L	378 2251
T1-81-R	378 2180
-L	378 2181
T1-121-R	378 2120
-L	378 2121

Port size

T1 frame size	Pressure port ¹⁾
-51	3/4"
-81	3/4"
-121	1"

1) BSP thread (fitting not included).

NOTE: The T1 pump **does not** include a suction fitting; it must be ordered separately. See chapter 9.

BLA

General information

The BLA boost unit simplifies the building of closed or semi-closed hydrostatic transmissions.

Main features are:

- Replaces conventional charge pump and corresponding valves in many applications
- Allows pump speeds above normal selfpriming speed
- Suitable for system flow rates to 400 l/min
- Includes filter
- Simple construction - no moving/wear parts
- Cost-effective installation
- Small tank size
- Helps in building a low-cost hydrostatic transmission.

Description

In a closed circuit hydrostatic transmission, a charge pump is normally included with the main pump, providing make-up fluid which replaces pump and motor volumetric losses. It also maintains sufficient pump inlet pressure to avoid cavitation.

The BLA boost unit replaces the charge pump in many applications, when the following conditions are met:

- The max-to-min pump flow ratio does not exceed 2:1
- System pressure changes gradually without frequent and pronounced pressure peaks
- The line length between pump and boost unit is relatively short.

There are two basic sizes of the BLA boost unit:

- BLA 4 (to 160 l/min pump flow)
- BLA 6 (to 400 l/min).

The main part of the unit is an aluminium housing with a built-in nozzle and an injector; refer to the cross section to the right.

When fluid flows from the motor outlet port through the unit and to the pump inlet port, the increased fluid velocity between the nozzle and injector creates a low pressure zone causing additional fluid to be drawn from tank into the main circuit.

Also, pressure increases after the injector, allowing the pump to be operated at speeds higher than the self-priming speed. The 'boost pressure' increases with flow.

The housing includes ports that should be connected to the pump and motor drain ports respectively.

An additional bleed-off nozzle diverts approx. 10% of the main flow through the cartridge filter before being directed to the tank.

Typical applications:

- Fan drives
- Propeller drives
- Generator drives
- Pump drives.

Oil cooling

An oil cooler is usually required in the hydraulic system, in order to remove the heat that is generated in the main circuit. A full-flow oil cooler should be installed in the return line between the motor and the boost unit.

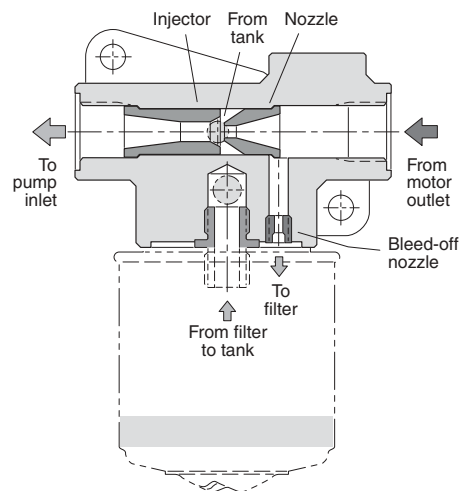

BLA boost unit cross section.

Boost unit installation

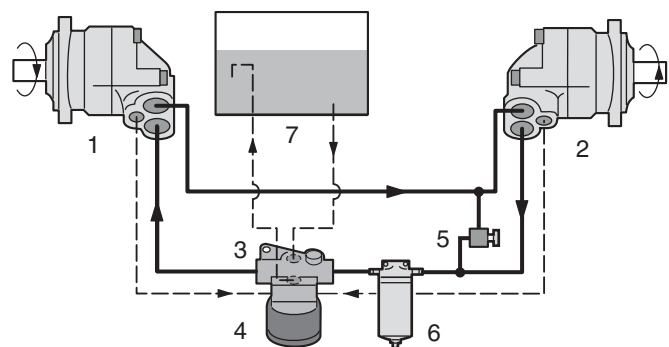

- | | |
|--|-------------------------------------|
| 1. Pump | 5. Pressure relief valve |
| 2. Motor | 6. Full-flow filter (when required) |
| 3. Boost unit (with injector and nozzle) | 7. Reservoir |
| 4. Filter cartridge | |

For more information please see our technical catalogue BLA boost unit HY17-8224/UK

Fittings

Suction fittings

for series F1, F2 and T1 pumps

A 'suction fitting' consists of a straight, 45°, 90° or 135° suction fitting, 2 clamps, 2 cap screws and an O-ring.

'Straight' suction fittings

Ordering no.	A mm	B mm	C dia. mm (in.)
378 0635	0	85	38 (1½")
378 0636	17	136	50 (2")
378 0637	25	145	63 (2½")
378 0973	17	136	45
378 0974	17	136	48

45° suction fittings

Ordering no.	A mm	B mm	C dia. mm (in.)
378 1234 ¹⁾	60	104	32 (1¼")
378 0633 ¹⁾	60	104	38 (1½")
378 0364 ²⁾	67	110	50 (2")
378 0634	75	117	63 (2½")
378 1062	67	110	40
378 0975	67	110	45
378 0965	67	110	48

1) Suitable for frame size F1-25.

2) Suitable for pump sizes F1-41,-51,-61,-81 and -110.

90° suction fittings

Ordering no.	A mm	B mm	C dia. mm (in.)
378 0978	126	83	38 (1½")
378 0979	135	83	50 (2")
378 0976	135	83	45
378 0977	135	83	48
378 1980	147	103	63 (2½")

135° suction fitting

Ordering no.	A mm	B mm	C dia. mm (in.)
378 1867	166	73	50 (2")

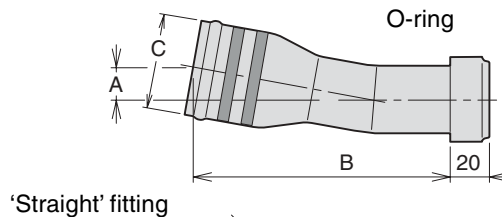
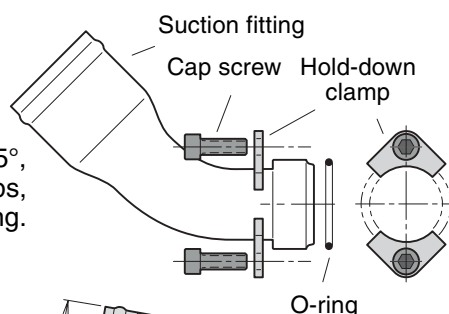

'Straight' fitting

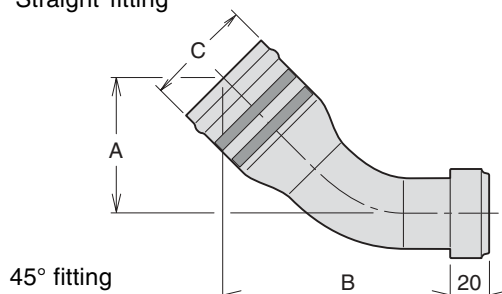

45° fitting

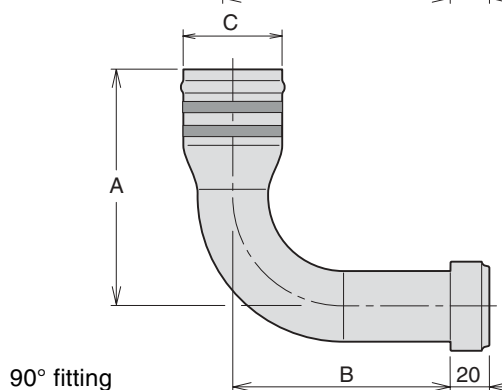

90° fitting

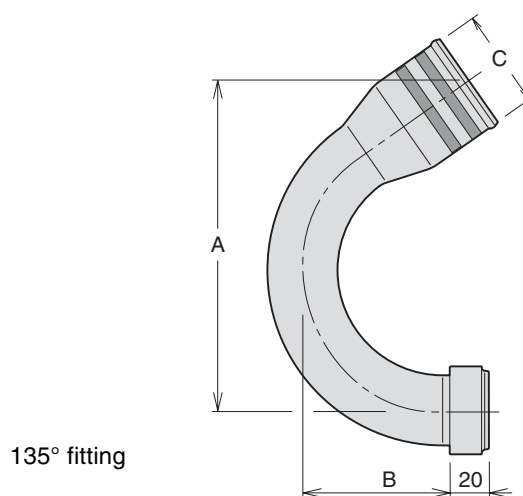

135° fitting

NOTE: A suction fitting *must be ordered separately* (not included with the pump).

Fitting kits

for series F1 and VP1 pumps

Kits with straight suction fitting

Pump size	Ordering no.	C ₁	C ₂ dia.
F1-20/-30	370 4934	BSP 1/2"	1 1/2"
F1-40/-60	370 4935	BSP 3/4"	2"
F1-80/-110; VP1	370 4936	BSP 3/4"	2"
F1-80/-110; VP1*	370 7220	BSP 1"	2"

* Above 100 l/min

Pressure fitting

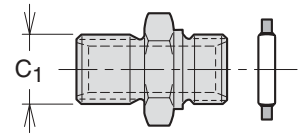

Straight suction fitting

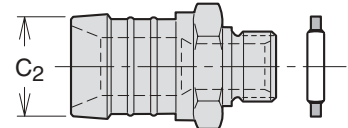

Kits with 45° suction fitting

Pump size	Ordering no.	C ₁	C ₂ dia.
F1-20/-30	370 9017	BSP 1/2"	2"
F1-40/-60	379 9564	BSP 3/4"	2"
F1-80/-110; VP1	379 9563	BSP 3/4"	2"
F1-80/-110; VP1*	379 9562	BSP 1"	2 1/2"

Pressure fitting

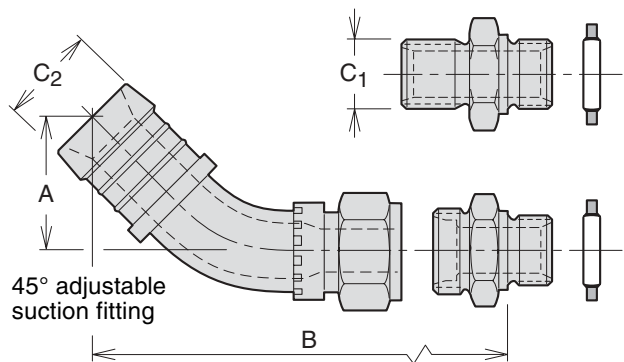

45° adjustable suction fitting

Pump size	A	B
F1-20/-30	71	154
F1-40/-60	"	"
F1-80/-110; VP1	"	"
F1-80/-110; VP1*	64	147

* Above 100 l/min

Pressure fitting

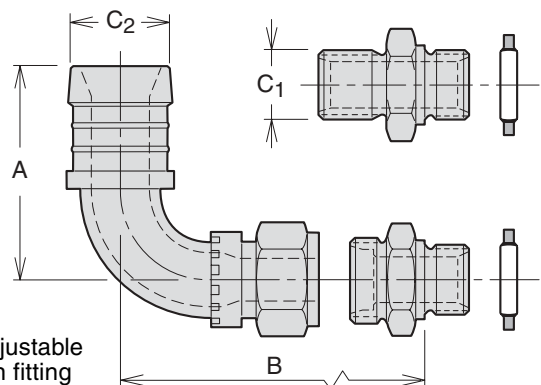

90° adjustable suction fitting

Kits with 90° suction fitting

Pump size	Ordering no.	C ₁	C ₂ dia.
F1-20/-30	379 9915	BSP 1/2"	2"
F1-40/-60	379 9916	BSP 3/4"	2"
F1-80/-110; VP1	379 9918	BSP 1"	2"

Pump size	A	B
F1-20/-30	144	128
F1-40/-60	"	"
F1-80/-110; VP1	"	"

NOTE: Each kit consists of a pressure fitting, a suction fitting, and corresponding seal washers.

Auxiliary Valves

**Bypass Valves for
F1, F2, T1 and VP1
pumps**

Contents

Bypass valve:

- BPV-F1 -25 and -81
- BPV-F2
- BPV-F1/-T1
- BPV-T1
- BPV-L, line mounted
- BPV-VP1

Unloading valve:

- ES line mounted unloading valve

Accessories

- MB-F2-H1 torque limiting valve

BPV-F1-25 and -81 bypass valve

- The bypass valve is mainly utilized in applications where the F1 pump is driven from the crank-shaft through a cardan shaft, or when it is installed on an engine PTO.
- The BPV bypass valve should be engaged during transportation when the pump is operating constantly and the engine is running at max rpm; the hydraulic system is not sized for the large flow that would otherwise go through it.
- The BPV valve substantially reduces the energy loss during transportation.
- The valve installs directly on top of the pump end cap with a pressure port 'banjo' fitting and an inlet port spacer bushing with two cap screws; refer to the illustration to the right.
- As the BPV valve is symmetrical, it can be 'turned 180°' to prevent interference with chassis components; it can be utilized for either left hand or right hand pumps.
- The valve function must only be activated or released (by means of the 24 VDC solenoid) at *no-load* (below 20 bar) *system pressure*.

IMPORTANT INFORMATION

- In order to prevent heat build-up in the pump during transportation, it is important that at least 5 l/min comes out of the filter at 'q' (refer to the schematic). This applies to an 'open center' system when the valve is in the bypass mode (non-activated solenoid).
- *Please note:*
 - a) If the flow at 'q' is less than 5 l/min (caused e.g. by a high pressure drop in the main system) when the valve is in the bypass mode, or
 - b) if the hydraulic system is of the 'closed center' type, then
an external drain line **must be installed** from the bypass valve drain port directly to tank as shown in the schematic; a drain kit is available (see below).

Bypass valve, type **BPV-F1-25/-81**

Max pressure, continuous [bar]	350
intermittent [bar]	400
Solenoid voltage [VDC]	24
Power requirement [W]	17
Operating mode	Activated solenoid: Check valve closed

Bypass valve kits	Ordering number	For F1 size	Torque press. connector to:
BPV-F1-25, 24 VDC	378 1401	-25/-41/	50 Nm
12 VDC	378 1318	-51/-61	
BPV-F1-81, 24 VDC	378 1402	-81/-101	100 Nm
12 VDC	378 1319		
O-ring kit	378 0641	Contains all five O-rings (as illustrated to the right); included in all valve kits	
Drain fitting kit	378 1640	Contains a drain line fitting and a bonded seal.	

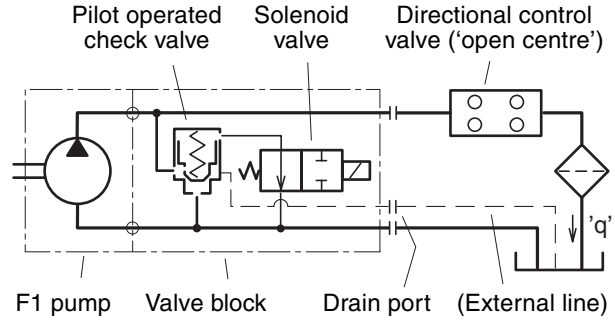

Bypass valve schematic.

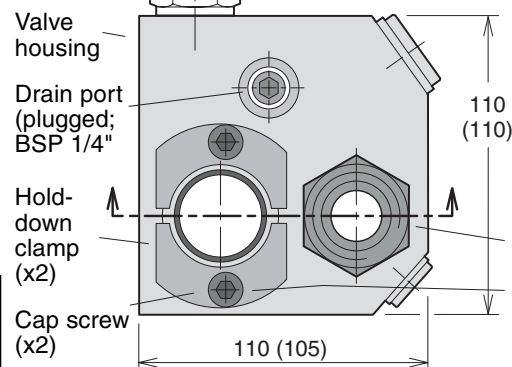
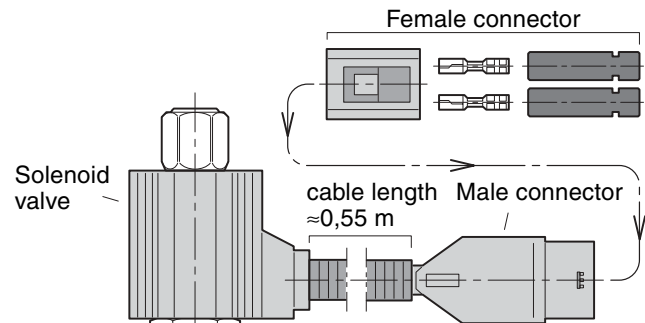
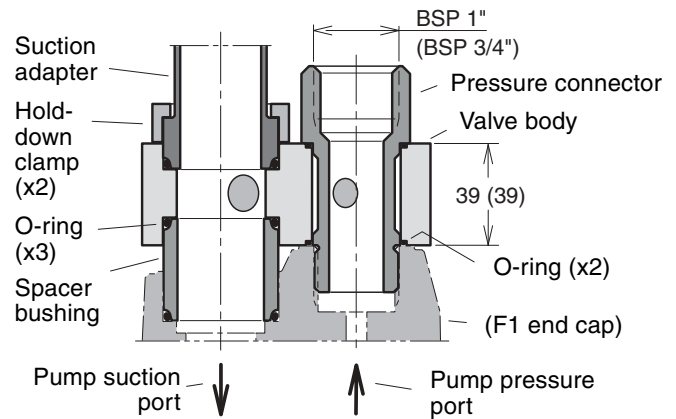

IMPORTANT: Always tighten the pressure connector before tightening the cap screws. Also see table to the left.

NOTE: Dimensions are shown for BPV-F1-81 (those for BPV-F1-25 are in paranthesis)

Bypass valve installation and cross section.

BPV-F2 bypass valve

- An F2 twin pump fitted with a bypass valve can be utilized in applications where the pump is operating constantly i.e. when the pump is driven from the crankshaft through a propshaft, or when it is installed on a PTO. In addition, it can be used when, temporarily, one of the two circuits is not required; the power loss is thus reduced as the non-required flow is not forced through lines and 'open center' valves.
- In most cases, the bypass valve allows the pump to be driven at max engine rpm during transportation at a minimum load. This prevents pump cavitation and high heat generation which may otherwise be encountered at large flows.
- The BPV valve connects the outlet and inlet ports of the pump, and only a small oil flow goes through the system and to the reservoir.
- The valve is installed directly on top of the pump port surface with 'banjo' fittings and two cap screws (refer to the split view to the right).
- As the BPV valve is symmetrical it can be 'turned 180°' so as not to interfere with chassis components. The valve can accommodate left hand as well as right hand rotating pumps.
- The valve can only be engaged or disengaged (through the 24 or 12 VDC solenoid) at low system pressures (below 20 bar).

IMPORTANT INFORMATION

- In order to secure a cooling flow through the system, a separate drain line **must** be connected from the BPV-F2 drain line fitting (shown in the split view) directly to tank; refer also to the schematic.
- The pressure connectors must be tightened (to 50 Nm) before the suction fitting clamp screws are tightened.

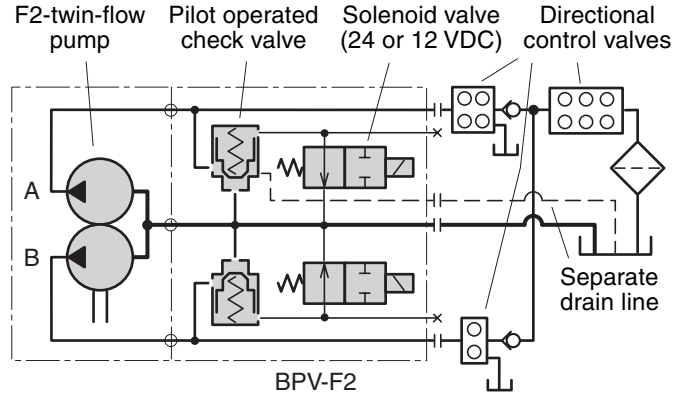

Bypass valve circuit schematic (example).

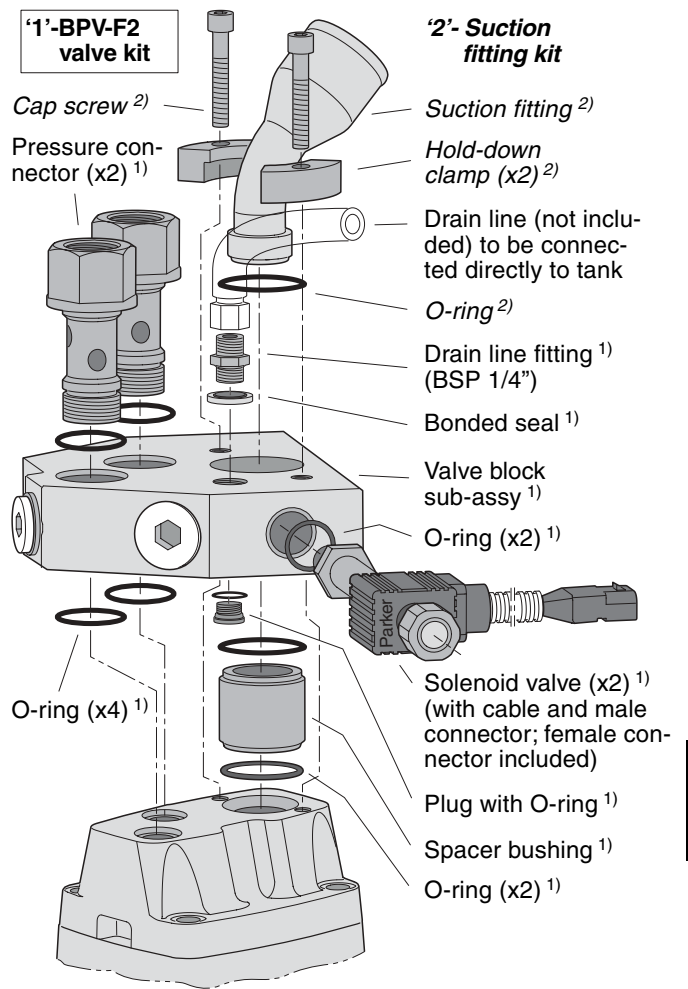

Bypass valve split view (with F2 end cap).

NOTE: A suction fitting kit (parts designated '2' in the split view) is **not** included with the F2 pump; it must be ordered separately (refer to chapter 9).

Bypass valve, type	BPV-F2	
Max operating pressure [bar]	350	
Solenoid voltage [VDC] standard (optional)	24 (12)	
Power requirement [W]	17 (each solenoid)	
Operating mode	Activated solenoid: Check valve closed	
Bypass valve kits	Ordering number	Torque press. connector to:
BPV-F2, 24 VDC	378 1459	50 Nm
12 VDC	378 1567	
O-ring kit	378 0641	Contains all five O-rings (as illustrated to the right); included in all valve kits

1)The BPV-F2 valve kit contains parts designated '1' in the split view to the right.

2) Contains all O-rings shown in the split view .

BPV-F1/-T1 bypass valve

- An F1 or T1 pump supplied with a bypass valve can be utilized in applications where the pump is operating constantly i.e. when the pump is driven from the crankshaft through a propshaft or belt, or when it is installed on a PTO.
- In most cases, the bypass valve allows the pump to be driven at max engine rpm during transportation at no load. This prevents pump cavitation and high heat generation which may otherwise be encountered at large flows.
- The BPV valve connects the outlet and inlet ports of the pump, and only a small oil flow goes through the system to tank.
- The valve is installed directly on top of the pump port surface with 'banjo' fittings.
- As the BPV valve is symmetrical it can be 'turned 180°' to suit either left hand or right hand pump rotation, or to prevent interference with chassis components.
- The valve can only be engaged or disengaged (through the 12 or 24 VDC solenoid) at no-load system pressure.

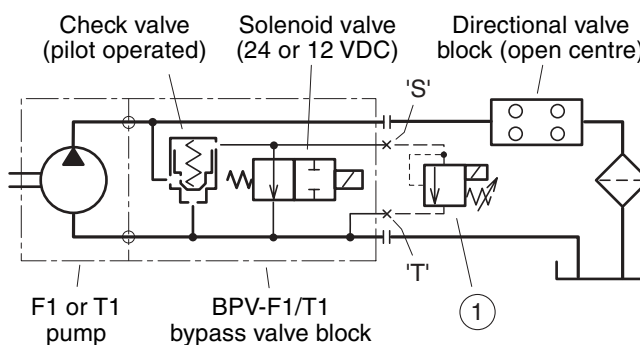
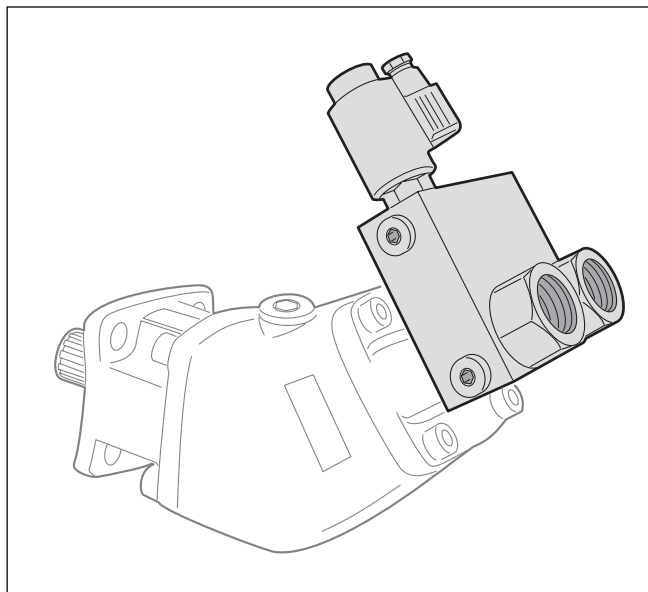

1. To limit system pressure, a 1/4" relief valve (not included) can be installed between pilot gauge port S and inlet gauge port T.

Bypass valve, type	BPV-F1/-T1
Max operating pressure [bar]	350
Solenoid voltage [VDC] standard (optional)	24 (12)
Power requirement [W]	17
Operating mode	Activated solenoid: Check valve closed

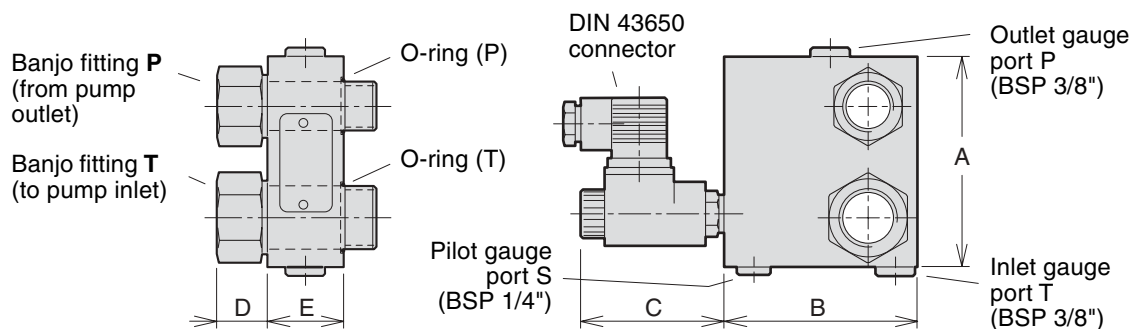

Bypass valve designation	Ordering number		Dimensions [mm]					BSP thread		Torque [Nm]	
	24 VDC	12 VDC	A	B	C	D	E	T	P	T	P
BPV-F1-20/30	379 2123	—	105	100	74	26	40	3/4"	1/2"	50	50
BPV-F1-40/60	370 8086	379 7508	115	100	74	26	40	1"	3/4"	50	50
BPV-F1-80	379 1962	379 7509	130	100	74	26	40	1 1/4"	1"	100	100
BPV-F1-110	370 8088	379 8775	140	100	74	26	40	1 1/4"	1"	100	100
BPV-T1-50	379 4472	—	115	100	74	26	40	1"	3/4"	50	50
O-ring kit	379 9883	Contains banjo fitting O-rings for the above valves.									

BPV-T1-51/81 and -121 bypass valve

- The bypass valve is mainly utilized in applications where the T1 pump is driven from the crankshaft through a cardan shaft, or when it is installed on an engine PTO.
- The BPV bypass valve should be engaged during transportation when the pump is operating constantly and the engine is running at max rpm; the hydraulic system is not sized for the large flow that would otherwise go through it.
- The BPV valve substantially reduces the energy loss during transportation.
- The valve installs directly on top of the pump end cap with a pressure port 'banjo' fitting and an inlet port spacer bushing with two cap screws; refer to the illustration to the right.
- As the BPV valve is symmetrical, it can be 'turned 180°' to prevent interference with chassis components; it can be utilized for either left or right hand pumps.
- The valve function must only be activated or released (by means of the 24 VDC solenoid) at *no-load* (below 20 bar) *system pressure*.

IMPORTANT INFORMATION

- In order to prevent heat build-up in the pump during transportation, it is important that at least 5 l/min comes out of the filter at 'q' (refer to the schematic). This applies to an 'open center' system when the valve is in the bypass mode (non-activated solenoid).
- *Please note:*
 - a) If the flow at 'q' is less than 5 l/min (caused e.g. by a high pressure drop in the main system) when the valve is in the bypass mode, or
 - b) if the hydraulic system is of the 'closed center' type (with a shunt), then
 an external line **must be installed** from the bypass valve drain port directly to tank as shown in the schematic; a drain fitting kit is available (below).

Bypass valve, type **BPV-T1-51/81 and -121**

Max pressure, continuous [bar]	200
intermittent [bar]	350
Solenoid voltage [VDC]	24 or 12
Power requirement [W]	17
Operating mode	Activated solenoid: Check valve closed

Bypass valve kits	Ordering number	Torque pressure connector to:	
BPV-T-51/81, 24VDC	378 1401	50 Nm	Also see fig. to the right
12VDC	378 1318	" "	
BPV-T1-121, 24VDC	378 1402	100 Nm	"
12VDC	378 1319	" "	
O-ring kit	378 0641	Contains all five O-rings (as illustrated to the right); included in all valve kits	
Drain fitting kit	378 1640	Contains a drain line fitting and a bonded seal.	

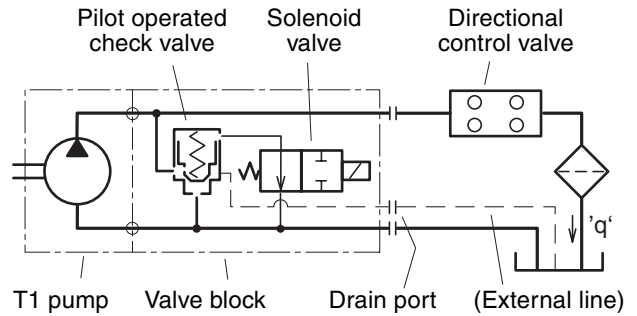

Bypass valve schematic.

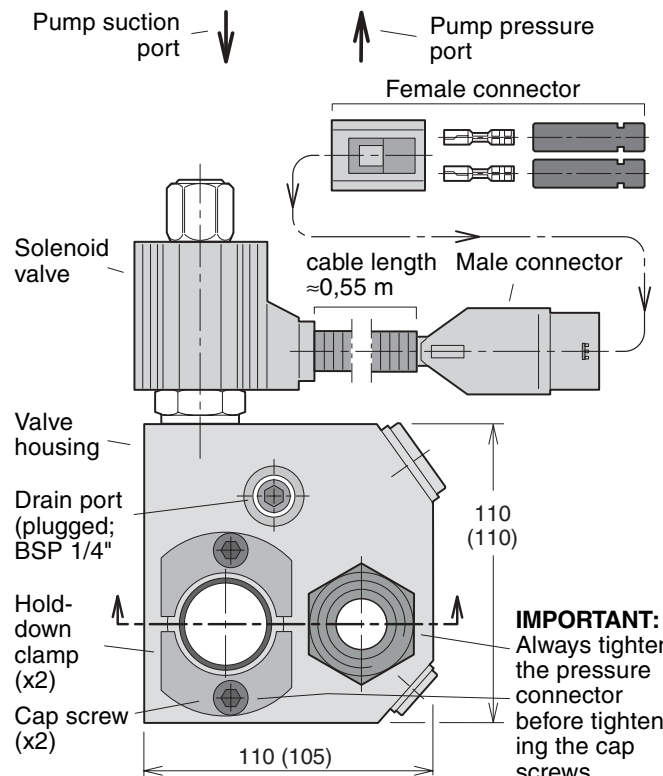
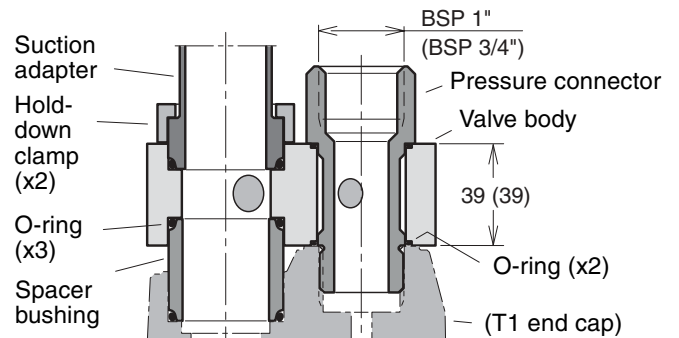

IMPORTANT: Always tighten the pressure connector before tightening the cap screws. Also see table to the left.

NOTE: Dimensions are shown for BPV-T1-121 (those for BPV-T1-81 are in paranthesis)

Bypass valve installation and cross section.

BPV-L line mounted bypass valve

- The unloading valve is utilized in hydraulic systems where the fixed displacement pump is engaged constantly and no flow is required, i.e. during transportation. The flow is directed through the unloading valve which has a low pressure loss and less heat is being generated in the system.
- When the solenoid is activated the unloading valve closes and the pump flow is directed to the directional control valve or other user.

Unloading valve, type	BPV-L
Max operating pressure [bar]	350
Max flow [l/min]	250
Solenoid voltage [VDC]	24
Required power [W]	17
Operating mode	Activated solenoid: Check valve closed
Ordering number	378 1487

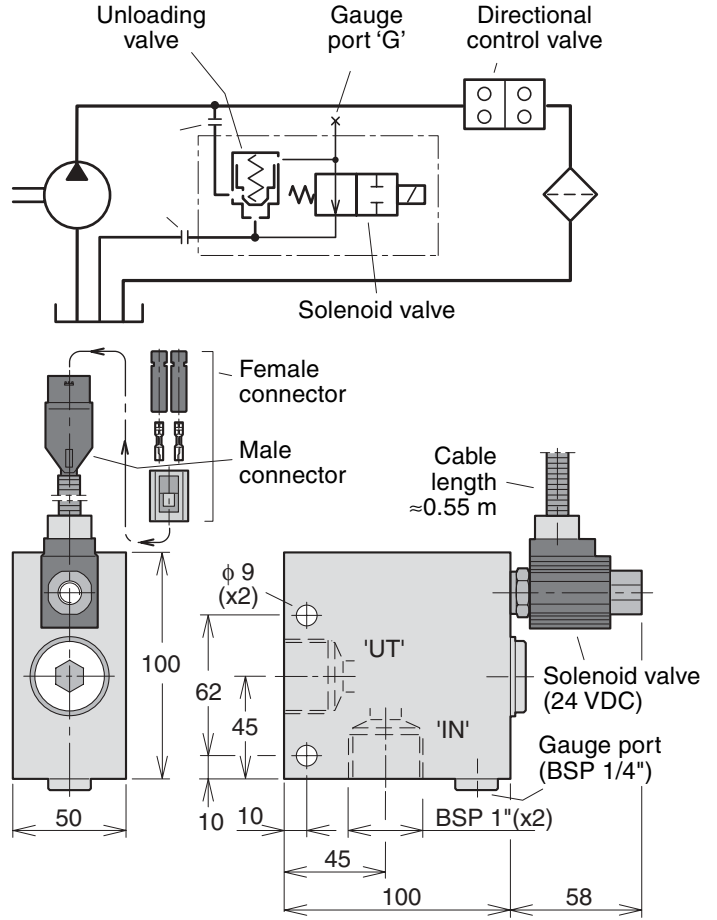

BPV-VP1 unloading valve

The BPV-VP1 unloading valve is utilized in hydraulic systems where the pump is operating constantly. The valve, which requires no additional control valve, allows the pump to operate on- or off-load up to its max selfpriming speed.

The valve protects the pump from overheating in the off-load mode by allowing a small flow through the pump (refer to the schematic to the right). When a load sensing valve function is engaged, the bypass flow is cut off (as port 'X' is being pressurized).

Valve type	Ordering number	Rated flow [l/min]	Max press. [bar]
BPV-VP1	379 8799	20	350

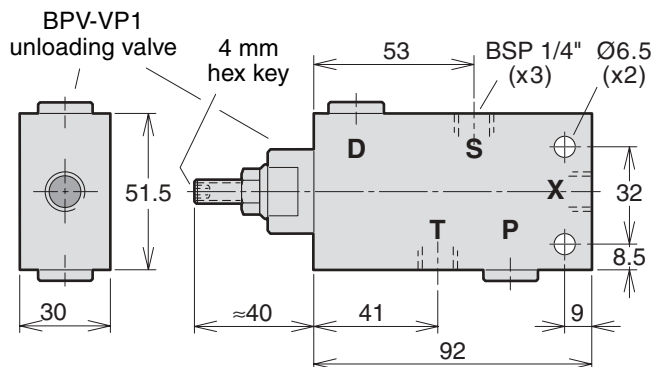
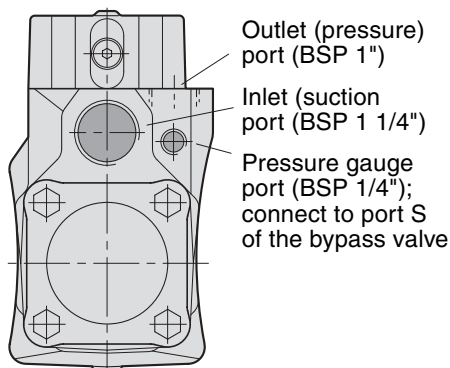
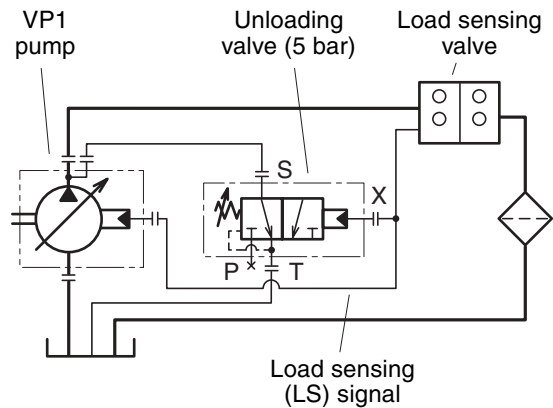

ES line mounted unloading valve

- The ES unloading valve is intended for hydraulic circuits with a fixed or variable displacement pump. The valve is available in two versions:
 - ES-CFO (for a system with a fixed displacement pump and a directional valve type CFO)
 - ES-LS (for a load sensing system with a variable displacement pump and a dir. control valve type LS).
- The valve block installs with M10 screws (alt. with M8 screws and nuts); main ports are BSP 1".
- The ES valve has a built-in, adjustable pressure relief valve (3).
- ES-CFO system function: When the solenoid is non-active (refer to the schematic below left) the entire pump flow goes through port T to tank and port P2 is blocked. An activated solenoid allows flow through the valve from P1 to P2.

- ES-LS system function: When the solenoid is being de-activated, the pump goes to min displacement and the reduced flow is directed through port T to tank; port P2 is blocked (refer to the schematic below right). When the solenoid is activated, the required pump flow goes through the valve from P1 to P2.

Unloading valve design.	ES-CFO	ES-LS
Max operating press. [bar]	350	
Max flow [l/min]	200	
Solenoid voltage [VDC]	24*	
Required power [W]	12	
Non-activated solenoid:	P1-to-T1	
Activated solenoid:	P1-to-P2	
Ordering number	376 6684	376 7031

* A 12 VDC solenoid is optional; contact Parker Hannifin.

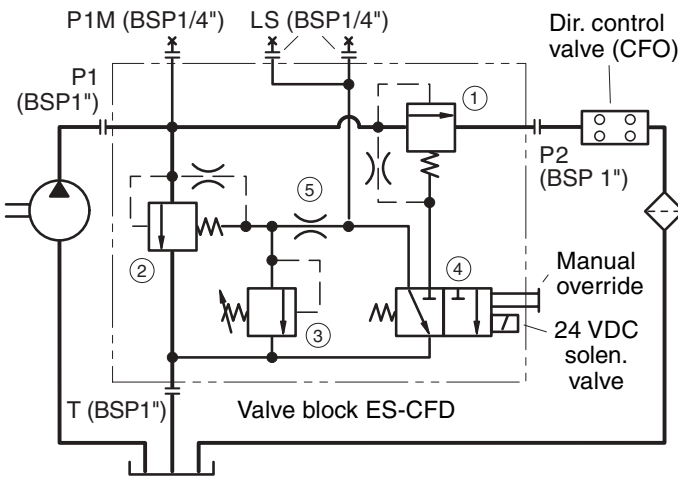

Hydraulic schematic - CFO system (example).

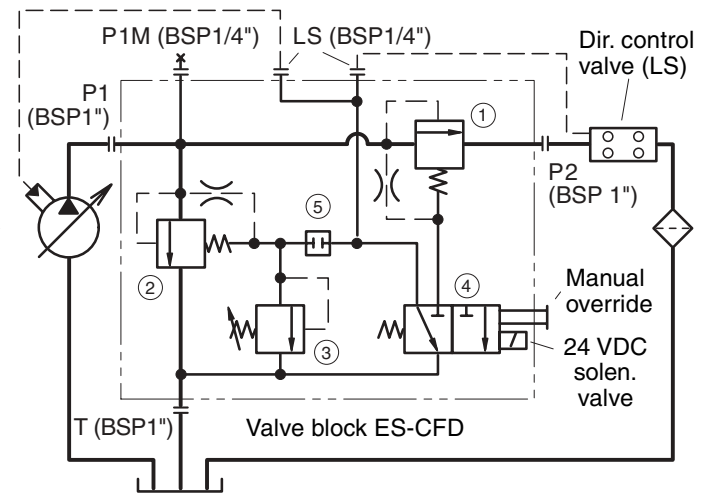

Hydraulic schematic - LS system (example).

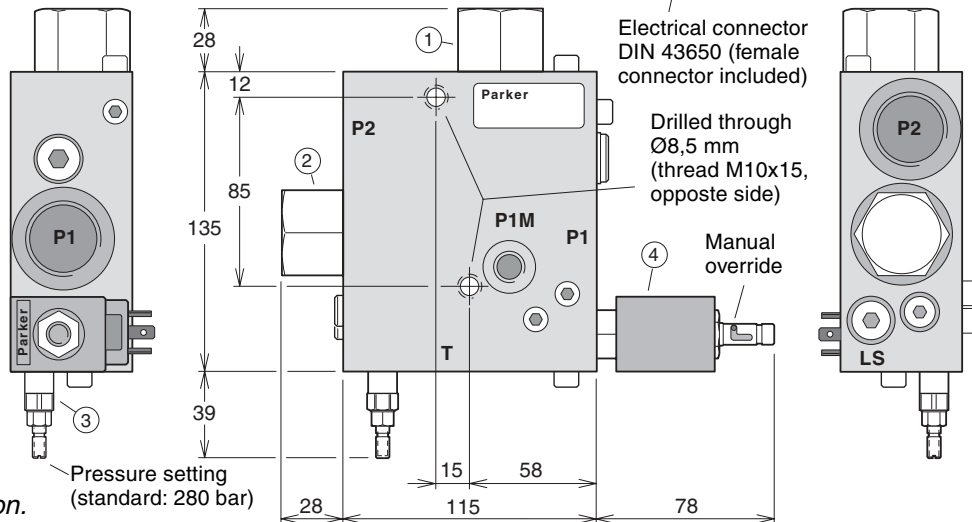
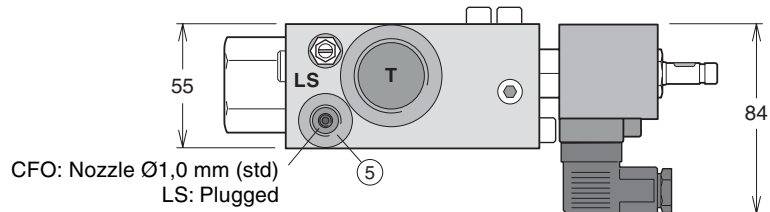

Installation information.

MB-F2-H1 torque limiting valve

The torque limiting valve protects the PTO output shaft (which drives the hydraulic pump) from being overloaded. When the set pressure in the system is reached, the flow from the pump circuit connected to the valve is being unloaded; refer to the schematic.

Pressure drop

The diagram below shows pressure drop (P-to-T) vs. flow when the set pressure is reached and the valve unloads one of the pump flows to tank.

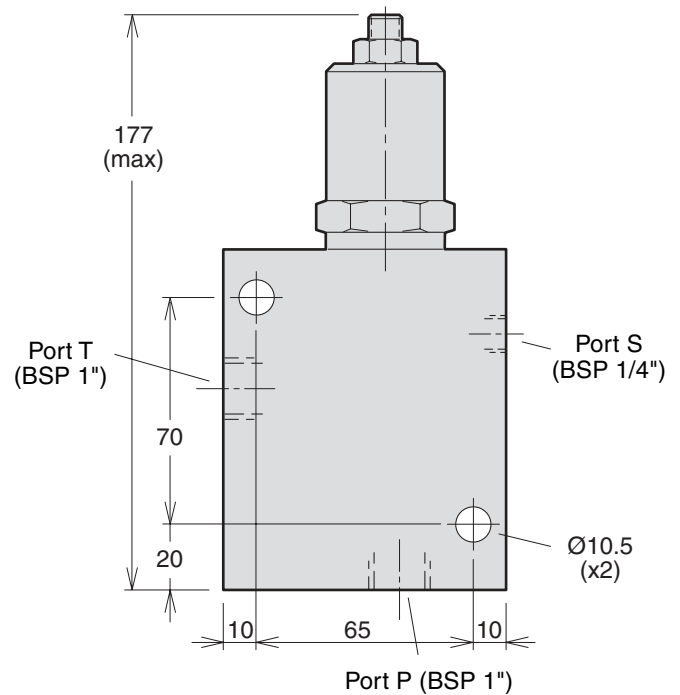
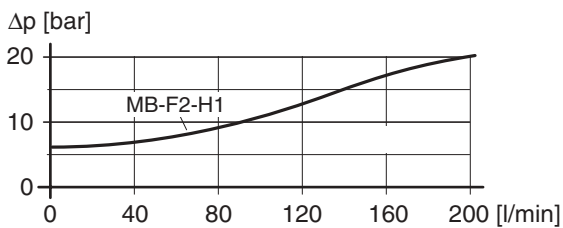

Application examples

The following schematics show how the MB valve can be connected to the F2.

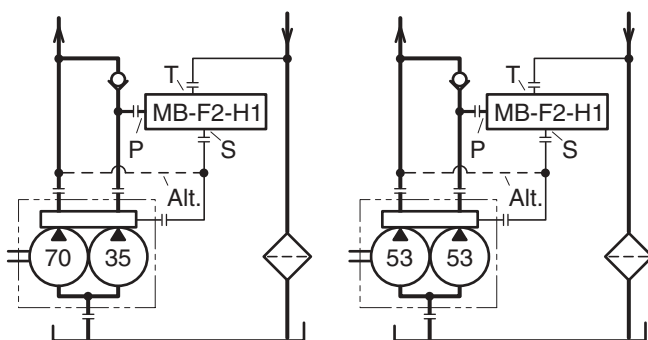

MB-F2-H1 valve for system pressures to 350 bar (application examples)

Torque limiting valve	MB-F2-H1
Max pressure [bar]	350
Adjustment range [bar]	150 – 350
Ordering number	378 0202

Accessories

Adapter kits and accessories for F1, F2, T1 and VP1 pumps

Contents

PTO Air valve kits:

- Volvo PTO's
- Scania PTO's
- Universal

PTO adapter kits:

- for Scania ED 90 engines
- for Scania ED 120 engines
- for Scania ED 140 engines
- for Scania ED 160 engines
- for Mercedes engines (Actros)
- ES, line mounted unloading valves

Cardan shafts, pump couplings and mounting brackets .

Pump couplings

Return filter and filter indicator

Air breather filter

Check valves

SB splitter boxes

10

11

Air valve kit for Volvo PTO's

- The air valve kit is suitable for operating a Volvo PTO on Series FM and FH truck chassis (FH introduced Nov. -98). All parts required to operate the PTO are included in the kit (as shown below).
- The air valve can be combined with other air valves on the chassis; this means a simple installation with a common air supply and a minimum of hoses.
- All electrical wires are pre-installed on the chassis. The relay should be installed in socket K1-14 behind the dashboard cover.
- Function:
 The relay makes sure the PTO is being disengaged as soon as the 'ignition key' is turned off.
 To re-engage the PTO, the operator has to put the switch back to neutral, and then move it to the 'ON' position.



Air valve kit for Volvo PTO's.

PTO air valve kit	Volvo
Air valve nominal voltage [VDC]	24
Nominal current [A]	0.4
Required power [W]	9.6
Max air pressure [bar]	10
Air hose size	1/4"
Operating mode	Activated solenoid: Air valve open and PTO engaged.
Ordering number, series FM and FH ¹⁾	378 1010

1) Series FH(c) introduced Nov. -98.

Air valve kit for Scania PTO's

- All parts required for operating a Scania PTO are included in the kit (shown below).
- The air valve kit is suitable for all Scania chassis, Scania Original PTO's, and PTO's from Parker Hannifin for Scania chassis.
- The air valve can be combined with other air valves on the chassis; this means a simple installation with a common air supply and a minimum of hoses.
- All electrical wires are pre-installed on the chassis.

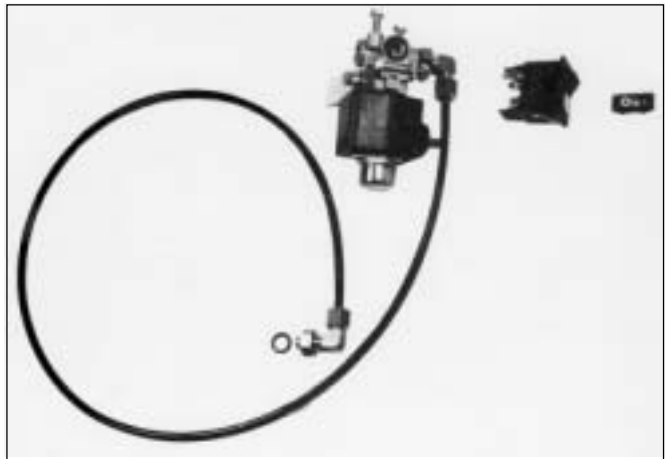

Air valve kit for Scania PTO's.

PTO air valve kit	Scania
Air valve nominal voltage [VDC]	24
Nominal current [A]	0.4
Required power [W]	9.6
Max air pressure [bar]	10
Air hose size	1/4"
Operating mode	Activated solenoid: Air valve open and PTO engaged.
Ordering number	370 5215

Universal PTO air valve kit

- The kit includes all parts required for maneuvering the PTO.
- The air valve kit is suitable for most PTO's with a metric M12x1.5 air connection.
- The air valve can be installed with other air valves on the chassis which means simple installation with common air supply and a minimum of hoses.
- The air valve can be connected to electrical wires usually pre-installed on the chassis.

PTO air valve kit	Universal
Air valve nominal voltage [VDC]	24
Nominal current [A]	0.4
Required power [W]	9.6
Max air pressure [bar]	10
Air hose size	1/4"
Operating mode	Activated solenoid: Air valve open and PTO engaged.
Ordering number	370 8779

PTO adapter kit for Scania ED 90 engines

- With the adapter kit, an hydraulic pump that meets the ISO standard can be installed on PTO of the Scania 9 liter engine DS/DSC 9.
- The PTO must be ordered with the chassis from Scania.
- For additional information please refer to Scania Service Information 19-86 03 30 GT SV.

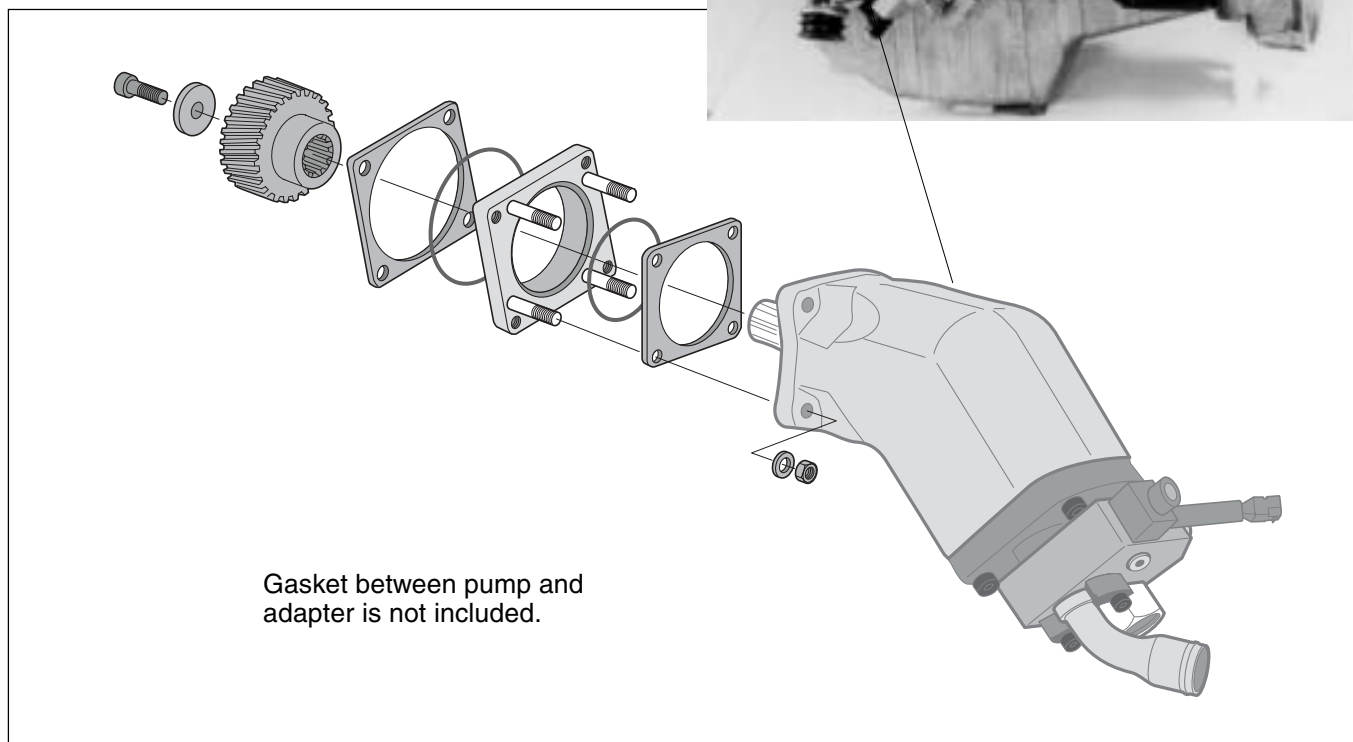
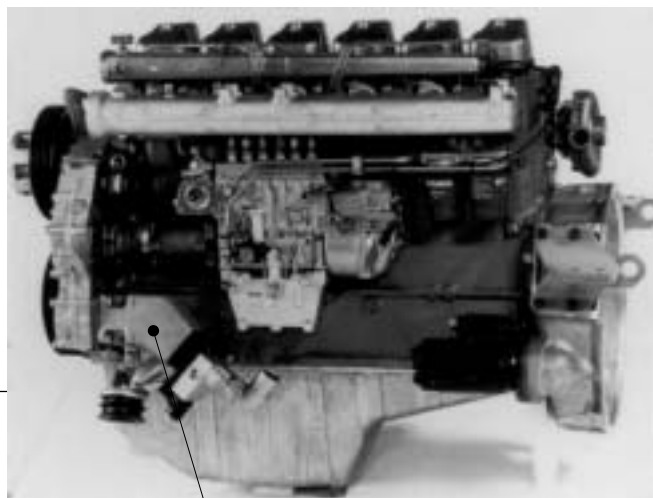

Pump size	F1-25	F1-41	F1-51	F1-61	F1-81	F1-101	F2-53/53	F2-70/35
Max. operating pressure [bar]	350	350	350	350	223	235	220	220
Bypass valve	Required							

NOTE: Max operating pressures shown for the F2 frame sizes are valid when both ports are pressurized to the same level simultaneously.

Max. torque [Nm]	360
Gear ratio (engine:pump)	1 : 0.975
Pump rotation	Right hand (clockwise)

PTO adapter kit	Ordering number
Scania ED-90	379 1729

PTO adapter kit for Scania ED 120 engines

- With the adapter kit, an hydraulic pump (e.g. F1 or VP1) that meets the ISO standard can be installed on the PTO of the Scania 12 liter engine.
- The PTO gear is supplied with the chassis.
- **Please note:** The engine must be ordered with a PTO.

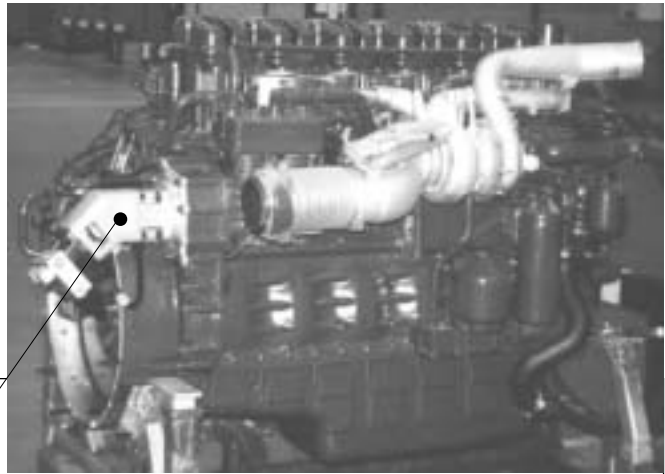

NOTE!
 When used on ED-120 the pump shall be mounted with the connections pointing “up”.
 (note necessary when the gear in the PTO has a supportbearing)

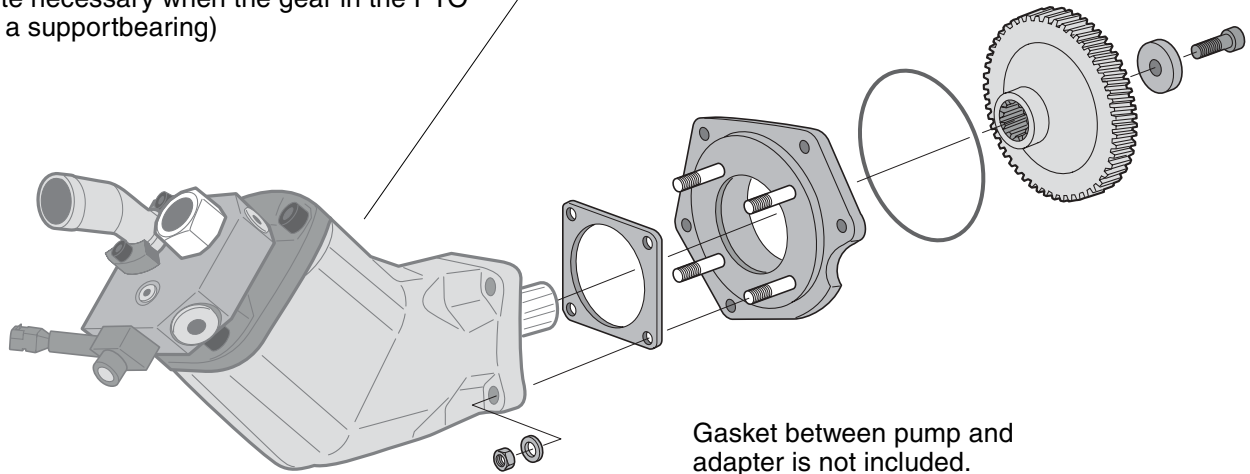

Pump size	F1-25	F1-41	F1-51	F1-61	F1-81	F1-101	F2-53/53	F2-70/35
Max. operating pressure [bar]	350			350			350	350
Bypass valve	Required							

NOTE: Max operating pressures shown for the F2 frame sizes are valid when both ports are pressurized to the same level simultaneously.

Max. torque [Nm]	600
Gear ratio (engine : pump)	1 : 1.19
Pump rotation	Right hand (clockwise)

PTO adapter kit	Ordering number*
ED-120-F1	378 2021
ED-120-VP1	378 2022

* Part numbers valid from 00-10-23 (W0043); replacing 379 9888 and 379 9889 respectively.

PTO adapter kit for Scania ED 140 engines

- With the adapter kit, an hydraulic pump that meets the ISO standard can be installed on PTO of the Scania 14 liter engine DS 14.
- The PTO gear is not supplied with the kit; it must be ordered separately. For model 144 and later it can be ordered either from Parker Hannifin, ordering number 379 9413, or from Scania Spare Parts.

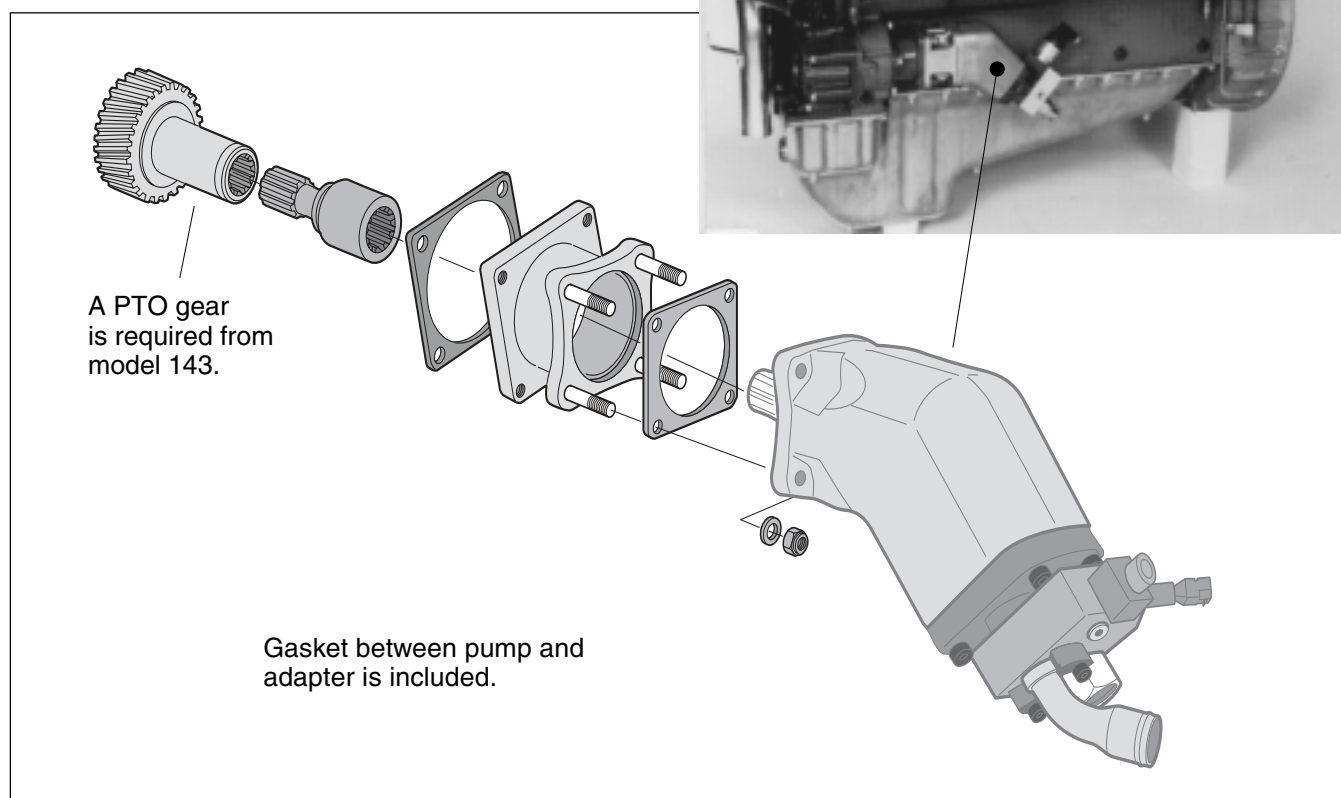
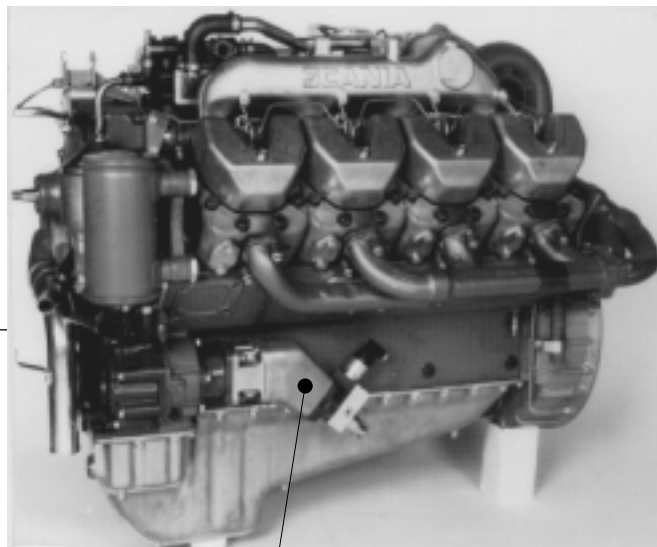

Pump	F1-25	F1-41	F1-51	F1-61	F1-81 ¹⁾
Max. operating pressure [bar]	350	350	285	200	150 ¹⁾
Bypass valve	Required				

1) The engine transmission permits only 150 bar on the F1-81.

Max. torque [Nm]	186
Gear ratio (engine-to-pump)	1 : 1
Pump rotation	Right hand (clockwise)

Designation	Ordering number
ED-140 adapter kit	370 8445
PTO gear (from model 144)	379 9413

NOTE: Model 143 also requires a PTO gear: Scania part no. 259 206.

PTO adapter kit for Scania ED 160 engines

- With the adapter kit, an hydraulic pump (e.g. F1 or VP1) that meets the ISO standard can be installed on the PTO of the Scania 16 liter engine.
- The PTO gear is supplied with the chassis.
- **Please note:** The engine must be ordered with a PTO.

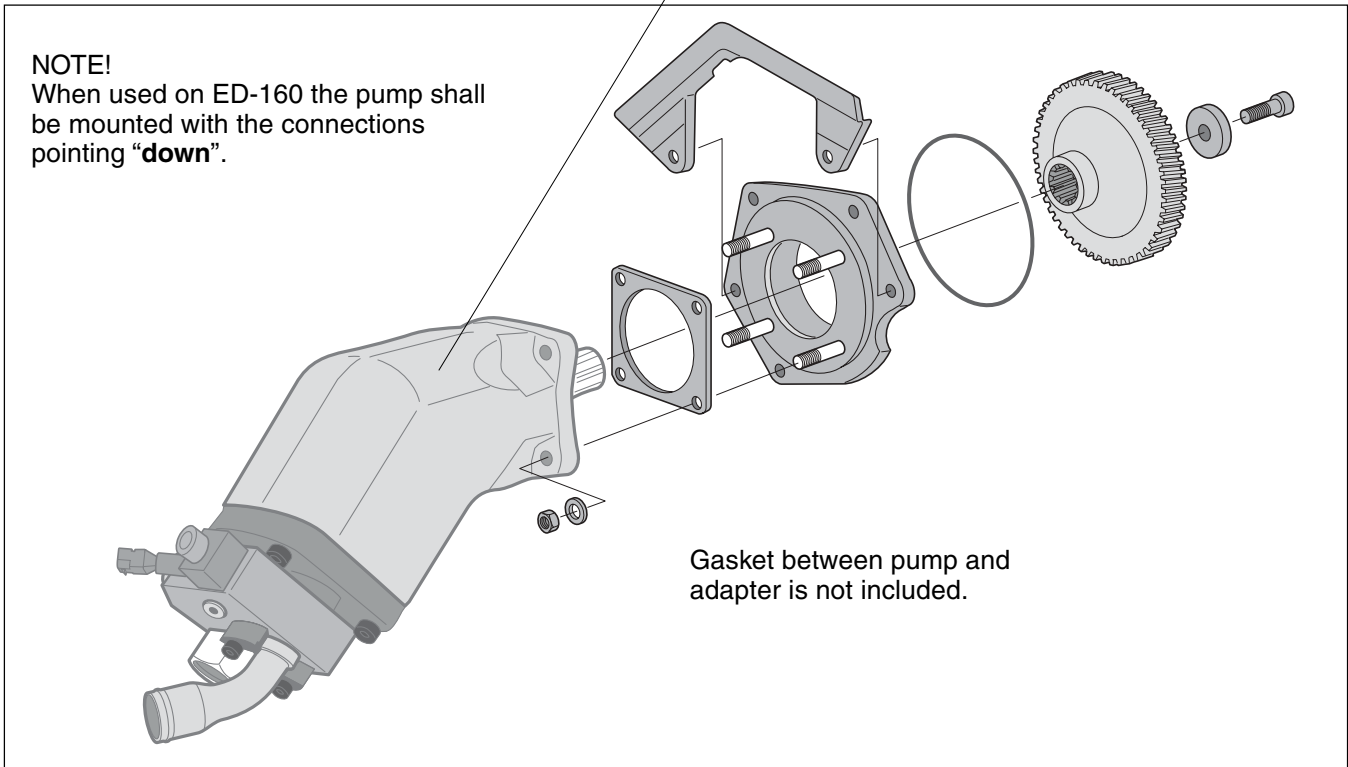

Pump size	F1-25	F1-41	F1-51	F1-61	F1-81	F1-101	F2-53/53	F2-70/35
Max. operating pressure [bar]	350			350			350	350
Bypass valve	Required							

NOTE: Max operating pressures shown for the F2 frame sizes are valid when both ports are pressurized to the same level simultaneously.

Max. torque [Nm]	600
Gear ratio (engine:pump)	1 : 1.19
Pump rotation	Left hand (counter clockwise)

PTO adapter kit	Ordering number
ED-160-F1	378 2001

PTO adapter kit for Mercedes engines (Actros)

- With the adapter kit, an hydraulic pump that meets the ISO standard can be installed on the PTO of the Mercedes V6 and V8 engines.
- The PTO must be ordered with the chassis from the manufacturer or through the distributor; when ordering, state 'N53 without pump'.

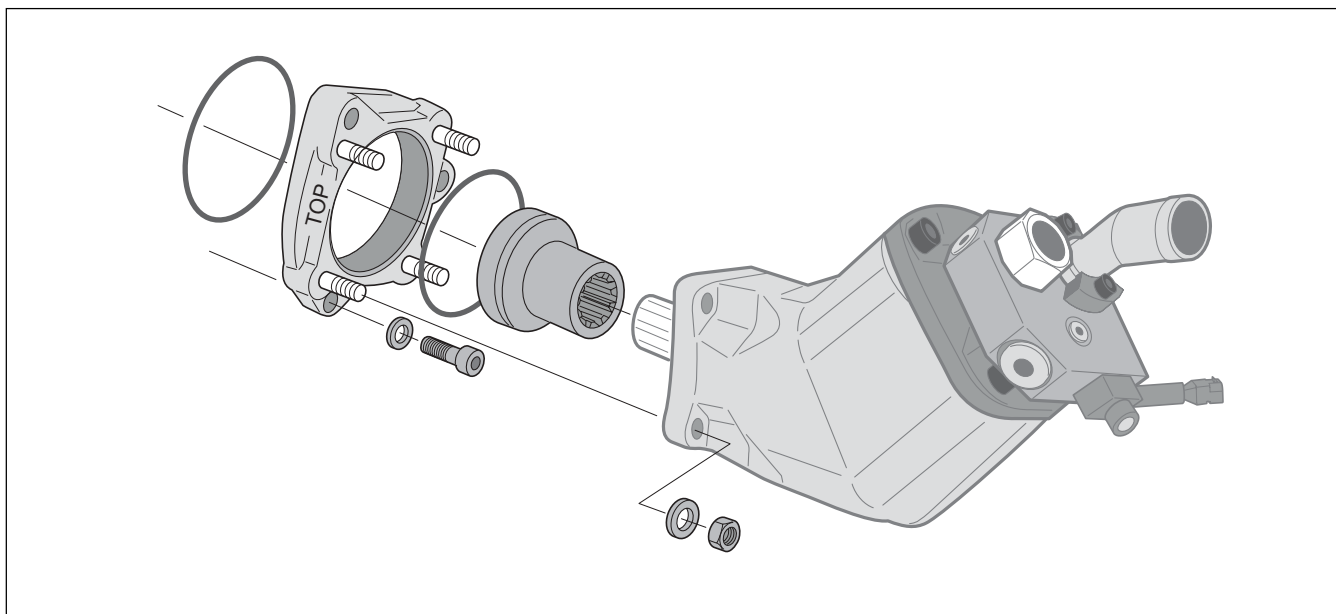

Pump	F1-25	F1-41	F1-51	F1-61	F1-81	F1-101
Max. operating pressure [bar] for short duration, non-frequent work cycles (e.g. tippers and skip loaders)	350	350	350	350	350	270
Max. operating pressure [bar] for continuous work cycles (e.g. cranes and winches)	350	350	350	350	310	225
Bypass valve	Required					

Pump	F2-53/53	F2-70/35	VP1-045	VP1-075
Max. operating pressure [bar] for short duration, non-frequent work cycles (e.g. tippers and skip loaders)	270	270	350	350
Max. operating pressure [bar] for continuous work cycles (e.g. cranes and winches)	230	230	300	300
Bypass valve	Required			

NOTE: Max operating pressures shown for the F2 frame sizes are valid when both ports are pressurized to the same level simultaneously.

Max. non-frequent/continuous torque [Nm]	470/390
Gear ratio (engine-to-pump)	1 : 1.075
Pump rotation	Right hand (clockwise)

Adapter kit	Ordering number
VH-PTO-DB	379 2568

Cardan shafts, pump couplings and mounting brackets

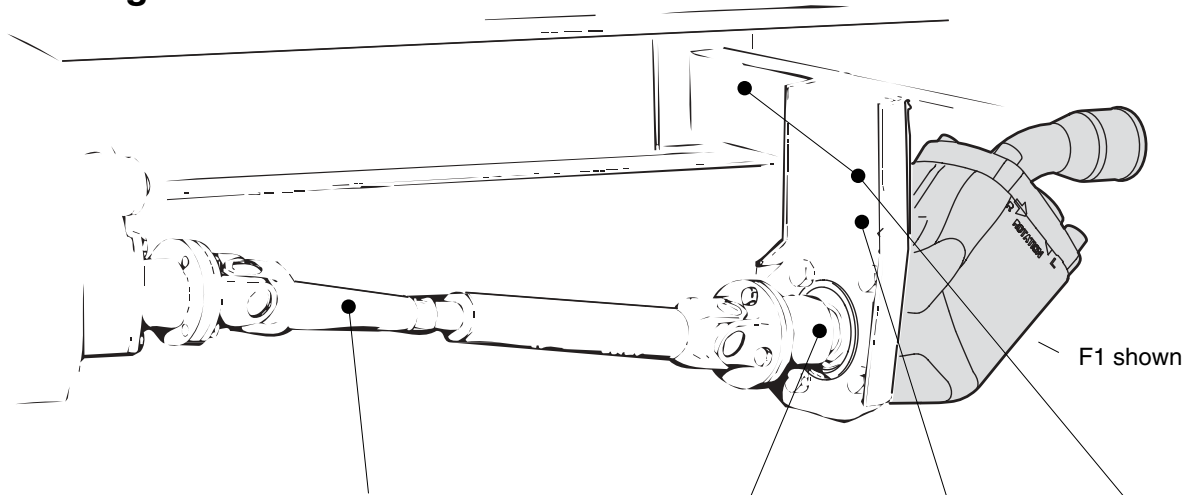

Pump or splitter box type	Cardan shaft kit Type	Cardan shaft kit Ordering no.	Pump coupling Type	Pump coupling Ordering no.	Bracket ordering no.	Bracket kit ordering no.
F1 ¹⁾	SAE 88 ¹⁾	073 001	SAE 88 ¹⁾	370 4628	379 7831	379 7832
F1 (New)	"	"	"	378 0644	"	"
F1 (New)	SAE 97	370 0315	SAE 97	378 0645	379 7831	379 7832
F1	"	"	"	370 4631	"	"
F2	"	"	"	"	"	"
T1-51	"	"	"	"	"	"
VP1	"	"	"	"	"	"
SB154, SB118	SAE 97	370 0315	SAE 97/ DIN 90	Included with splitter box	370 5221	370 5220

1) The SAE 88 cardan shaft and pump coupling can also be used to drive a series F2, T1-51 or VP1 pump providing max allowed shaft torque (below) is not exceeded.

Cardan shaft specifications

Cardan shaft type	Spicer designation	Max length [mm]	Diameter [mm]	Max torque peak/contin. [Nm]	Ordering number
SAE 88	K1140	1220 ²⁾	45	600/300	073 001
SAE 97	K1310	1220 ²⁾	50	1000/500	370 0315

2) One end not welded

PTO flange adapters

Cardan shaft type	PTO flange type	Flange adapter ordering no.
SAE 88	SAE 116	370 5895
SAE 97	SAE 116	370 5896
SAE 116	SAE 97	370 5897³⁾
DIN 90	DIN 100	370 5898
DIN 100	DIN 90	370 5899³⁾

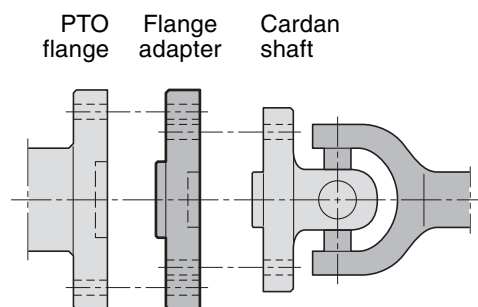

3) **WARNING!** The utilized cardan shaft torque limits (above) must not be exceeded.

Pump couplings

Designation	DIN 90 (fig. 1)
A	90
B	74.5
C	47 h7
D	M8
E ₁	61.5
VP1, F2, F1*	370 4634
F1	378 0642

NOTE: Max torque is limited by the cardan shaft.

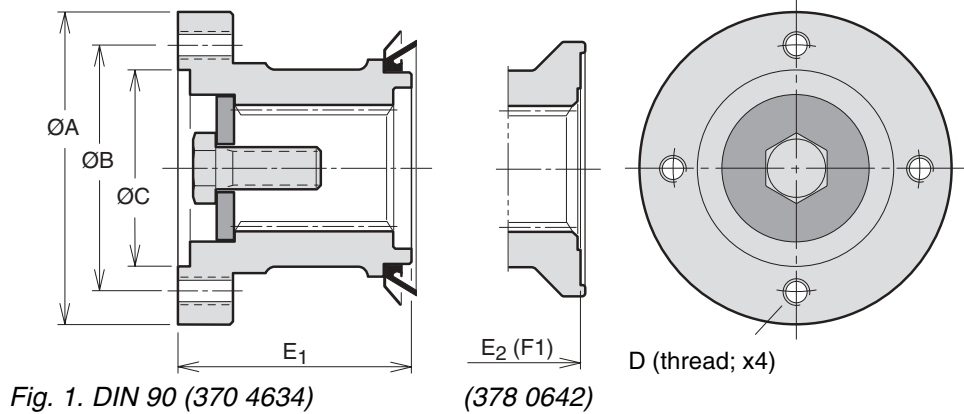

Designation	DIN 90 (fig. 2)
A	90
B	74.5
C	47 h7
D	8.2
E ₁	61.5
E ₂ (F1)	57.2
VP1, F2, F1*	370 7423

NOTE: Max torque is limited by the cardan shaft.

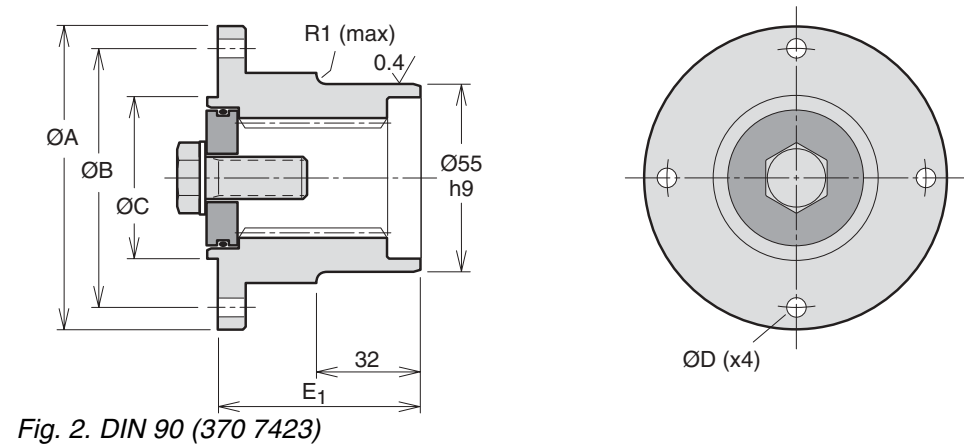

Designation	SAE88 (fig. 3)
A	88
B	69.9
C	57.15 H8
D	5/16" UNC
E ₁	65
E ₂ (F1)	59.5
Max torque [Nm] interm./contin.	600/300
VP1, F2, F1*	370 4628
F1	378 0644

NOTE: Max torque is limited by the cardan shaft.

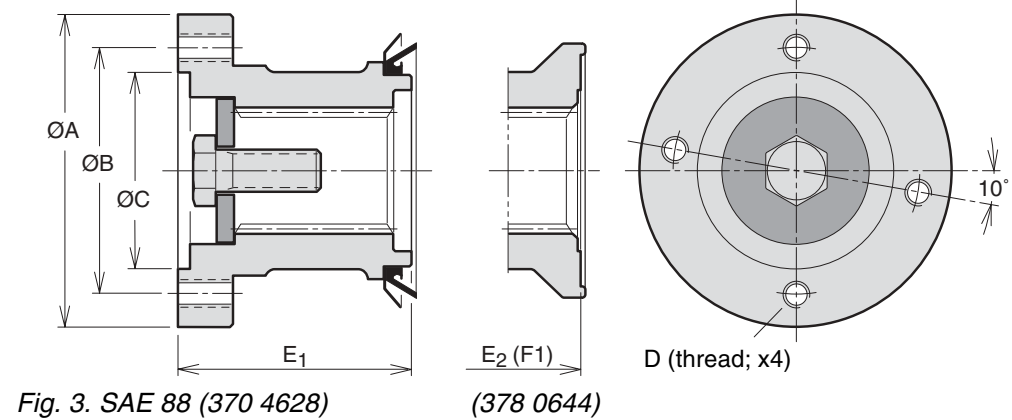

Designation	SAE97 (fig. 4)
A	97
B	79.4
C	60.33 H8
D	3/8" UNC
E ₁	65
E ₂ (F1)	59.5
Max torque [Nm] interm./contin.	1000/500
VP1, F2, F1*	370 4631
F1	378 0645

F1* Old versions

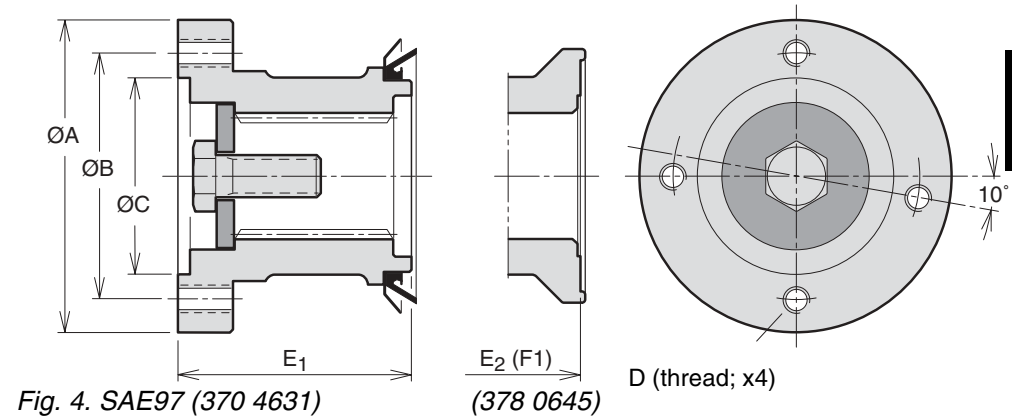

Return filter and filter indicator

Return flow filter

The low pressure, full flow return filter contains a replaceable fiber glass cartridge with a large flow area. The filter is designed for vertical installation on top of the hydraulic reservoir.

The built-in bypass function opens at 1.6 bar; the overflow is above the cartridge, preventing accumulated dirt inside the filter to enter the flow.

The aluminum housing contains three BSP 1/8" ports which can be utilized for the installation of a filter indicator (see below).

Designation	Return filter
Rated flow (at 30 cSt) [l/min]	230
Cartridge pressure drop at rated flow and 30 cSt [bar]	< 0.1
Degree of filtration ($\beta_{25} \cdot 75$, ISO 4572) [μm]	20 (abs.)
Cartridge collapse rating (ISO 2941) [bar]	8
Inlet port size	BSP 1 1/4"
Weight incl. cartridge [kg]	6
Ordering code, filter ass'y	946 395
filter cartridge only	946 396

NOTE: The flow capacity of the filter should be at least twice the pump flow under normal operating conditions.

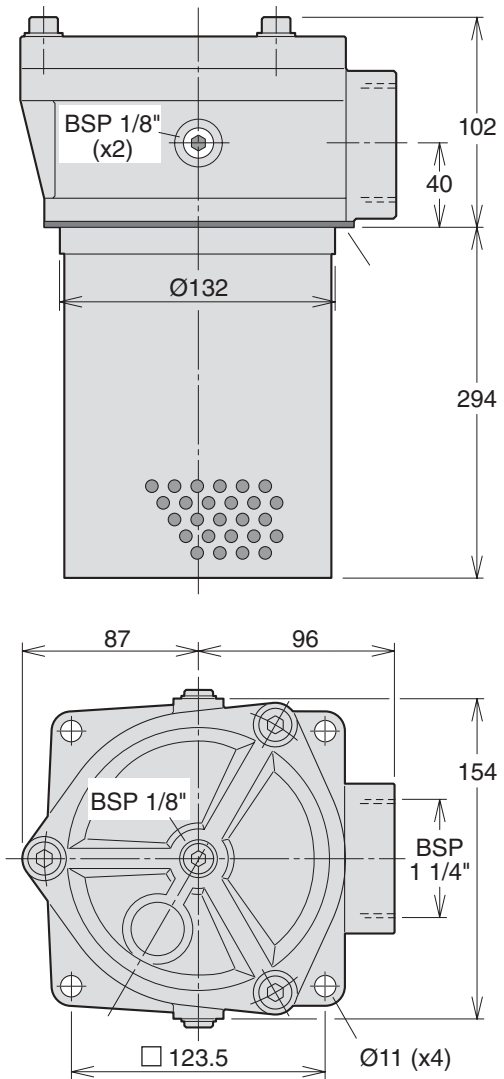

Filter indicator

The visual filter indicator installs in one of the filter housing ports (BSP 1/8"; see above). When the hydraulic system has reached normal operating temperature, the position of the indicator needle shows the condition of the filter cartridge:

- 'Green' - The cartridge is OK.
- 'Red' - Replace the cartridge.

NOTE: A needle in the red area indicates that only part of the oil flow is being filtered which, in turn, means that system components such as the pump will suffer from increased wear.

Designation	Filter indicator
'Green' pressure range [bar]	- 1.0
'Red' pressure range [bar]	1.0 – 1.6
Max pressure (peak) [bar]	2.5
Installation thread	BSP 1/8"
Ordering number	378 0191

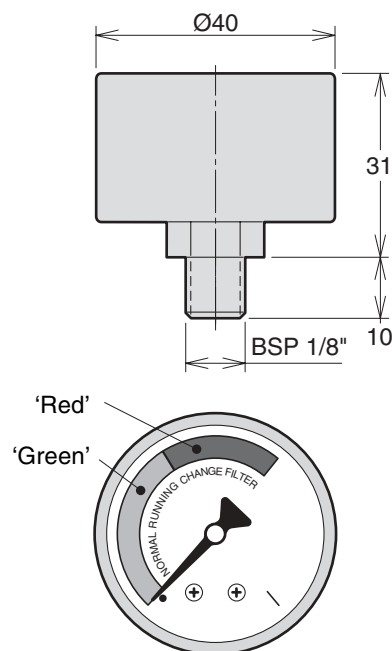

Air breather filter

The oil level in the reservoir can sink drastically when max pump capacity is utilized e.g. to fill the piston end of a cylinder with a large 'piston/piston rod' ratio and the return flow back to tank is comparatively small. A corresponding volume of air must then enter the tank through the breather.

The air breather shown to the right, which mounts on top of the reservoir, is adequately dimensioned for most applications. It has sufficient filtering properties to prevent external dirt from entering the hydraulic system.

The breather has a built-in function which limits the tank pressure to 0.5 bar.

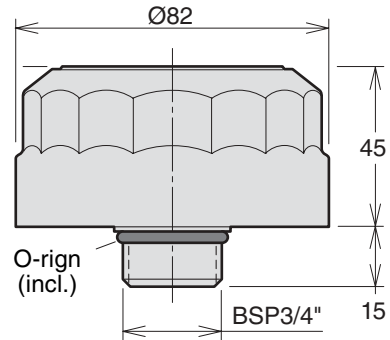

Designation	Air filter
Nominal air flow [l/min]	300
Nominal degree of filtration [μm]	6
Exhaust opening pressure [bar]	0.5
Installation thread	BSP 3/4"
Ordering number	378 0190

NOTE: Preferably, the air flow capacity should be at least twice the pump flow under normal operating conditions.

Check valves

Check valve	Ordering number	Max flow [l/min]	Max press. [bar]	Opening press. [bar]
1/2"	379 1963	75	350	0,5
3/4"	379 1964	130	350	0,5
1"	379 1965	200	350	0,5

Check valve	Dimensions in mm; B and C threads are BSP.						
	A	B	C	ϕ D	E	F	G
1/2"	32	1/2"	1/2"	30	19	35	69
3/4"	36	3/4"	3/4"	34	20	13	65
1"	40	1"	1"	43	20	15	70

NOTE: Free flow is indicated by the arrow.

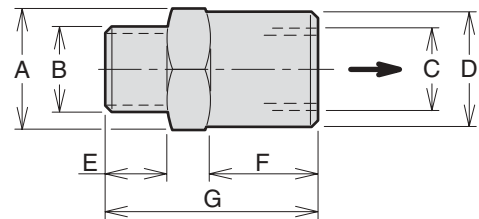

1/2" check valve

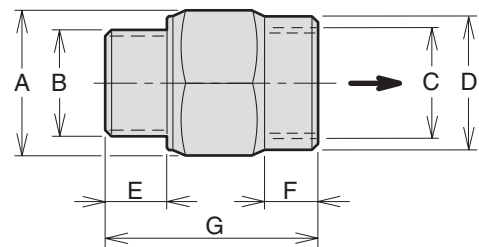

3/4" check valve

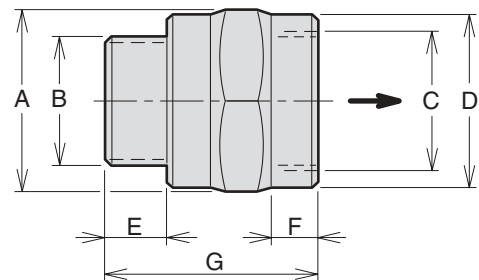

1" check valve

SB splitter boxes

- The splitter box is utilized to drive two pumps, providing two separate, independent flows.
- The high permissible input shaft torque allows two large pumps to be operated simultaneously; make sure, however, that the PTO and the cardan shaft will stand the intended load.
- Pump mounting flange and shaft end must meet the ISO standard.
- The splitter box is available with either of two gear ratios (input shaft-to-pump):
SB 118 - 1:1.18
SB 154 - 1:1.54
- The shipping carton contains all parts required for the installation of the two pumps.

Recommendations

Use the following tables to verify that max pump rpm and max splitter box input torque are not exceeded.

Pump size	Max input speed [rpm]	
	SB 118	SB 154
F1-20	1950	1500
F1-30	1700	1300
F1-40	1525	1200
F1-60	1300	975
F1-80	1100	850
F1-110	1100	850
T1-50	1350	1000

Example: An SB 118 with an F1-20 and an F1-80 can be operated at max 1100 rpm (splitter box input speed), and an SB 154 with the same pumps at max 850 rpm.

Pump size	Pump input torque [Nm] at		
	250 bar	300 bar	350 bar
F1-20	80	95	110
F1-30	120	140	165
F1-40	160	190	225
F1-60	240	285	335
F1-80	315	380	445
F1-110	435	525	610
T1-50	200	240	275
F2-53/53	420	505	590
F2-70/40	435	525	610

Example: An F1-40 at 350 bar requires 225 Nm and an F1-60 at 300 bar 285 Nm.

Total required splitter box input torque:

SB 118: (225 + 285) x 1.18 ≈ 610 Nm.

SB 154: (225 + 285) x 1.54 ≈ 785 Nm

Compare with max permissible torque (interm. 1000 Nm; continuous 700 Nm).

NOTE: If the splitter box should be utilized at close to the max permissible torque and/or max the permissible speed, please contact Parker Hannifin

Installation information

1. Series F1, T1 and F1 (fig. 2)

Valid: At continuous operation less than 30 min. and/or less than 80 kW continuous power output.

- Remove the uppermost drain plug and add 0.5 liter Shell Spirax AX (or similar fluid).
- Install the breather (and the 90° adapter, part no. 378 1069, if required).

NOTE: The F1 or T1 shaft seal **must not** be removed.

2. Series F1 and T1 (left illustration, fig. 3)

Valid: At continuous operation more than 30 min. and/or more than 80 kW continuous power output.

- Remove the shaft seals.
- Install a drain hose between the drain port on the side of the splitter box (see the illustr.) and the reservoir; it must end below the lowest oil level in the reservoir. Utilize one of the 'banjo' couplings included in hose kit 378 1085.

3. Series F1 (right illustration, fig. 3)

Valid: At continuous operation more than 30 min. and/or more than 80 kW continuous power output.

- Install hose kit 378 1085 between the lowest drain port on one of the pumps (see fig. 3) and the BPV-F1-25 och -81 avlastningsventiler lowest drain port of the splitter box.
- Install a drain hose between the drain port on the side of the splitter box and the reservoir; it must end below the lowest oil level in the reservoir. Utilize one of the banjo couplings included in hose kit 378 1085.

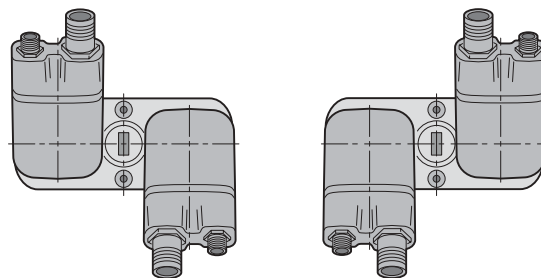

NOTE: The inlet (suction) ports of the pumps should always face the splitter box center, as shown, in order to counteract internal gear forces.

Fig. 1. F1-pumps installed on a splitter box.

Designation	SB 118	SB 154
Gear ratio (inp. shaft-to-pump)	1:1.18	1:1.54
Max input torque intermittent/continuous [Nm]	— 1000/700 —	
Max power	Housing oil temperature must not exceed 75 °C.	
Weight [kg]	— 11.5 —	
Ordering number	379 4981	370 5100

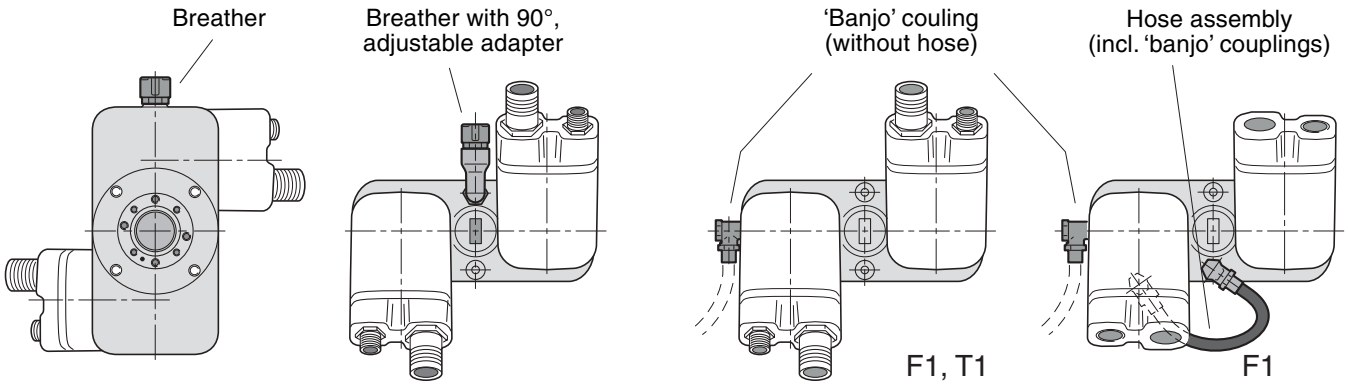

Breather kit (incl. 90°, adjustable adapter and seals):
 Part no. 378 1069.

Fig. 2. Breather installation on the splitter box.

Hose kit (hose sub-ass'y and separate 'banjo' coupling):
 Part no. 378 1085.

Fig. 3. Forced cooling of the splitter box.

Splitter box installation

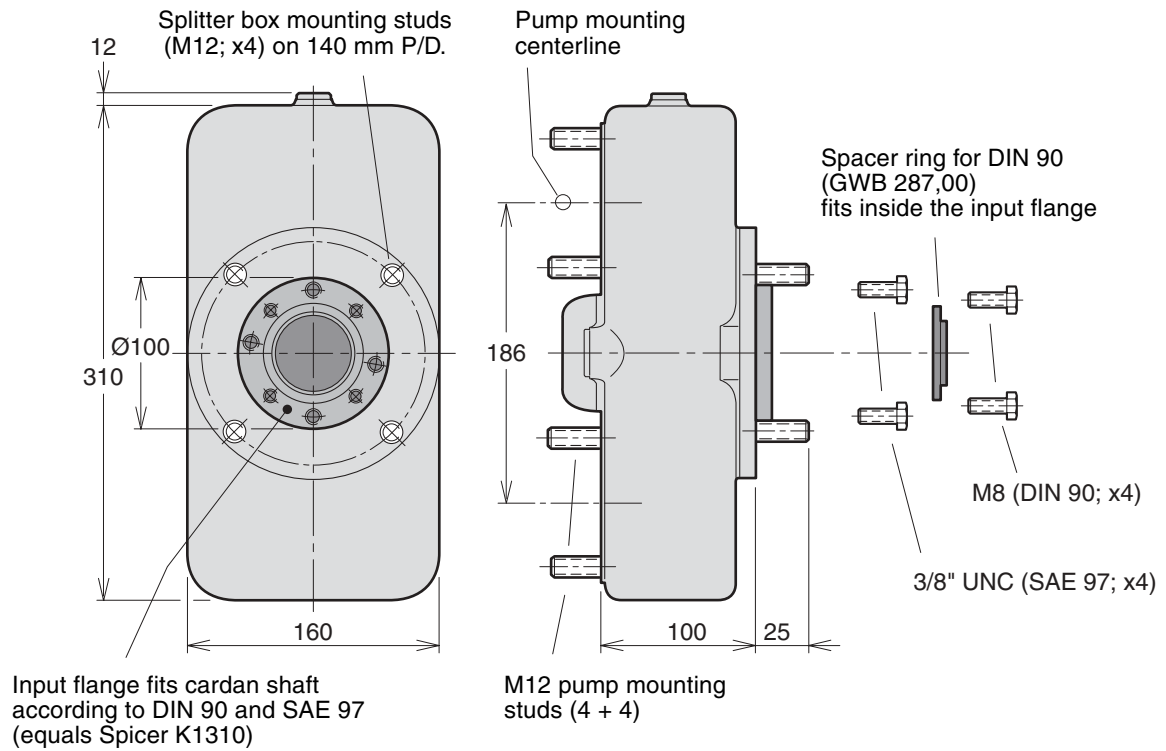

Installation and start up

Installing couplings, sleeves, and gears on the pump shaft.

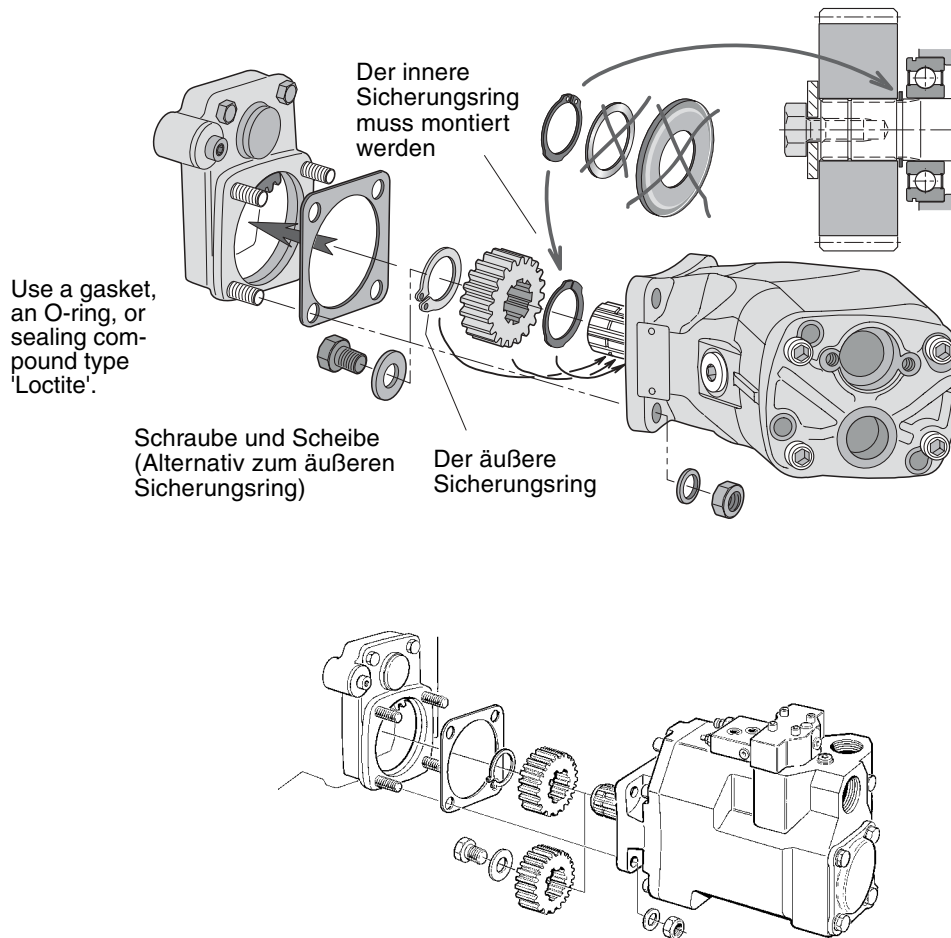

Fig. 6. VP1-to-PTO installation.

IMPORTANT

Our special tool (part no. 370 6851) facilitates installing couplings, sleeves, and gears on the pump shaft. Force must never be used when installing these parts on the F1 shaft.

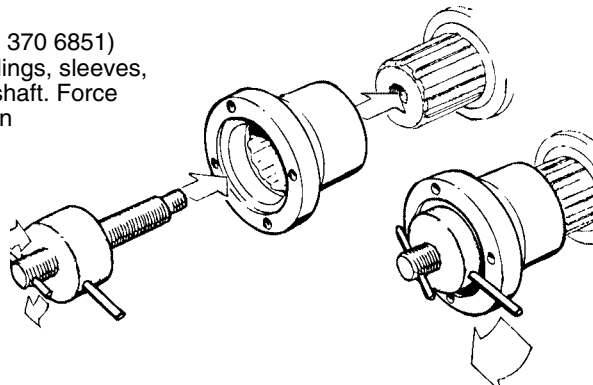
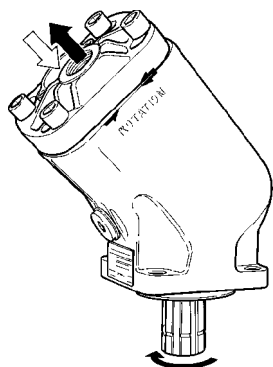

Fig. 7 Mounting tool.

NOTE: When considering installing an F1 on a splitter box, please refer to the installation information provided on pages 58- 59, chapter 11.

Installation and start-up for F1, F2 and T1



Left hand (L.H.; counter clockwise) rotating pump.

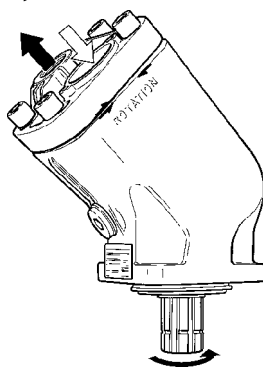

Right hand (R.H.; clockwise) rotating pump.

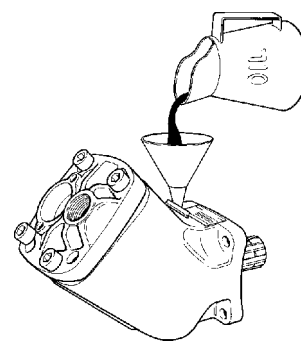

Before start-up, the housing must be filled with hydraulic fluid.

Direction of rotation

The pictures above show direction of flow vs. shaft rotation.

The direction of rotation can be changed (i. e. from right hand to left hand) by turning the end cap.

Remove the four cap screws and turn the end cap about half a turn while making sure it stays in contact with the barrel housing.

Re-fit the cap screws and torque to 80-100 Nm.

Installation

The robust shaft bearings allow the fixed displacement pumps to be mounted either on a bracket, driven by a belt or a cardan shaft, or directly on a PTO.

The top illustration on page 60 shows two ways of installing a gear on the shaft of fixed displacement pumps. The pump shaft spline end usually fits directly in the PTO internal spline coupling.

NOTE: In order to obtain the longest bearing life, the pump should be installed according to the information shown on page 62 "Pump bearing life".

Fluid viscosity

Recommended viscosity:
20 to 30 mm²/s (cSt).

Operating viscosity limits:

- Min 10 mm²/s; max 400 mm²/s.
- At start-up, max 4000 mm²/s.

Fluids

The fixed displacement pumps data shown in the specifications for each pump in chapter 3 to 6 are valid when operating on high quality, mineral based hydraulic oil. Type HLP (according to DIN 51524) hydraulic oil is suitable as well as biologically degradable fluids like natural and synthetic esters and polyalphaolefins.

The utilized hydraulic fluid shall meet one of the following Swedish standards:

- SS 15 54 34
 - SMR Hydraulic Oil Standard 1996-2.
- Contact Parker Hannifin (Mobile Controls Div.) for further information.

NOTE: - ATF (automatic transmission fluid) and API type CD engine oils may also be useable.

- Seals are made of nitrile rubber; make sure the utilized fluid is compatible with this material.

Fluid temperature

Main circuit: Max 75 °C.

Drain line

Fixed displacement pumps don't need an external drain line as they are internally drained.

Filtration

Filtration should follow ISO standard 4406, code 18/13.

To obtain the longest life of fixed displacement pumps, we recommend an oil cleanliness of 10 µm (absolute).

Start-up

Make sure the entire hydraulic system is clean before filling it with a recommended hydraulic fluid. In particular, make sure the pump is filled (to at least 50%) as the internal leakage does not provide sufficient lubrication at start-up.

NOTE: - The suction port should always be above the pressure port when the pump is installed above the reservoir oil level.

- During operation, the pump must be filled with oil to at least 50%.

NOTE: When considering installing an fixed displacement pump on a splitter box, please refer to the installation information provided on pages 58 and 59, chapter 11.

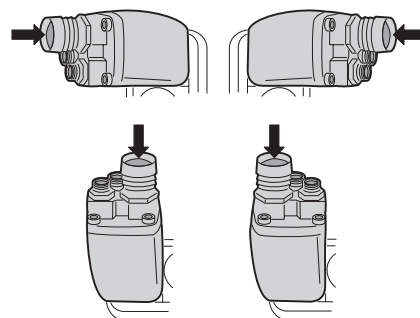

T1-to-PTO installation

- 'Left hand' and 'Right hand' rotation defined in the illustrations on page 61.

- The driving gear of the PTO and the driven gear of the pump are shown in the illustration below. (A right hand rotating pump is shown).

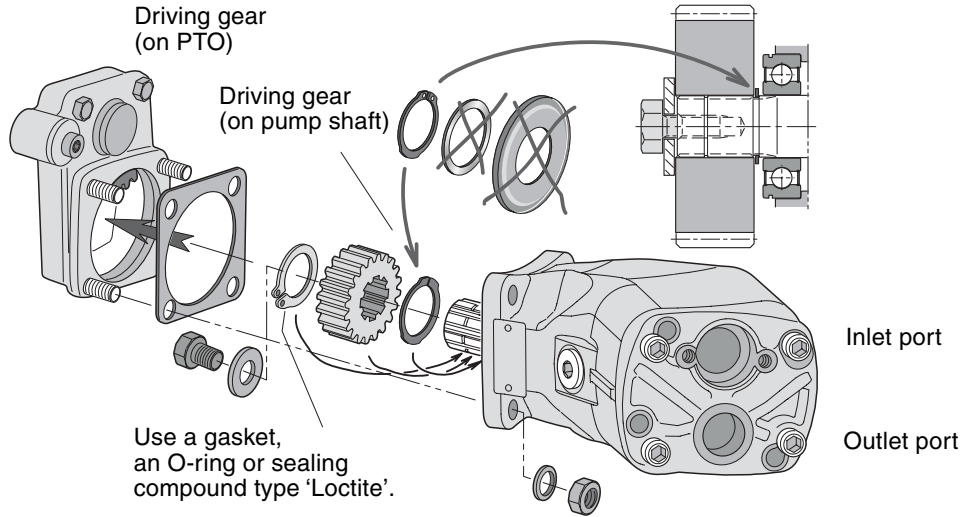

Pump bearing life

Bearing life is dependent on how the pump is installed on the PTO as shown in the illustrations below.

A pump mounted according to fig. 1 gives the lowest bearing life; the highest is obtained when installed according to fig. 3.

Parker Hannifin will assist in determining bearing life in a particular application.

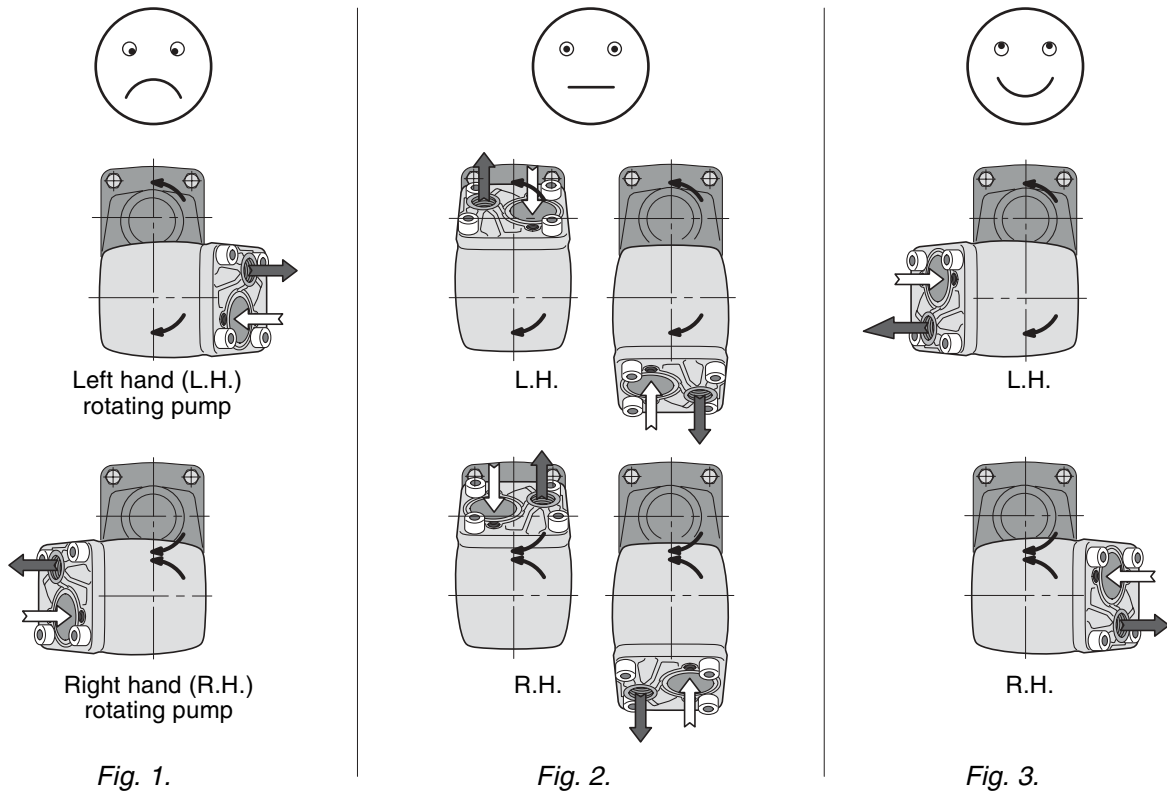

Installation and start-up for VP1

Direction of rotation

The basic VP1 pump is uni-directional; there is a left hand and a right hand version (indicated by the arrow on the side of the VP1 pump (fig. 4 and 5). Consequently, the required direction of rotation must be stated when ordering the pump.

Installation

The VP1 can be installed (close-coupled) directly on a PTO (which meets ISO DIN 5462). Before start-up, the pump must be filled with hydraulic fluid and purged. Utilize the uppermost purge plug (refer to the installation drawing on page 32, chapter 7). Figure 6 shows two ways of installing a gear on the VP1 shaft. On a non-geared or a geared PTO with support bearings, the pump shaft is usually installed directly in the internally splined PTO output shaft.

Hydraulic fluids

The VP1 data shown in the specifications on page 31, chapter 7 are valid when operating on a high quality, mineral based fluid. Hydraulic fluids type HLP (DIN 51524), ATF (automatic transmission fluids), and API type CD engine oils are suitable.

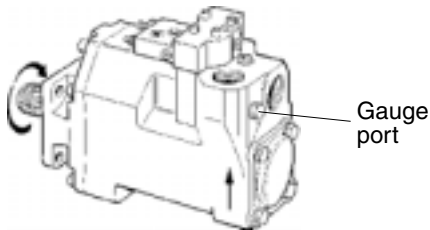

Fig. 4. Left hand rotating pump.

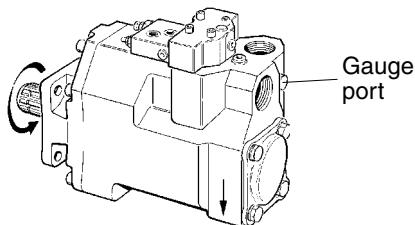

Fig. 5. Right hand rotating pump.

Fluid temperature

Main circuit: Max 75 °C.

Viscosity

Recommended viscosity: 20 to 30 mm²/s (cSt).
Operating viscosity limits: 10 - 400 mm²/s.
At start-up: Max 1000 mm²/s.

Filtration

To obtain long VP1 life, we recommend a filtration level of:

- 25 µm (absolute) in clean environment or at low pressures.
- 10 µm (absolute) in contaminated environment or at high pressures.

Filtration should meet ISO standard 4406, code 18/13.

Drain line

The LS valve *requires a separate drain line*; it should be routed directly to the reservoir (refer to fig. 8).

Start-up

Make sure the entire hydraulic system is clean before filling it with a recommended fluid. In addition, the VP1 pump must be purged to remove any entrapped air in the pump housing; utilize the uppermost purge port (fig. 8).

IMPORTANT

As shown in fig. 8, the pump inlet must always be below the lowest reservoir oil level.

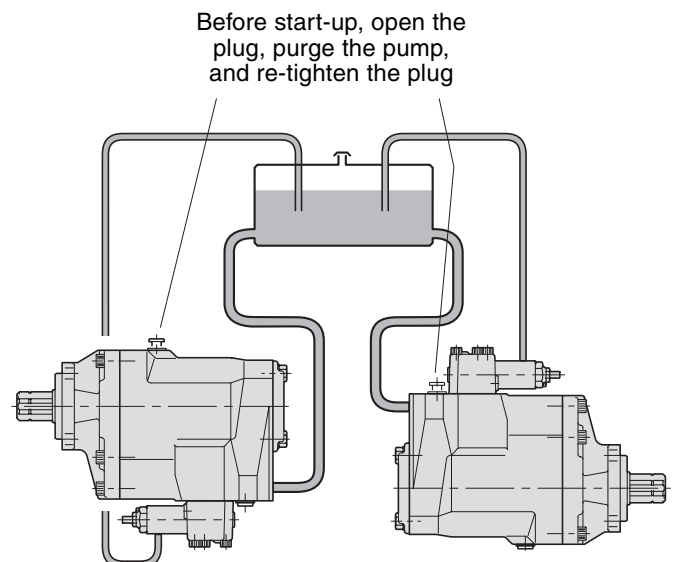

Fig. 8. VP1 should be installed below the reservoir fluid level.

Purging should be performed when the pump is connected to the reservoir and the system is filled with fluid.

Parker PTO's

Parker's power take-off units are designed to meet the requirement of the majority of today's truck applications. The PTO range covers a great many European trucks and is being continually updated to fit new gearboxes. The PTO's are used in a variety of applications such as Tippers, Hook Loaders, Skip Loaders and Cranes, and are specifically designed to close-couple pumps with the current ISO-Standard mounting flange. Alternatively, the units can be fitted with our cardan shaft adaptor to enable them to be used for a wide range of propshaft driven applications.

- Tailor made for the Parker Truck Hydraulics pumps Possibility to close-couple any ISO-standard pump
- Shaft-driven adaptor for other applications Competitively priced
- Easy to install
- Electrical indicator available on latest PTO's.

Parker can, with its range of PTO units, the F1, F2, T1 and VP1 truck pumps, and a great number of accessories, offer the total truck hydraulic package. Parker have in Europe become synonymous for extraordinary quality. Many body builders and chassis manufacturers now include our products as a standard part of their programme."

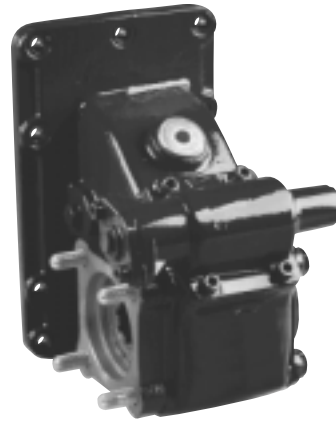

SCANIA



VOLVO



ZF

PTO's from Parker Chelsea

A comprehensive range

Parker Chelsea PTO's are designed to offer more output and shaft options than any other manufacturer, to ensure total compatibility no matter what the vehicle or application. A large percentage of the world's major OEM and transmission manufacturers and bodybuilders depend upon PTO's and auxiliary power products from Parker Chelsea for applications such as trucks, refuse vehicles, fire tenders, construction vehicles like backhoe loaders, excavators, tele handlers, etc. Close coupled pumps are another important accommodation where Chelsea outputs meet both SAE and DIN standards.

CHELSEA®



660 Series PTO

Heavy duty 6-bolt PTO to suit most popular transmission types. Intermittent torque rating up to 500 Nm.



880/885 Series PTO

Heavy duty 8-bolt PTO's available with air shift, hotshift and constant mesh options. Intermittent torque rating up to 678 Nm.



236 Series PTO

'Air/Hotshift' PTO for medium and heavy duty transmissions. Intermittent torque rating up to 406 Nm.



WARNING

FAILURE OR IMPROPER SELECTION OR IMPROPER USE OF THE PRODUCTS AND/OR SYSTEMS DESCRIBED HEREIN OR RELATED ITEMS CAN CAUSE DEATH, PERSONAL INJURY AND PROPERTY DAMAGE.

This document and other information from Parker Hannifin Corporation, its subsidiaries and authorized distributors provide product and/or system options for further investigation by users having technical expertise. It is important that you analyze all aspects of your application, including consequences of any failure, and review the information concerning the product or system in the current product catalogue. Due to the variety of operating conditions and applications for these products or systems, the user, through its own analysis and testing, is solely responsible for making the final selection of the products and systems and assuring that all performance, safety and warning requirements of the application are met.

The products described herein, including without limitation, product features, specifications, designs, availability and pricing, are subject to change by Parker Hannifin Corporation and its subsidiaries at any time without notice.

Offer of Sale

Please contact your Parker representation for a detailed "Offer of Sale".