



Vane Pump Series SDV

Fixed Displacement

Catalogue HY0738-A/CH

November 2004

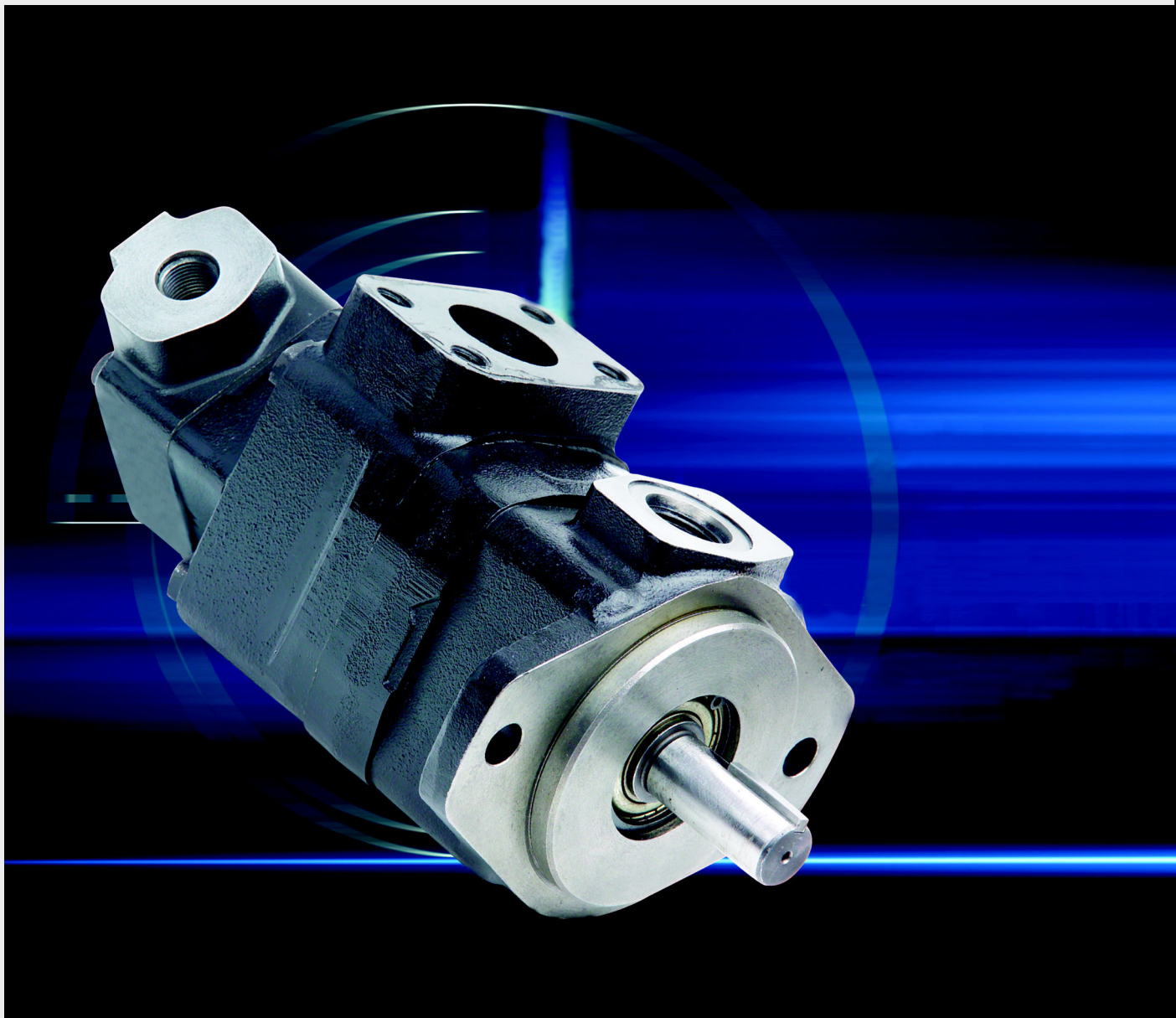

Minimum and maximum speed, pressure ratings

Series	Size	Theoretical Displacement Vi cm3/rev (in3/rev)	Maximum speed		Maximum pressure			
			HF-0, HF-1 HF-2	HF-3, HF-4 HF-5	HF-0, HF-2		HF-1, HF-4, HF-5	HF-3
			Int.	Cont.	Cont.	Cont.		
		RPM	RPM	Bar (psi)	Bar (psi)	Bar (psi)	Bar (psi)	
SDV10	1	3,3 (.20)	4200	1800	175 (2500)	160 (2250)	130 (1900)	100 (1500)
	2	6,6 (.40)	4200	1800	175 (2500)	160 (2250)	130 (1900)	100 (1500)
	3	9,8 (.60)	3900	1800	175 (2500)	160 (2250)	130 (1900)	100 (1500)
	4	13,1 (.80)	3000	1800	175 (2500)	160 (2250)	130 (1900)	100 (1500)
	5	16,4 (1.00)	2400	1800	175 (2500)	160 (2250)	130 (1900)	100 (1500)
	6	19,5 (1.19)	2100	1800	150 (2200)	140 (2000)	130 (1900)	100 (1500)
	7	22,8 (1.39)	1800	1800	140 (2000)	140 (2000)	130 (1900)	100 (1500)
SDV20	6	19,5 (1.19)	3600	1800	175 (2500)	160 (2250)	130 (1900)	110 (1600)
	7	22,8 (1.39)	2700	1800	175 (2500)	160 (2250)	130 (1900)	110 (1600)
	8	26,5 (1.62)	2400	1800	175 (2500)	160 (2250)	130 (1900)	110 (1600)
	9	29,7 (1.81)	2100	1800	175 (2500)	160 (2250)	130 (1900)	110 (1600)
	11	36,4 (2.22)	1800	1800	175 (2500)	160 (2250)	110 (1600)	100 (1400)
	12	39,0 (2.38)	1800	1800	150 (2200)	140 (2000)	110 (1600)	100 (1400)
	13	42,4 (2.59)	1800	1800	150 (2200)	140 (2000)	110 (1600)	100 (1400)

HF-0, HF-2 = Anti-wear petroleum base. HF-1 = Non anti-wear petroleum base. HF-5 = Synthetic fluids.

HF-3 = Water-in-oil invert emulsions. HF-4 = Water glycol solutions.

Minimum speed is 600 RPM

For further information, if the performance characteristics outlined above do not meet your own particular requirements, please consult your local Parker office.

Minimum allowable inlet pressure (bar absolute / psi)

Series	Ring size	Speed (RPM)										Size
		1500	1800	2100	2400	2700	3000	3300	3600	3900	4200	
SDV10	1	0,80 (11.6)	0,80 (11.6)	0,80 (11.6)	0,80 (11.6)	0,80 (11.6)	0,80 (11.6)	0,80 (11.6)	0,80 (11.6)	0,80 (11.6)	0,80 (11.6)	1
	2	0,80 (11.6)	0,80 (11.6)	0,80 (11.6)	0,80 (11.6)	0,80 (11.6)	0,80 (11.6)	0,80 (11.6)	0,80 (11.6)	0,80 (11.6)	0,80 (11.6)	2
	3	0,80 (11.6)	0,80 (11.6)	0,80 (11.6)	0,80 (11.6)	0,80 (11.6)	0,80 (11.6)	0,80 (11.6)	0,85 (12.3)	0,95 (13.8)		3
	4	0,80 (11.6)	0,80 (11.6)	0,80 (11.6)	0,80 (11.6)	0,85 (12.3)	0,95 (13.8)					4
	5	0,80 (11.6)	0,80 (11.6)	0,85 (12.3)	0,95 (13.8)							5
	6	0,80 (11.6)	0,85 (12.3)	1,00 (14.5)								6
	7	0,85 (12.3)	1,00 (14.5)									7
SDV20	6	0,80 (11.6)	0,80 (11.6)	0,80 (11.6)	0,80 (11.6)	0,80 (11.6)	0,85 (12.3)	0,95 (13.8)	1,01 (14.6)			6
	7	0,80 (11.6)	0,80 (11.6)	0,80 (11.6)	0,80 (11.6)	0,80 (11.6)						7
	8	0,80 (11.6)	0,80 (11.6)	0,85 (12.3)	0,95 (13.8)							8
	9	0,80 (11.6)	0,80 (11.6)	0,95 (13.8)								9
	11	0,80 (11.6)	0,95 (13.8)									11
	12	0,85 (12.3)	1,03 (14.9)									12
	13	0,95 (13.8)	1,05 (15.2)									13

Multiply absolute pressure by 1,25 for HF-3, HF-4 fluids.

by 1,35 for HF-5 fluids.

by 1,10 for ester or rapeseed base

Use the cartridge with the highest absolute pressure for double pumps.

General characteristics

Series	Mounting standard	Weight kg (lb)	Moment of inertia kgm ² x10 ⁻⁴ (lb.in ²)	Port connections					
				Suction			Pressure		
Code				P	S	B	P	S	B
SDV10	SAE A	4.5-6.8 (10 -15)	0.5 (0.17)	1" NPTF	1-5/16 12UNF-2B	G 1"	1/2" NPTF	3/4" 16UNF-2B	G 1/2"
SDV20	SAE A	7.3-8.2 (16-18)	2.2 (0.75)	1-1/4 NPTF	1-5/8 12UNF-2B	G 1-1/4	3/4" NPTF	1-1/16 12UNF-2B	G 3/4"
Code				F			S		
							P1*	P2**	P1-P2
SDV2010	SAE B	13.6 (30.0)	2.6 (0.90)	4 bolts flange 1-1/2" dia			1-1/16 12UNF-2B	3/4" 16UNF-2B	***
SDV2020	SAE B	15.9 (35.0)	4.3 (1.50)	4 bolts flange 2" dia			1-1/16 12UNF-2B	1-1/16 12UNF-2B	G 3/4"

* P1 = Pressure port near the shaft

** P2 = Pressure port near the cover end

*** P1 = G 3/4" P2 = G 1/2"



Vane Pump Series SDV

Fixed Displacement

Catalogue HY0738-A/CH

November 2004

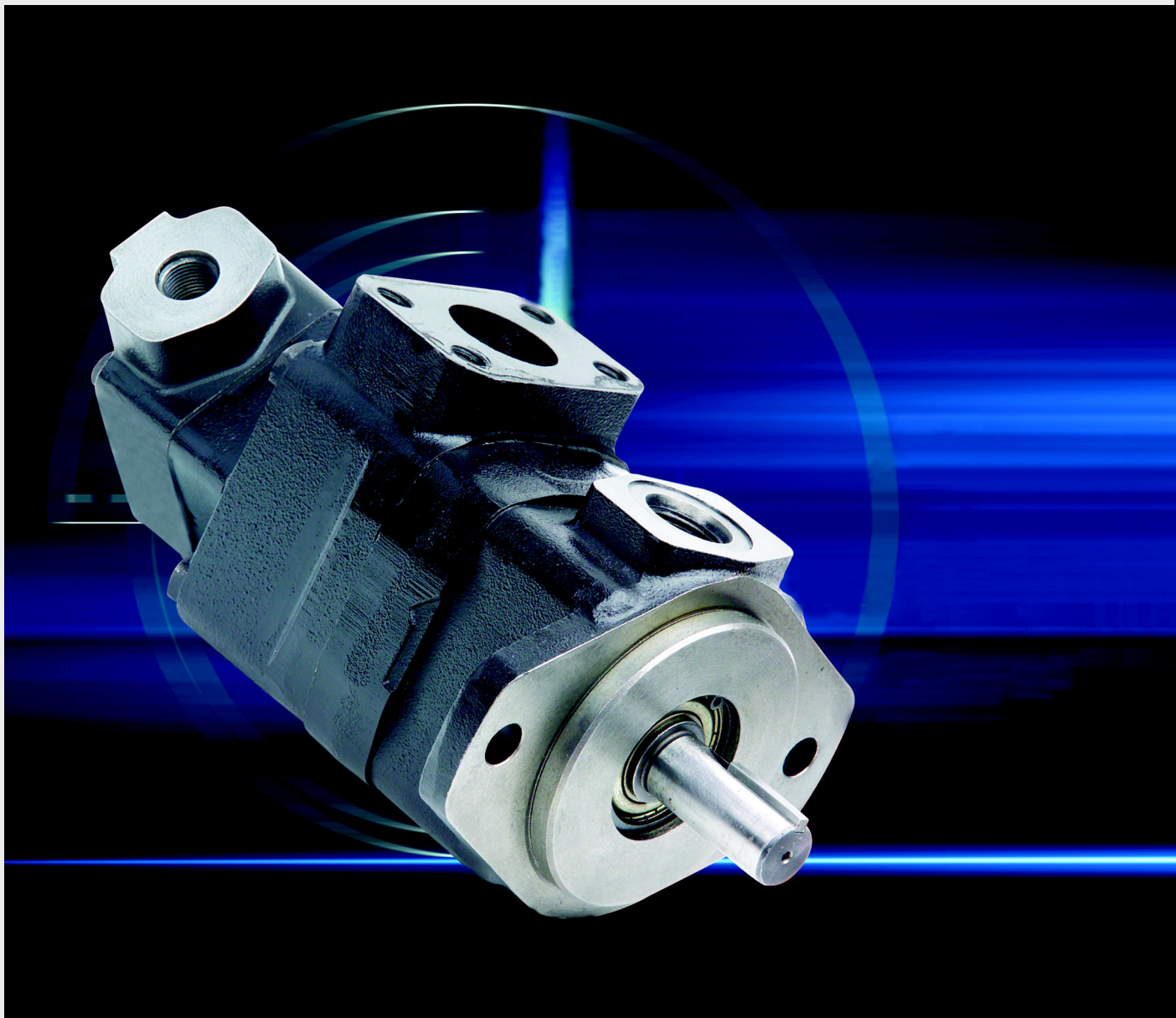

Minimum and maximum speed, pressure ratings

Series	Size	Theoretical Displacement Vi cm3/rev (in3/rev)	Maximum speed		Maximum pressure			
			HF-0, HF-1 HF-2	HF-3, HF-4 HF-5	HF-0, HF-2		HF-1, HF-4, HF-5	HF-3
			Int.	Cont.	Cont.	Cont.		
			RPM	RPM	Bar (psi)	Bar (psi)	Bar (psi)	Bar (psi)
SDV10	1	3,3 (.20)	4200	1800	175 (2500)	160 (2250)	130 (1900)	100 (1500)
	2	6,6 (.40)	4200	1800	175 (2500)	160 (2250)	130 (1900)	100 (1500)
	3	9,8 (.60)	3900	1800	175 (2500)	160 (2250)	130 (1900)	100 (1500)
	4	13,1 (.80)	3000	1800	175 (2500)	160 (2250)	130 (1900)	100 (1500)
	5	16,4 (1.00)	2400	1800	175 (2500)	160 (2250)	130 (1900)	100 (1500)
	6	19,5 (1.19)	2100	1800	150 (2200)	140 (2000)	130 (1900)	100 (1500)
	7	22,8 (1.39)	1800	1800	140 (2000)	140 (2000)	130 (1900)	100 (1500)
SDV20	6	19,5 (1.19)	3600	1800	175 (2500)	160 (2250)	130 (1900)	110 (1600)
	7	22,8 (1.39)	2700	1800	175 (2500)	160 (2250)	130 (1900)	110 (1600)
	8	26,5 (1.62)	2400	1800	175 (2500)	160 (2250)	130 (1900)	110 (1600)
	9	29,7 (1.81)	2100	1800	175 (2500)	160 (2250)	130 (1900)	110 (1600)
	11	36,4 (2.22)	1800	1800	175 (2500)	160 (2250)	110 (1600)	100 (1400)
	12	39,0 (2.38)	1800	1800	150 (2200)	140 (2000)	110 (1600)	100 (1400)
	13	42,4 (2.59)	1800	1800	150 (2200)	140 (2000)	110 (1600)	100 (1400)

HF-0, HF-2 = Anti-wear petroleum base. HF-1 = Non anti-wear petroleum base. HF-5 = Synthetic fluids.

HF-3 = Water-in-oil invert emulsions. HF-4 = Water glycol solutions.

Minimum speed is 600 RPM

For further information, if the performance characteristics outlined above do not meet your own particular requirements, please consult your local Parker office.

Minimum allowable inlet pressure (bar absolute / psi)

Series	Ring size	Speed (RPM)										Size
		1500	1800	2100	2400	2700	3000	3300	3600	3900	4200	
SDV10	1	0,80 (11.6)	0,80 (11.6)	0,80 (11.6)	0,80 (11.6)	0,80 (11.6)	0,80 (11.6)	0,80 (11.6)	0,80 (11.6)	0,80 (11.6)	0,80 (11.6)	1
	2	0,80 (11.6)	0,80 (11.6)	0,80 (11.6)	0,80 (11.6)	0,80 (11.6)	0,80 (11.6)	0,80 (11.6)	0,80 (11.6)	0,80 (11.6)	0,80 (11.6)	2
	3	0,80 (11.6)	0,80 (11.6)	0,80 (11.6)	0,80 (11.6)	0,80 (11.6)	0,80 (11.6)	0,80 (11.6)	0,85 (12.3)	0,95 (13.8)		3
	4	0,80 (11.6)	0,80 (11.6)	0,80 (11.6)	0,80 (11.6)	0,85 (12.3)	0,95 (13.8)					4
	5	0,80 (11.6)	0,80 (11.6)	0,85 (12.3)	0,95 (13.8)							5
	6	0,80 (11.6)	0,85 (12.3)	1,00 (14.5)								6
	7	0,85 (12.3)	1,00 (14.5)									7
SDV20	6	0,80 (11.6)	0,80 (11.6)	0,80 (11.6)	0,80 (11.6)	0,80 (11.6)	0,85 (12.3)	0,95 (13.8)	1,01 (14.6)			6
	7	0,80 (11.6)	0,80 (11.6)	0,80 (11.6)	0,80 (11.6)	0,80 (11.6)						7
	8	0,80 (11.6)	0,80 (11.6)	0,85 (12.3)	0,95 (13.8)							8
	9	0,80 (11.6)	0,80 (11.6)	0,95 (13.8)								9
	11	0,80 (11.6)	0,95 (13.8)									11
	12	0,85 (12.3)	1,03 (14.9)									12
	13	0,95 (13.8)	1,05 (15.2)									13

Multiply absolute pressure by 1,25 for HF-3, HF-4 fluids.

by 1,35 for HF-5 fluids.

by 1,10 for ester or rapeseed base

Use the cartridge with the highest absolute pressure for double pumps.

General characteristics

Series	Mounting standard	Weight kg (lb)	Moment of inertia kgm ² x10 ⁻⁴ (lb.in ²)	Port connections					
				Suction			Pressure		
Code				P	S	B	P	S	B
SDV10	SAE A	4.5-6.8 (10 -15)	0.5 (0.17)	1" NPTF	1-5/16 12UNF-2B	G 1"	1/2" NPTF	3/4" 16UNF-2B	G 1/2"
SDV20	SAE A	7.3-8.2 (16-18)	2.2 (0.75)	1-1/4 NPTF	1-5/8 12UNF-2B	G 1-1/4	3/4" NPTF	1-1/16 12UNF-2B	G 3/4"
Code				F			S		
							P1*	P2**	P1-P2
SDV2010	SAE B	13.6 (30.0)	2.6 (0.90)	4 bolts flange 1-1/2" dia			1-1/16 12UNF-2B	3/4" 16UNF-2B	***
SDV2020	SAE B	15.9 (35.0)	4.3 (1.50)	4 bolts flange 2" dia			1-1/16 12UNF-2B	1-1/16 12UNF-2B	G 3/4"

* P1 = Pressure port near the shaft

** P2 = Pressure port near the cover end

*** P1 = G 3/4" P2 = G 1/2"

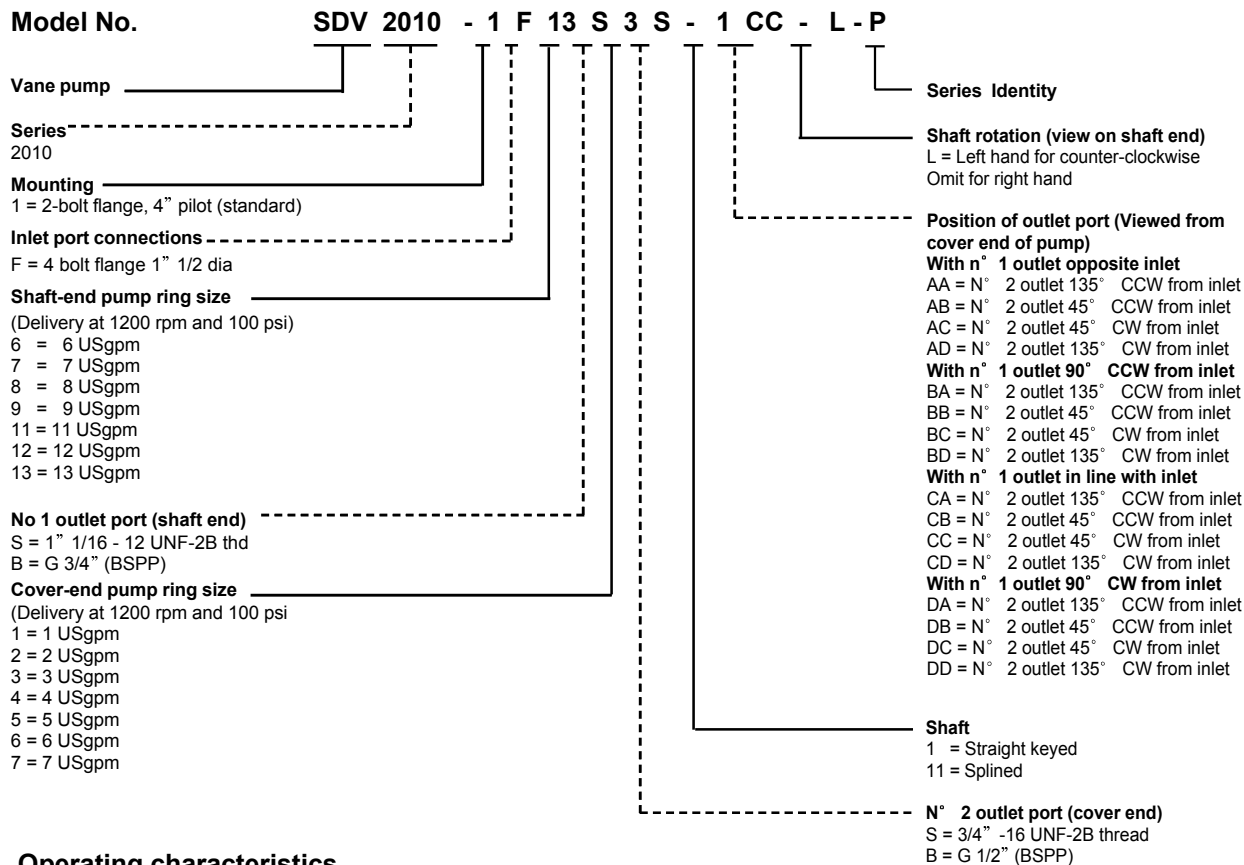

Operating characteristics

Model Series	Ring Size	Displ. cm ³ /rev (in ³ /rev)	Max. Pressure bar (psi)
P1	6	19,5 (1.19)	175 (2500)
	7	22,8 (1.39)	175 (2500)
	8	26,5 (1.62)	175 (2500)
	9	29,7 (1.81)	175 (2500)
	11	36,4 (2.22)	175 (2500)
	12	39,0 (2.38)	152 (2200)
	13	42,4 (2.59)	152 (2200)
P2	1	3,3 (.20)	175 (2500)
	2	6,6 (.40)	175 (2500)
	3	9,8 (.60)	175 (2500)
	4	13,1 (.80)	175 (2500)
	5	16,4 (1.00)	175 (2500)
	6	9,5 (1.19)	152 (2200)
	7	22,8 (1.39)	138 (2000)

Please refer to page 4

Please refer to page 6

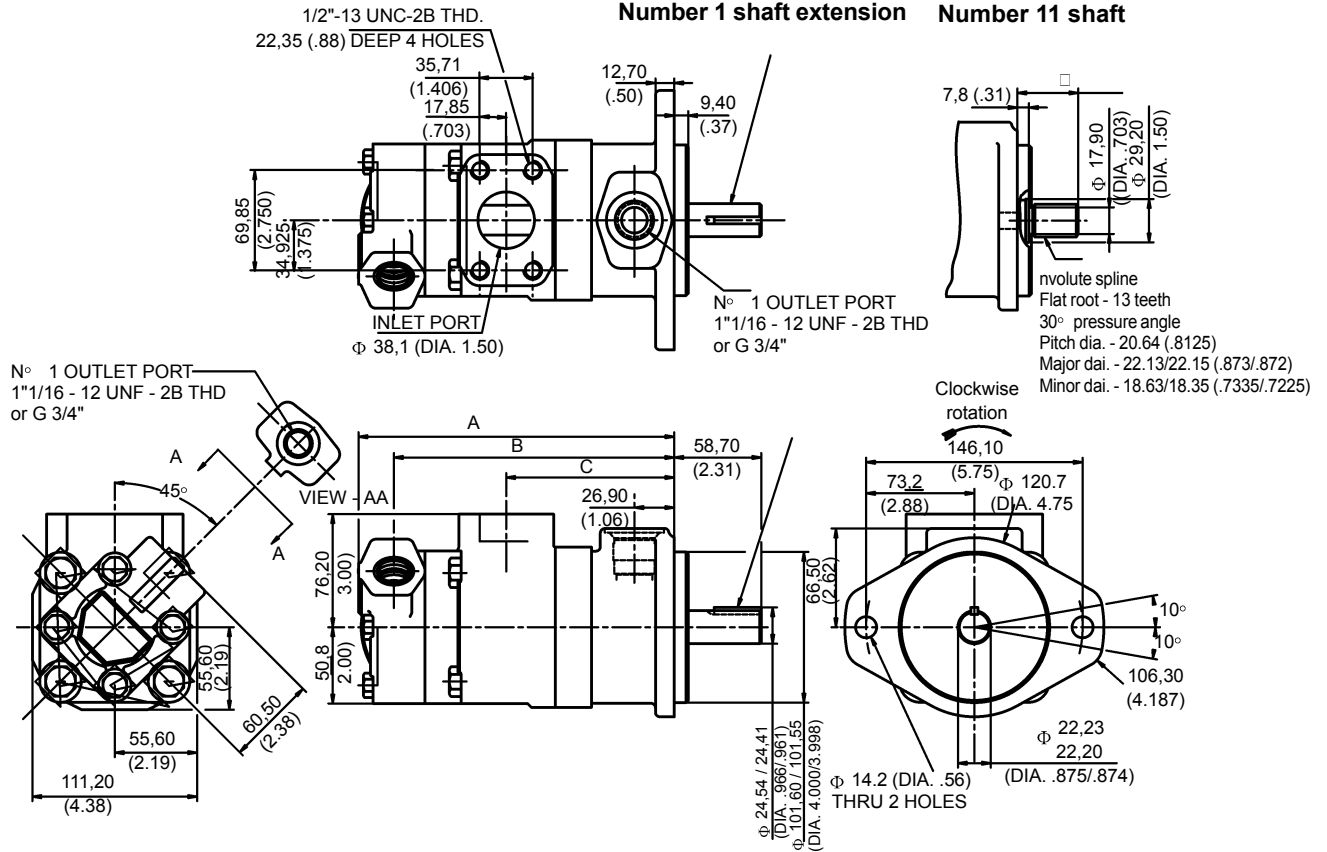

Ring size		Dimension			Ring size		Dimension			Weight Kg(lb)
Cover end	Shaft end	A	B	C	Cover end	Shaft end	A	B	C	
1, 2, 3,	6	207.2 (8.157)	183.5 (7.224)	107.1 (4.217)	4, 5	10, 11	225 (8.858)	201.3 (7.925)	118.5 (4.665)	13.6(30)
1, 2, 3,	7, 8, 9	213.6 (8.409)	189.9 (7.476)	113.5 (4.469)	4, 5	12, 13	228.5 (8.996)	204.8 (8.063)	122 (4.803)	
1, 2, 3,	10, 11	218.6 (8.606)	194.9 (7.673)	118.5 (4.665)	6, 7	6	218.6 (8.606)	194.9 (7.673)	107.1 (4.217)	
1, 2, 3,	12, 13	222.1 (8.744)	198.4 (7.811)	122 (4.803)	6, 7	7, 8, 9	225 (8.858)	201.3 (7.925)	113.5 (4.469)	
4, 5	6	213.6 (8.409)	189.9 (7.476)	107.1 (4.217)	6, 7	10, 11	230 (9.055)	206.3 (8.122)	118.5 (4.665)	
4, 5	7, 8, 9	220 (8.661)	196.3 (7.728)	113.5 (4.469)	6, 7	12, 13	233.5 (9.193)	209.8 (8.260)	122 (4.803)	

Internal leakage (typical)

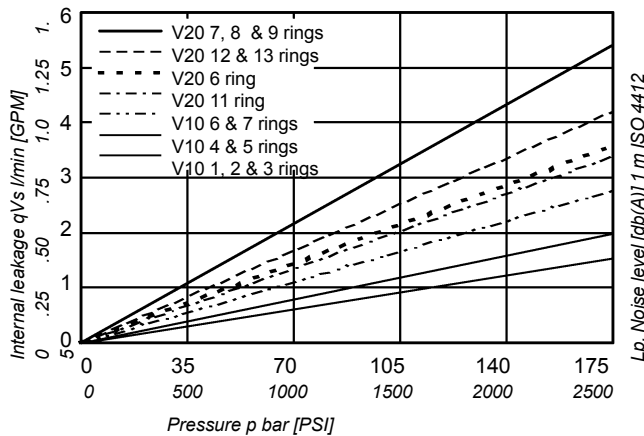

Do not operate pump more than 5 seconds at any speed or viscosity if internal leakage is higher than 50% of theoretical flow. Total leakage is the sum of each section loss at its operating conditions.

**Noise level (typical)
 SDV2010 - 13 - 6**

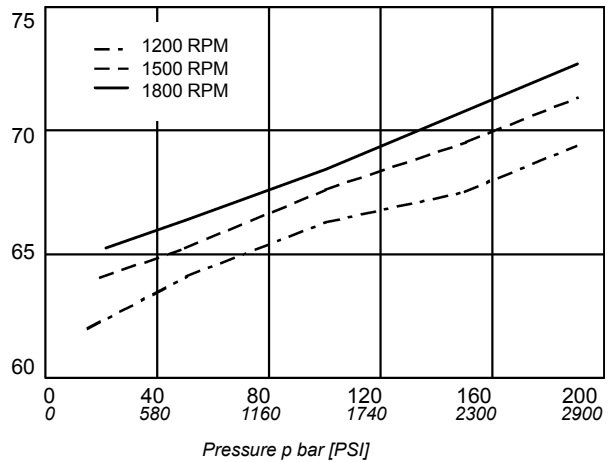

Double pump noise level is given with each section discharging at the pressure noted on the curve.