

# DENISON HYDRAULICS

## Pressure Relief Valves

Series R1E02



Publ. 3-EN 205-C, replaces 3-EN 205-B

**DENISON** Hydraulics

## FEATURES, SYMBOL, DESCRIPTION

### FEATURES

- These valves are available in four different mounting types:
  - cartridge type (manifold)
  - foot mounting
  - panel mounting
  - subplate mounting
- Stable pressure function due to the damping of the moving inner parts.
- Three different pressure setting ranges up to 350 bar.
- Three different control types are available:
  - hand knob
  - acorn nut with lead seal
  - adjusting device with key lock
- Usable as remote control valve for all pilot operated pressure control valves (e.g. DENISON series R4 and R5).
- Each valve is factory tested prior to delivery.
- Worldwide DENISON sales and service.

### SYMBOL

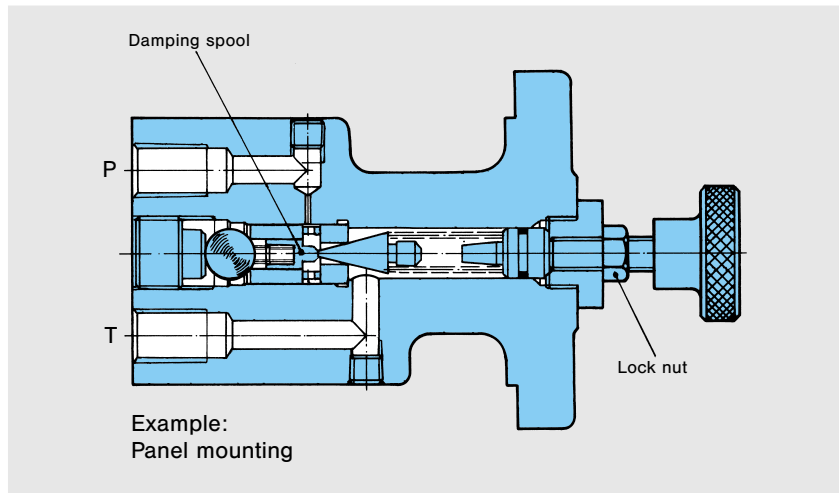
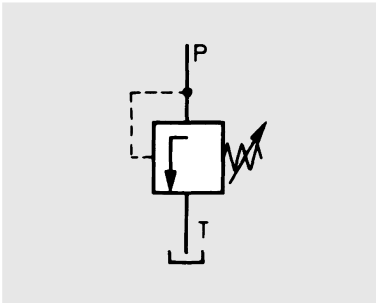

### DESCRIPTION

The DENISON valve series R1E02 is a direct operated pressure relief valve. It is designed to control system pressure according to the manual setting of the adjustment device (p-Q-function see diagram page 3). These reliable seat type valves consists mainly of seat, cone and pressure spring. Below the setting pressure the valve is leakage free. A damping spool maintains a stable function after the setting pressure is reached.

## TECHNICAL DATA, ORDERING CODE

### GENERAL

- |   |   |
|---|---|
| <ul style="list-style-type: none"> <li>• Design</li> <li>• Type of mounting</li> </ul>  | <ul style="list-style-type: none"> <li>Poppet type</li> <li>Subplate mounting</li> <li>Panel mounting</li> <li>Foot mounting</li> <li>Cartridge type (manifold) optional</li> </ul> |
| <ul style="list-style-type: none"> <li>• Mounting position</li> <li>• Direction of flow</li> <li>• Ambient temperature range</li> <li>• Suitability for special working conditions</li> </ul> | <ul style="list-style-type: none"> <li>P→T</li> <li>-20...+60 °C</li> <li>Further information required</li> </ul>   |

### HYDRAULIC CHARACTERISTICS

- |   |
|---|
| <ul style="list-style-type: none"> <li>• Operating pressure range                             <ul style="list-style-type: none"> <li>- Inlet (Port P) 0...350 bar</li> </ul> </li> <li>• Pressure setting range 7...350 bar</li> <li>• Nominal flow 3.8 l/min</li> <li>• Fluid Mineral oil according DIN 51524/25 (other fluids on request)</li> <li>• Contamination level Max. permissible contamination level according to NAS 1638 Class 8 (Class 9 for 15 micron and smaller) or ISO 17/14</li> <li>• Fluid temperature range -18...+80 °C</li> <li>• Viscosity range 10...650 cSt; optimal 30 cSt</li> </ul> |
|---|

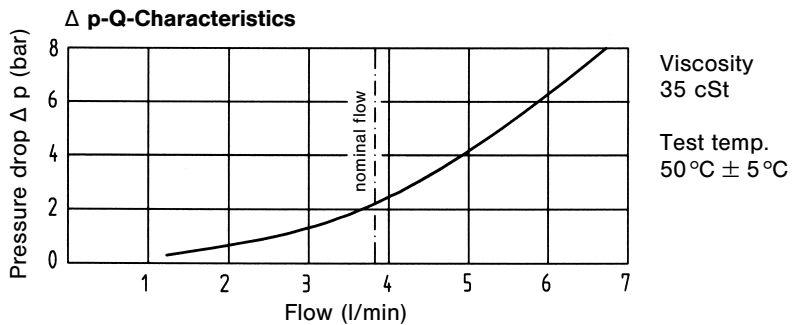

### ORDERING CODE

<p><b>Series</b> _____</p> <p><b>Body mounting</b> _____</p> <p>0 = Cartridge 1 = Foot mounting 2 = Panel mounting 3 = Subplate mounting</p> <p><b>Pressure setting range</b> _____</p> <p>1 = 7...105 bar 3 = 7...210 bar 5 = 7...350 bar</p> <p><b>Connections</b> _____</p> <p>0 = without (only for cartridge) 1 = 1/4" NPTF 2 = G 1/4"</p>	<p style="text-align: center;"><b>R1E02 - - - A - 1 -</b></p> <p style="text-align: right;"><b>Modification</b></p> <p style="text-align: right;"><b>Seal class</b> 1 = Standard (for special fluids consult DENISON)</p> <p style="text-align: right;"><b>Design letter</b></p> <p style="text-align: right;"><b>Type of control</b> 1 = Hand knob 32 mm dia. 2* = Hand knob 50 mm dia. 3 = Acorn nut with lead seal 4* = Adjusting device with key lock (key order no. 700-70619)</p>
---	---

\* = on bodies for subplate mounting use adapter plate S16-64188 if necessary.

The following 4 valve mounting screws are necessary then: M10 x 55

DIN 912; 12.9

Order no. 700-71447-8

## DIMENSIONS

### Panel mounting

2.1 kg

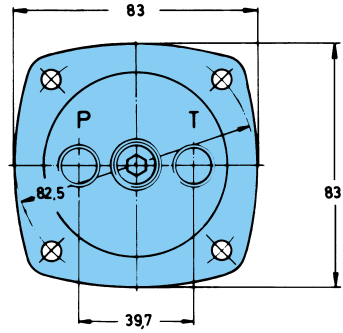
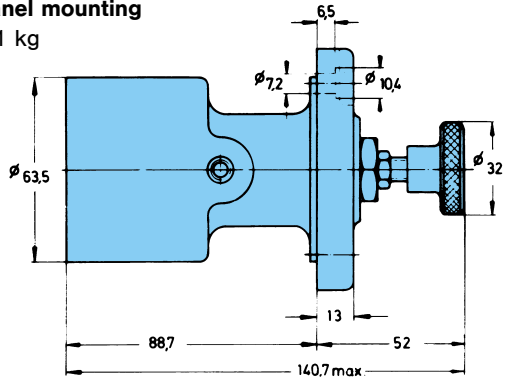

Ports P and T: 1/4" NPTF or G 1/4"

### Foot mounting

2.1 kg

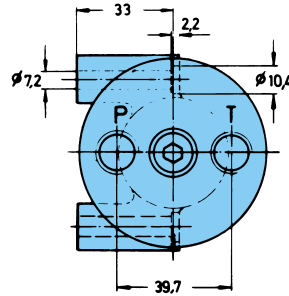
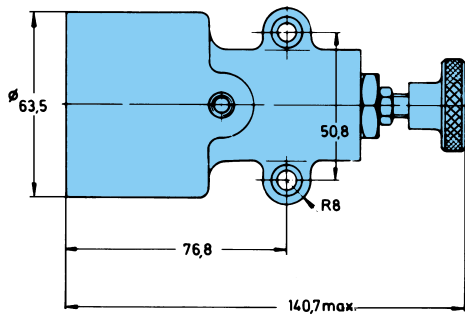

### Subplate mounting

1 kg

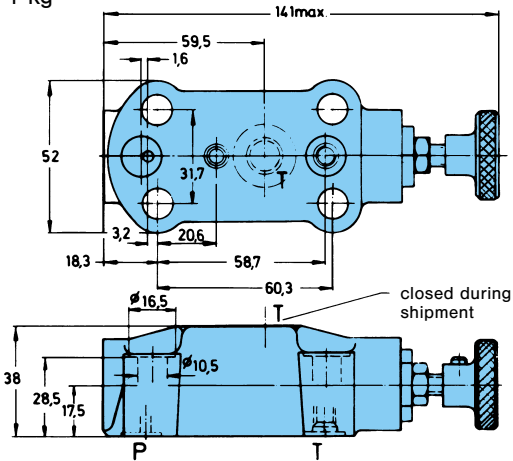

### Optional adjusting devices

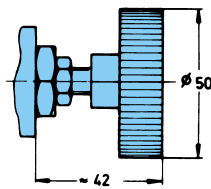

Hand knob  
50 mm dia.

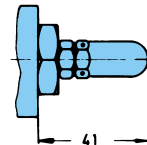

Acorn nut  
with lead seal

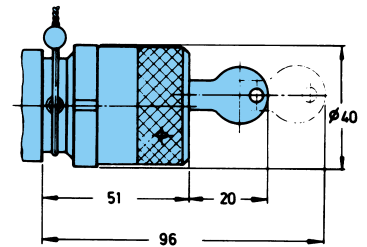

Adjusting device  
with key lock

### Cartridge type

0.3 kg

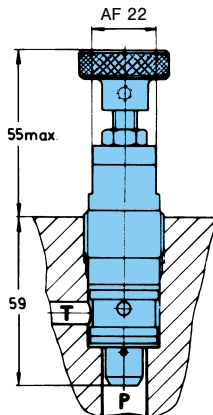

### Installation dimensions

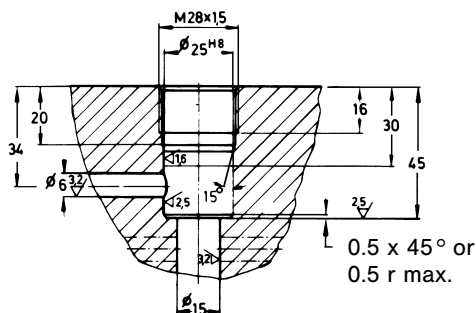

## SUBPLATES

Weight: 1.4 kg

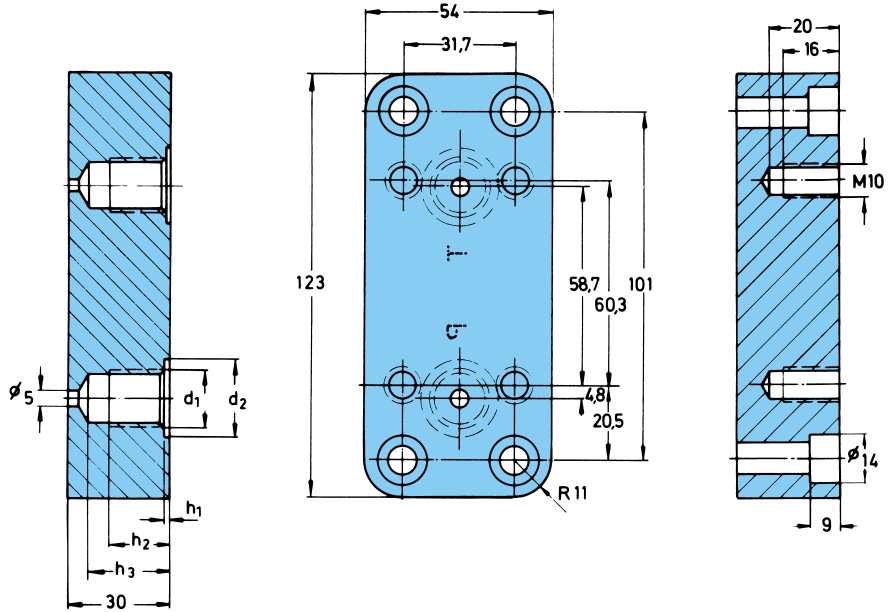

Model no.	Order no.	Port d <sub>1</sub>	Dimensions				4 Mounting screws *	
			h <sub>1</sub>	h <sub>2</sub>	h <sub>3</sub>	d <sub>2</sub>	Dimension	Order no.
SS-B-04-04	S16-33062-0	G 1/4"	0.5	14.0	19.0	24.0	M10 x 40 lg. DIN 912; 12.9	700-71595-8
SS-B-06-04	S16-33064-0	G 3/8"	0.5	14.0	19.0	24.0		

\* Mounting screws are included in subplate order.

For valves ordered without subplate, mounting screws must be ordered separately.

The product described is subject to continual development and the manufacturer reserves the right to change the specifications without notice.