

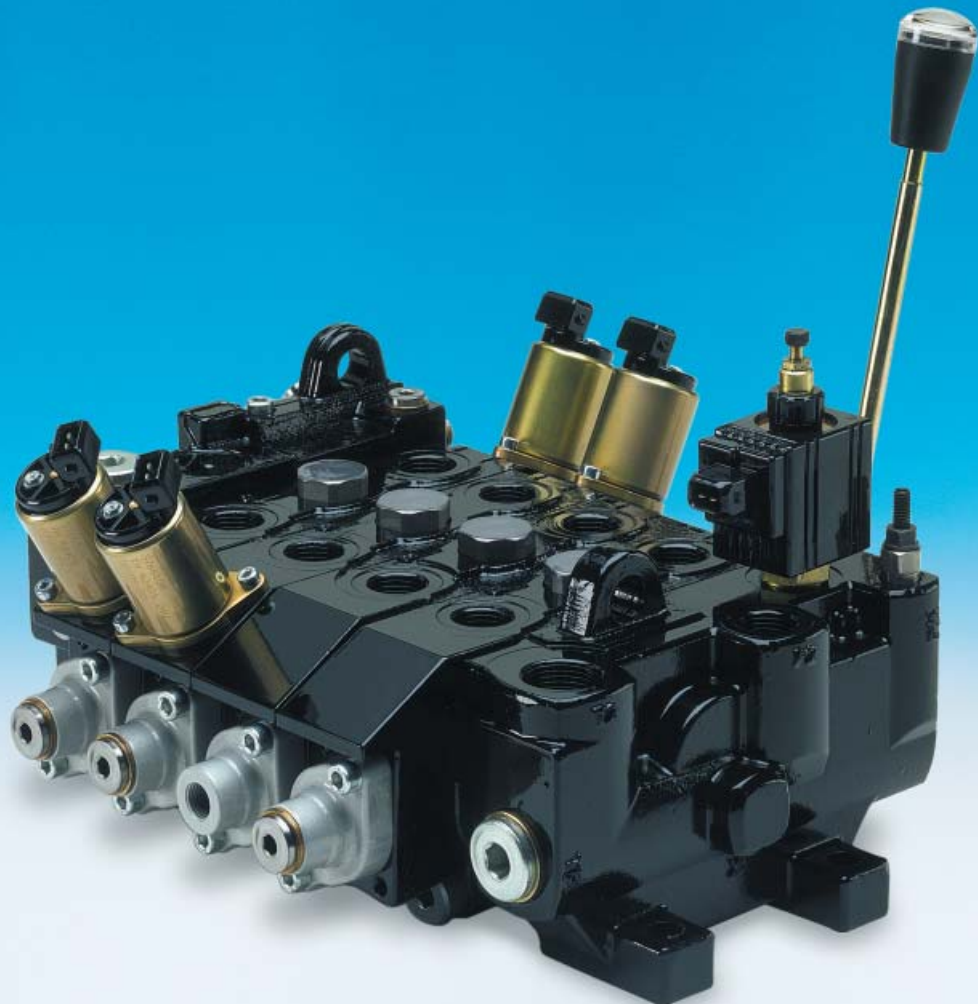

Directional Control Valve - P70

*Open or Closed Centre
Proportional Valve Series*

*Catalogue HY17-8546/UK
December, 2004*



Catalogue layout

This catalogue is designed to give an overview of the P70CF directional valve and to show how it can be customised to meet your needs exactly. Apart from general information and basic technical data therefore, the catalogue contains descriptions of the variety of options available for the different function areas of the valve. After you have studied the options and made your selection, we will tailor your valve to meet your operating and control criteria.

Each function area is given as a subheading, followed by a brief description. When several optional functions are available for the same function area, the subheading is followed by an "Item number" in square brackets, e.g. **Main pressure relief valve [16]**. This is followed by a series of coded options, e.g. **PS**,

PB, Y, together with a brief description of what each code represents. Alternatively, one or more pressure, flow or voltage options are given.

On pages 10 and 11 are general circuit diagrams showing the basic functions of the P70CF valve, together with the item numbers and letter codes used to represent them. Naturally, the same item numbers and letter codes are used in all sub-circuit diagrams that appear elsewhere in the catalogue in conjunction with descriptions of the respective function areas. All sub-circuit diagrams have been extracted from the general circuit diagram. Please note that, unless stated otherwise, all sections and views of the valves have been drawn as seen from the inlet section.

How to order your valve

Parker has developed a computer program to specify the P70CF, so that the configuration of your valve can be optimised to give maximum performance in your particular hydraulic system.

Based on the demands on each individual machine function, the computer specifies the configuration of the valve to give optimal performance. It also generates complete documentation for

your valve in the form of a detailed specification and hydraulic circuit diagram.

The program also generates a unique product ID number that is subsequently stamped into the data plate on your valve. Your customised valve specifications remain on our database to facilitate rapid identification of your valve in the event of re-ordering or servicing.

Early consultation with Parker saves time and money

Our experienced application engineers have in-depth knowledge of the different types of hydraulic system and the ways in which they work. They are at your disposal to offer qualified advice on the various combinations of functions and control characteristics you may require, and to advise how to obtain the best possible economy.

By consulting Parker early in the project planning stage, you are assured of a comprehensive hydraulic system that will give your machine the best possible operating and control characteristics, together with outstanding economy.

Subject to alteration without prior notice. The graphs and diagrams in this catalogue are typical examples only. While the contents of the catalogue are updated continually, the validity of the information given should always be confirmed. For more detailed information, please contact Parker Hannifin.

Conversion factors

1 kg	= 2.2046 lb
1 N	= 0.22481 lbf
1 bar	= 14.504 psi
1 l	= 0.21997 UK gallon
1 l	= 0.26417 US gallon
1 cm ³	= 0.061024 in ³
1 m	= 3.2808 feet
1 mm	= 0.03937 in
9/5 °C + 32	= °F

List of contents	Page
General Information	4
Constant-flow systems (CFO) (Valve with open centre, P70CF)	5
Control characteristics	5
Constant-pressure systems, CP, CPU (Valve with closed centre, P70CP)	6
Control characteristics	6
System connection	7
A. Series connection, multi-valve system, P70CF only	7
B. Series connection, single-valve system, P70CF only	7
C. Parallel connection, multi-valve system	7
Technical Data	8
Environmental characteristics	9
Hydraulic circuit diagram showing basic functions, standard valve	10
Hydraulic circuit diagram showing basic functions (model with integral spool actuators)	11
Inlet Section	12
Type of inlet section [15]	12
Main pressure relief valve [16]	14
Pressure setting [17]	14
Pump unloading [22]	14
External pump unloading or multi-level main pressure relief function	15
Tank connection T2 [25]	15
Pump connection P1 [26]	15
Pump connection P2 [27]	15
Mid-inlet section [90]	16
Options, mid-inlet [93]	17
Main pressure relief valve [94]	17
Pressure setting [98]	17
End Section	18
Type of end section [30]	18
Tank connection T1 [33]	18
Tank connection T3 [34]	18
Series-connection function [36]	18
Pump connection P3 [35]	18
Reducing valve [37]	19
Pilot-oil strainer [39]	19
Separate tank connection for pilot circuit [40]	19
Spool Sections	20
Type of spool section [47]	20
Lever bracket [51]	21
Spool actuators [50]	21
Hand-operated spool actuators with open spool end	21
Remote controlled ON/OFF spool actuators with open spool end	21
Remote controlled proportional spool actuators with closed spool end ...	22-24
Choice of Spool	25
Spool function [60]	25
Spool designation [69]	25
Pressure gallery [66]	25
Pressure limiters in service ports [76A/B]	26
Port relief valve [76]	26
Function blocks (manifolds)	27
Electrical connectors	27
Hand levers for open spool-actuators	27
Hand levers for closed spool-actuators	27
Dimensional drawings, standard valve	28
Dimensional drawings, model with integral spool actuators	29
Dimensional drawings, spool actuators	30

[00] refers to item numbers in customer specification.

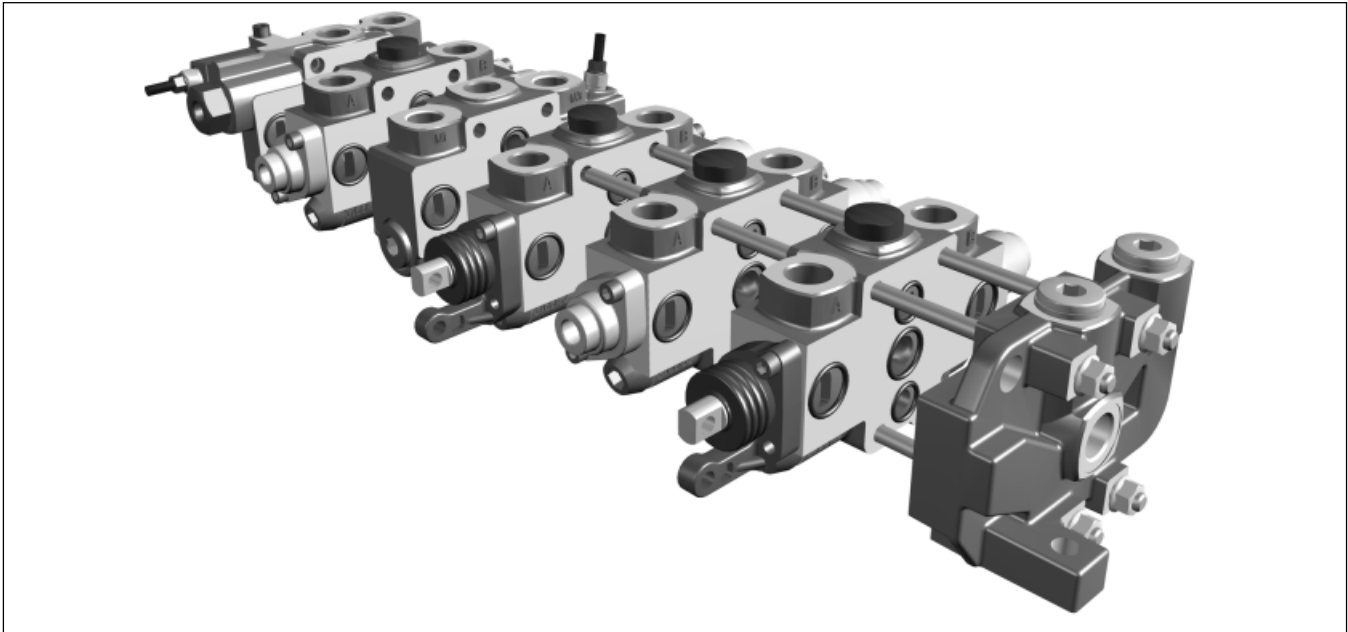

The P70 directional valve is of modular construction. It is designed for many different applications and used extensively in machines such as lorry cranes, mini-excavators, small wheeled loaders and concrete placing cranes. The P70 is available in two different versions: the **P70CF** with open centre for use with fixed pumps and the **P70CP** with closed centre for use with variable pumps.

Compact system construction

The P70CF is of modular construction and offers unique possibilities for the integration of application-adapted functions to give compact and total system solutions for a wide range of mobile machines.

Freedom in machine design

The valve can be of the directly operated type, or can be equipped for electric, pneumatic or hydraulic remote control. A combination of direct and remote control is also possible. These options give the designer great freedom in terms of component location and the choice of pilot media.

Economy

Thanks to its modular construction, the P70 can be optimised for both simple and complex functions. The possibility of integrating total function solutions gives low overall system costs. The valve can be modified or expanded as necessary to suit the needs of the customer.

Safety

The valve is of robust construction, with each function unitised. This facilitates

both training and servicing and contributes greatly to safety. Moreover, the valve can be fitted with a special inlet section that enables an emergency STOP function to be incorporated into the valve to meet the demands of the EC Machinery Directive in a uniquely simple way.

Design

The P70 is stackable and can be supplied in combinations of 1 to 10 spool sections, and also in combination with function manifolds. The valve is designed for system pressures up to 320 bar (see diagram, page 14) and can be equipped with port relief valves in the service ports for pressures up to 350 bar. The maximum recommended flow rate is 70 l/min for the P70CF, depending on how the valve is equipped, and 90 l/min for the P70CP. There is a wide range of spools for the valve, which enables its control characteristics to be optimised.

Essential characteristics

- Low lever forces give comfortable operation when the valve is controlled directly.
- Flexible, modular construction makes it easy to modify or expand the P70CF to meet changing needs.
- Easy to change spools at any time, thanks to good manufacturing precision.
- Can be flanged to both standard and specially customised function manifolds. This enables even more functions to be integrated into a single unit in a compact system, with minimal piping.

- Mid-inlet sections enable compact system construction, even in systems with several pressure levels.
- Can be equipped for both multi-pump and multi-valve systems, thus increasing its range of applications in many different types of hydraulic system.
- Very wide range of application-adapted spools designed to optimise control characteristics.
- Our proportional remote-controlled valves have pressure compensated spools, which further improves control and simultaneous-operating characteristics.
- Separate check valve in each spool section prevents undesirable sinking of the load.
- Separate port-relief valve in each service port gives individual maximum pressure limitation.
- Low pressure drops keep down energy losses and reduce the generation of heat.
- Machined land edges in the valve housing guarantee good control characteristics.
- Quality materials and high manufacturing precision ensure a superior product with low internal leakage and long service life.
- A wide range of optional functions enables the P70CF to be customised to meet your needs precisely.
- Open spool ends with rubber bellows increase the service life of both spools and spool seals.
- An emphasis on simplicity of design makes the P70CF easy to service.

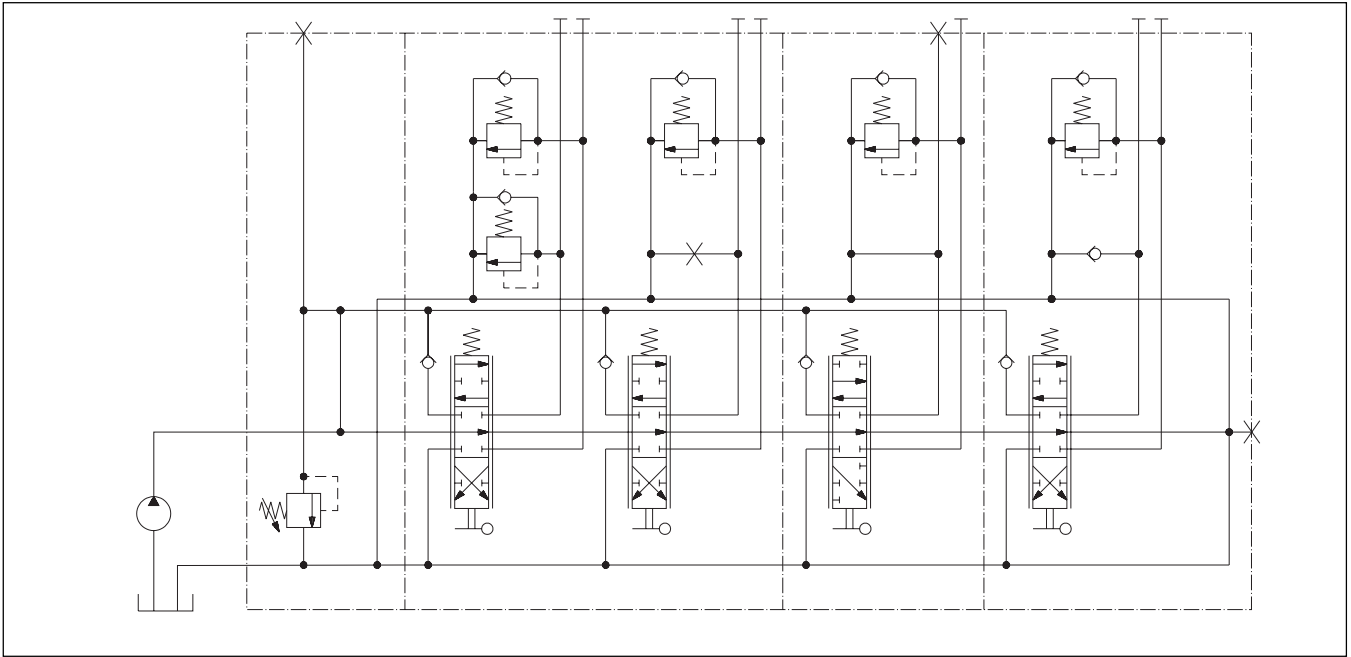

Basic circuit diagram, CFO

Constant-flow systems (CFO)
(Valve with open centre, P70CF)

The pump in a constant-flow system has fixed displacement, which means that the flow remains constant for a given engine speed. The pressure, however, changes to meet demand.

Any oil that is not directed out to a consumer flows back to tank via the free-flow gallery (open centre) in the valve. When several lifting functions are activated simultaneously, the pressure is determined by the heaviest load. Simultaneously operated functions should therefore have roughly the same pressure needs, or be divided into separate pump circuits to minimise cross-functional interference and give good operating economy. Provided that most of the pump capacity is used, the CFO system is very economical. For this reason, it is important for the system to have a pump of the right capacity.

Control characteristics

In hand-operated valves, there is no clear-cut relationship between the stroke of the lever and the speed of the load. The speed of the load will depend on its weight, the direction of force and direction of movement, by other simultaneously operated loads and by the pump flow. The reason for this is that, when more passages are opened subsequently, the flows redistribute themselves so that the pressure drop in all flow paths becomes equal.

The P70CF's customised valve spools give considerably better simultaneous-operating characteristics. In some cases, this can result in higher energy losses during the fine-metering stage.

Our directional valves intended for remote control usually have pressure compensated spools, which means that the regulated flow rate remains constant for a given lever stroke, regardless of pressure variations.

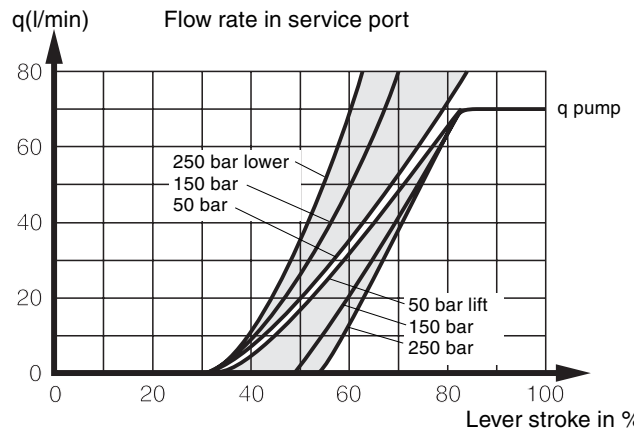

In P70CF valves with hand-operated spools, speed is affected by the weight of the load, i.e. the heavier the lift load, the longer the lever stroke needed before the load starts to move. Conversely, the heavier the load to be lowered, the faster the lowering sequence.

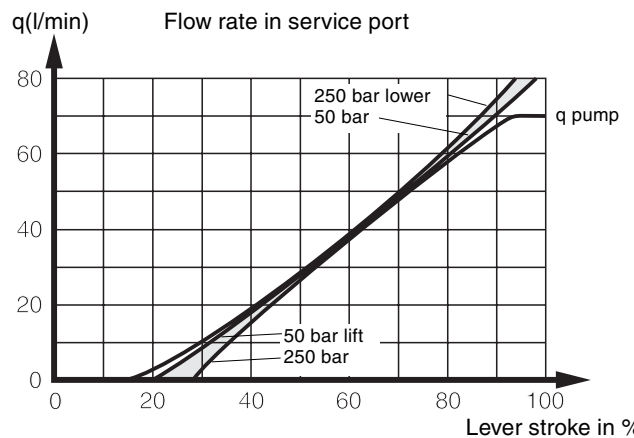

In the P70CF equipped with FPC, PC, PCI, EC and ECH closed spool-actuators, the spools are pressure compensated, with the result that the load's influence on speed is negligible.

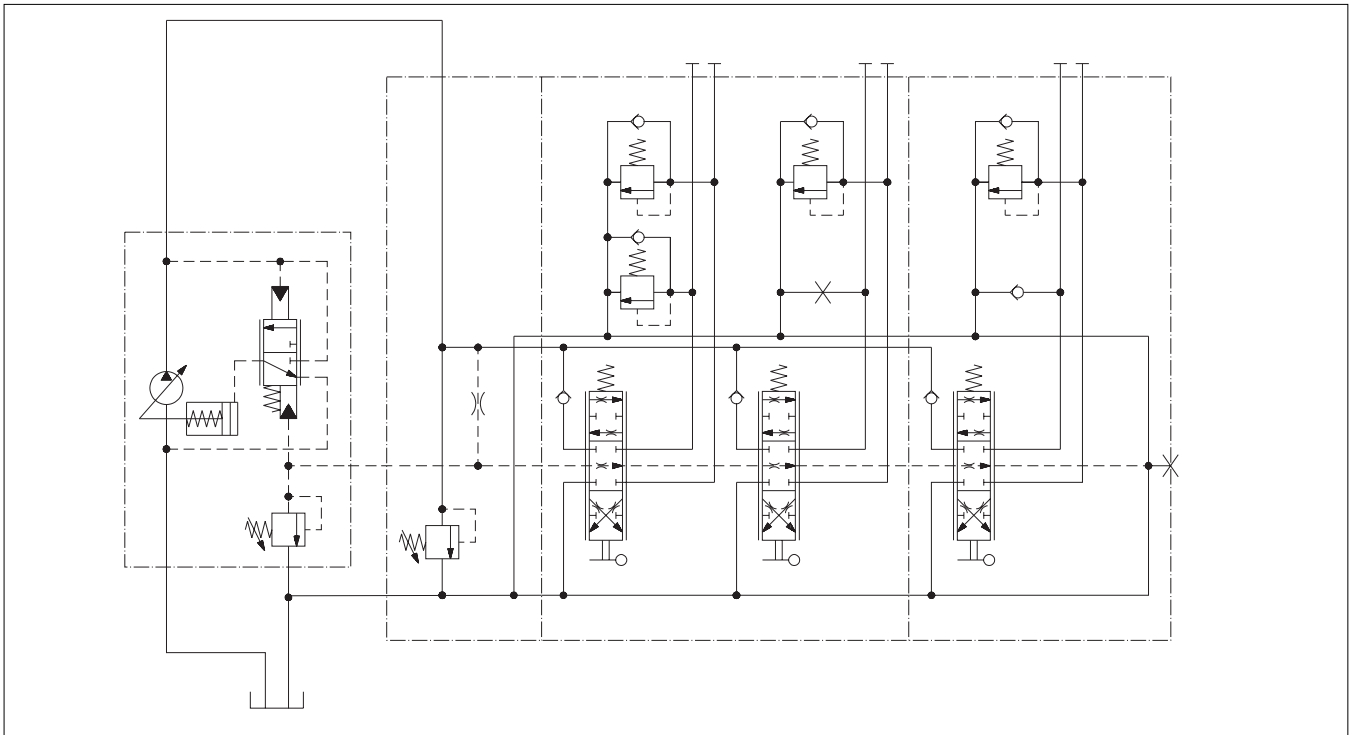

Principle circuit diagram for valve with closed centre

Constant-pressure systems, CP, CPU
(Valve with closed centre, P70CP)

The pump in a constant-pressure system has variable displacement controlled by a regulator, so that the pressure is kept constant while flow is varied to suit demand. The constant-pressure system is of relatively simple construction, with an uncomplicated valve. However, the variable pump is more advanced than pumps with fixed displacement.

To maintain the constant-pressure system's superior control characteristics, the pump must be dimensioned to give the sum of the maximum flows for simultaneously operated functions. If the pressure cannot be maintained, the valve loses its control characteristics quickly and the actuated functions start to influence each other, with the lightest loads receiving the most oil. The system is less sensitive to pressure drops, since a pressure corresponding to the capacity limit of the machine is always available.

There are mainly two types of pump on the market. What distinguishes them from each other is where the signal that influences the pump regulator comes from. One pump type takes the signal internally, whereas the other requires a signal from the directional valve. The P70CP can be used equally efficiently with either type.

Control characteristics

With a correctly customised P70CP valve, the system is given very good control characteristics and different functions do not affect each other. The system has good anti-cavitation characteristics, which means that a lowering movement can be changed to a lifting movement without delay. The maximum speed of each function is determined by the design of the spool and by the pressure demands of the load. In the P70CP too, remote controlled spools are pressure compensated. However, if the flow requirements of the system exceed the maximum capacity of the pump, the pressure level cannot be maintained and the normally very good control characteristics deteriorate.

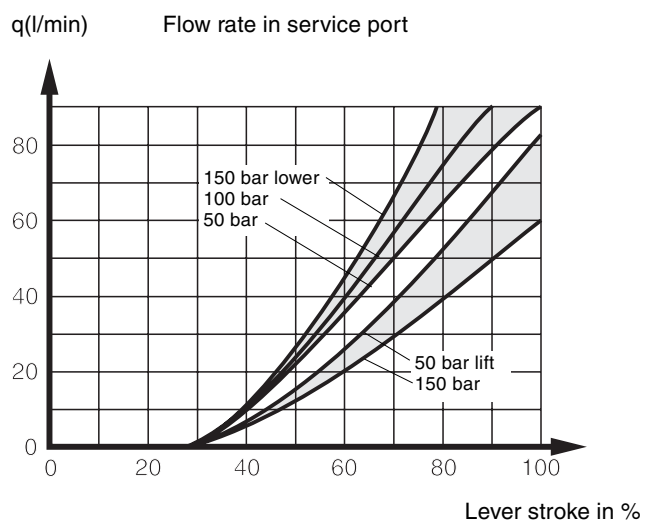

In the P70CP with hand-operated spools, all loads start moving at the same point, regardless of the size and direction of the load. The size of the load does, however, affect the slope of the curve to some extent.

Below are a few examples of how the P70CF can be connected up.

A. Series connection, multi-valve system, P70CF only

The pump is connected to the first valve. Flow that is not directed to a consumer via the first valve continues to the next valve. The first valve therefore has priority, i.e. in the event of full spool actuation in the first valve, no flow continues to the next valve.

If an additional pump is connected to valve 2, then valve 2 receives the flow from pump 2 plus any residual flow from valve 1.

B. Series connection, single-valve system, P70CF only

The pump is connected to the inlet section. Flow that is not directed out to consumers connected before the mid-inlet section continues to consumers connected after the mid-inlet section. This means that the first spool sections have priority, i.e. in the event of full spool actuation in a section before the mid-inlet section, no flow continues to the sections after the mid-inlet section.

If an additional pump is connected to the mid-inlet section, then subsequent sections will receive the flow from pump 2 plus any flow from pump 1 that has not been used by the sections before the mid-inlet section.

C. Parallel connection, multi-valve system

In parallel connection, the same pump is connected to two or more valves. The function is the same as if the pump were connected to a single large valve.

Parallel connection, fixed pump (CFO), P70CF

Parallel connection, variable pump (CP), P70CP

Parallel connection, variable pump (CPU), P70CP

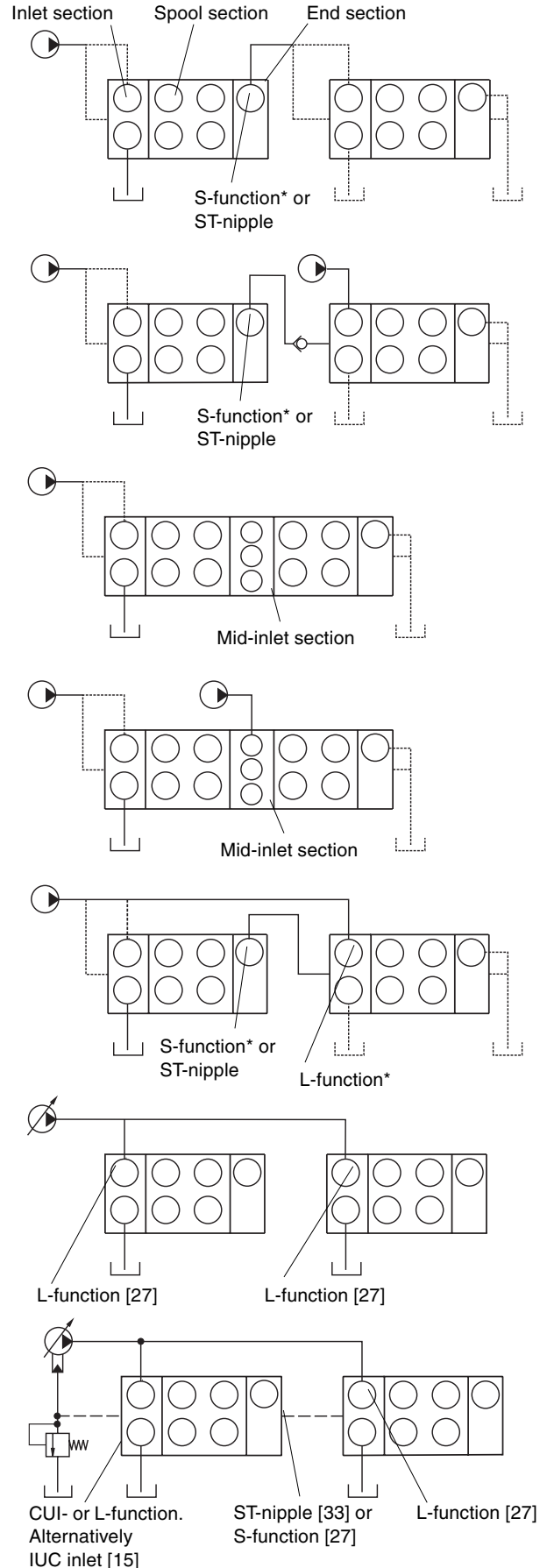

----- = Alternative connection

- - - - - = Signal line

* The different functions are described in more detail on pages 12, 15 and 18.

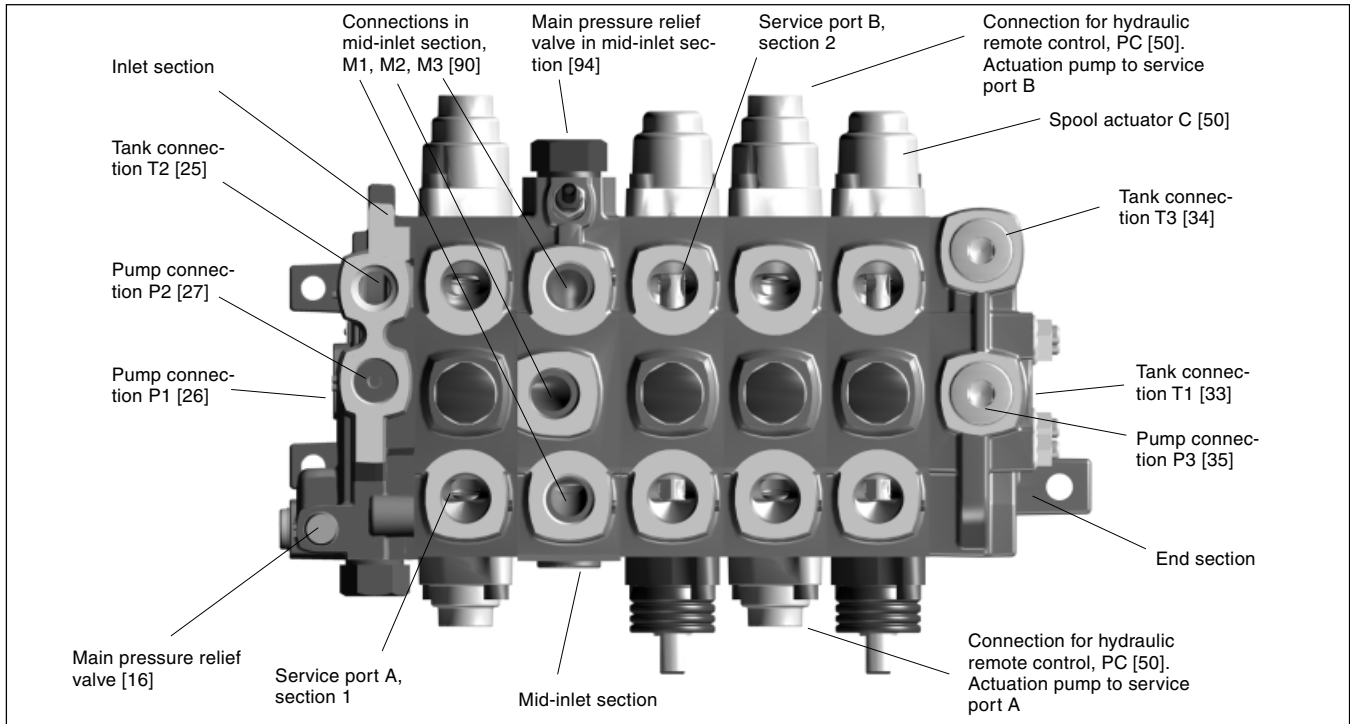

Pressures

Valve with:	Conventional spool sections*	Integrated spool sections*
Pump connection	max. 320 bar** (4640 psi)	max. 350 bar** (5075 psi)
Service ports	max. 350 bar** (5075 psi)	max. 380 bar** (5512 psi)
Tank connection, static	max. 10 bar (145 psi)	max. 10 bar (145 psi)

Flow rates (recommended)

P70CF. Pump connection	max. 70 l/min (18.5 USgpm)***
P70CP. Pump connection	max. 90 l/min (23.8 USgpm)***
P70CF. Return fr. service port	max. 100 l/min (26.5 USgpm)***
P70CP. Return fr. service port	max. 125 l/min (33.0 USgpm)***

Internal pilot pressure

Fixed setting	35 bar (508 psi)
---------------	------------------

Leakage from service port over spool

From A or B port: max. 75 cm³/min (4.58 cu.in/min) at 250 bar (3625 psi), oil temperature 50 °C (122 °F) and viscosity 30 mm²/s (cSt).

Weight

Since the weight will vary somewhat depending on the configuration of the valve, the values below are approximate.

Valve housing inclusive of spool, pressure relief valve etc. and inclusive of spool actuator.

Conventional inlet section	2.7 kg (6.0 lb)
Inlet with bypass	4.9 kg (10.8 lb)
Single spool section	3.1 kg (6.8 lb)
Single spool section for integrated spool actuator (CI, PCI)	4.2 kg (9.3 lb)
Single spool section for integrated spool actuator (EC, ECH)	4.6 kg (10.1 lb)
Mid-inlet section	2.5 kg (5.5 lb)
End section with pilot pressure supply	3.8 kg (8.4 lb)
End section	2.7 kg (6.0 lb)

Connections

Unless stated otherwise, all standard connections are available in two versions: G-version (BSP pipe thread) for flat seal (type Tredo) as per ISO 228/1 and UNF-version for O-ring seal as per SAE J1926/1.

Connection	Location	G-version	UNF-version
P1, P2	Inlet section	G1/2	7/8-14 UNF-2B
T2	Inlet section, I	G1/2	7/8-14 UNF-2B
T2	Inlet section, IU	G3/4	1-1/16-12 UN-2B
UL	Inlet section	G1/4	9/16-18 UNF-2B
M1, M2, M3	Mid-inlet	G1/2	7/8-14 UNF-2B
Service ports			
A and B	Spool section	G1/2	7/8-14 UNF-2B
PC	Spool section	G1/4	9/16-18 UNF-2B
P3	End section	G1/2	7/8-14 UNF-2B
T1, T3	End section	G1/2	7/8-14 UNF-2B
TP	End section	G1/4	9/16-18 UNF-2B
PS	End section	G1/4	9/16-18 UNF-2B

* See page 20

** Stated pressures are maximum absolute shock pressures at 10-bar tank pressure. See page 14.

*** Max. recommended flow rate dependent on choice of spool.

The valve can be mounted in all conceivable directions. However, the mounting base should be flat and stable so that the valve is not subjected to strain.

While the O-rings in the valve are normally of nitrile rubber, there are a number of special Viton variants. Please contact Parker for further information. In the P70CP, moreover, it is recommended that variant A002 be selected, so that the O-rings in the parting surfaces between the sections will be of Viton, since Viton withstands heat better than nitrile rubber. (Much heat is generated in a constant-pressure system that is working hard.)

Temperature

Oil temperature, working range +20 °C to 90 °C (68 to 194 °F)*

Filtration

Filtration must be arranged so that Target Contamination Class 20/18/14 according to ISO 4406 is not exceeded. For the pilot circuit, Target Contamination Class 18/16/13 according to ISO 4406 must not be exceeded.

Hydraulic fluids

Best performance is obtained using mineral-base oil of high quality and cleanness in the hydraulic system. Hydraulic fluids of type HLP (DIN 51524), oil for automatic gear-boxes Type A and engine oil type API CD can be used.

Viscosity, working range 15-380 mm²/s**

Technical information in this catalogue is applicable at an oil viscosity of 30 mm²/s and temperature of 50 °C (122 °F) using nitrile rubber seals.

* Product operating limits are broadly within the above range, but satisfactory operation within the specification may not be accomplished. Leakage and response will be affected when used at temperature extremes and it is up to the user to determine acceptability at these levels.

** Performance efficiency will be reduced if outside the ideal values. These extreme conditions must be evaluated by the user to establish suitability of the products performance.

Pressure drops

Pressure drop with the pump-unloading inlet

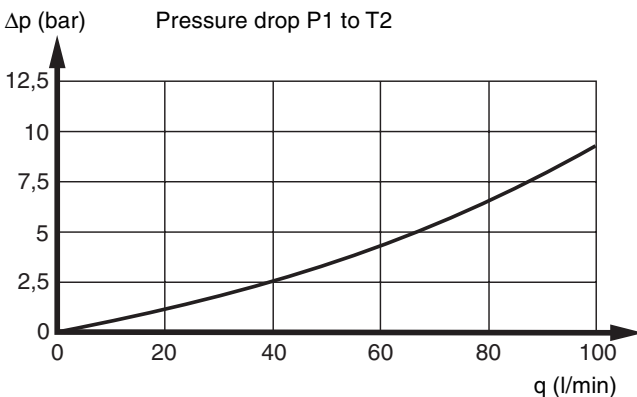

Pump unloading function. See description and hydraulic circuit diagram on page 14.

Valve with standard inlet section and end section

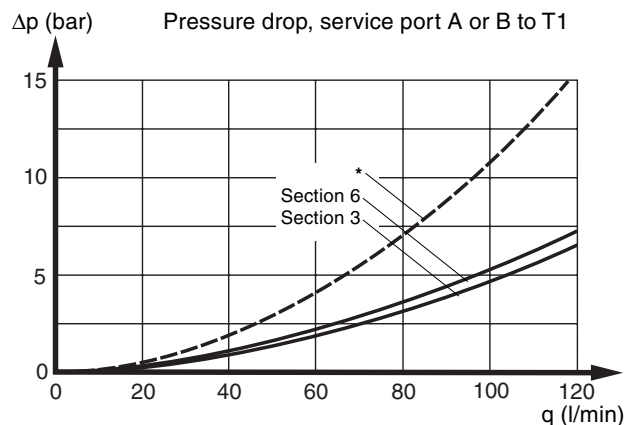
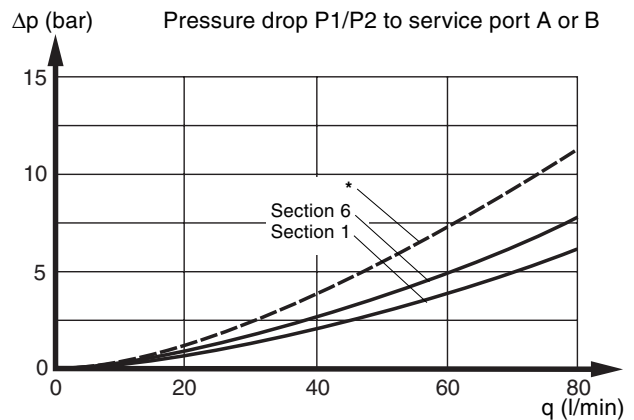
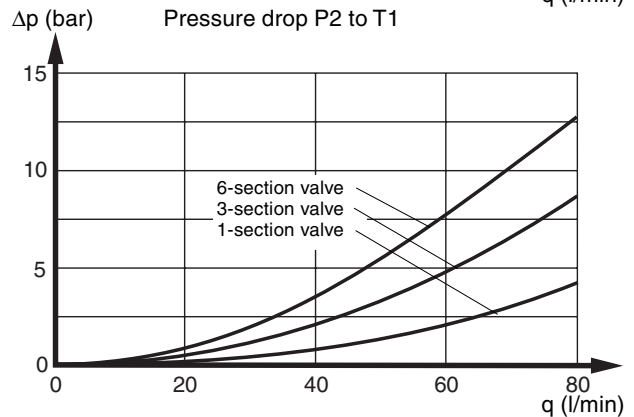
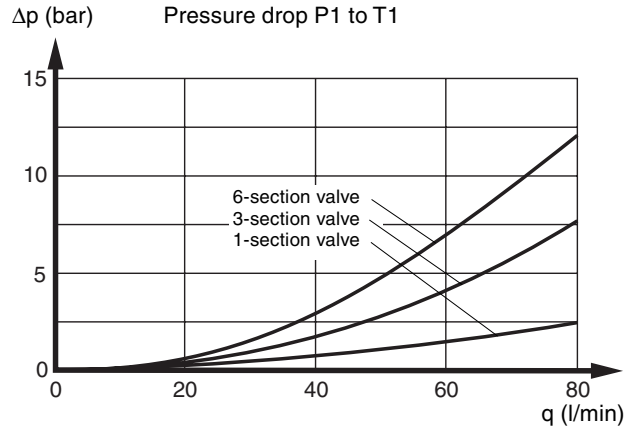

* Broken line illustrates example of pressure drop in P70CF over a D-spool for q=65 l/min in section 6.

Hydraulic circuit diagram showing basic functions, standard valve

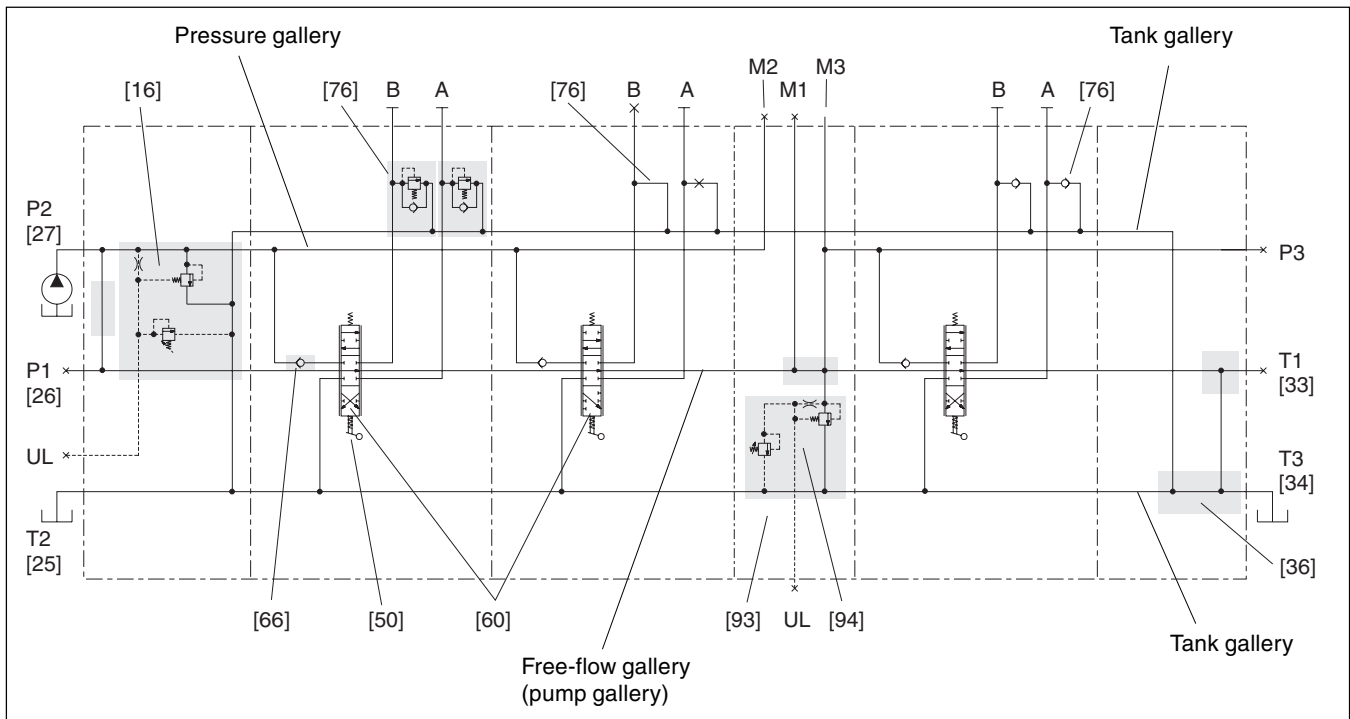

The circuit diagram above shows the P70CF with three spool sections and a mid-inlet between sections 2 and 3.

The shaded areas indicate functions or function groups that are described further on in the catalogue.

The item numbers in the hydraulic circuit diagram above and table below refer to function areas for which different options are available. The valve above is equipped as described below.

For details of other options available, and for the P70CP, please refer to the respective function areas [item numbers] given alongside the various sub-headings that begin on page 12.

Item No.	Code	Description	Item No.	Code	Description
16	PS	Adjustable main pressure relief valve in inlet.	66	N	Load-hold check valve in each section to prevent undesirable load sinking.
25	T2	Tank connection in inlet open.	76	PA	Combined port-relief and anti-cavitation valve in service ports A and B of sections 1.
26	P1B	Pump connection P1 in inlet plugged.		Y	Connection between service-port A and tank gallery blocked in section 2.
27	P2	Pump connection P2 in inlet open.		X2	Connection between service-port B and tank gallery open in section 2 (always the case with EA spool).
33	T1B	Tank connection T1 in end section plugged.		N	Anti-cavitation valves fitted in service ports A and B of section 3.
34	T3	Tank connection T3 in end section open.	93	C3	Mid-inlet with series connection to give priority to preceding sections. Intended for single or multi-pump operation.
35	P3B	Pump connection P3 in end section plugged.	94	PS	Adjustable main pressure relief valve in mid-inlet.
36	/	Free-flow gallery connected with tank.			
50	C	Spring-centred spool actuator on all sections for stepless operation by hand.			
60	D	Spool for double-acting function in sections 1 and 3.			
	EA	Spool for single-acting function working on service port A. Service port B blocked in section 2.			

Hydraulic circuit diagram showing basic functions (model with integral spool actuators)

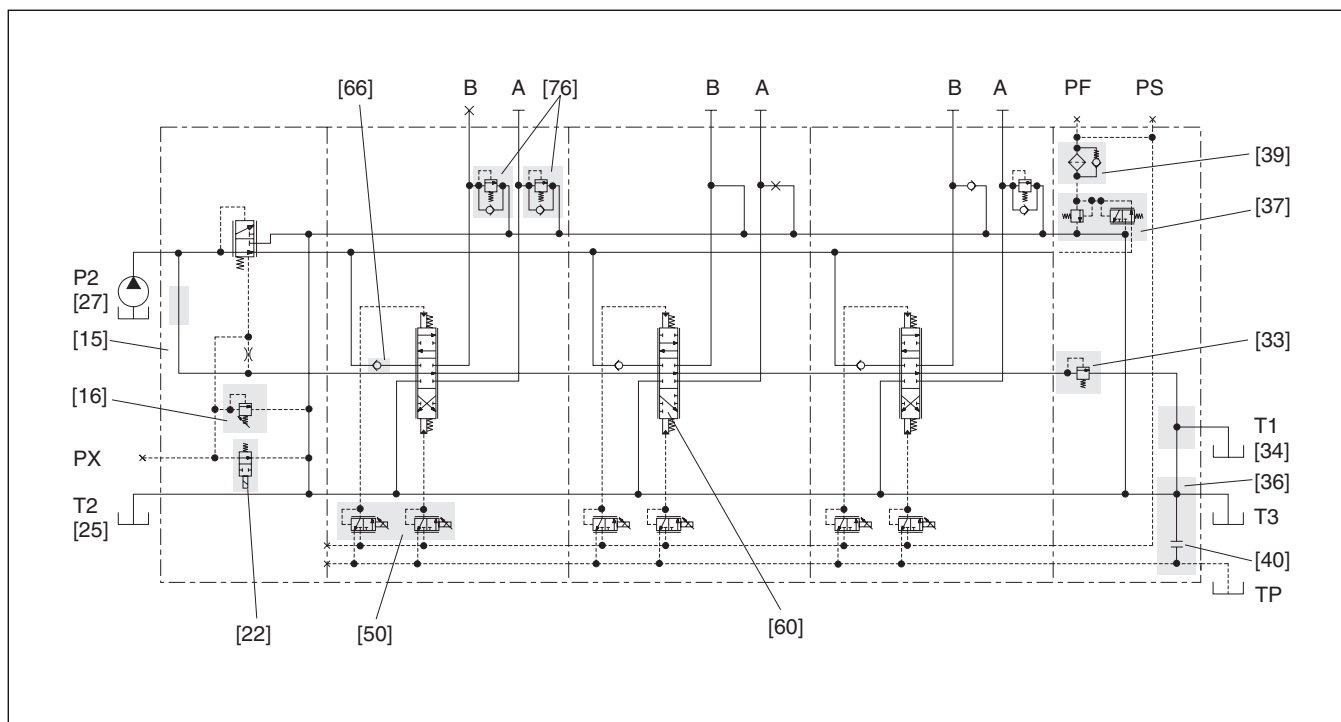

The circuit diagram above shows the P70 with three electro-hydraulically controlled spool sections and an integral pilot-oil

supply. The shaded areas indicate functions or function groups that are described further on in the catalogue.

The item numbers in the hydraulic circuit diagram above and table below refer to function areas for which different options are available. The valve above is equipped as described below.

For details of other options available, and for the P70CP, please refer to the respective function areas [item numbers] given alongside the various sub-headings that begin overleaf.

Item No.	Code	Description	Item No.	Code	Description
15	IU	Inlet with integrated bypass and pump-unloading function	60	D	Spool for double-acting function in sections 1 and 3.
16	PS	Adjustable main pressure relief valve in inlet.	EA		Spool for single-acting function working on service port A. Service port B blocked in section 2.
22	BEN	Electric pump-unloading function.	66	N	Load-hold check valve in each section to prevent undesirable load sinking.
25	T2	Tank connection in inlet open.	76	PA	Combined port-relief and anti-cavitation valve in service ports A and B of section 1 and service port A of section 3.
27	P2	Pump connection P2 in inlet open.	Y		Connection between service-port A and tank gallery blocked in section 2.
33	PT	Counterpressure function.	X2		Connection between service-port B and tank gallery open in section 2 (always the case with EA spool).
34	T1	Tank connection in end-section open.	N		Anti-cavitation valve fitted in service port B of section 3.
36	/	Free-flow gallery connected with tank.			
37	R35	Reducing valve for pilot-oil supply.			
39		Internal pilot-oil filter.			
40	TP	Separate tank connection for pilot oil.			
50	EC	Spool actuator for electric remote control.			

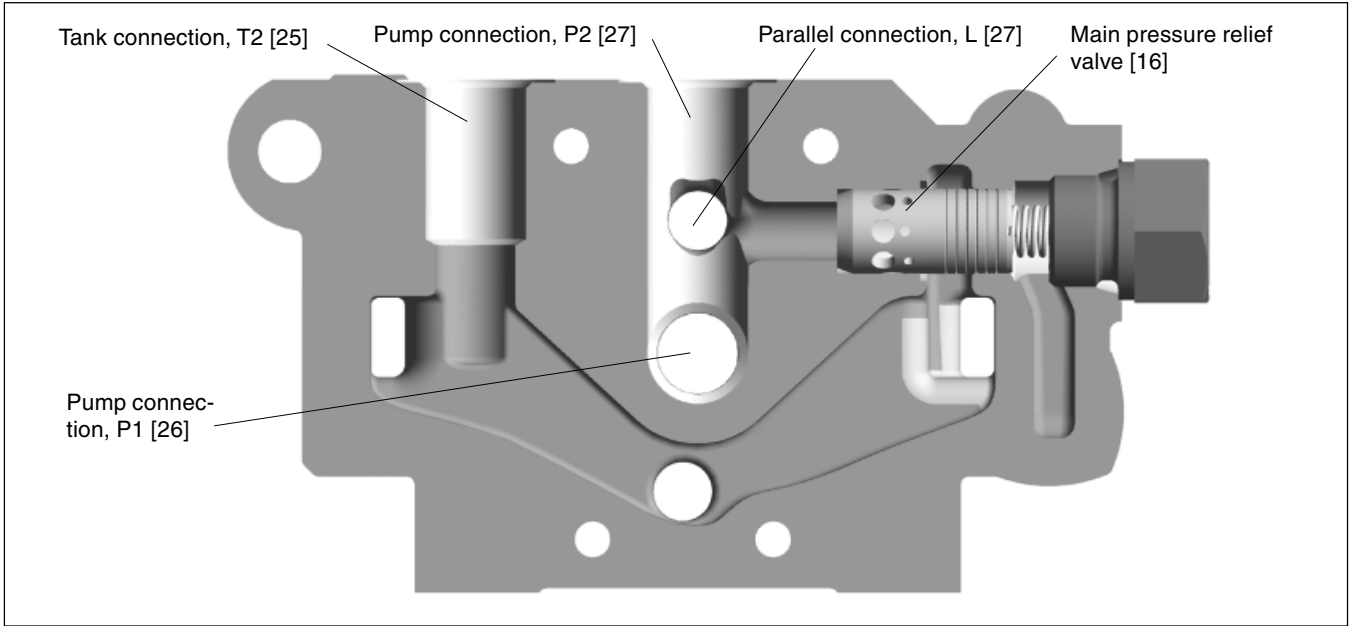

Standard inlet section

The inlet section comes in two basic versions: the standard version and a version with pump unloading.

The standard inlet section has two pump connections, P1 and P2, and a tank connection T2. The inlet section also contains the pilot-operated main pressure relief valve, in which either the UL connection for external pump-unloading or the multi-level pressure relief function are located (see page 15).

The P70 with closed centre (P70CP) is created by combining inlet I with L or CUI at item [27]. The difference between the P70CP and P70CF is that, in the P70CP, the free-flow gallery is used to break a hydraulic signal rather than to convey unused pump flow to tank.

Type of inlet section [15]

- I** Standard inlet (P70CF + P70CP).
- IU** Inlet with integrated pump-unloading function (P70CF).

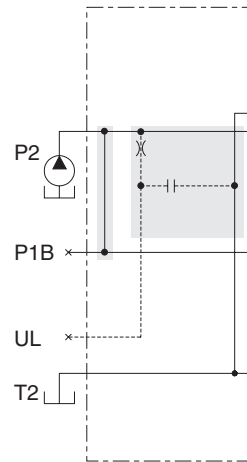

Standard inlet I without main pressure relief valve (P70CF).

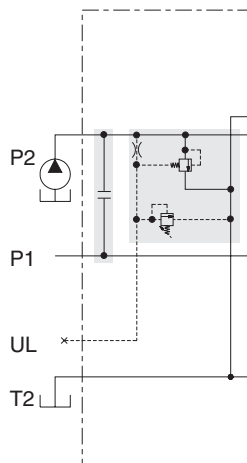

Standard inlet I with L-function and main pressure-relief function PS (P70CF).

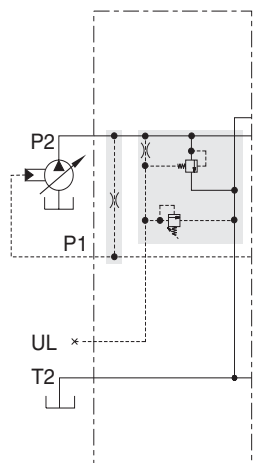

Standard inlet I with CUI-function and main pressure-relief function PS (P70CP).

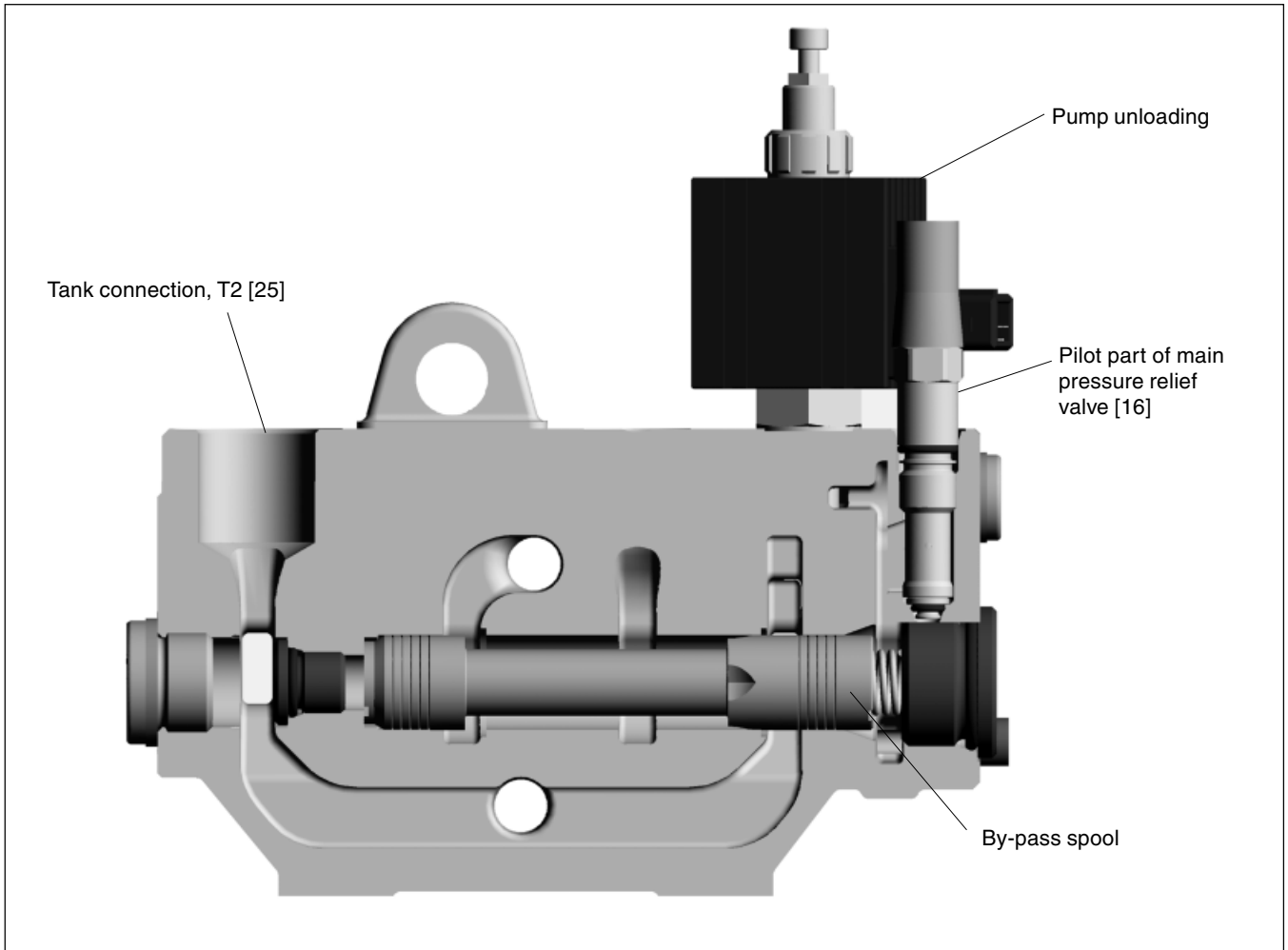

Inlet section for valve with integrated pump-unloading function.

The inlet section, IU, includes a pump-unloading function. This, together with some kind of overcentre valve, enables the machine manufacturer to equip the machine with an emergency STOP function.

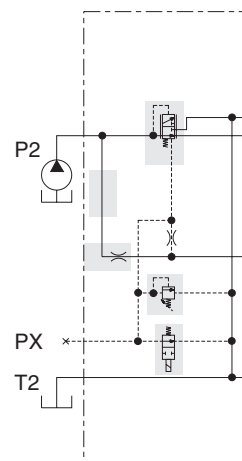

Inlet section with by-pass function, pump unloading and pilot-operated main pressure relief valve.

Main pressure relief valve [16]

The inlet section is equipped with an adjustable, pilot-operated pressure relief valve.

- PS** Adjustable main pressure relief valve. Pre-set at factory.
- PB** Adjustable main pressure relief valve. Supplied factory-set and sealed.
- Y** Without pressure relief valve.

Pressure setting [17]

Max. 320 bar. Settings above 350 bar can result in shorter service life. Please contact your nearest Parker representative for further information.

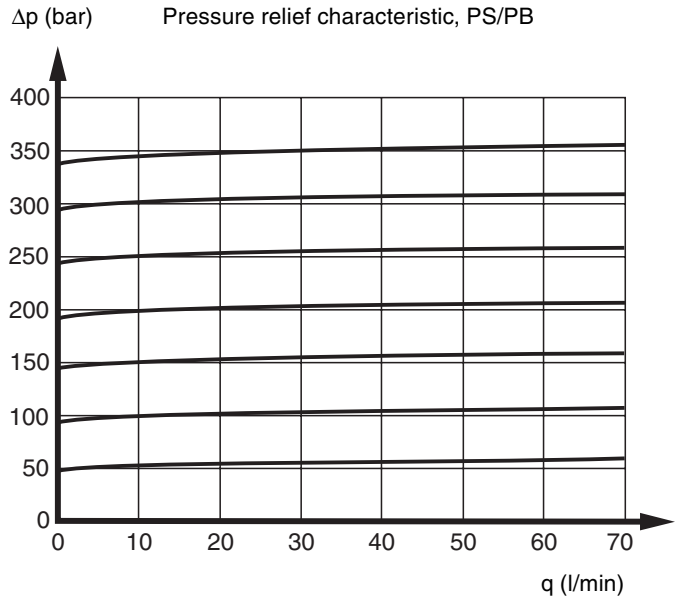

Pump unloading [22]

According to the EC Machinery Directive, machines must be equipped with one or more emergency STOP functions to enable actual or impending danger to be averted.

“The emergency STOP function must stop the dangerous process as quickly as possible without creating additional hazards and the energy supply to the function must be cut off.”

The pump-unloading inlet meets these criteria by diverting incoming oil from the pump directly to the tank line, at the same time blocking the pump line into the valve. This means that no energy is transmitted to the functions. It should be noted, however, that movements driven by dead weight will continue if there are no overcentre valves.

N.B. The pump-unloading function is a component of the machine safety system.

The energy supply to series-connected and downstream spool sections S [47] (see page 20) will not be cut off as stated above. The pump will indeed be connected with tank, but the pressure in the tank line can cause oil to flow into the pressure gallery via the series-connected section.

The pump-unloading function can also be used to save energy when the valve is not being used. By engaging the pump-unloading function when the valve is not being used, the pressure drop Pump-to-Tank falls. This function works just as well when downstream spool-sections are connected in parallel as well as in series.

The solenoid BEN [22] that controls the pump unloading function is available in 12 and 24 VDC versions. The solenoid is equipped with a manual activating device. For details on connectors, please see page 27.

- /** Inlet not equipped with pump unloading.
- BEN** Inlet equipped with electrically controlled pump unloading.
- BX** The inlet section is machined for the pump unloading function and plugged. This enables the pump unloading function to be installed at a later date, as well as the possibility of external control of pump unloading via port UL (see overleaf).

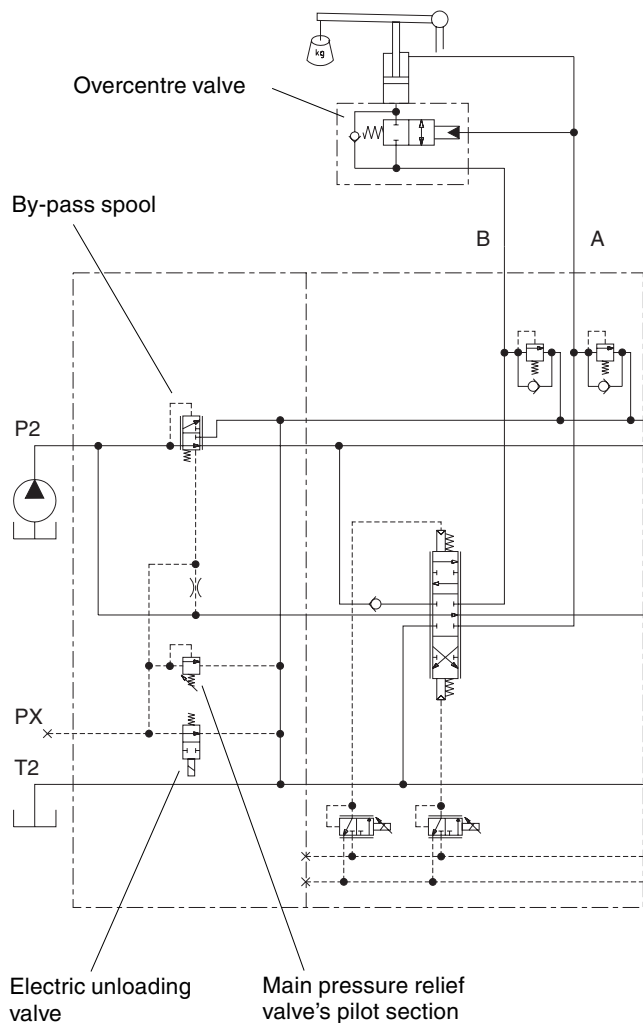

Circuit diagram for pump unloading

External pump unloading or multi-level main pressure relief function

Unloading can also be effected hydraulically by sending a hydraulic signal from connection UL (see pages 12 to 15) to external valves in an outer pilot circuit.

The unloading function can also be used to limit the maximum pressure for certain functions. In this way, high system pressures that arise when light loads bottom-out can be avoided.

By means of an external pilot-circuit connected to the pilot circuit (connection UL) of the main pressure relief valve, several pressure levels can be set as required. In this case, however, the external pilot valves must be set lower than the built-in one, and each must be connected to the pilot circuit by means of a two-way valve. The use of several different pressure levels will increase the service life of the system.

Tank connection T2 [25]

T2 Tank connection T2 open.

T2B Tank connection T2 plugged.

Pump connection P1 [26]

Not present on inlet types IU, IUC and IS [15].

P1 Pump connection P1 open. Normal version.

P1B Pump connection P1 plugged.

Pump connection P2 [27]

See page 7 for more information about parallel connection.

P2 Pump connection P2 plugged.

P2B Pump connection P2 plugged. Normal version.

L Parallel-connection used in P70CF when actual valve is connected downstream to another valve. The function separates the free-flow gallery from the pump gallery. (See page 12 for circuit diagram). Function not available for inlet types IU and IS [15].

CUI Unloading-signal restrictor for variable pump. Via the CUI restrictor (\varnothing 1.0 mm), the pump pressure enters the gallery that is used as the free-flow gallery on the P70CF. The inlet section I [15] is connected with the pump regulator via the P1 connection. When all spools are in neutral, the flow coming from the pump gallery passes via the CUI restrictor to the tank connection in the valve's end section. The pressure that influences the pump regulator does not arise. As soon as a spool is shifted out of neutral, however, the connection from the CUI restrictor to tank is broken and the pump pressure is again directed to the pump regulator via the P1 connection.

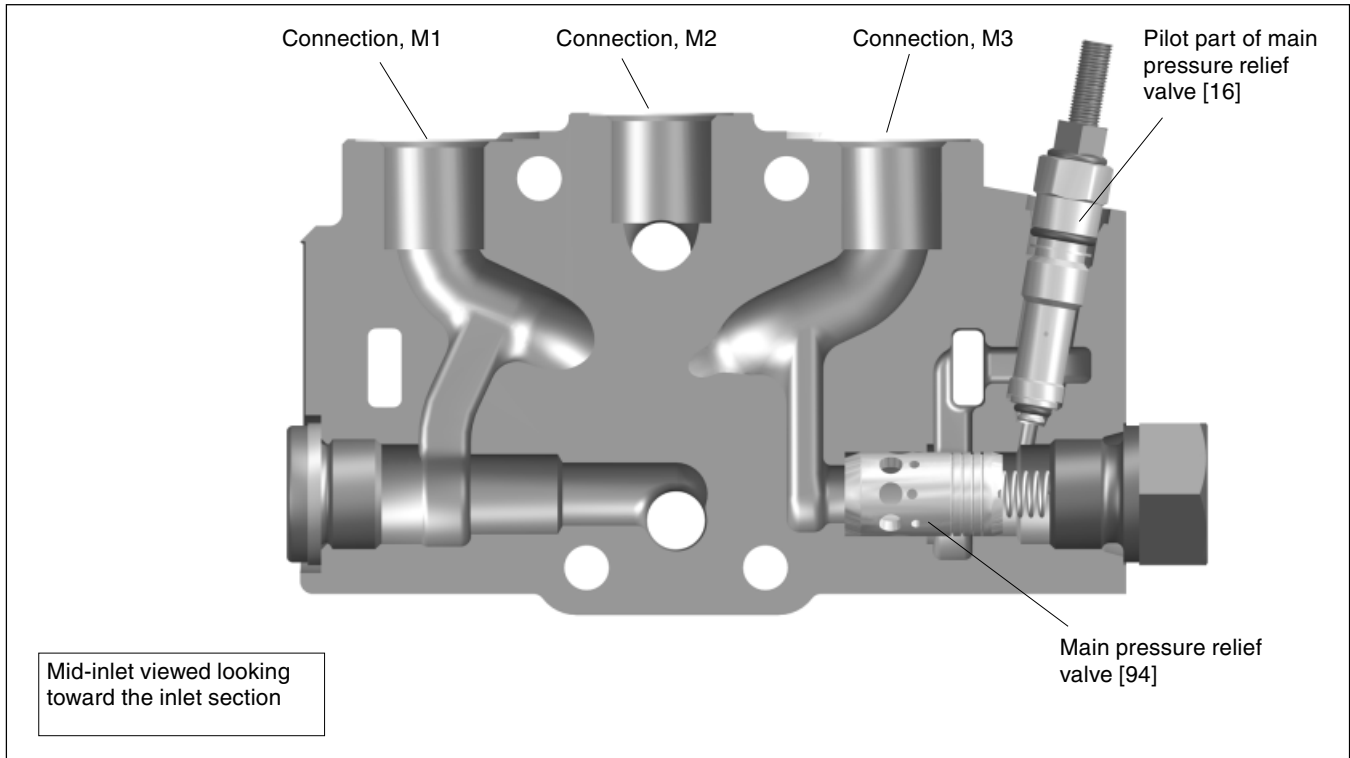

Mid-inlet section [90]

Many compact system solutions can be obtained with the aid of a mid-inlet section, which contains three connections connected in different ways, depending on the choice of options.

The main pressure relief valve (see page 17) can/or should be fitted in the mid-inlet, depending on the way in which the system is constructed. See connection alternatives overleaf.

Several mid-inlets can be placed in one and the same valve to give optimum system construction.

The mid-inlet section can only be selected for the P70CF equipped with conventional spool sections. See page 20.

Options, mid-inlet [93]

- C3** Mid-inlet with series connection that gives priority to upstream sections. Intended for single or multi-pump operation. Flow not used in sections upstream of the mid-inlet is added to the incoming flow in the mid-inlet.
- C5** Mid-inlet without flow summation. Intended for multi-pump operation. Valve with C5 mid-inlet functions as two separate valves with a common tank connection. If an extra tank line is connected to port M1, the pump-to-tank pressure drop will be reduced.
- C6** Mid-inlet with possibility of external series-connection via external check-valve between M1 and M3, with priority given to upstream sections, but without flow summation. Intended for multi-pump operation.

Main pressure relief valve [94]

The mid-inlet can be fitted with the same main pressure relief valve as is fitted in the standard inlet. For further information and technical data, please see Inlet section [16] on page 14.

In systems in which several different pressure levels are required, main pressure relief valves can be fitted to give different pressure levels before and after the mid-inlet.

- PS** Adjustable main pressure relief valve. Delivered with opening pressure pre-set as per specification.
- PB** Adjustable main pressure relief valve. Delivered pre-set and factory-sealed.
- Y** Without pressure relief valve.

Pressure setting [98]

Max. 320 bar. Settings above 350 bar can result in shorter service life. Please contact your nearest Parker representative for further information.

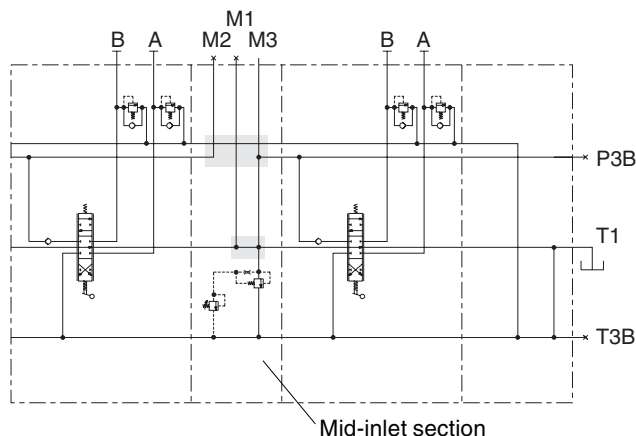

Mid-inlet, C3. Used in multi-pump systems and when upstream sections are to have priority over flow delivered by the pump connected to the inlet section [15]

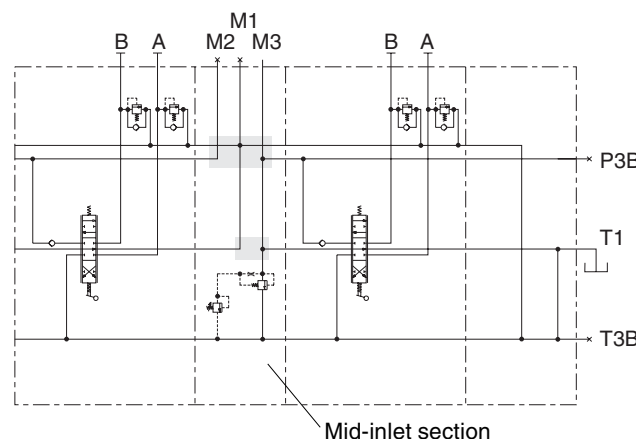

Mid-inlet, C5. Used in multi-pump systems. Valve functions as two separate valves, but with common tank gallery.

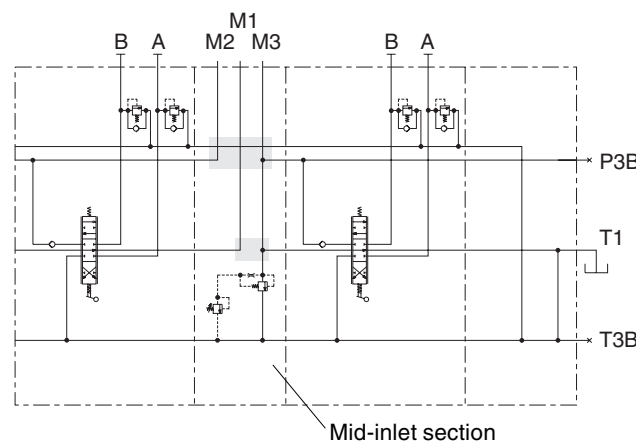

Mid-inlet, C6. Used in conjunction with prioritised section (series connected) for separate feeding (port M2) of non-prioritised sections upstream of the mid-inlet. See page 20.

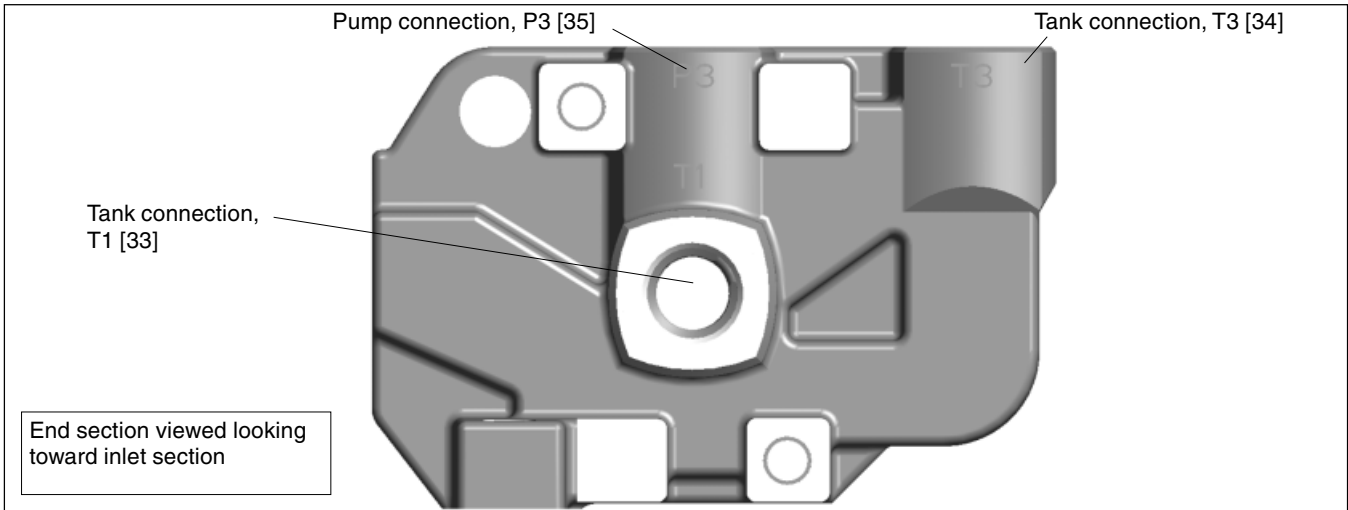

End section for standard valve

The end section is available in two different versions, the standard version and one with an integrated pilot-pressure supply. The standard end-section is equipped with a pump connection, P3, and two tank connections, T1 and T3. A series-connection function can be fitted in T3 to feed downstream valves. See page 7. For valves with integrated spool-actuators, the end section includes a pressure-reducing valve for the pilot-pressure supply, as well as a tank connection T4.

Type of end section [30]

US Standard end-section.

USP End section with pilot-pressure generation.

Tank connection T1 [33]

T1 Tank connection T1 open (normal version).

T1B Tank connection T1 plugged.

PT Counterpressure valve that raises pressure in free-flow gallery to ensure that the minimum requisite pilot-pressure is maintained (USP only).

ST Series connection nipple. Used to block the connection between the free-flow gallery and tank, at the same time directing the free-flow gallery's flow into a downstream valve. Tank connection T2 in the inlet or T3 in the end section must be open. Compare S at item [36]. On US end section only [30].

Tank connection T3 [34]

T3 Tank connection T3 open.

T3B Tank connection T3 plugged.

Series-connection function [36]

/ Without series connection.

S Series-connection function used to block connection between free-flow gallery and tank. Flow in free-flow gallery fed to subsequent valve through either T1 or T3 connection. Tank connection T2 in the inlet must be open.

Pump connection P3 [35]

P3 Used in conjunction with series-connected section (see page 20) for separate feeding of non-prioritised sections downstream of prioritised section. Not available for end section type USP.

P3B Pump connection P3 plugged.

Spool section **Standard end-section**

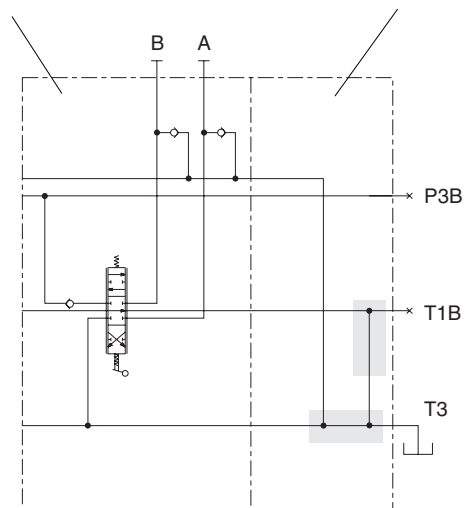

Tank connection T3 open. Free-flow gallery connected with tank gallery in the end section.

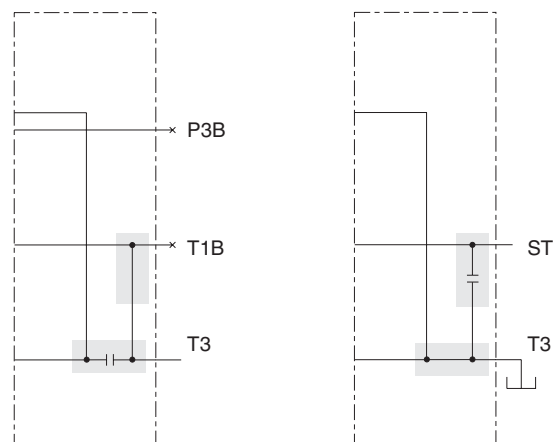

End section equipped with S-function. The free-flow gallery's connection with the tank gallery is blocked.

Tank connection T3 open. Free-flow gallery not connected with tank (series connected). ST at item [33].

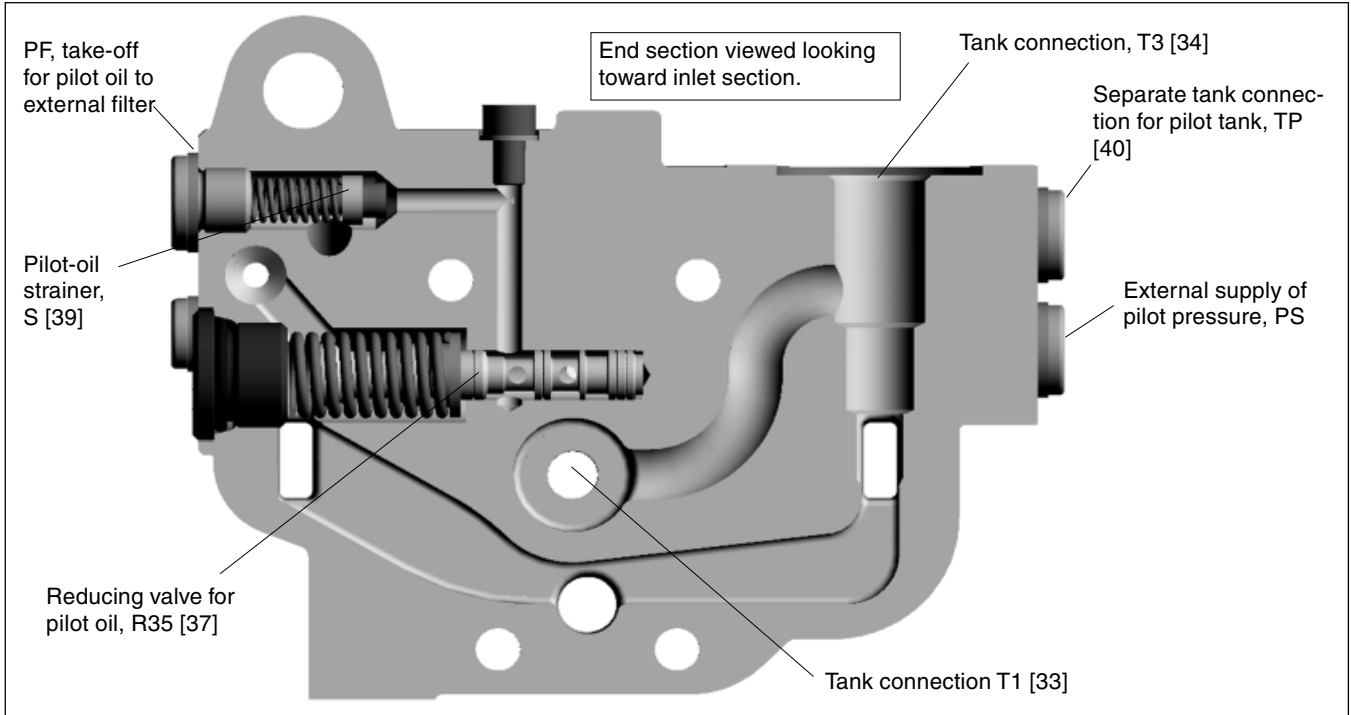

End section with integral pilot-oil supply

Reducing valve [37]

Internal pilot-pressure supply is a valve function built into the end section, which acts both as a reducing valve and a pressure relief valve in the pilot circuit. For safety reasons, it is furnished with a separate safety valve function that prevents the maximum permissible reduced pressure from being exceeded.

A pilot pressure for external use, e.g. for the PCL4 remote-control valve, can be tapped via the PS connection.

- / Without reducing valve
- R35** Reducing valve set at 35 bar.

Pilot-oil strainer [39]

- S** Coarse filter with by-pass function in the internal pilot-pressure supply. Filter protects pilot circuit from dirt, especially during start-up of system.
- YS** Adaptor for connection of external pilot-pressure filter. Enables pilot circuit to be supplied with cleaner oil compared with the rest of the system.

Separate tank connection for pilot circuit [40]

- TP** Separate tank connection for pilot circuit is open. The connection to the main tank gallery in the directional valve is blocked. This function is suitable for systems in which there is a risk of dynamic pressure variations in the tank line causing variations in the pilot circuit when there is a common tank line.
- TPB** End section machined for separate tank connection for pilot circuit, and plugged. Tank return of pilot circuit connected with tank gallery of directional valve.
- TPC** The pilot circuit's tank gallery is connected to the main tank gallery via a check valve. The check valve is used to prevent that a pressure peak reaches the spool actuators.

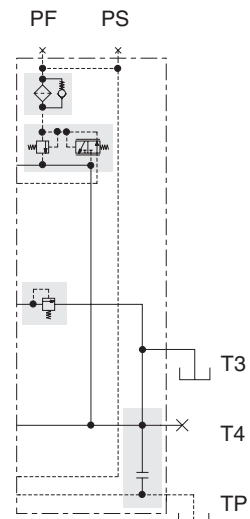

Tank connection T3 open. Free-flow gallery connected with tank via counterpressure function, PT [33].

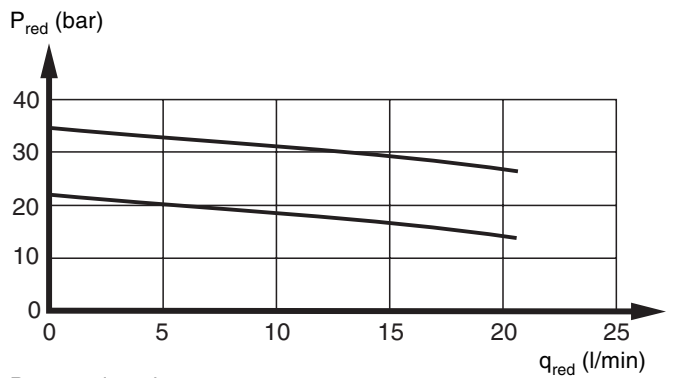

P_{red} = reduced pressure
q_{red} = take-off flow from reducing valve

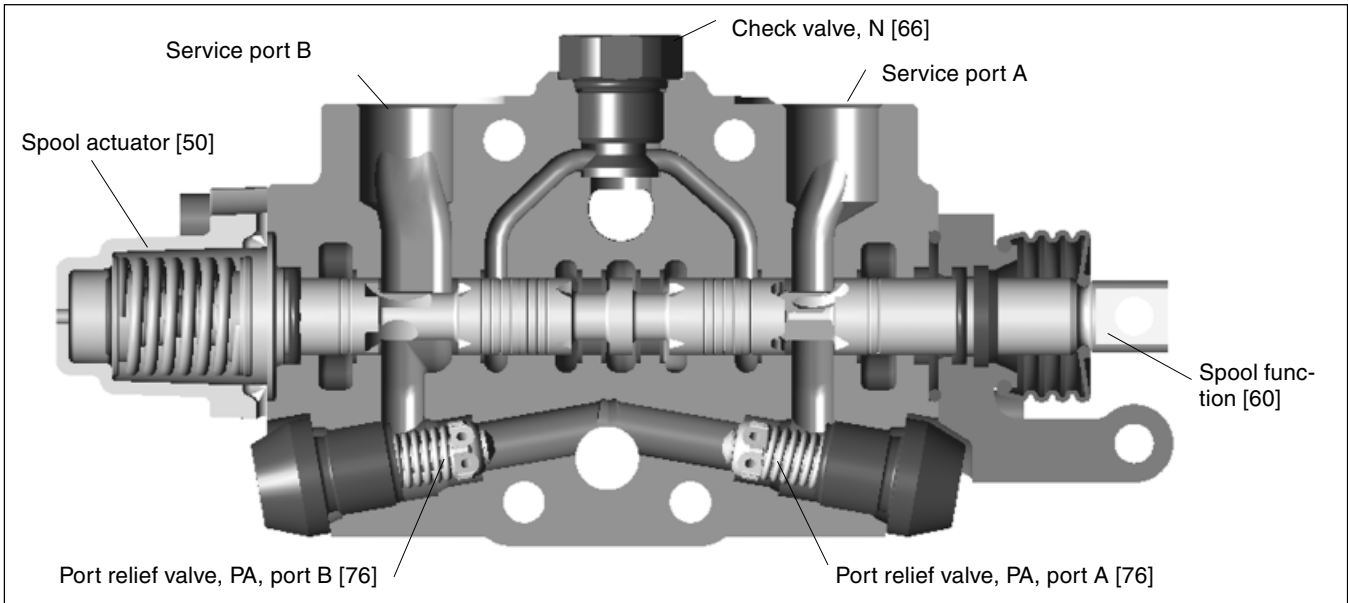

Conventional spool section, P, with open pressure gallery for parallel connection

The P70CF is stackable and can be supplied in combinations of 1 to 10 spool sections. For each spool section, there is a wide range of spools and spool actuators to choose between. This enables optimal adaptation of individual spool sections to suit the application and controlled function. The spool sections have machined control edges for precise control characteristics. For best economy, the spool sections are available in two basic versions:

- spool sections for conventional spool actuators
 Conventional spool section, see picture above.
- spool sections with integral spool actuators
 Integral spool section, see pictures on page 23.

Spool sections for conventional spool actuators for the P70CF are also available in a version in which the upstream sections are prioritized (series connected). This is achieved by breaking the pressure-gallery connection with upstream sections, at the same time as a connection with the free-flow gallery has been created. Connection corresponds to mid-inlet option C3 for one pump (see page 17).

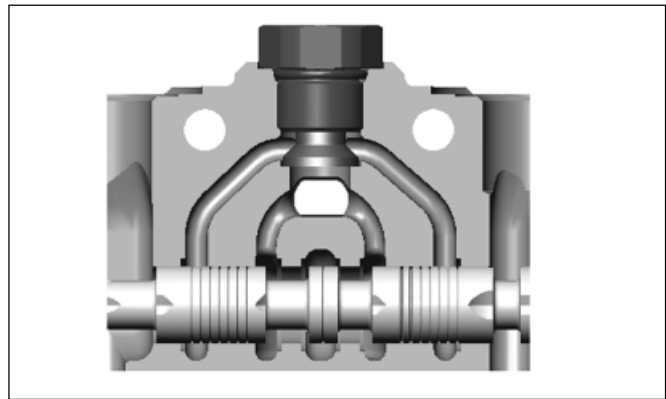

Conventional spool section, type S, with broken pressure-gallery connection for tandem connection

Type of spool section [47]

- P** Parallel-connected section
- S** Tandem connected (previously known as series connected) section for prioritisation of upstream sections. Note that the pump unloading BEN [22] function changes. Please see page 14.

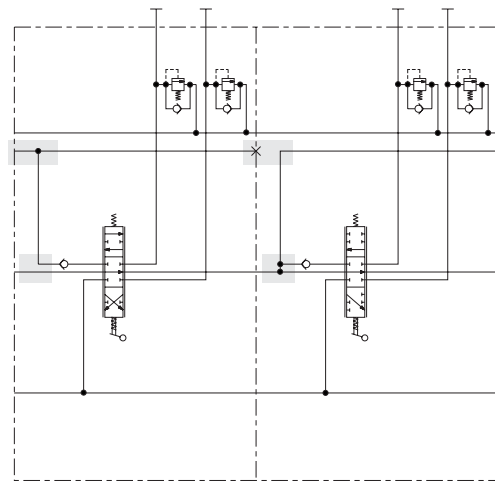

The section on the left is a parallel-connected section, while the one on the right is tandem connected. This means that the section on the left has priority over available flow.

Spool Sections

Lever bracket [51]

- LMA** Lever bracket for open spool actuator. Lever itself not included. Must be ordered separately (see page 27).
- LMB** Lever bracket for open spool actuator. Lever itself not included. Must be ordered separately (see page 27).
- LU** No lever bracket – open spool end.
- **** Spool in (←) gives actuation P-A, B-T.
Spool out (→) gives actuation P-B, A-T.

Spool actuators [50]

A large number of spool actuators is available for the P70CF. They are divided into three different groups: hand-operated, ON/OFF remote controlled and proportionally remote controlled.

Hand-operated spool actuators with open spool end

- C/C140** Spring-centered spool actuator. Actuator for stepless control with spring centering to neutral position. C140 has stronger centering force. Recommended when cable control or mechanical linkages are used.
- B2C** Three-position, spring-centered spool actuator. The B2C has mechanical detents at the two end positions, so that the spool stays in place when fully actuated in either direction. It must be shifted out of the respective end positions manually.
- CB** Float-position spool actuator. The CB is a special actuator for F-spools (see page 25). It features stepless operation, with spring centering from the two end positions to neutral. It also has a fourth position with a mechanical detent. The spool must be shifted out of the fourth position manually.

Remote controlled ON/OFF spool actuators with open spool end and possibility of manual control

- ACE** An electro-pneumatic ON/OFF control with spring centering and the possibility of stepless operation by means of a lever.

Primary air:	4 – 10 bar
Control current:	12 VDC min. 0.85 A 24 VDC min. 0.42 A
Voltage tolerance:	± 20%

The spool actuator has a common pressure gallery for primary air. The primary air can be connected to either the first or the last valve section directly by means of a plug-in connector for Ø6 mm air hose.
- ACP** A pneumatic proportional spool actuator with spring centering and the possibility of stepless operation by means of a lever. The ACP is best controlled by the Parker VP04 remote control valve.

Breakaway pressure:*	2 bar
Final pressure:*	7 bar
Permissible air pressure in pilot cap	Max. 10 bar

Connections: G1/8 or NPTF 1/8-27

* See annotation on page 22.

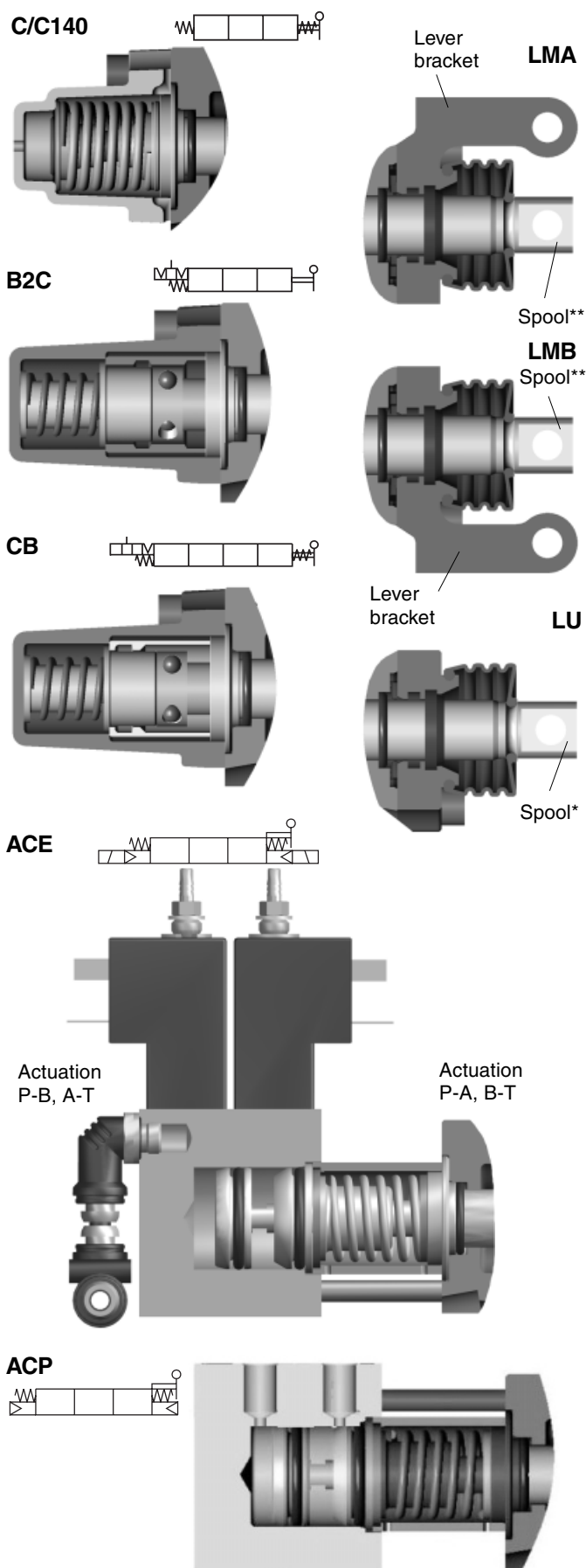

Remote controlled proportional spool actuators with closed spool end

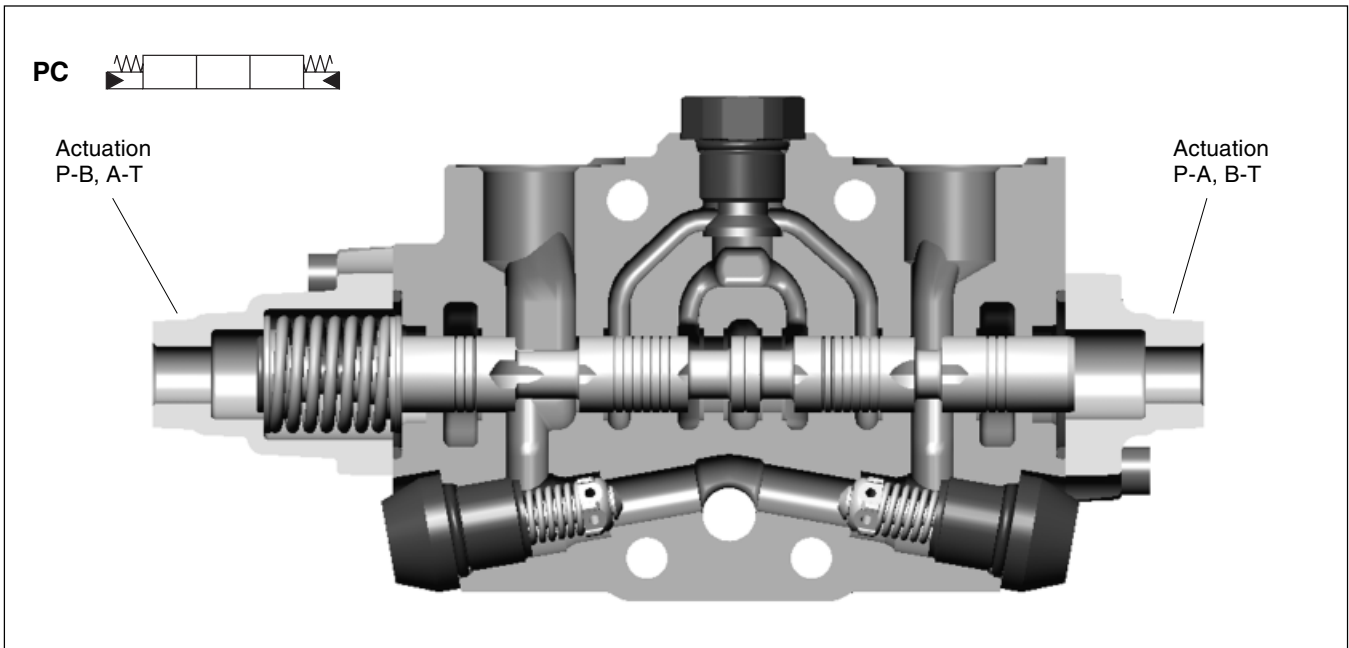

PC Hydraulic, proportionally controlled, spring-centred spool actuator. Best controlled by PCL4 remote control valve (see separate brochure).

Breakaway pressure:* 6 bar
 Final pressure:* 17 bar
 (max. 35 bar)

Connection thread: G1/4 or 9/16-18 UNF

FPC Hydraulic, proportionally controlled, spring-centered spool actuator with a fourth position for shifting the spool into the float position.

Breakaway pressure:* 6 bar
 Final pressure:* 16 bar
 (max. 18 bar)

Pressure for float position: min. 24 bar
 (max. 35 bar)

Connection thread: G1/4 or 9/16-UNF-2B

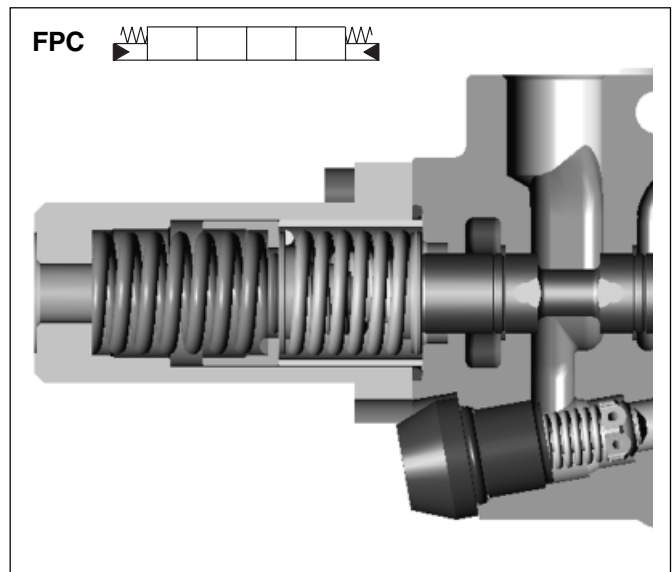

* The breakaway pressure refers to the pressure needed for the directional valve to open the connection "pump to service port". The final pressure is the lowest pressure needed to effect full actuation of a spool in the directional valve. With the FPC spool actuator, the float position is obtained by further increasing the final pressure from max. 18 bar to min. 24 bar. The foregoing data must be taken into consideration when choosing control units, since the opening pressure of the control unit must be lower than the breakaway pressure of the spool actuator in order to avoid jerky starting and stopping. However, the control unit's final pressure must be higher than the final pressure of the directional valve in order to ensure that the spools can be fully actuated. This is important for the P70CF because, if the spool is not actuated fully, the free-flow gallery will not close, with the result that a certain amount of flow will go directly to tank.

Proportional spool-actuators with closed spool end

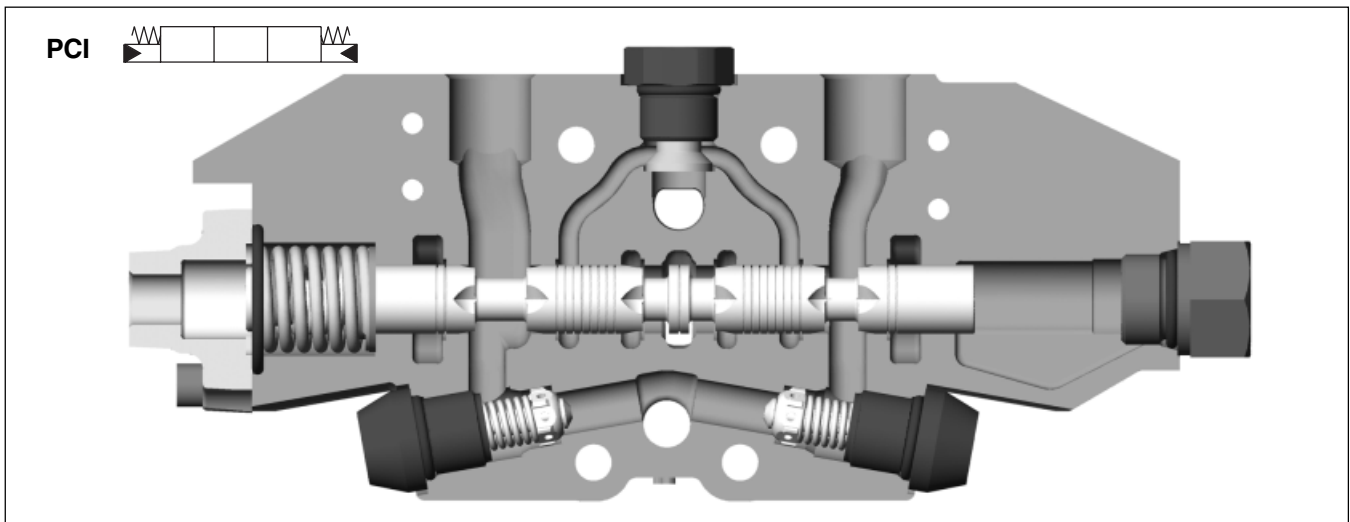
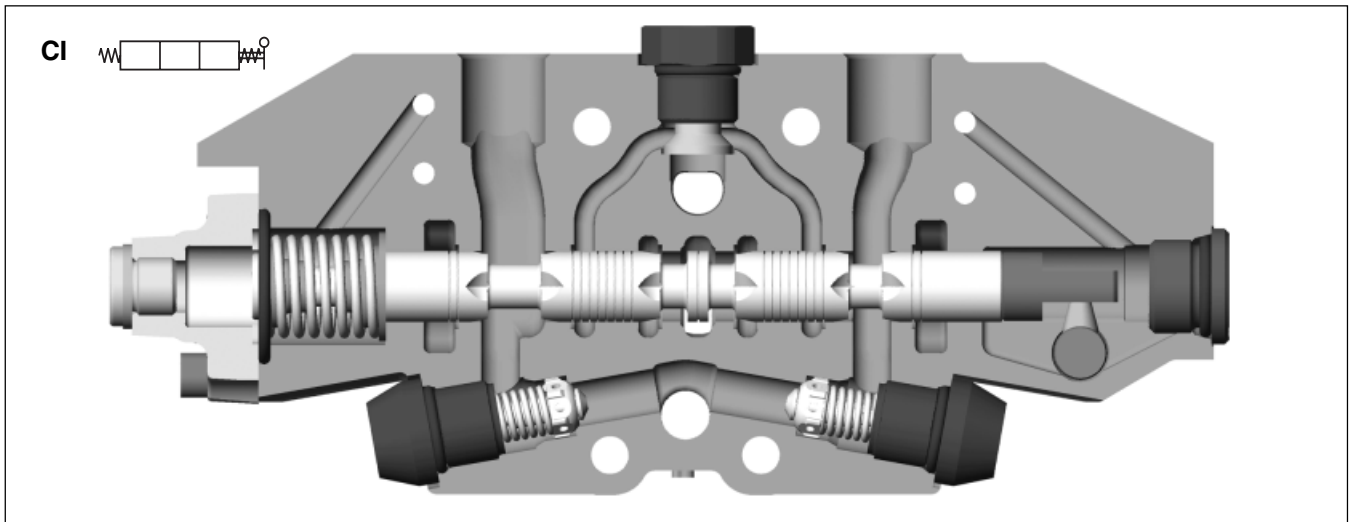

CI Spring-centred spool actuator
 Stepless, spring-centred spool actuator with enclosed spool ends for use in tough environments. The CI is also suitable for use when hand-operated spool actuators are required in combination with remote controlled spool-actuators such as the EC and ECH on one and the same valve.
 Compare with C-type spool actuator.

PCI Hydraulic, proportional, spring-centred spool actuator, controlled (ideally) by our PCL4 remote control valve (see separate brochure).
 The PCI is intended for use when spool sections for integrated spool-actuators are required, e.g. in combination with EC or ECH spool actuators on one and the same valve.
 Compare with PC spool actuator.

Breakaway pressure:* 6 bar
 Final pressure:* 17 bar
 (max. 35 bar)

Connection thread: G1/4 or 9/16-18 UNF

* See annotation on page 22.

Remote controlled proportional spool actuators with closed spool end and possibility of manual operation

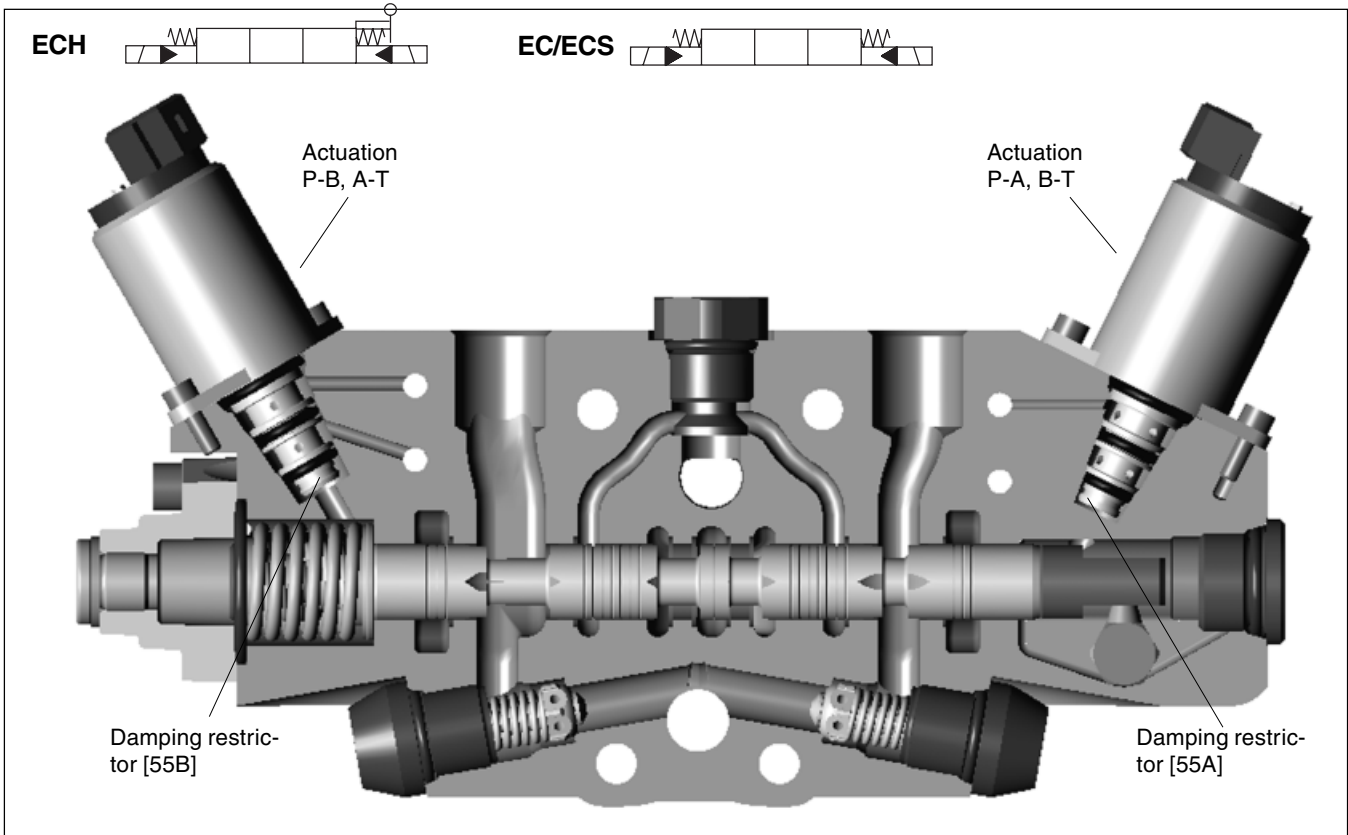

ECS Electro-hydraulic proportional spool actuator
 The ECS is an electro-hydraulically, proportionally controlled, spring-centred spool actuator. The PVC25 cartridge valve is used as its remote control valve.

The ECS spool actuator is best controlled by means of a Parker electric remote-control system (see separate brochure). The electrical connector must be ordered separately (see page 27).

Voltage	12 V	24 V
Breakaway current:*	max. 500 mA	max. 260 mA
Final current:*	min. 1010 mA	min. 510 mA
Solenoid (PVC25):	max. 1450 mA 100% ED	max. 730 mA 100% ED

Coil resistance at +20 °C:	5.4 Ω	21.7 Ω
Inductance:	27.7 mH	7.0 mH

Tank pressure: max. 15 bar max. 15 bar

EC The EC spool actuator have the same data as the ECS. The difference is that the solenoid valve in the EC is also equipped with manual-override and air bleeding functions.

ECH As above, but with possibility of stepless operation by means of a hand lever. Valve is delivered with lever bracket, but lever itself must be ordered separately (see page 27).

* The breakaway current refers to the current needed for the directional valve to open the connection "pump to service port". The final current is the lowest current needed to effect full actuation of a spool in the directional valve. This data must be taken into consideration when choosing control units, since the opening current of the control unit must be lower than the breakaway current of the spool actuator in order to avoid jerky starting and stopping. However, the control unit's final current must be higher than the final current of the directional valve in order to ensure that the spools can be fully actuated. This is important for the P70CF because, if the spool is not actuated fully, the free-flow gallery will not close, with the result that a certain amount of flow will go directly to tank.

The spool is the most important link between the actions of the operator and the movement of the controlled function. Parker therefore goes to great lengths to optimise spools for different flows, load conditions, functions and applications. Since this is a process of continuous development work, new spools are being introduced all the time. For this reason, the many different spools available are not detailed in this catalogue. Parker's computerised specification program will generate proposals for suitable spools for the application and functions of the hydraulic system in your machine.

Spool function [60]

Spools are divided into different groups, depending on their basic function.

- D** Double-acting spool. Blocked in the neutral position.
- EA** Single-acting spool. Blocked in the neutral position and service port B blocked.
- EB** Single-acting spool. Blocked in the neutral position and service port A blocked.
- M** Double-acting spool. Service ports connected to tank (float position) in neutral.
- F** Double-acting spool with fourth position in which both service ports are connected to tank (float position). Blocked in neutral position.
- CA** Regenerative spool for rapid feeding of a cylinder, or for flow saving. The large side of the cylinder is always connected to service port A.

Certain spools have been equipped with drainage from service port to tank when the spool is in neutral. Drainage (approx. 2 mm²) serves to prevent pressure build-up in the service port. Such drainage is used primarily in combination with different types of external overcentre valve. The spool designation is affected as follows: A lower-case letter is suffixed to the usual spool designation indicating function, e.g. the D-spool becomes a Da-spool to indicate drainage from service-port A to tank.

- a** Drainage of service-port A to tank
- b** Drainage of service-port B to tank
- m** Drainage of service ports A and B to tank

Spool designation [69]

Each spool version is imprinted with an alphabetical code to facilitate identification during tuning or servicing in the field.

Pressure gallery [66]

- N** Load-hold check valve to prevent undesirable sinking of a heavy load while a light load is operated.

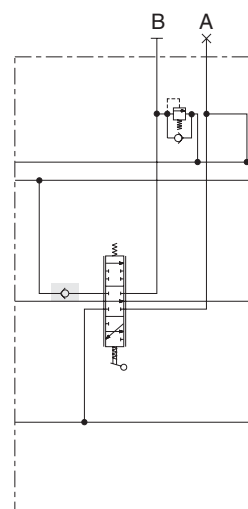
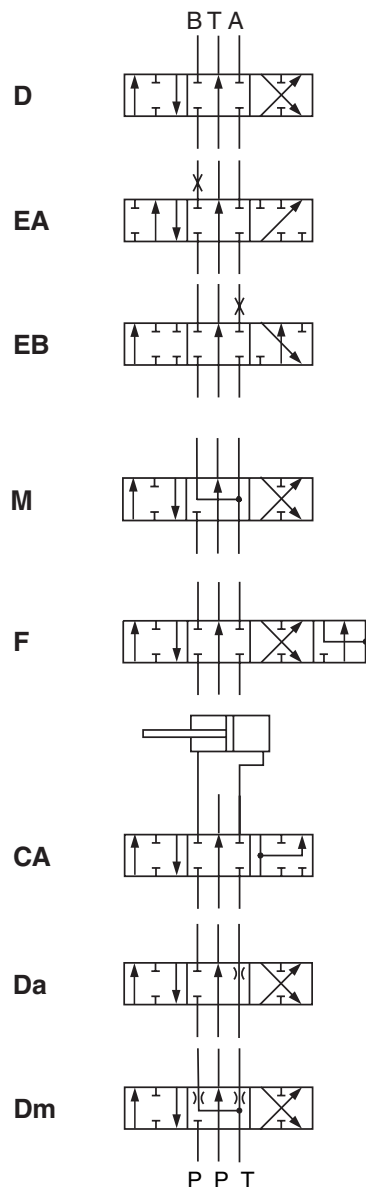

Pressure gallery fitted with check valve (N).

**Pressure limiters in service ports [76A/B]
 (Port relief valves)**

The service ports can be equipped with individual port-relief and/or anti-cavitation valves.

PLC053 cartridge valves are used as port relief valves. They are renowned for their long service life, tightness, fast opening sequence and good characteristics over the entire flow range.

Port relief valve [76]

- / Hole for port relief valve not machined.
- X2** Service port connected permanently with valve's tank gallery.
- Y2** Connection between service port and tank gallery blocked.
- N2** Anti-cavitation valve fitted. The anti-cavitation valve serves to ensure that, in the event of a lower pressure in the service port than in the tank, oil can be sucked from the system oil tank to the consumer. To improve the anti-cavitation function, the oil tank can be pressurised. Note that the counterpressure valve PT [33] does not influence the pressure in the anti-cavitation valve's tank line.
- PA** PLC053 combined port-relief and anti-cavitation valve fitted. Valve is factory-set at the specified pressure. Optional pressure settings: 50, 63, 80, 100, 125, 140, 160, 175, 190, 210, 230, 240, 250, 260, 280, 300, 320 and 350 bar.

Since the cavities for X2, Y2, N2 and P2 have the same machining, it is easy to change the function of an existing valve.

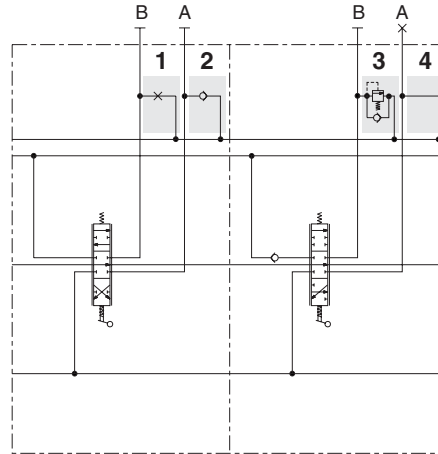

In the diagram above:

- Section 1, service port B, is fitted with a Y2-plug (1) to block the connection to tank.
- Section 1, service port A, is fitted with an anti-cavitation valve N2 (2).
- Section 2, service port B, is equipped with a combined port-relief and anti-cavitation valve (3) to limit the pressure and prevent cavitation.
- Section 2, service port A, is connected to tank - X2 variant - in the case of EB spools (4).

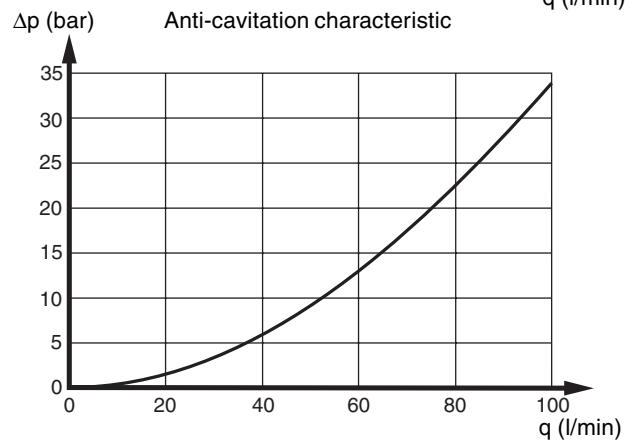
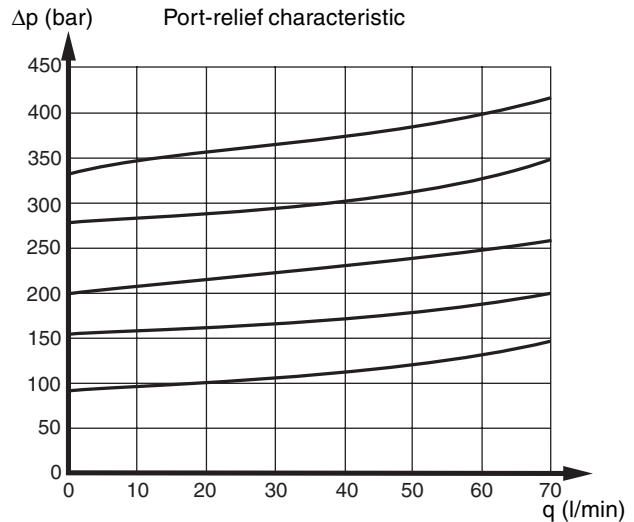

The curve shows the pressure drop between the tank connection and service port when port relief valve (PA) or anti-cavitation valve (N) without port-relief function is used as an anti-cavitation valve.

Function blocks (manifolds)

P70CF valves can be equipped with manifold-type function blocks that enable total system solutions to be integral into the valve.

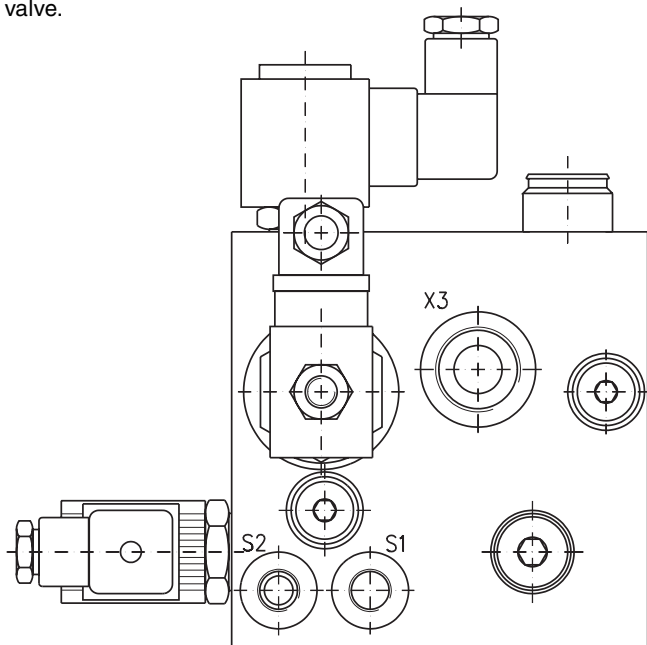

Please contact your Parker representative for more information about integral system solutions. In addition to standard function blocks, special function system blocks can be designed by our experienced product and system designers to meet your needs exactly.

The function block above was specially adapted for a customer. Like most of our function blocks, it was constructed with the aid of cartridge valves. Only the housing itself is a unique component.

Connectors

Connectors are not included with spool actuators, and should be ordered separately as per the lists below.

Spool actuators EC, ECS and inlet section with pump-unloading

Suitable connectors are the:
 AMP Junior-Timer type C, 963040-3
 or Bosch 1 928 402 404.

Assembly kits complete	1 off	393000K822
with pins and seals can be	10 off	393000K825
ordered using the kit	50 off	393000K826
numbers opposite.	100 off	393000K827

Spool actuator ACE

Suitable connector is Hirschman.
 Complete connector sets can be ordered on following set numbers:

1 st	9125 9551 00
10 st	9125 9551 10
25 st	9125 9551 25
50 st.	9125 9551 50
100 st	9125 9551 99

Hand levers

Levers are not supplied with the valve and must therefore be ordered separately.

They are furnished with window-type knobs, so that machine builders can insert the appropriate function symbol beneath a transparent cap to indicate the function of the lever. Levers are supplied complete with mounting kits.

Mechanical co-ordinate levers (joysticks) can be supplied on request. Please contact Parker for further information.

Lever:	Längd L mm	L (inch)	Ordering No.
MP1	179	(7.05)	8234 9390 21
MP2	214	(8.43)	8234 9390 22
MP3	202	(7.95)	8234 9390 23
MP6	122	(4.80)	8234 9390 26

Hand levers for open spool-actuators

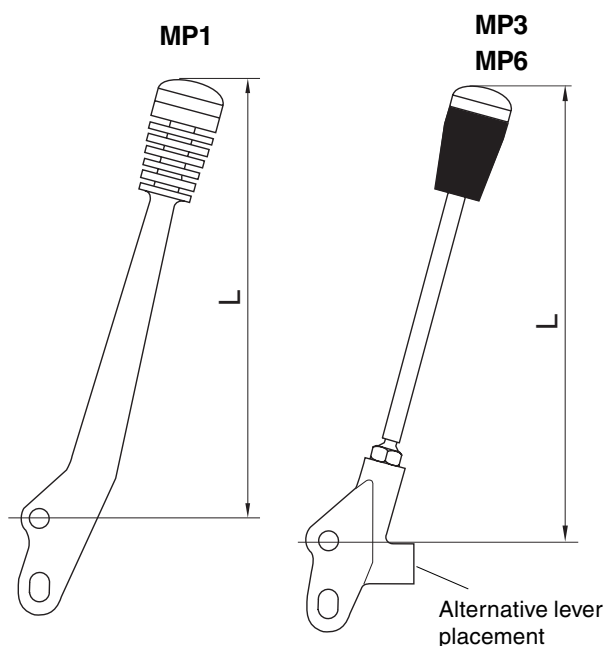

Hand levers for closed spool-actuators

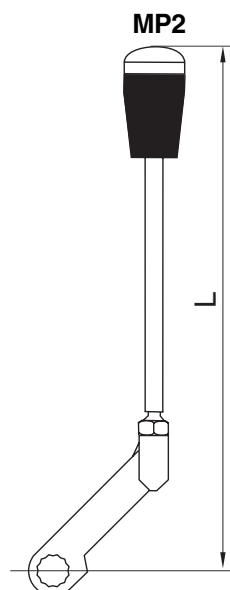

Standard valve

(inch)

For connection dimensions, please see page 8.

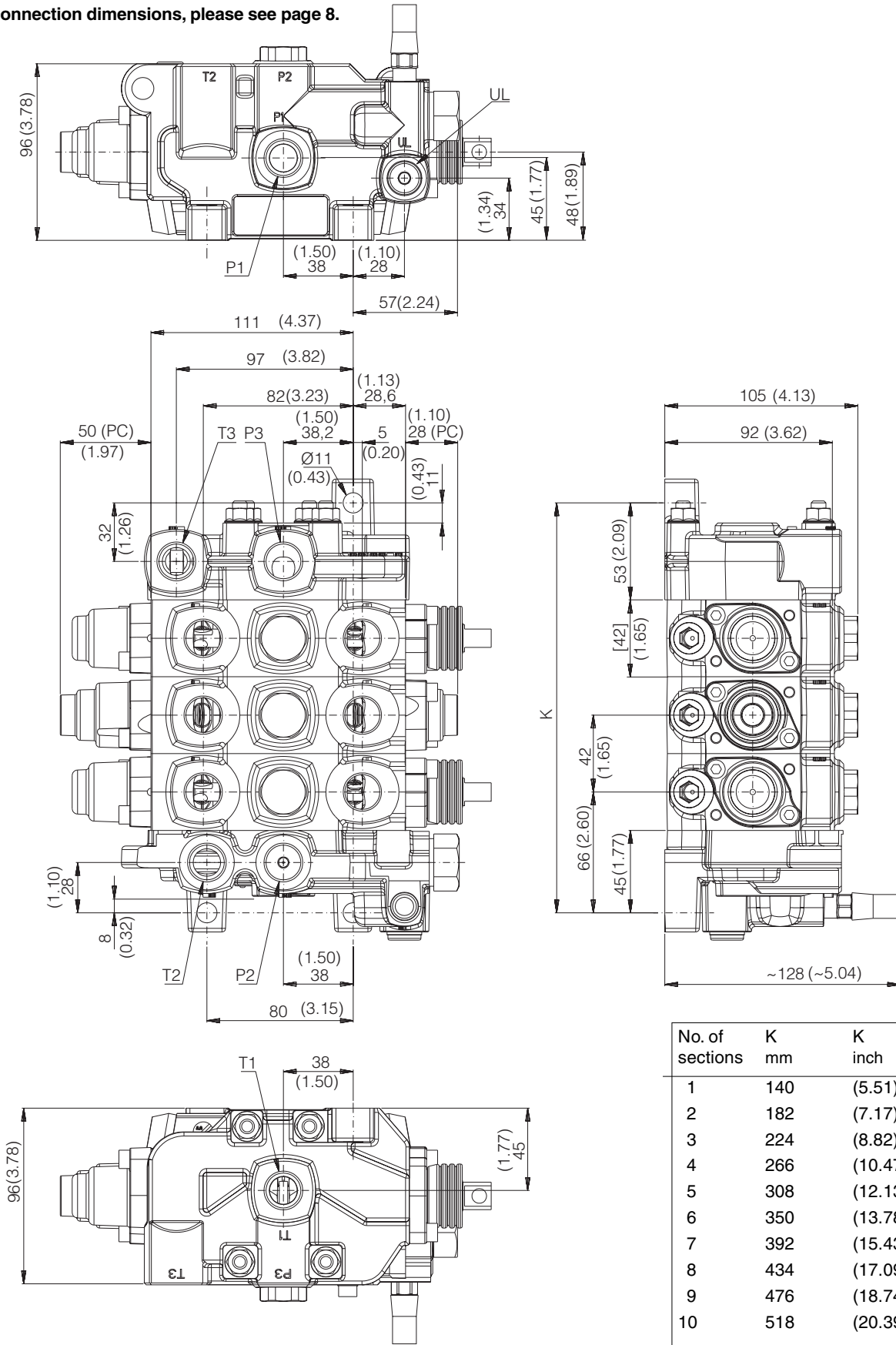

No. of sections	K mm	K inch
1	140	(5.51)
2	182	(7.17)
3	224	(8.82)
4	266	(10.47)
5	308	(12.13)
6	350	(13.78)
7	392	(15.43)
8	434	(17.09)
9	476	(18.74)
10	518	(20.39)

Model with integral spool actuators

For connection dimensions, please see page 8.

(inch)

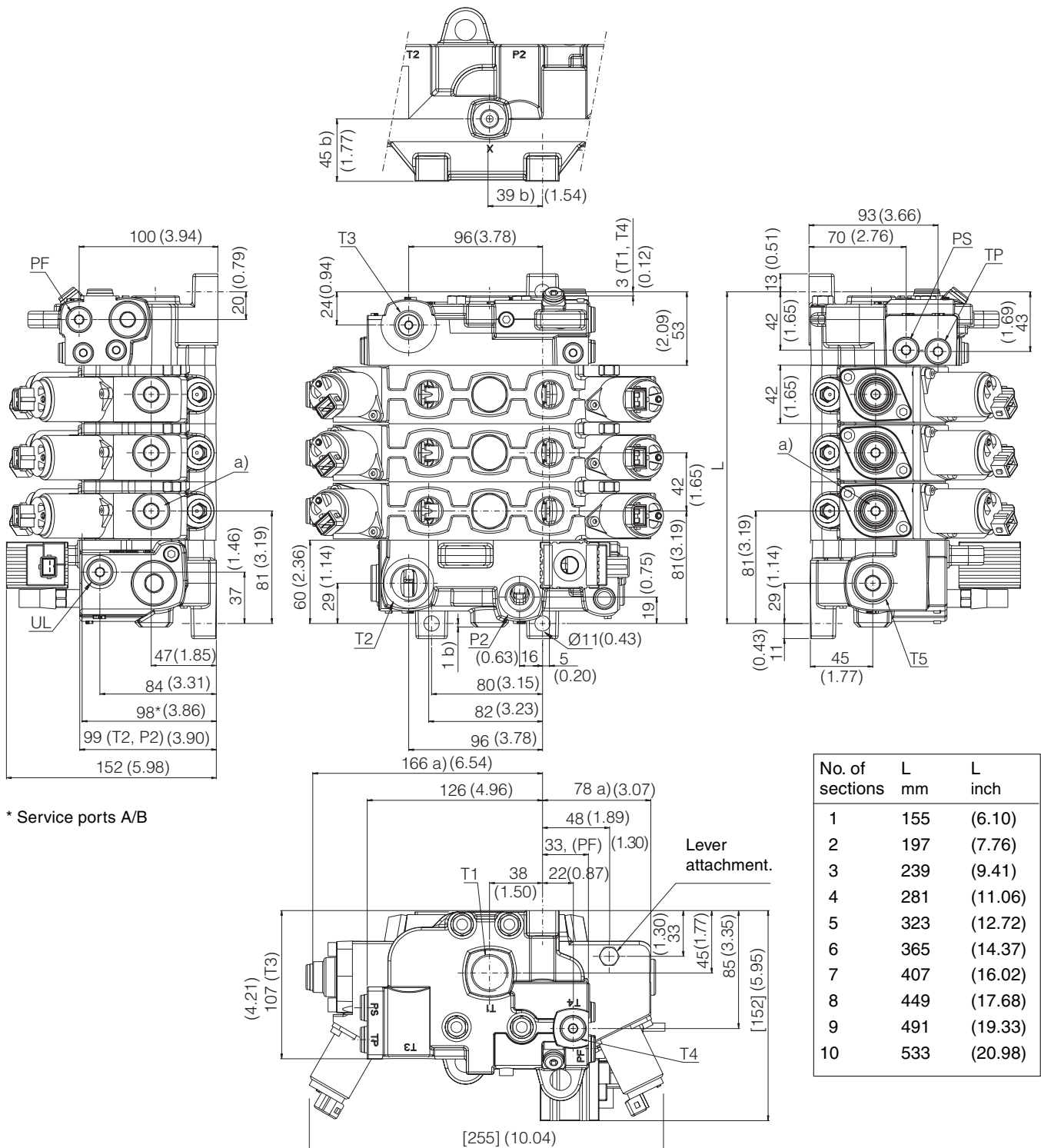

* Service ports A/B

a) Pilot-pressure connection, PCI spool actuator
 b) Signal connection X on IUC inlet section

Spool actuators

C

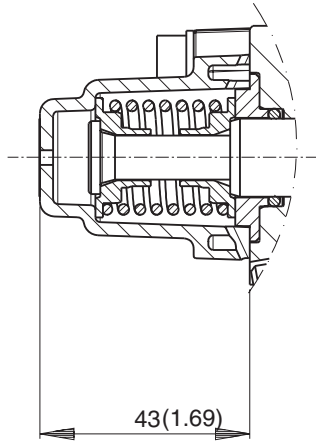

B2C

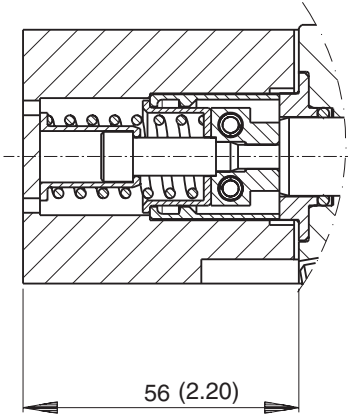

CB

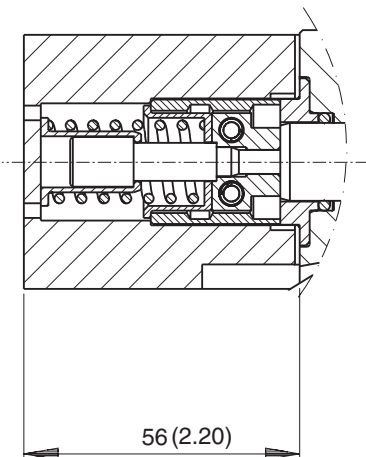

LMB

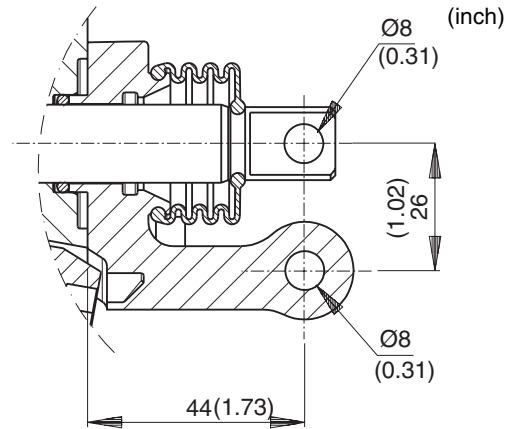

LU

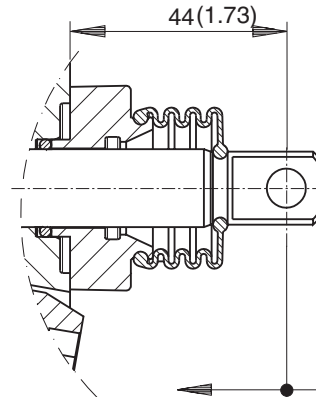

Spool stroke 12.5 mm (0.49) for spool function F [60]. Others 6.0 mm (0.24). Opens pump to service port A.
 Spool stroke 6.0 mm (0.24); opens pump to service port B.

ACE

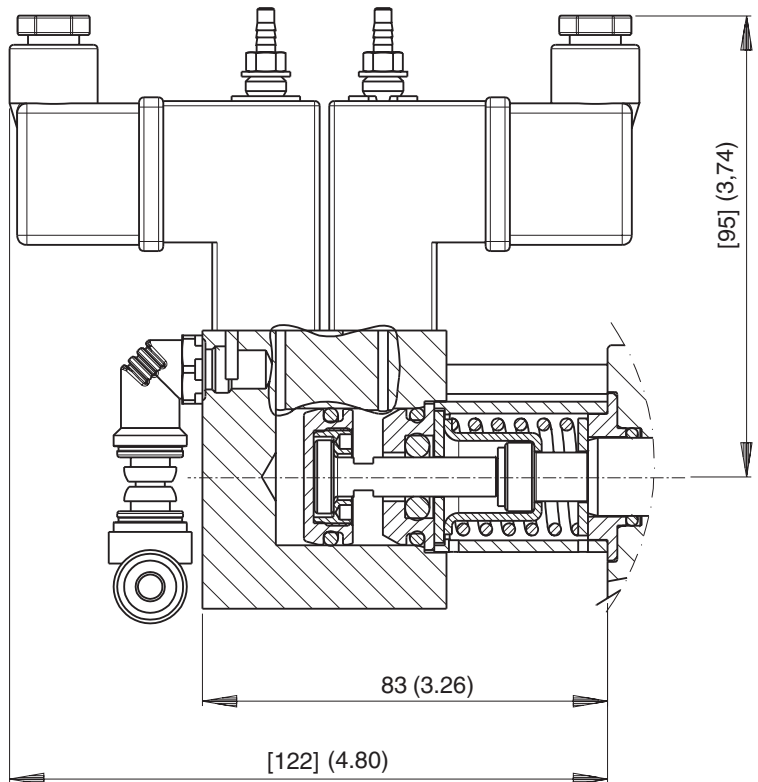



WARNING

FAILURE OR IMPROPER SELECTION OR IMPROPER USE OF THE PRODUCTS AND/OR SYSTEMS DESCRIBED HEREIN OR RELATED ITEMS CAN CAUSE DEATH, PERSONAL INJURY AND PROPERTY DAMAGE.

This document and other information from Parker Hannifin Corporation, its subsidiaries and authorized distributors provide product and/or system options for further investigation by users having technical expertise. It is important that you analyze all aspects of your application, including consequences of any failure, and review the information concerning the product or system in the current product catalogue. Due to the variety of operating conditions and applications for these products or systems, the user, through its own analysis and testing, is solely responsible for making the final selection of the products and systems and assuring that all performance, safety and warning requirements of the application are met.

The products described herein, including without limitation, product features, specifications, designs, availability and pricing, are subject to change by Parker Hannifin Corporation and its subsidiaries at any time without notice.

Offer of Sale

Please contact your Parker representation for a detailed "Offer of Sale".

Hydraulics Group Sales Offices

Europe

Austria

Wiener Neustadt
Tel: +43 (0)2622 23501
Fax: +43 (0)2622 66212

Belgium

Nivelles
Tel: +32 (0)67 280 900
Fax: +32 (0)67 280 999

Czech Republic

Klecany
Tel: +420 284 083 111
Fax: +420 284 083 112

Denmark

Ballerup
Tel: +45 4356 0400
Fax: +45 4373 8431

Finland

Vantaa
Tel: +358 (0)9 4767 31
Fax: +358 (0)9 4767 3200

France

Contamine-sur-Arve
Tel: +33 (0)450 25 80 25
Fax: +33 (0)450 03 67 37

Germany

Kaarst
Tel: +49 (0)2131 4016 0
Fax: +49 (0)2131 4016 9199

Hungary

Budapest
Tel: +36 (06)1 220 4155
Fax: +36 (06)1 422 1525

Ireland

Dublin
Tel: +353 (0)1 293 9999
Fax: +353 (0)1 293 9900

Italy

Corsico (MI)
Tel: +39 02 45 19 21
Fax: +39 02 4 47 93 40

The Netherlands

Oldenzaal
Tel: +31 (0)541 585000
Fax: +31 (0)541 585459

Norway

Ski
Tel: +47 64 91 10 00
Fax: +47 64 91 10 90

Poland

Warsaw
Tel: +48 (0)22 863 49 42
Fax: +48 (0)22 863 49 44

Portugal

Leca da Palmeira
Tel: +351 22 9997 360
Fax: +351 22 9961 527

Slovakia

Ref. Czech Republic

Spain

Madrid
Tel: +34 91 675 73 00
Fax: +34 91 675 77 11

Sweden

Spånga
Tel: +46 (0)8 597 950 00
Fax: +46 (0)8 597 951 10

Turkey

Merter/Istanbul
Tel.: +90 212 482 91 06 or 07
Fax: +90 212 482 91 10

United Kingdom

Warwick
Tel: +44 (0)1926 317 878
Fax: +44 (0)1926 317 855

International

Australia

Castle Hill
Tel: +61 (0)2-9634 7777
Fax: +61 (0)2-9899 6184

Canada

Milton, Ontario
Tel: +1 905-693-3000
Fax: +1 905-876-0788

China

Beijing
Tel: +86 10 6561 0520
Fax: +86 10 6561 0526

Asia Pacific Group

Hong Kong, Kowloon
Tel: +852 2428 8008
Fax: +852 2425 6896

India

Mumbai
Tel: +91 22 7907081
Fax: +91 22 7907080

Japan

Tokyo
Tel: +(81) 3 6408 3900
Fax: +(81) 3 5449 7201

Latin America Group

Brazil
Tel: +55 12 3954-5100
Fax: +55 12 3954-5266

South Africa

Kempton Park
Tel: +27 (0)11-961 0700
Fax: +27 (0)11-392 7213

USA

Cleveland (industrial)
Tel: +1 216-896-3000
Fax: +1 216-896-4031
Lincolnshire (mobile)
Tel: +1 847-821-1500
Fax: +1 847-821-7600

Parker Hannifin is the world's premier supplier of motion and control systems and solutions, with sales and manufacturing facilities throughout the world. For product information and details of your nearest Parker sales office, visit us at www.parker.com or call free on 00800 2727 5374.



Catalogue HY17-8546/UK
PDF 12/04

© Copyright 2004
Parker Hannifin Corporation
All rights reserved.