

TITLE	DRAWING NUMBER	REVISION	STATUS	SHEET
SERVICE PARTS P3105 DESIGN SERIES II	P2-105-0404	A	PR	1 OF 7

DRAWN BY	DATE	CHANGED BY	DATE	ECN NUMBER
E. BOONE	15APR02	B. LARKIN	23MAY02	133522

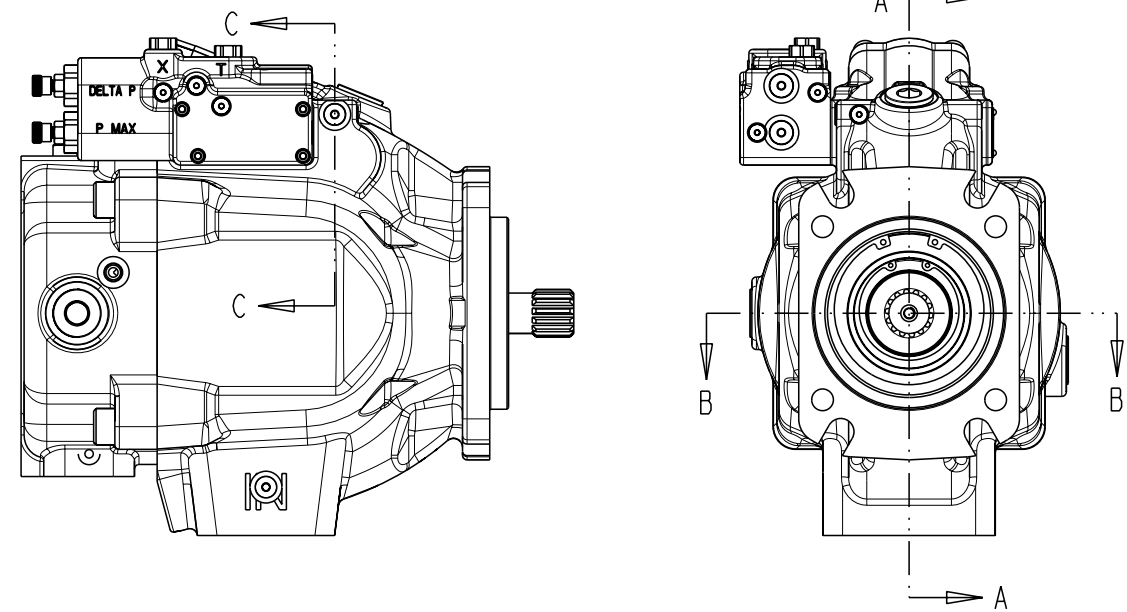

NOTES:
 1 PUMP SHOWN IS A RIGHT HAND (CW) ROTATION PUMP. LEFT HAND (CCW) ROTATION PUMPS
 HAVE OUTLET GAUGE PORT REVERSED.

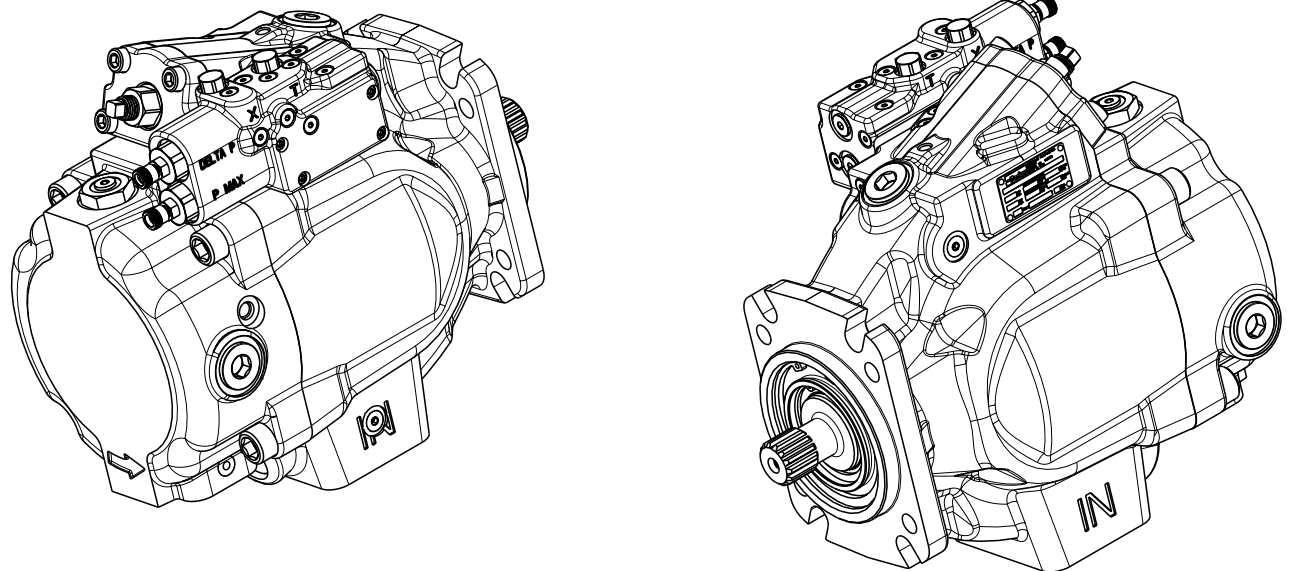
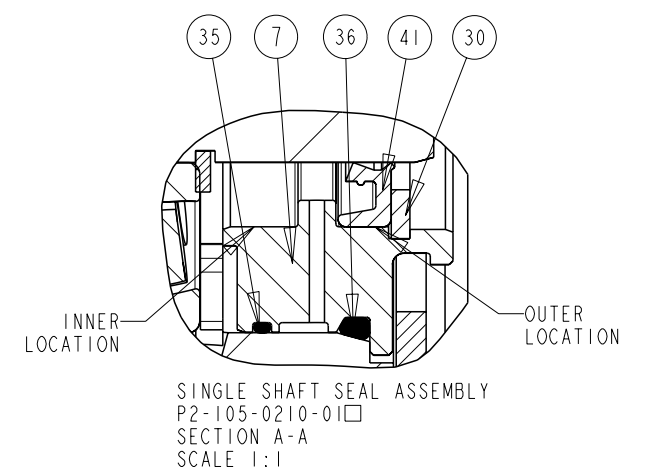
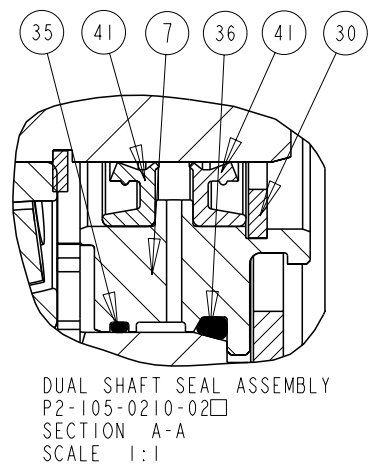
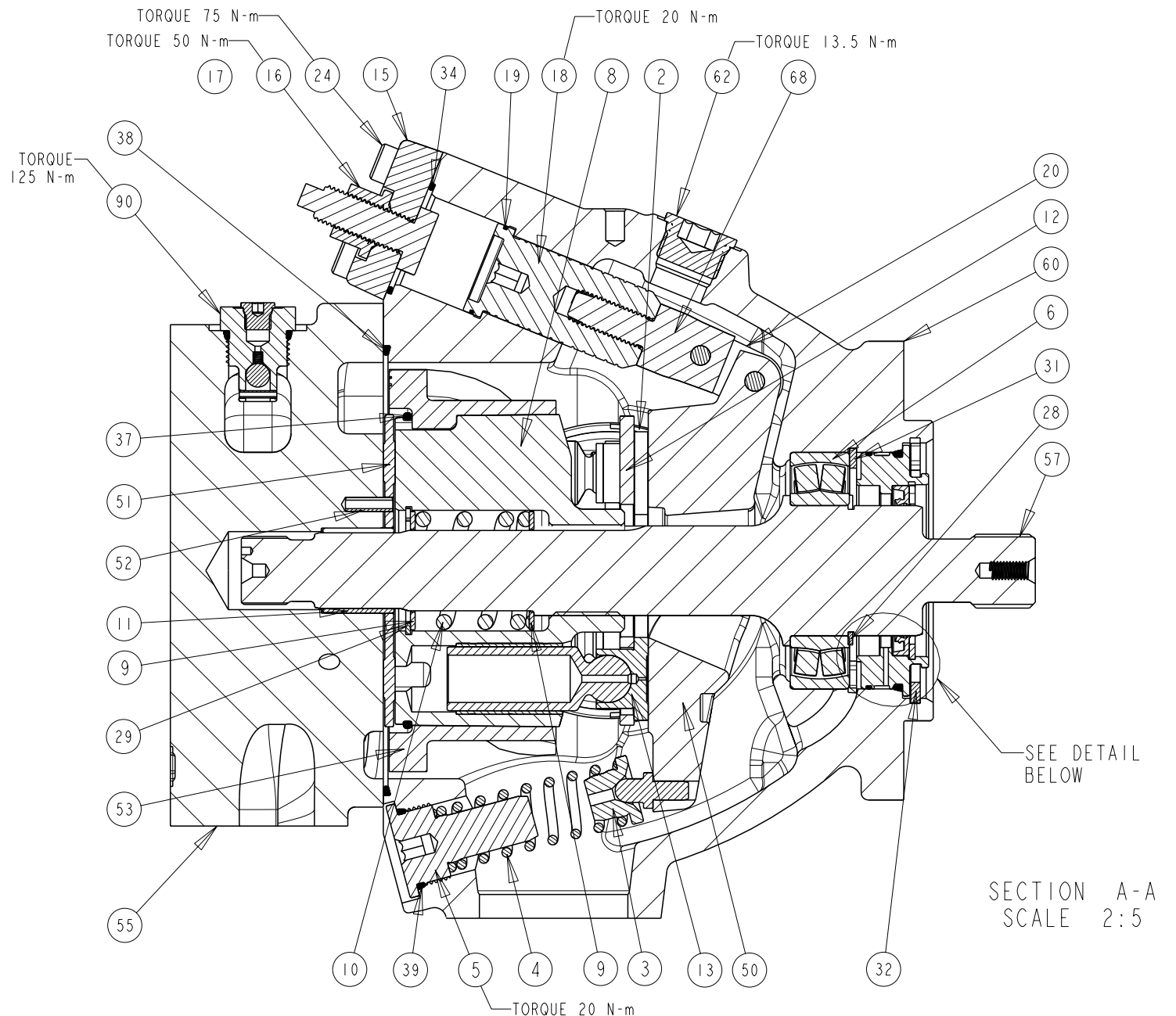

TITLE	DRAWING NUMBER	REVISION	STATUS	SHEET 2 OF 7
SERVICE PARTS P3105 DESIGN SERIES II	P2-105-0404	A	PR	

DRAWN BY	DATE	CHANGED BY	DATE	ECN NUMBER
E. BOONE	15APR02	B. LARKIN	23MAY02	133522

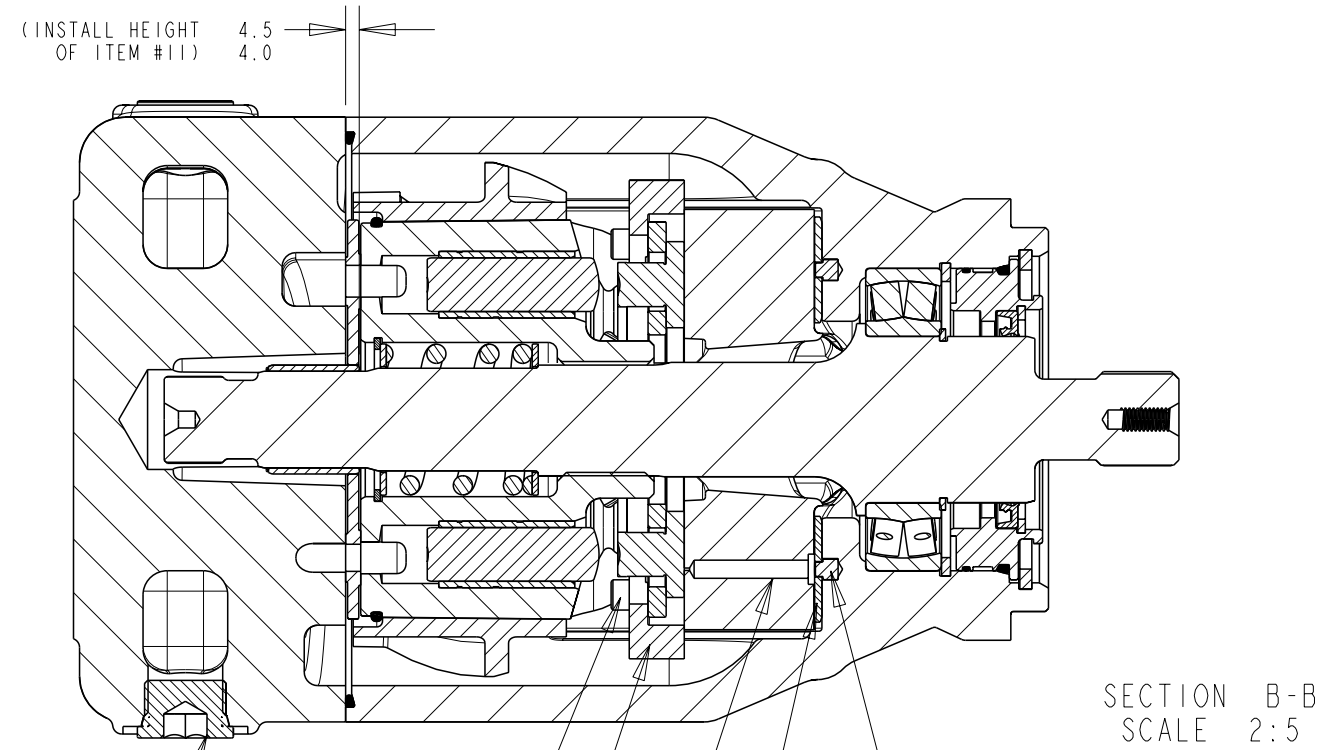

108X12 (SAE)
788516-12 (6149)
TORQUE 125 N-m

TORQUE 19 N-m

HOLE ON OPPOSITE SIDE OF SHAFT FOR LEFT HAND (CCW) MODELS

SECTION B-B
SCALE 2:5

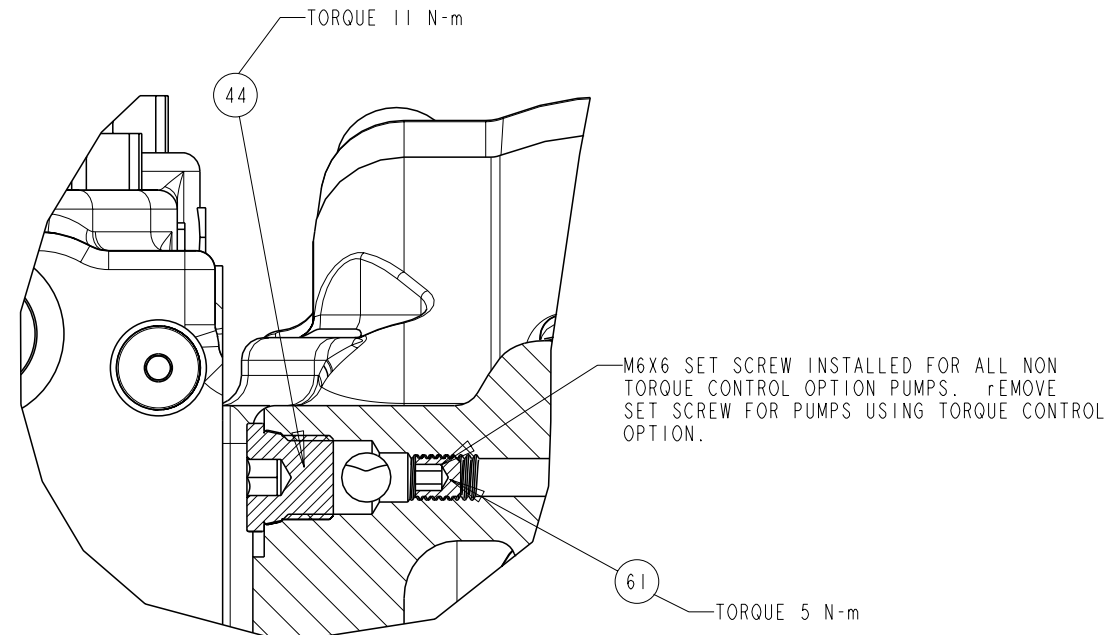

SECTION C-C
SCALE 1:1

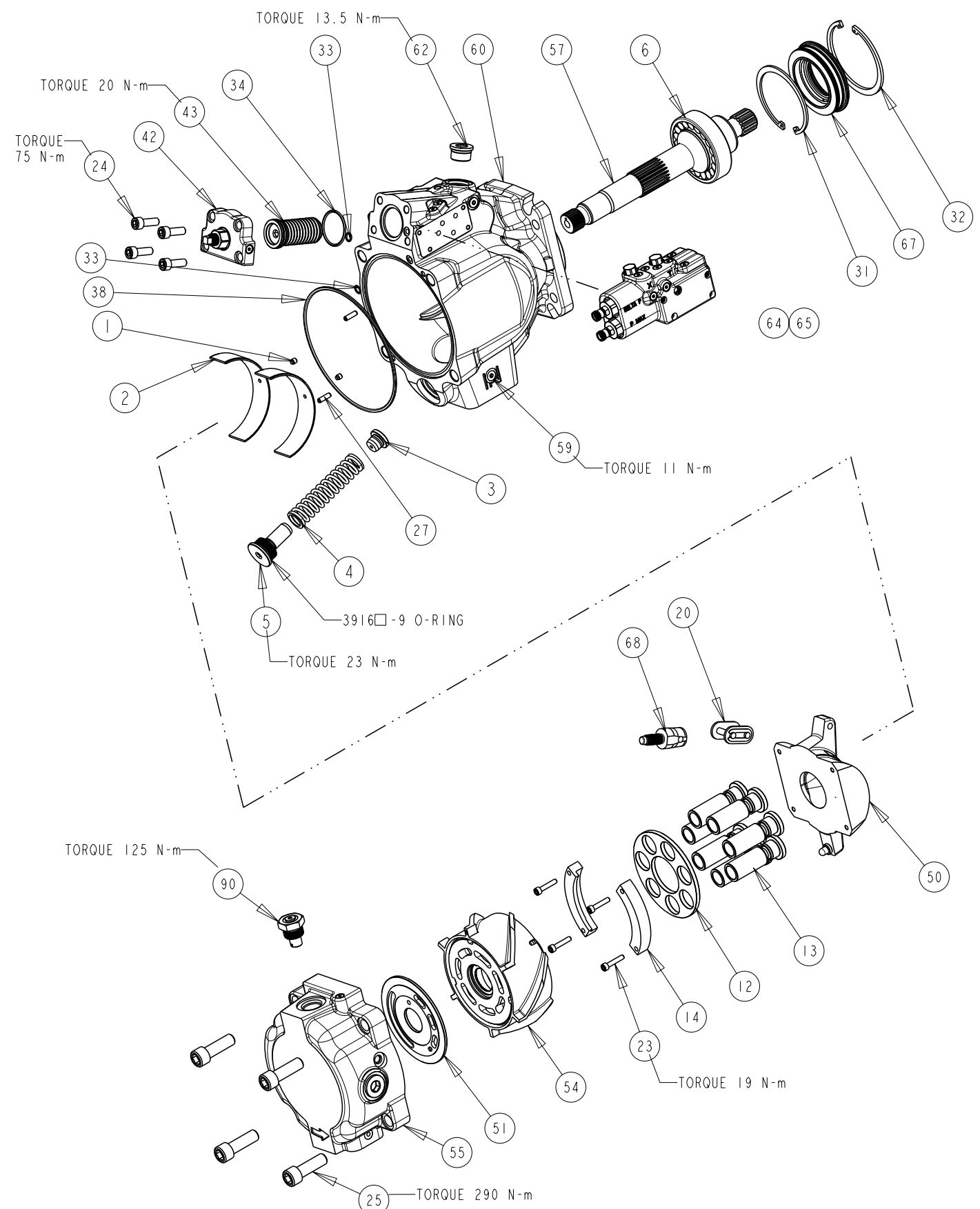

TITLE	DRAWING NUMBER	REVISION	STATUS	SHEET
SERVICE PARTS P3105 DESIGN SERIES II	P2-105-0404	A	PR	3 OF 7

COMPENSATOR KITS

SINGLE SPOOL OPTIONS - ITEM 64

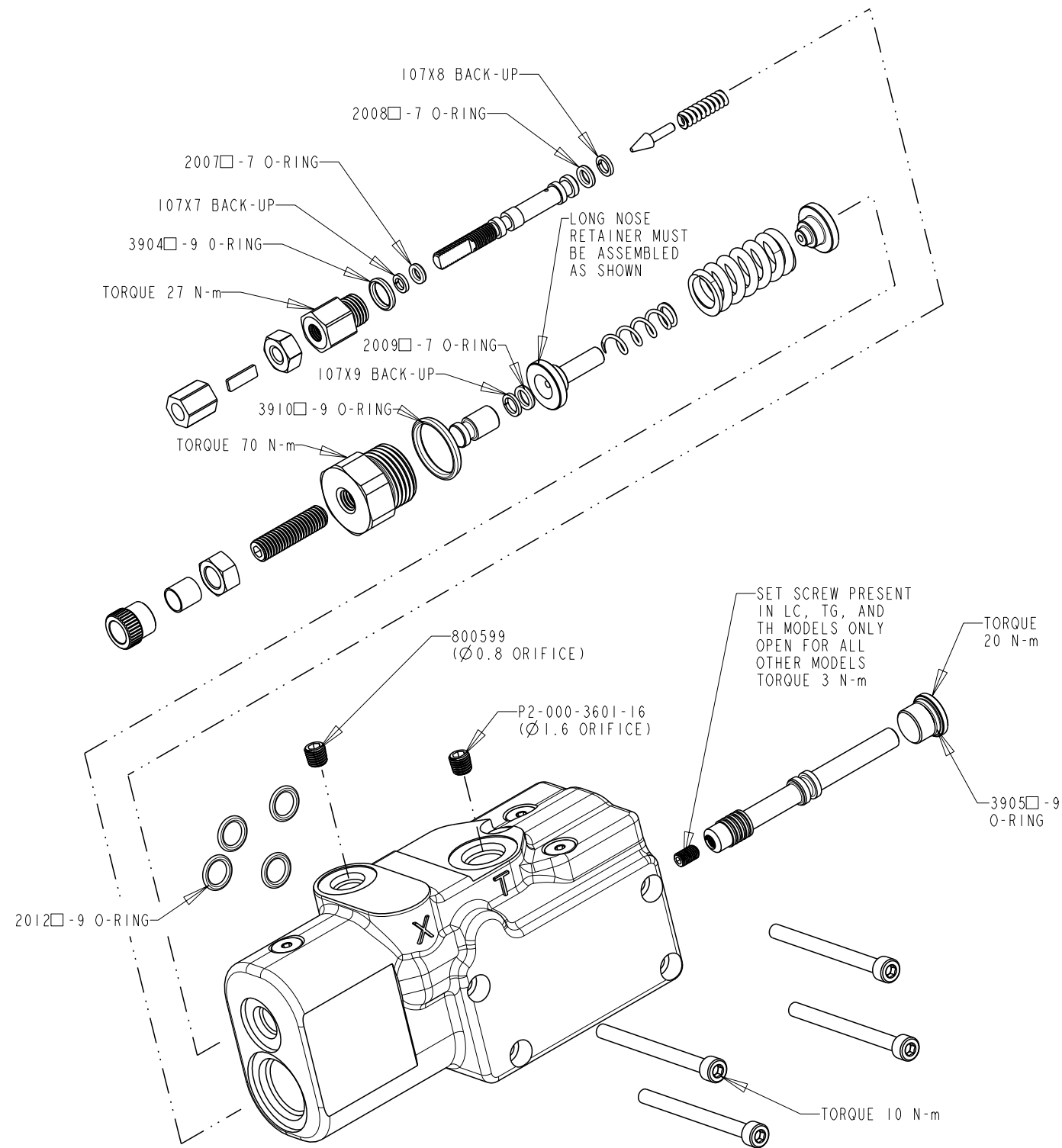

DRAWN BY	DATE	CHANGED BY	DATE	ECN NUMBER
E. BOONE	15APR02	B. LARKIN	23MAY02	133522

COMPENSATOR KITS

DUAL SPOOL OPTIONS - ITEM 65

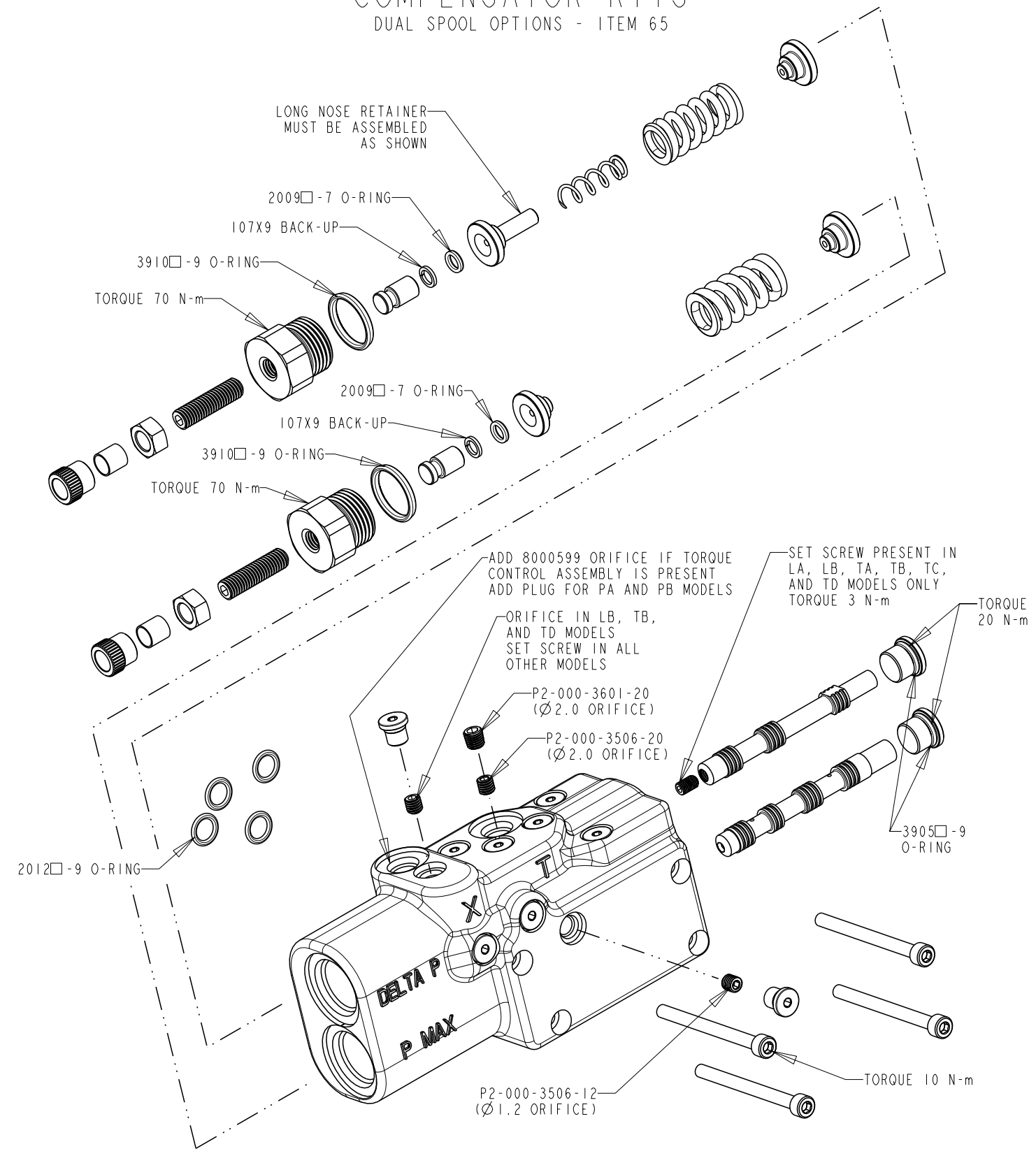

THRU DRIVE KITS

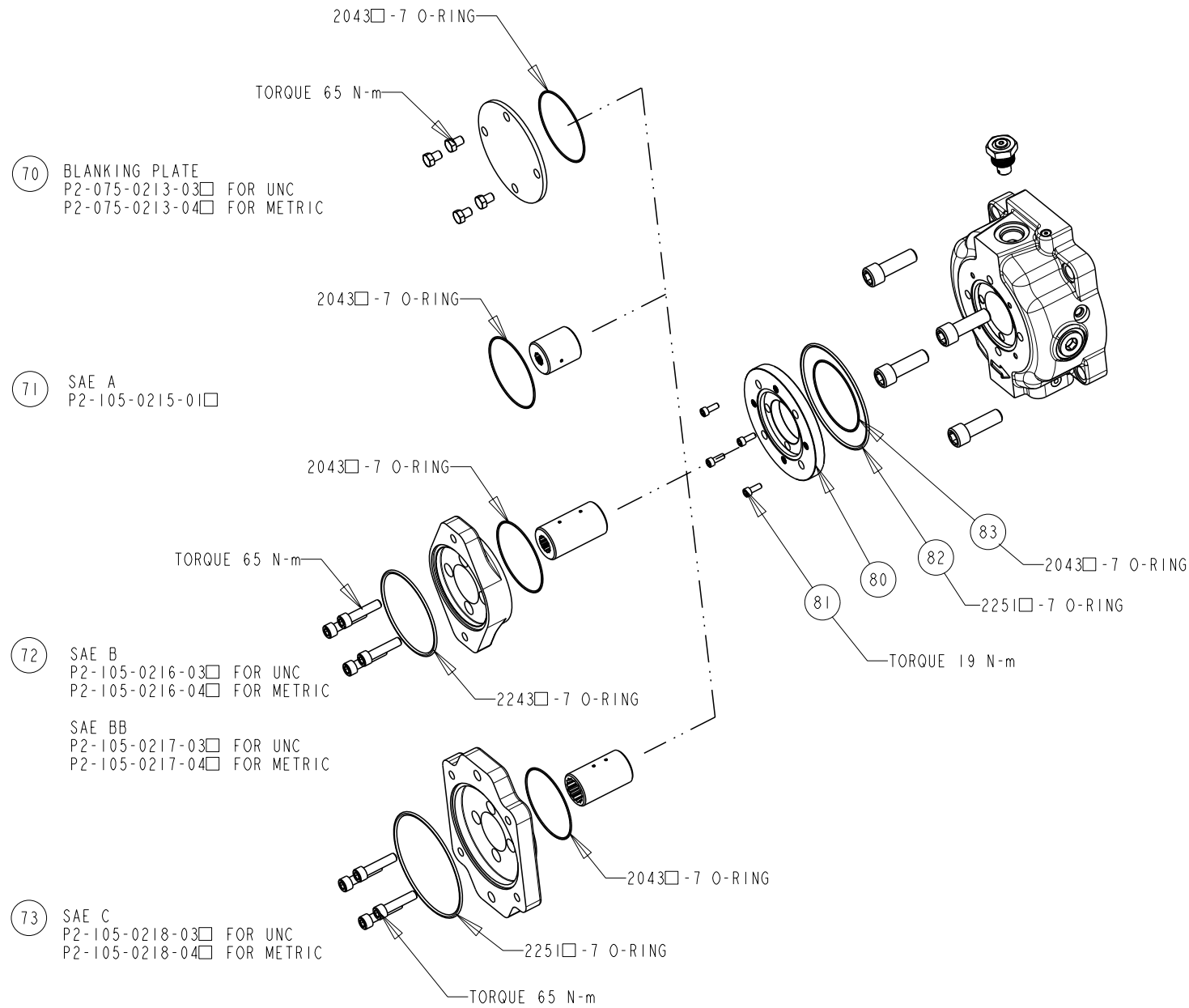

MAX VOLUME ASSEMBLY AND SERVO PISTON KIT

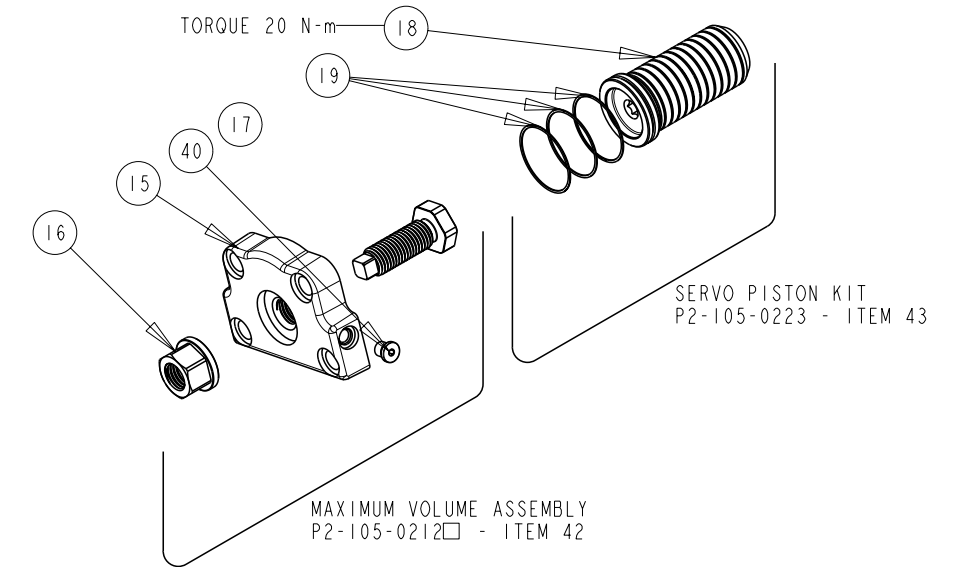

BARREL KIT AND ROTATION GROUP KIT

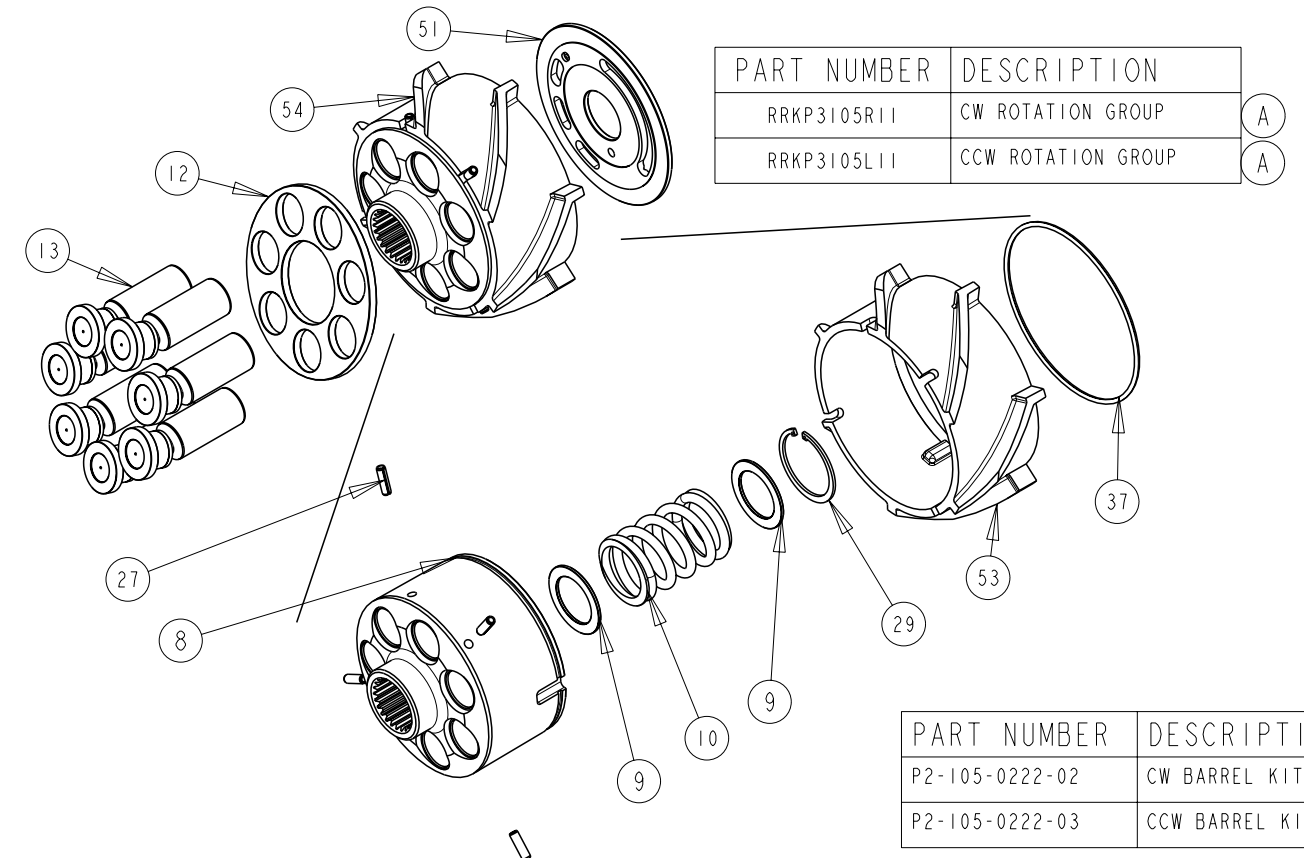

TITLE	DRAWING NUMBER	REVISION	STATUS	SHEET
SERVICE PARTS P3105 DESIGN SERIES II	P2-105-0404	A	PR	5 OF 7

SHAFT ASSEMBLY KITS ITEM 57

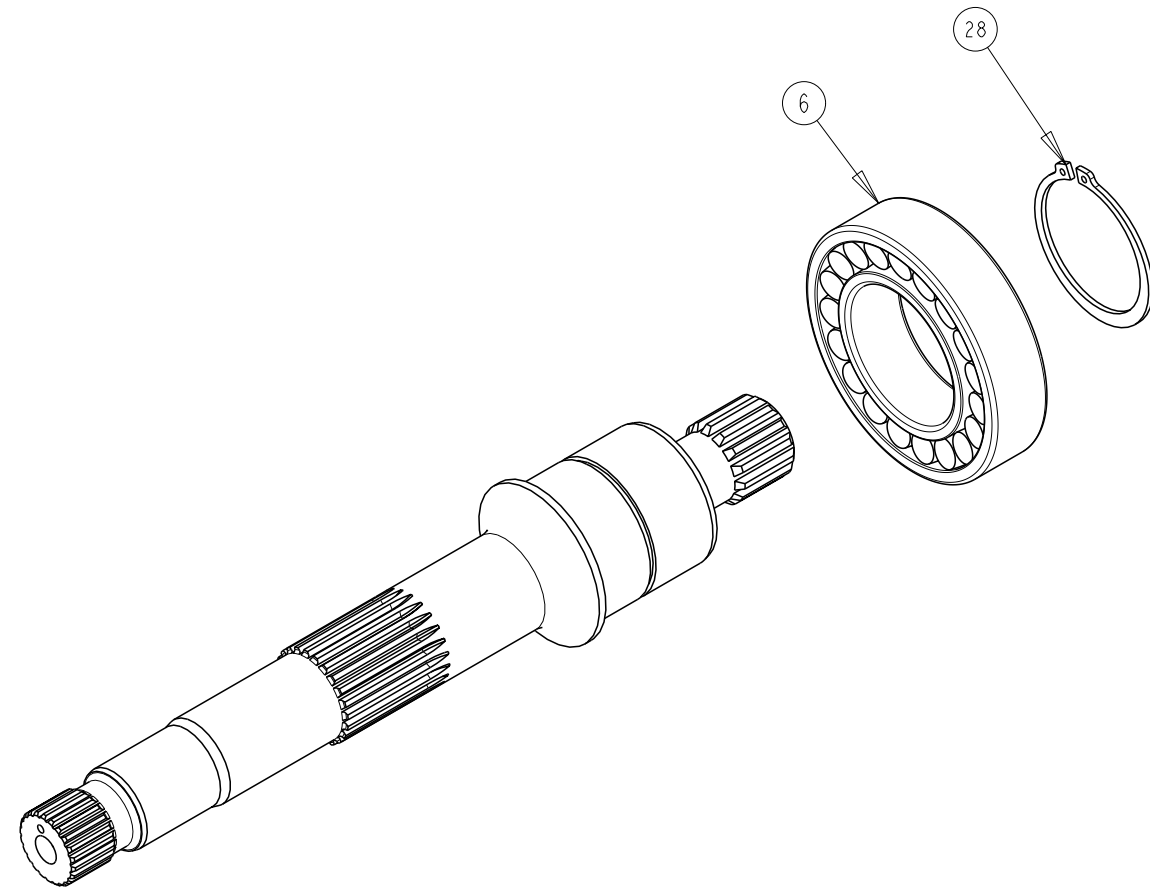

SHAFT ONLY	SHAFT ASSY	DESCRIPTION
P2-105-3525	P2-105-0225-36	C SPLINE THRU
P2-105-3519	P2-105-0225-40	D SPLINE THRU
P2-105-3533	P2-105-0225-46	C KEY THRU
P2-105-3535	P2-105-0225-48	CC KEY THRU
P2-105-3520	P2-105-0225-56	C SPLINE THRU NO UNDERCUT
P2-105-3546	P2-105-0225-60	D SPLINE THRU NO UNDERCUT

DRAWN BY	DATE	CHANGED BY	DATE	ECN NUMBER
E. BOONE	15APR02	B. LARKIN	23MAY02	133522

COVER ASSEMBLY KITS ITEM 55

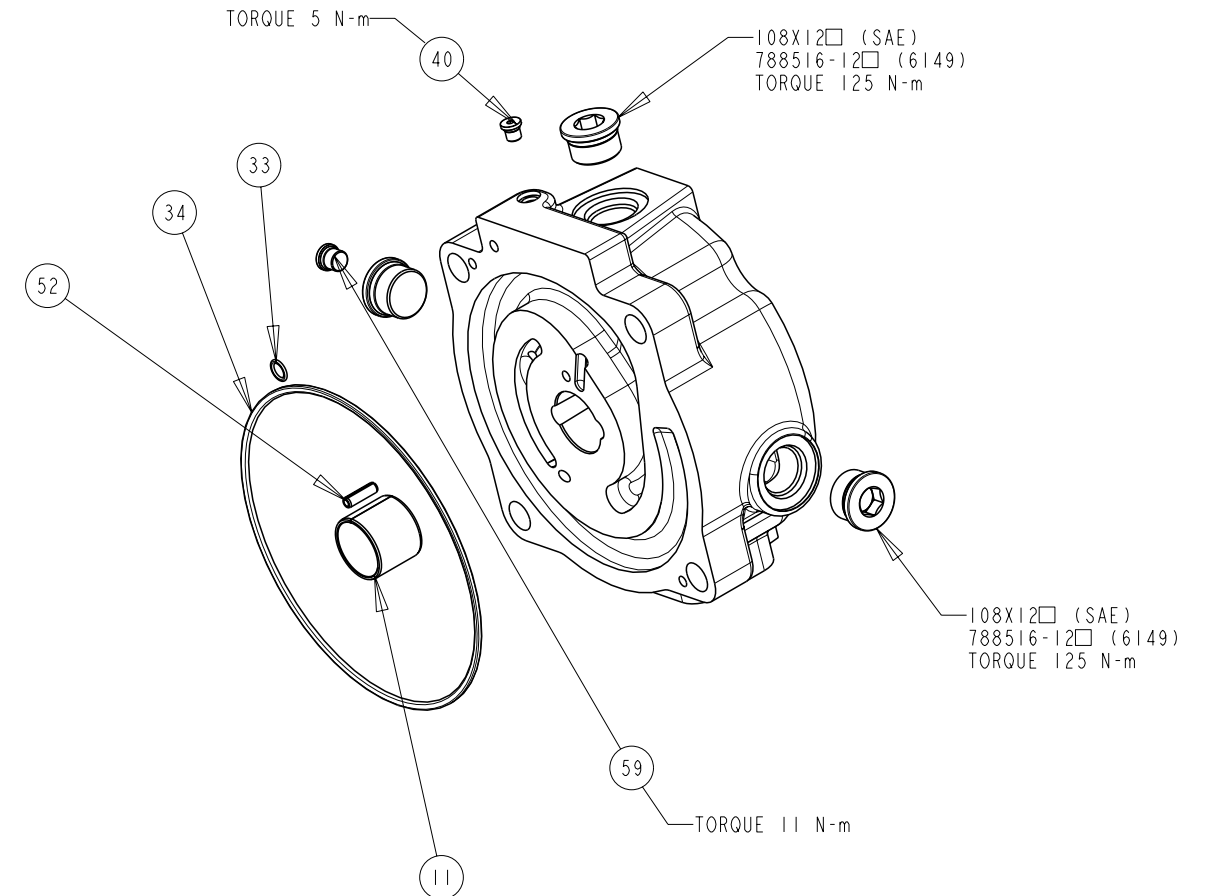

COVER ONLY	COVER ASSY	DESCRIPTION
P2-105-1015-01	P2-105-0226-09□	SIDE PORT, CCW, UNC
P2-105-1015-02	P2-105-0226-10□	SIDE PORT, CCW, UNC, THRU
P2-105-1015-03	P2-105-0226-11□	SIDE PORT, CCW, METRIC
P2-105-1015-04	P2-105-0226-12□	SIDE PORT, CCW, METRIC, THRU
P2-105-1016-01	P2-105-0226-13□	SIDE PORT, CW, UNC
P2-105-1016-02	P2-105-0226-14□	SIDE PORT, CW, UNC, THRU
P2-105-1016-03	P2-105-0226-15□	SIDE PORT, CW, METRIC
P2-105-1016-04	P2-105-0226-16□	SIDE PORT, CW, METRIC, THRU

TITLE	DRAWING NUMBER	REVISION	STATUS	SHEET
SERVICE PARTS P3105 DESIGN SERIES II	P2-105-0404	A	PR	6 OF 7

DRAWN BY	DATE	CHANGED BY	DATE	ECN NUMBER
E. BOONE	15APR02	B. LARKIN	23MAY02	133522

TORQUE CONTROL CARTRIDGE

P2-000-0803 □ - ITEM 63 (A)

ASSEMBLY, DIS-ASSEMBLY AND REPAIR NOTES

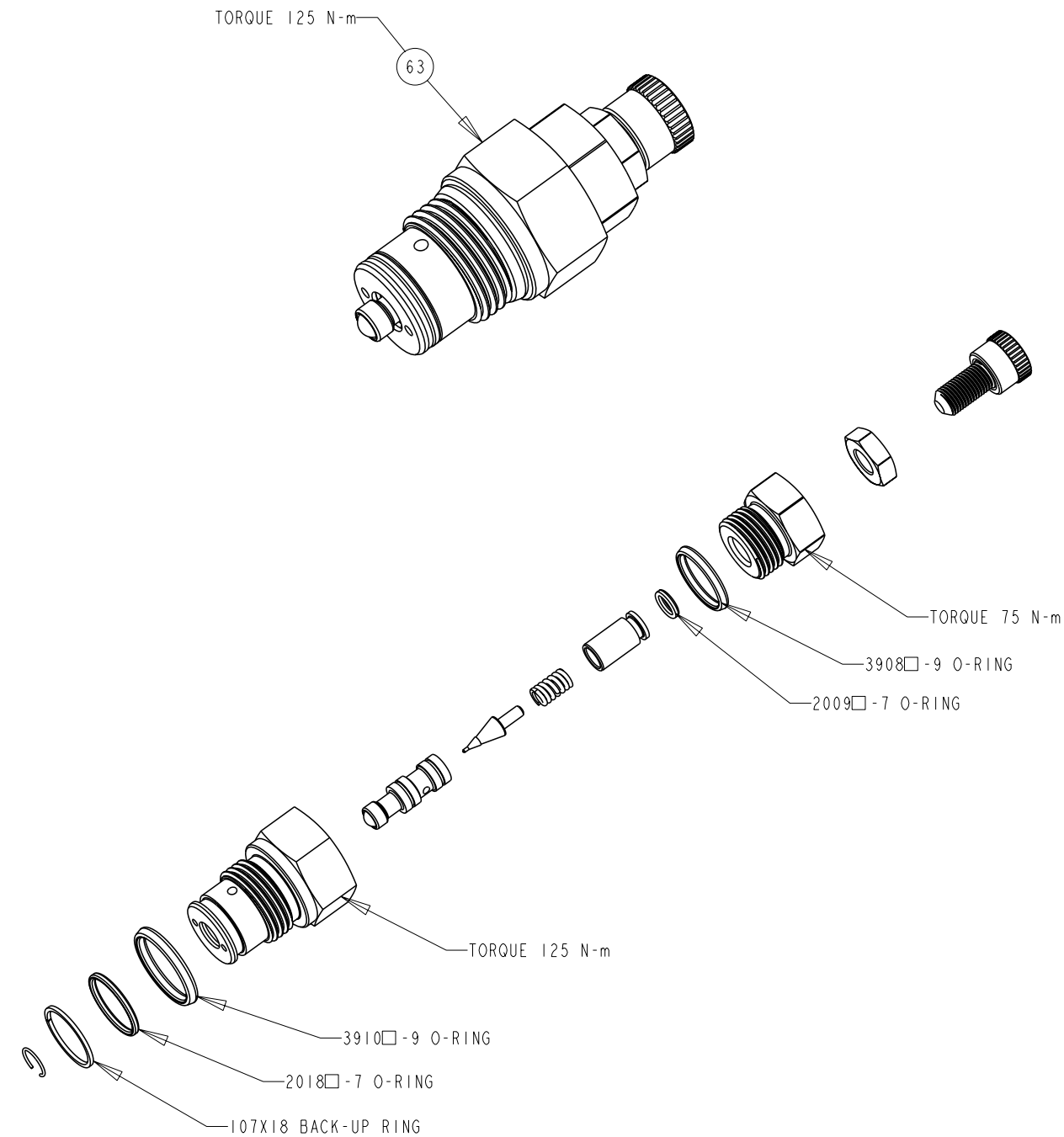

DISASSEMBLY STEPS FOR ENTIRE PUMP

1. REMOVE COVER SCREWS AND COVER
2. REMOVE IMPELLER
3. DE-STROKE PUMP TO MINIMUM ANGLE WITH MAX VOLUME SCREW
4. REMOVE FIXED CLEARANCE HOLD DOWN SCREWS AND HOLD DOWN PARTS
5. REMOVE ROTATING GROUP (BARREL, SLIPPER RETAINER AND PISTONS)
6. REMOVE SHAFT SEAL CARRIER
7. REMOVE SHAFT
8. REMOVE BIAS SPRING PLUG, SPRING AND RETAINER
9. REMOVE MAX. VOLUME ASSY
10. REMOVE SERVO PISTON ASSY.
11. REMOVE SWASHPLATE ASSEMBLY

SHAFT SEAL REPLACEMENT

1. REMOVE SEAL CARRIER ONLY
2. REMOVE OLD SEAL
3. INSPECT SHAFT
4. IF SHAFT IS WORN INSTALL NEW SEAL IN INNER LOCATION FOR SINGLE SEAL APPLICATIONS (SEE SHEET 1).
REPLACE SHAFT FOR DUAL SEAL APPLICATIONS

