

NOTES:  
 1 PUMP SHOWN IS A RIGHT HAND (CW) ROTATION PUMP. LEFT HAND (CCW) ROTATION PUMPS HAVE OUTLET GAUGE PORT REVERSED.

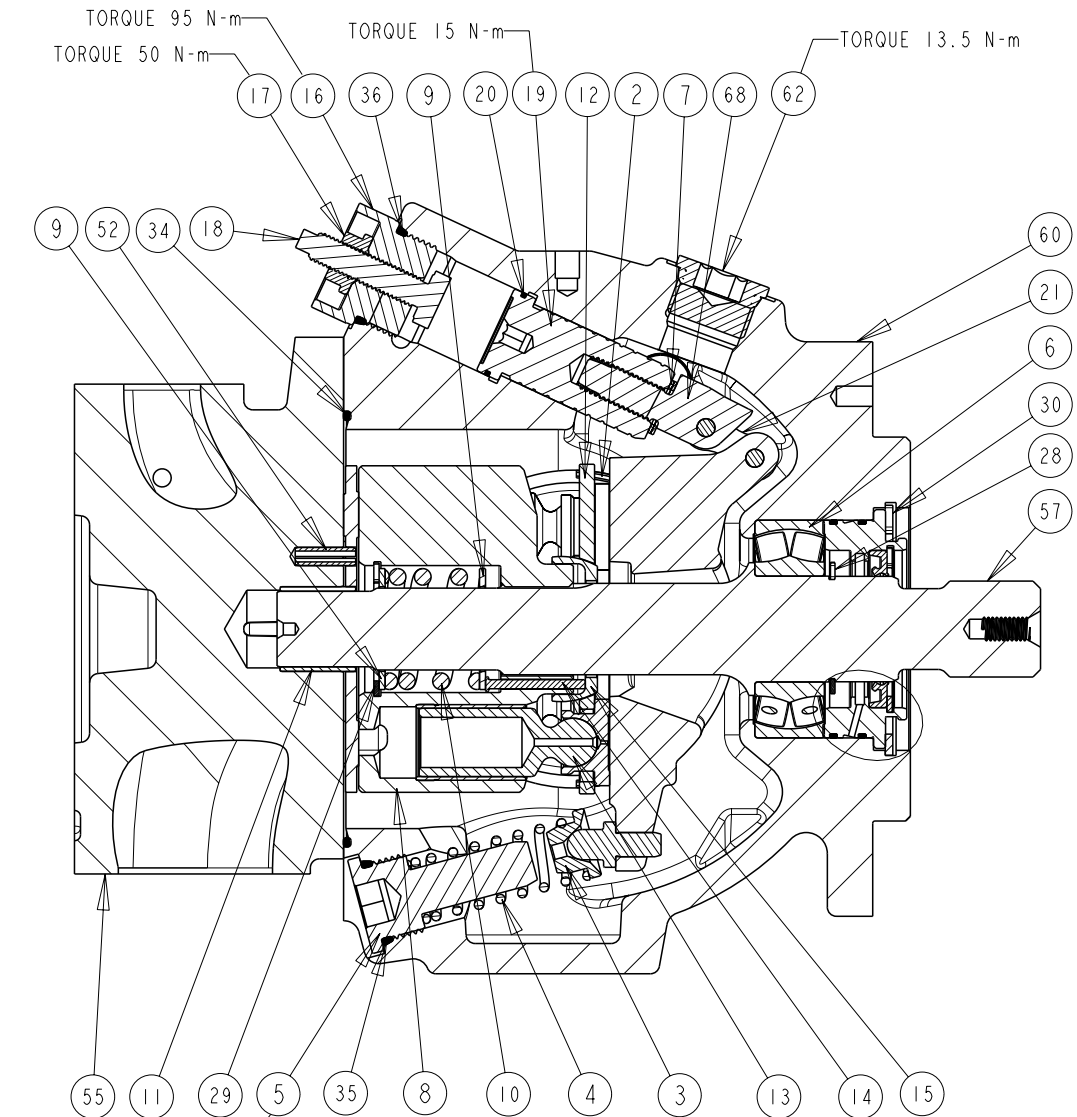

SECTION A-A  
 SCALE 2:5

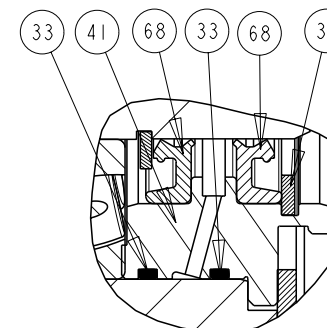

DUAL SHAFT SEAL ASSEMBLY  
 P2-060-0210-02□  
 SECTION A-A  
 SCALE 1:1

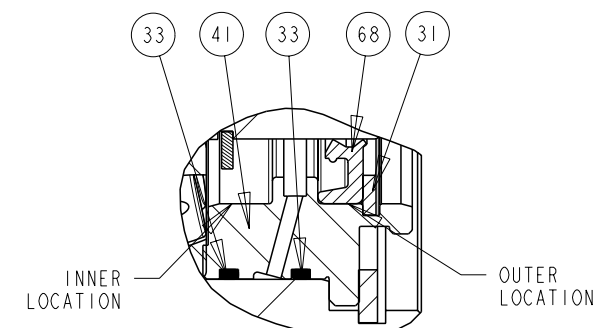

SINGLE SHAFT SEAL ASSEMBLY  
 P2-060-0210-01□  
 SECTION A-A  
 SCALE 1:1

TITLE	DRAWING NUMBER	REVISION	STATUS	SHEET
SERVICE PARTS P2060 DESIGN SERIES II	P2-060-0403	NONE	PR	2 OF 7

DRAWN BY	DATE	CHANGED BY	DATE	ECN NUMBER
E. BOONE	15APR02	B. LARKIN	20MAY02	133522

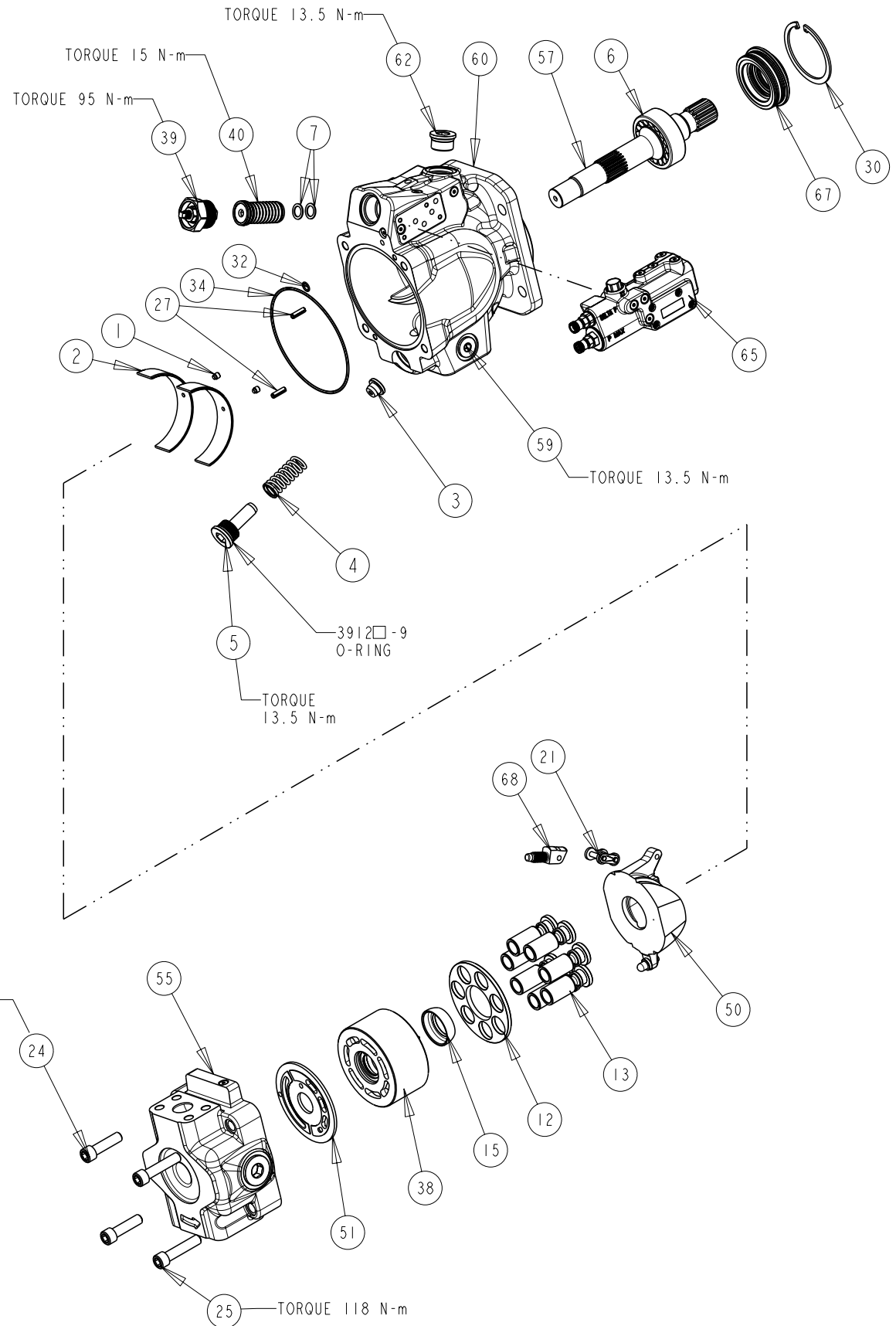
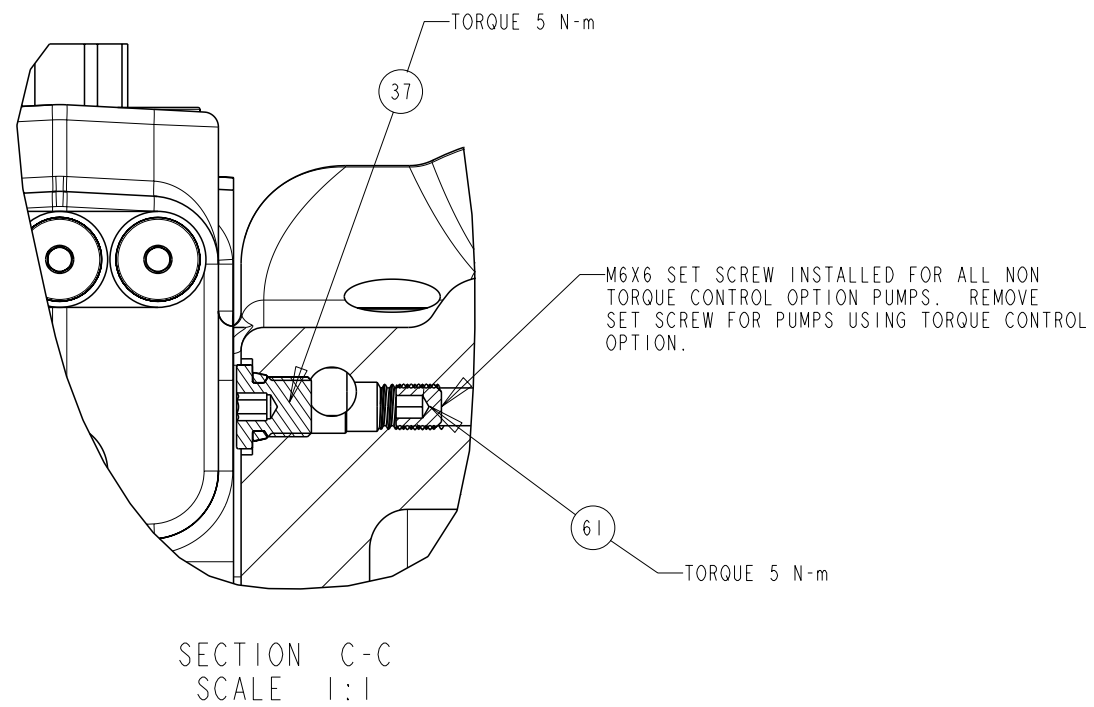
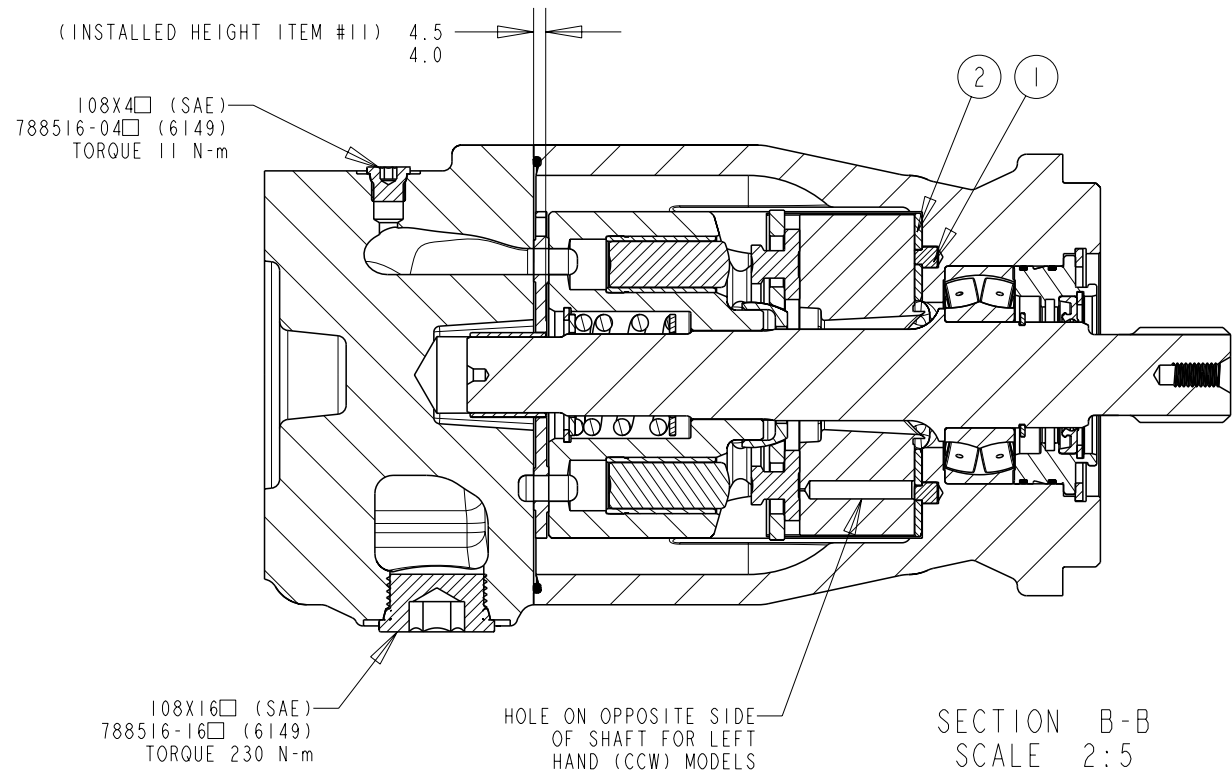

TITLE	DRAWING NUMBER	REVISION	STATUS	SHEET
SERVICE PARTS P2060 DESIGN SERIES II	P2-060-0403	A	PR	3 OF 7

DRAWN BY	DATE	CHANGED BY	DATE	ECN NUMBER
E. BOONE	15APR02	B. LARKIN	20MAY02	133522

## COMPENSATOR KITS ITEM 65

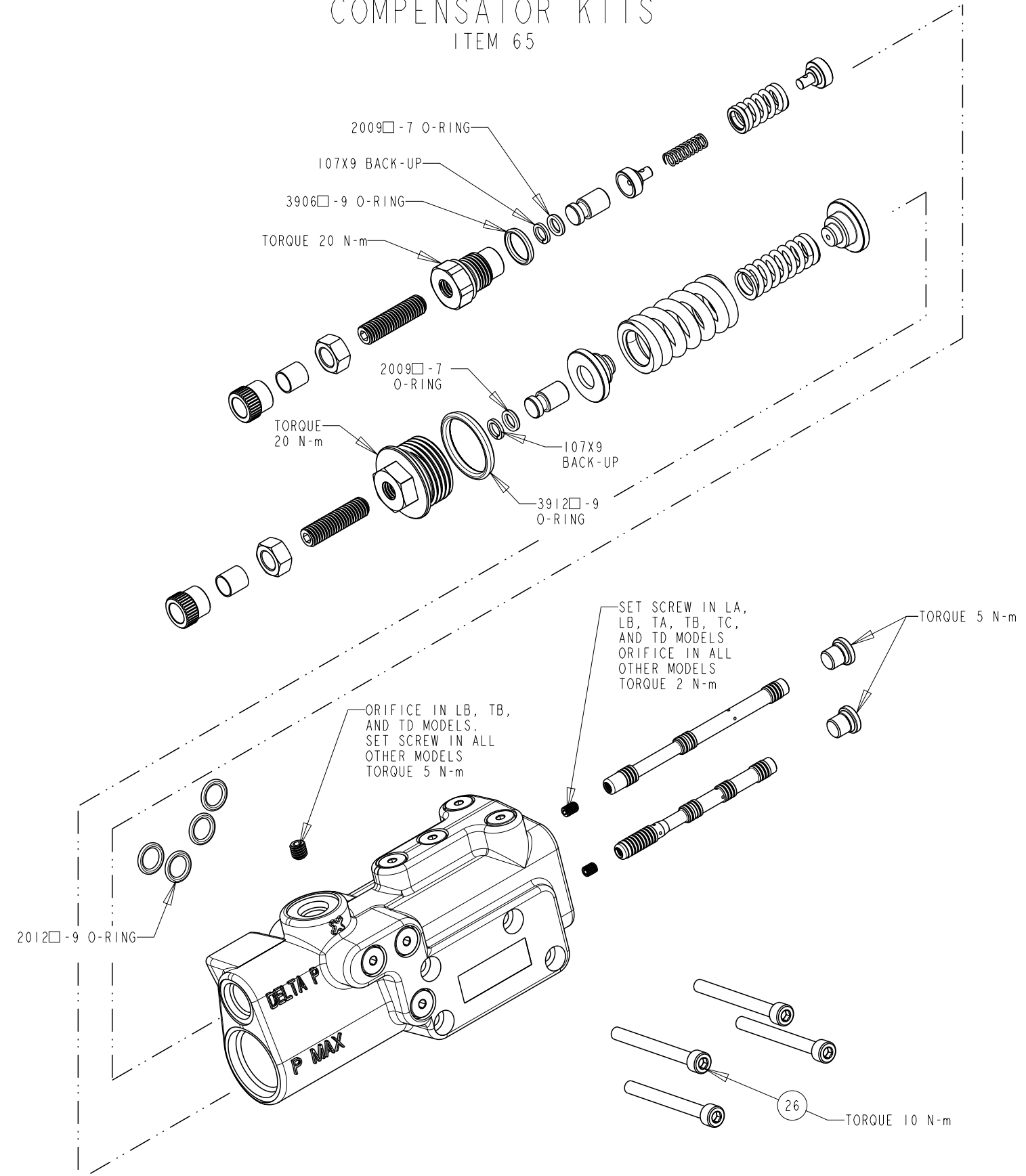

### THRU DRIVE KITS

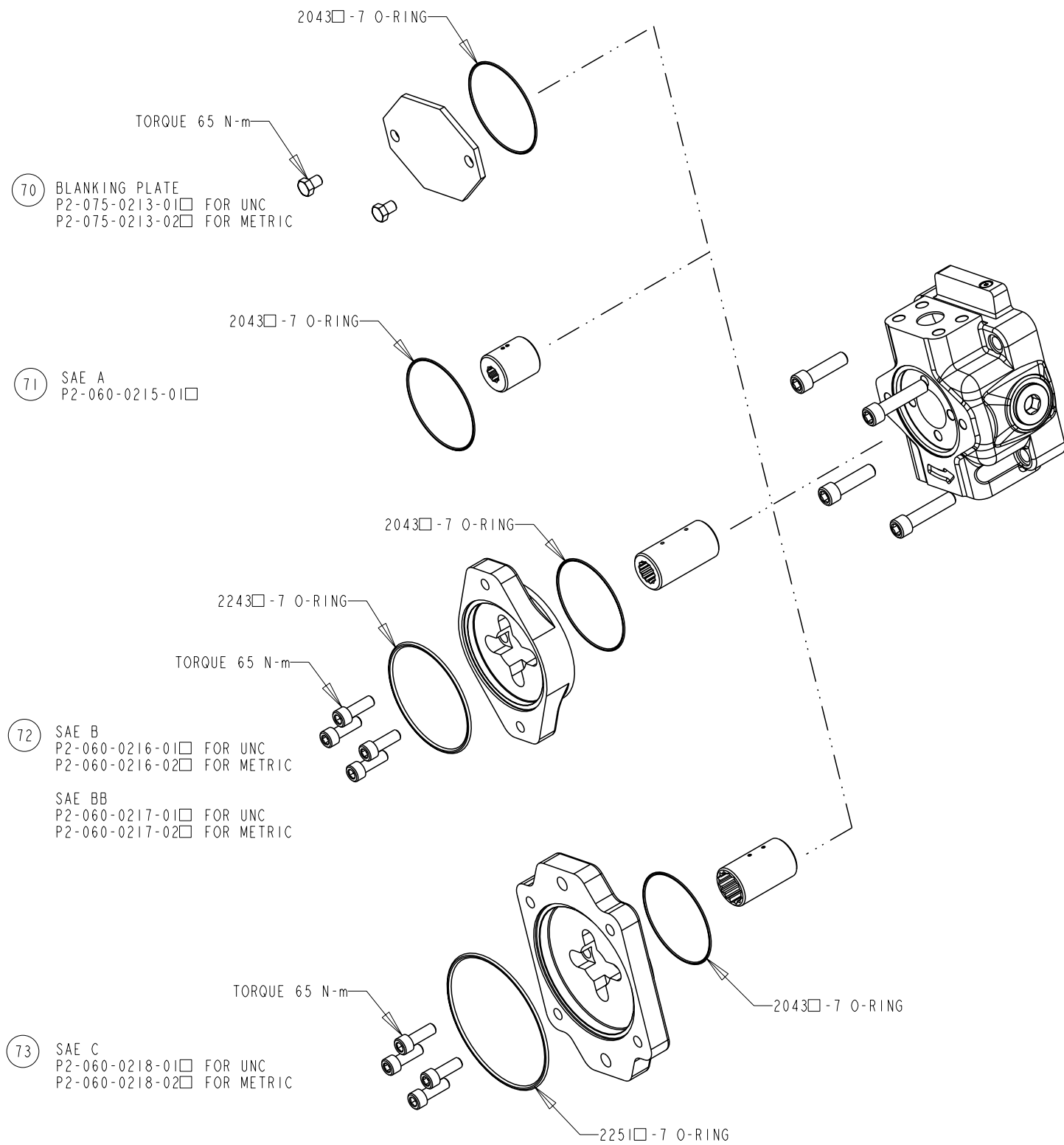

### MAX VOLUME ASSEMBLY SERVO PISTON KIT

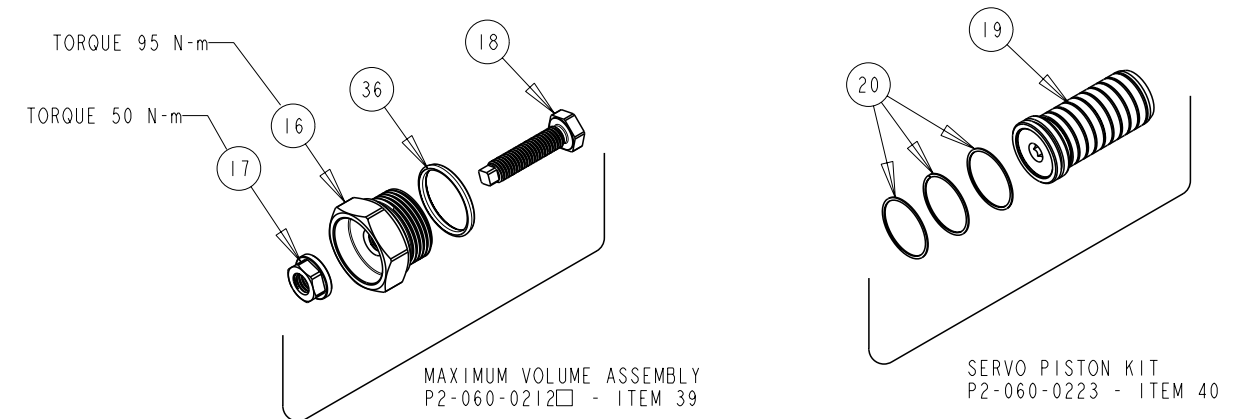

### BARREL KIT AND ROTATION GROUP KIT

PART NUMBER	DESCRIPTION	
RRKP2060R11	CW ROTATION GROUP	A
RRKP2060L11	CCW ROTATION GROUP	A

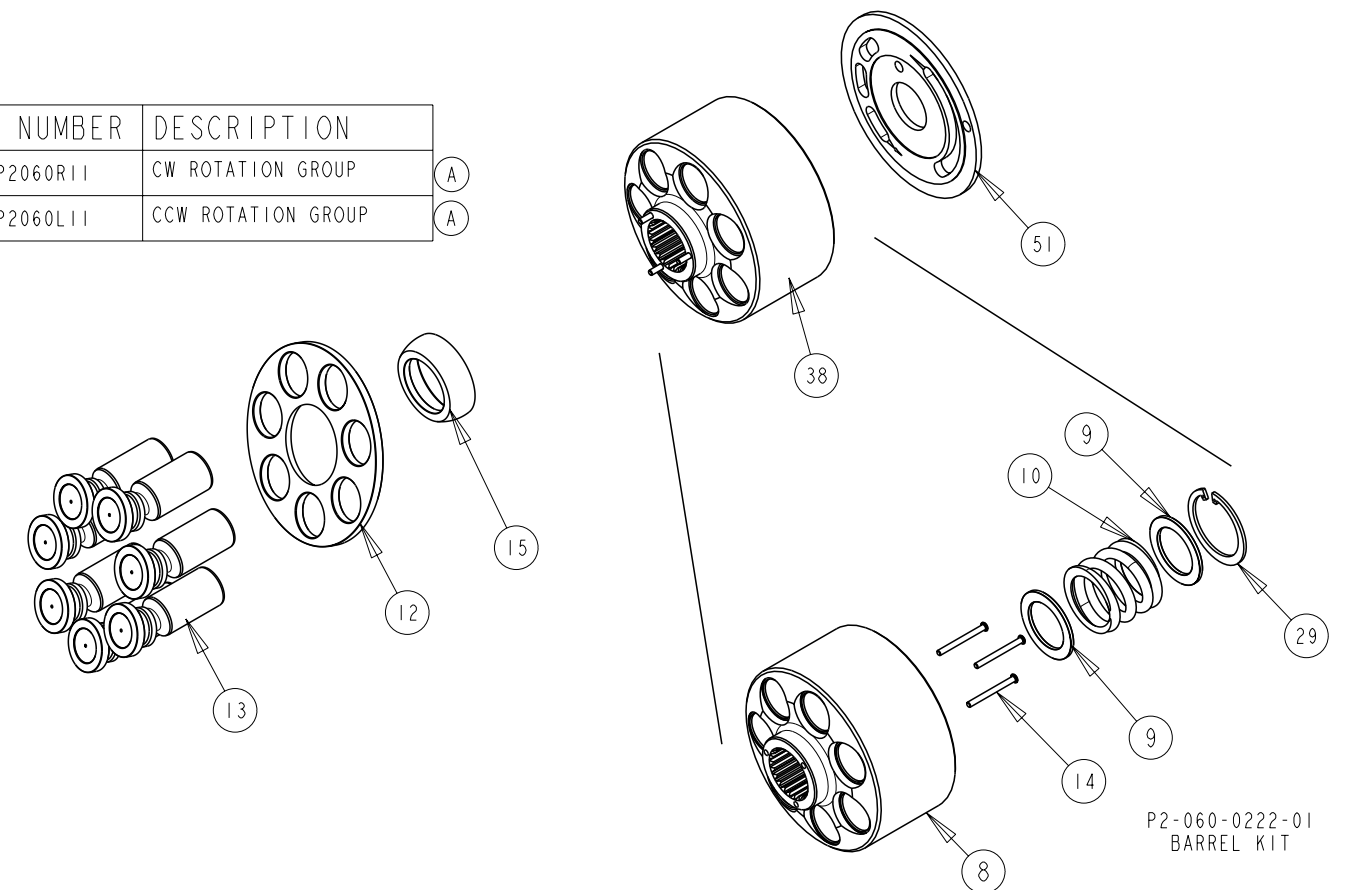

TITLE	DRAWING NUMBER	REVISION	STATUS	SHEET
SERVICE PARTS P2060 DESIGN SERIES II	P2-060-0403	A	PR	5 OF 7

## SHAFT ASSEMBLY KITS ITEM 57

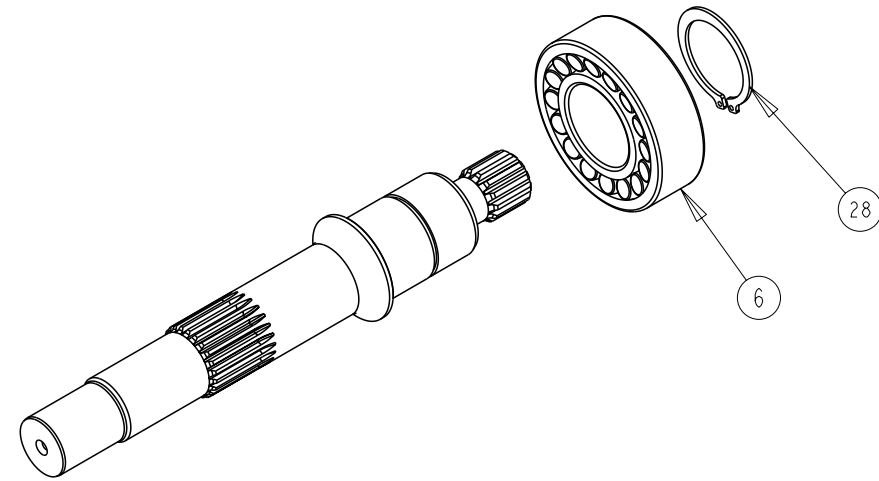

SHAFT ASSEMBLY INCLUDES SHAFT, BEARING, AND SNAP RING

SHAFT ONLY	SHAFT ASSY	DESCRIPTION
P2-060-3521	P2-060-0225-31	B SPLINE
P2-060-3522	P2-060-0225-32	B SPLINE THRU
P2-060-3523	P2-060-0225-33	BB SPLINE
P2-060-3524	P2-060-0225-34	BB SPLINE THRU
P2-060-3512	P2-060-0225-35	C SPLINE
P2-060-3525	P2-060-0225-36	C SPLINE THRU
P2-060-3528	P2-060-0225-41	B KEY
P2-060-3529	P2-060-0225-42	B KEY THRU
P2-060-3530	P2-060-0225-43	BB KEY
P2-060-3531	P2-060-0225-44	BB KEY THRU
P2-060-3532	P2-060-0225-45	C KEY
P2-060-3533	P2-060-0225-46	C KEY THRU
P2-060-3538	P2-060-0225-51	B SPLINE NO UNDERCUT
P2-060-3539	P2-060-0225-52	B SPLINE THRU NO UNDERCUT
P2-060-3540	P2-060-0225-53	BB SPLINE NO UNDERCUT
P2-060-3541	P2-060-0225-54	BB SPLINE THRU NO UNDERCUT
P2-060-3542	P2-060-0225-55	C SPLINE NO UNDERCUT
P2-060-3520	P2-060-0225-56	C SPLINE THRU NO UNDERCUT

DRAWN BY	DATE	CHANGED BY	DATE	ECN NUMBER
E. BOONE	15APR02	B. LARKIN	20MAY02	133522

## COVER ASSEMBLY KITS ITEM 55

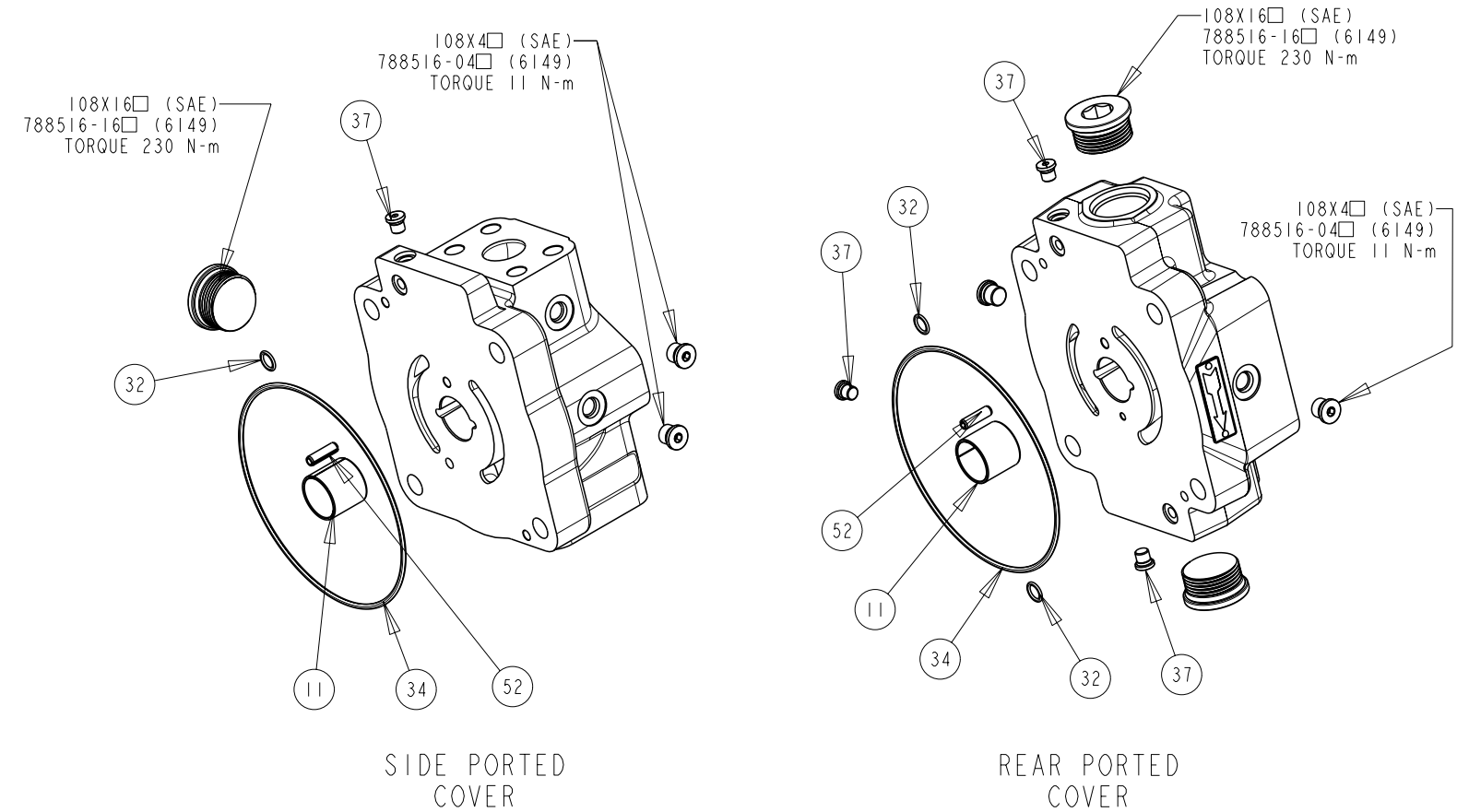

COVER ONLY	COVER ASSY	DESCRIPTION
P2-060-1013-01	P2-060-0226-01	SIDE PORTS, CCW, UNC
P2-060-1013-02	P2-060-0226-02	SIDE PORTS, CCW, UNC, THRU
P2-060-1013-03	P2-060-0226-03	SIDE PORTS, CCW, METRIC
P2-060-1013-04	P2-060-0226-04	SIDE PORTS, CCW, METRIC, THRU
P2-060-1014-01	P2-060-0226-05	SIDE PORTS, CW, UNC
P2-060-1014-02	P2-060-0226-06	SIDE PORTS, CW, UNC, THRU
P2-060-1014-03	P2-060-0226-07	SIDE PORTS, CW, METRIC
P2-060-1014-04	P2-060-0226-08	SIDE PORTS, CW, METRIC, THRU
P2-060-1017-01	P2-060-0226-17	REAR PORTS, CW, UNC
P2-060-1017-02	P2-060-0226-18	REAR PORTS, CW, METRIC
P2-060-1017-01	P2-060-0226-19	REAR PORTS, CCW, UNC
P2-060-1017-02	P2-060-0226-20	REAR PORTS, CCW, METRIC

TITLE	DRAWING NUMBER	REVISION	STATUS	SHEET
SERVICE PARTS P2060 DESIGN SERIES II	P2-060-0403	A	PR	6 OF 7

DRAWN BY	DATE	CHANGED BY	DATE	ECN NUMBER
E. BOONE	15APR02	B. LARKIN	20MAY02	133522

## TORQUE CONTROL CARTRIDGE

P2-000-0803 □ - ITEM 63

(A)

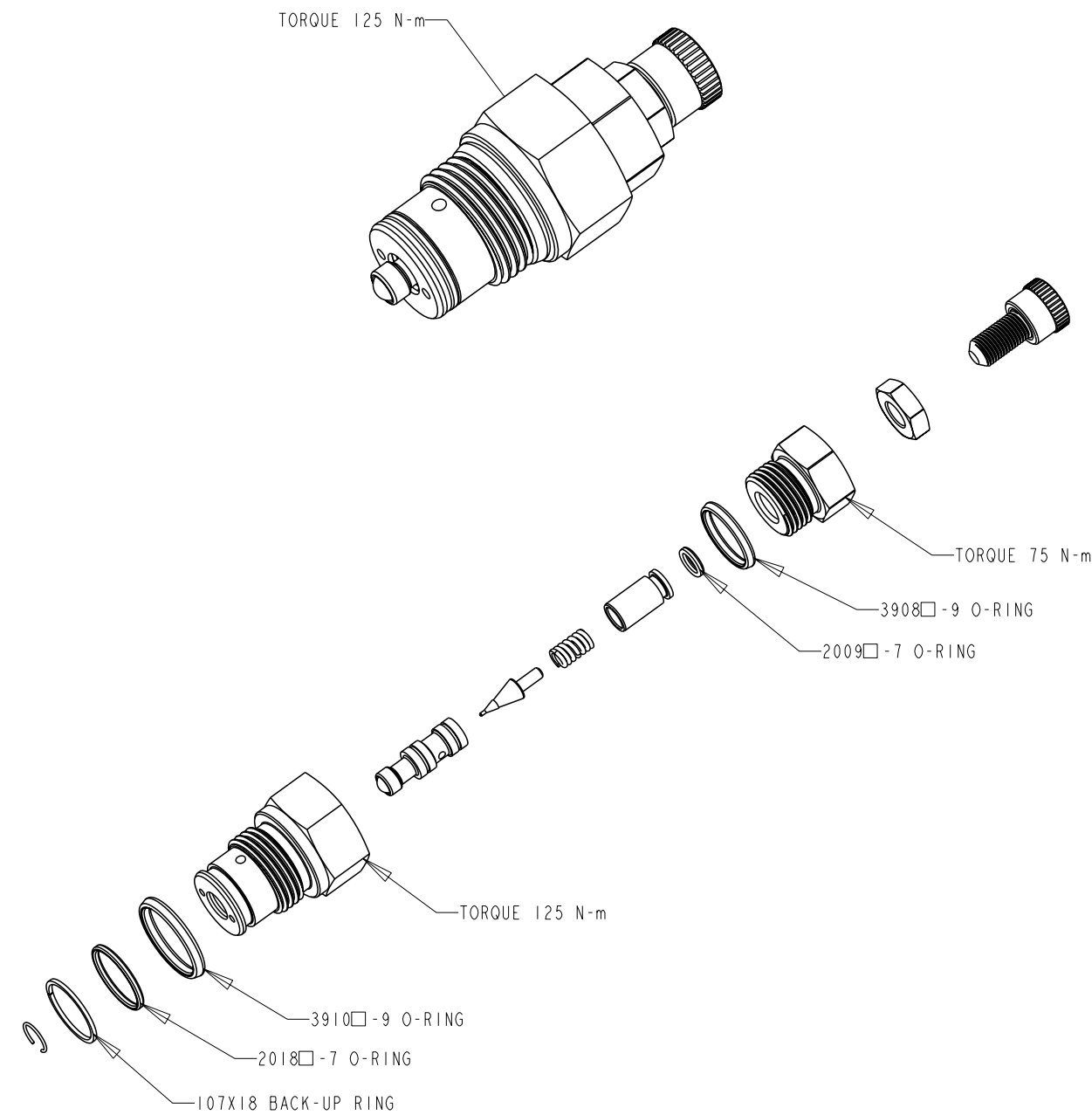

## ASSEMBLY, DIS-ASSEMBLY AND REPAIR NOTES

### DISASSEMBLY STEPS FOR ENTIRE PUMP

1. REMOVE COVER SCREWS AND COVER
2. REMOVE ROTATING GROUP
3. REMOVE SHAFT SEAL CARRIER
4. REMOVE SHAFT
5. REMOVE BIAS SPRING PLUG, SPRING AND RETAINER
6. REMOVE MAX. VOLUME ASSY
7. REMOVE SERVO PISTON ASSY
8. REMOVE SWASHPLATE ASSEMBLY

### SHAFT SEAL REPLACEMENT

1. REMOVE SEAL CARRIER ONLY
2. REMOVE OLD SEAL
3. INSPECT SHAFT
4. IF SHAFT IS WORN INSTALL NEW SEAL IN INNER LOCATION FOR SINGLE SEAL APPLICATIONS (SEE SHEET 1).  
REPLACE SHAFT FOR DUAL SEAL APPLICATIONS

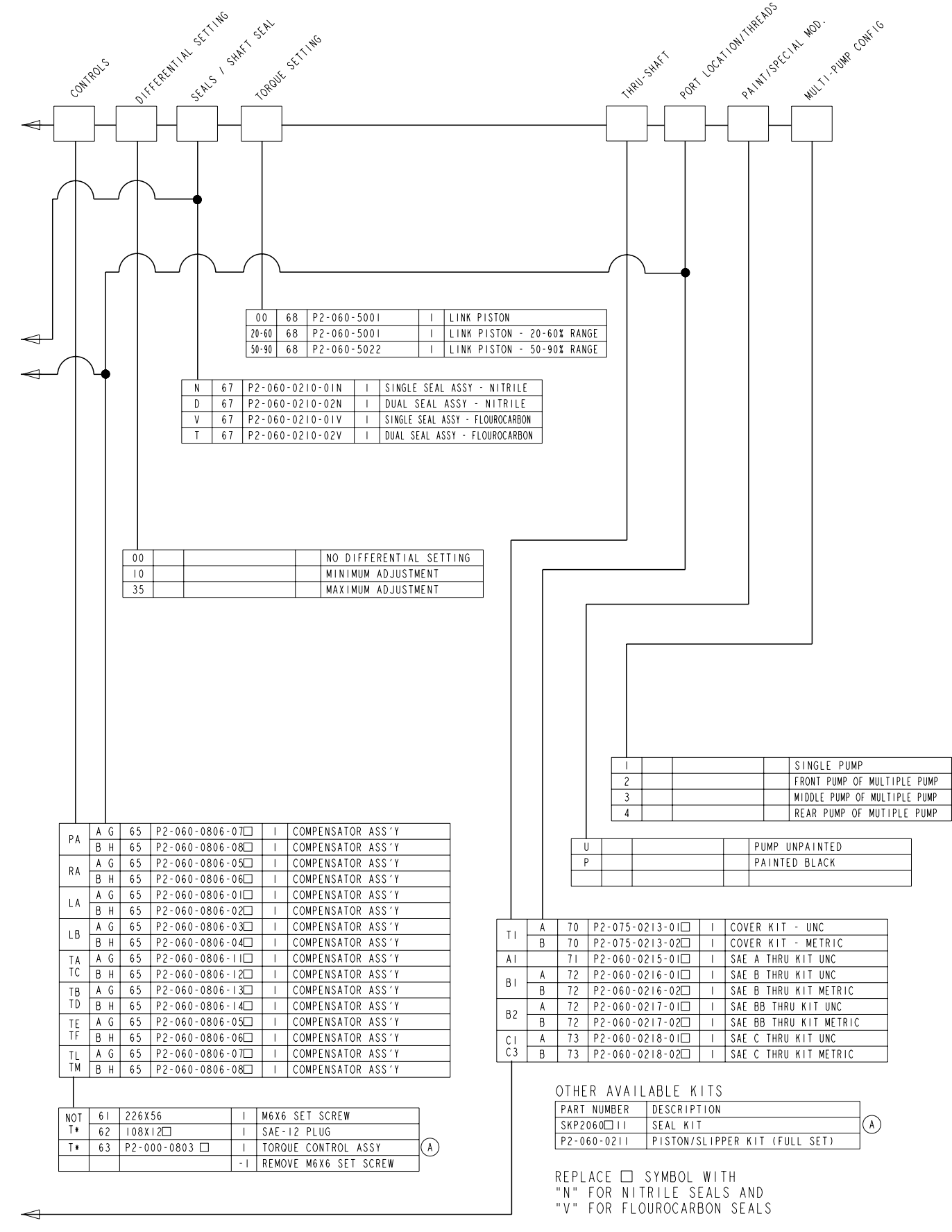
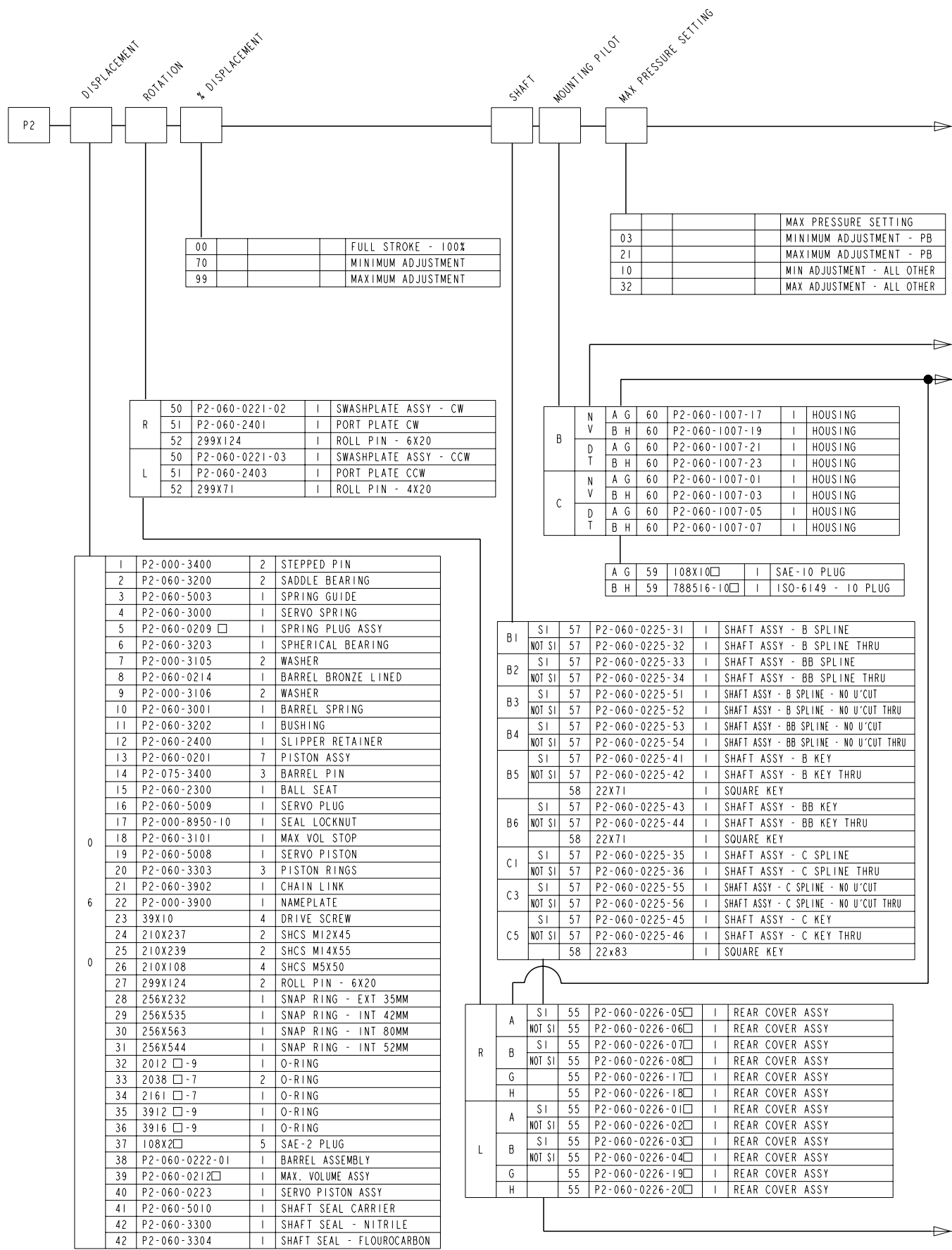

OTHER AVAILABLE KITS

PART NUMBER	DESCRIPTION
SKP2060	SEAL KIT
P2-060-0211	PISTON/SLIPPER KIT (FULL SET)

REPLACE  SYMBOL WITH "N" FOR NITRILE SEALS AND "V" FOR FLOUROCARBON SEALS

