



P2/P3 Series Piston Pumps Variable Displacement

Catalog HY28-2662-CD/US



General Information

The newly developed variable displacement piston pumps from Parker Hannifin, designated "P2", are intended for mobile applications, featuring a very compact design, low noise level and low pressure ripple.

The pumps are very stable and respond quickly to system demands in many different types of mobile machinery, and are designed for cost effective installation within the limited space available on modern mobile machines.

The P2 series is available in four frame sizes from 60 to 145 cm³/rev and features control options that are suitable for most mobile vehicle applications.

The P3 offers a built-in impeller to suit applications requiring higher self-priming speeds or when the vehicle is operating in high altitudes.

The P3 pump line is available in three frame sizes from 75 to 145 cm³/rev and features control options that are suitable for most mobile applications. Both of these pumps offer benefits like:

- **Compact and easy to install**
- **Less noise to insulate**
- **High self-priming speeds**
- **Gauge ports are standard**

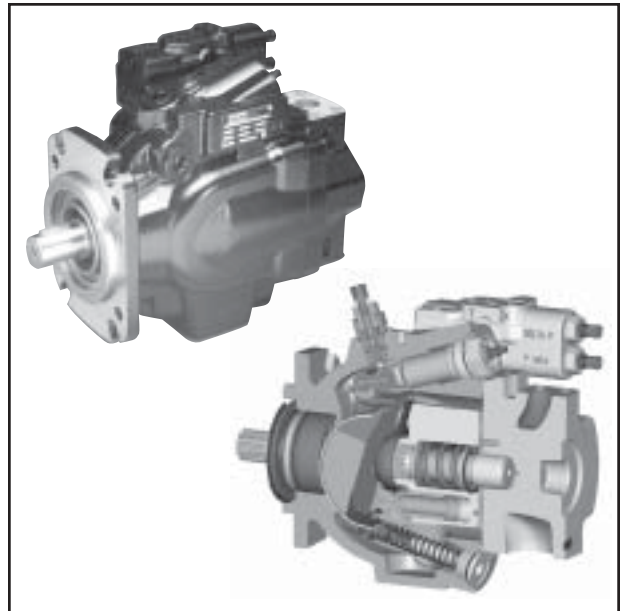
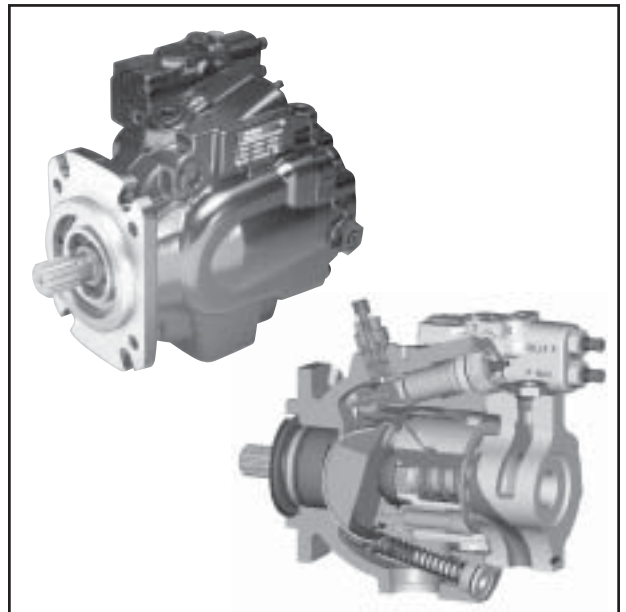
P2 Series**P3 Series**

Ordering Information

	Pump Series	Displacement	Shaft Rotation	Percent of Max Displacement	Shaft Options	Mounting Flange	Pressure Setting																																																																																																																																				
<table border="1" style="width:100%; border-collapse: collapse;"> <thead> <tr> <th>Series</th> <th></th> </tr> </thead> <tbody> <tr> <td>P2</td> <td>Standard</td> </tr> <tr> <td>P3</td> <td>Supercharged</td> </tr> </tbody> </table> <table border="1" style="width:100%; border-collapse: collapse;"> <thead> <tr> <th>Code</th> <th>Displacement</th> <th>P2</th> <th>P3</th> </tr> </thead> <tbody> <tr> <td>060</td> <td>60 cm³/rev (3.70 in³/rev)</td> <td>X</td> <td style="background-color: #cccccc;"></td> </tr> <tr> <td>075</td> <td>75 cm³/rev (4.58 in³/rev)</td> <td>X</td> <td>X</td> </tr> <tr> <td>105</td> <td>105 cm³/rev (6.41 in³/rev)</td> <td>X</td> <td>X</td> </tr> <tr> <td>145</td> <td>145 cm³/rev (8.85 in³/rev)</td> <td>X</td> <td>X</td> </tr> </tbody> </table> <table border="1" style="width:100%; border-collapse: collapse;"> <thead> <tr> <th>Code</th> <th>Rotation¹</th> </tr> </thead> <tbody> <tr> <td>R</td> <td>CW</td> </tr> <tr> <td>L</td> <td>CCW</td> </tr> </tbody> </table> <p style="font-size: small; margin-left: 20px;">¹As viewed from shaft end</p> <table border="1" style="width:100%; border-collapse: collapse;"> <thead> <tr> <th>Code</th> <th>Percent of Max Displacement</th> </tr> </thead> <tbody> <tr> <td>00</td> <td>100% stroke, standard factory setting</td> </tr> <tr> <td>XX</td> <td>Range is 70-99 (70%-99%)</td> </tr> </tbody> </table> <table border="1" style="width:100%; border-collapse: collapse;"> <thead> <tr> <th colspan="5">Shaft Options</th> </tr> <tr> <th>Code</th> <th></th> <th>060</th> <th>075</th> <th>105</th> <th>145</th> </tr> </thead> <tbody> <tr> <td>B1</td> <td>SAE B Spline¹</td> <td>X</td> <td style="background-color: #cccccc;"></td> <td style="background-color: #cccccc;"></td> <td style="background-color: #cccccc;"></td> </tr> <tr> <td>B2</td> <td>SAE BB Spline</td> <td>X</td> <td style="background-color: #cccccc;"></td> <td style="background-color: #cccccc;"></td> <td style="background-color: #cccccc;"></td> </tr> <tr> <td>C1</td> <td>SAE C Spline</td> <td>X</td> <td>X</td> <td>X</td> <td>X</td> </tr> <tr> <td>C2</td> <td>SAE CC Spline²</td> <td style="background-color: #cccccc;"></td> <td>X</td> <td>X</td> <td style="background-color: #cccccc;"></td> </tr> <tr> <td>C3</td> <td>SAE C Spline²</td> <td style="background-color: #cccccc;"></td> <td>X</td> <td>X</td> <td>X</td> </tr> <tr> <td>C5</td> <td>SAE C Key</td> <td>X</td> <td>X</td> <td>X</td> <td>X</td> </tr> <tr> <td>C6</td> <td>SAE CC Key²</td> <td style="background-color: #cccccc;"></td> <td>X</td> <td>X</td> <td>X</td> </tr> <tr> <td>D1</td> <td>SAE D Spline</td> <td style="background-color: #cccccc;"></td> <td style="background-color: #cccccc;"></td> <td>X</td> <td>X</td> </tr> <tr> <td>D3</td> <td>SAE D Key</td> <td style="background-color: #cccccc;"></td> <td style="background-color: #cccccc;"></td> <td style="background-color: #cccccc;"></td> <td>X</td> </tr> </tbody> </table> <p style="font-size: small; margin-left: 20px;">¹ 060 non thru drive only ² 075 thru drive version only</p> <table border="1" style="width:100%; border-collapse: collapse;"> <thead> <tr> <th colspan="5">Mounting Flange</th> </tr> <tr> <th>Code</th> <th></th> <th>060</th> <th>075</th> <th>105</th> <th>145</th> </tr> </thead> <tbody> <tr> <td>B</td> <td>SAE B 2-bolt</td> <td style="background-color: #cccccc;"></td> <td style="background-color: #cccccc;"></td> <td style="background-color: #cccccc;"></td> <td style="background-color: #cccccc;"></td> </tr> <tr> <td>C</td> <td>SAE C 4-bolt</td> <td style="background-color: #cccccc;"></td> <td>SAE C 2/4-bolt</td> <td>SAE C 2/4-bolt</td> <td>SAE C 2-bolt</td> </tr> <tr> <td>D</td> <td style="background-color: #cccccc;"></td> <td style="background-color: #cccccc;"></td> <td style="background-color: #cccccc;"></td> <td style="background-color: #cccccc;"></td> <td>SAE D 4-bolt</td> </tr> </tbody> </table>	Series		P2	Standard	P3	Supercharged	Code	Displacement	P2	P3	060	60 cm ³ /rev (3.70 in ³ /rev)	X		075	75 cm ³ /rev (4.58 in ³ /rev)	X	X	105	105 cm ³ /rev (6.41 in ³ /rev)	X	X	145	145 cm ³ /rev (8.85 in ³ /rev)	X	X	Code	Rotation ¹	R	CW	L	CCW	Code	Percent of Max Displacement	00	100% stroke, standard factory setting	XX	Range is 70-99 (70%-99%)	Shaft Options					Code		060	075	105	145	B1	SAE B Spline ¹	X				B2	SAE BB Spline	X				C1	SAE C Spline	X	X	X	X	C2	SAE CC Spline ²		X	X		C3	SAE C Spline ²		X	X	X	C5	SAE C Key	X	X	X	X	C6	SAE CC Key ²		X	X	X	D1	SAE D Spline			X	X	D3	SAE D Key				X	Mounting Flange					Code		060	075	105	145	B	SAE B 2-bolt					C	SAE C 4-bolt		SAE C 2/4-bolt	SAE C 2/4-bolt	SAE C 2-bolt	D					SAE D 4-bolt							
Series																																																																																																																																											
P2	Standard																																																																																																																																										
P3	Supercharged																																																																																																																																										
Code	Displacement	P2	P3																																																																																																																																								
060	60 cm ³ /rev (3.70 in ³ /rev)	X																																																																																																																																									
075	75 cm ³ /rev (4.58 in ³ /rev)	X	X																																																																																																																																								
105	105 cm ³ /rev (6.41 in ³ /rev)	X	X																																																																																																																																								
145	145 cm ³ /rev (8.85 in ³ /rev)	X	X																																																																																																																																								
Code	Rotation ¹																																																																																																																																										
R	CW																																																																																																																																										
L	CCW																																																																																																																																										
Code	Percent of Max Displacement																																																																																																																																										
00	100% stroke, standard factory setting																																																																																																																																										
XX	Range is 70-99 (70%-99%)																																																																																																																																										
Shaft Options																																																																																																																																											
Code		060	075	105	145																																																																																																																																						
B1	SAE B Spline ¹	X																																																																																																																																									
B2	SAE BB Spline	X																																																																																																																																									
C1	SAE C Spline	X	X	X	X																																																																																																																																						
C2	SAE CC Spline ²		X	X																																																																																																																																							
C3	SAE C Spline ²		X	X	X																																																																																																																																						
C5	SAE C Key	X	X	X	X																																																																																																																																						
C6	SAE CC Key ²		X	X	X																																																																																																																																						
D1	SAE D Spline			X	X																																																																																																																																						
D3	SAE D Key				X																																																																																																																																						
Mounting Flange																																																																																																																																											
Code		060	075	105	145																																																																																																																																						
B	SAE B 2-bolt																																																																																																																																										
C	SAE C 4-bolt		SAE C 2/4-bolt	SAE C 2/4-bolt	SAE C 2-bolt																																																																																																																																						
D					SAE D 4-bolt																																																																																																																																						

P2/P3 Torque Control Options TA, TB, TC, TD Ordering Guide

	Maximum Rated Torque		TA/TB Adjustment Range 20%-60% of Max Torque		TC/TD Adjustment Range 50%-90% of Max Torque	
	Nm	Lb. In.	Nm	Lb. In.	Nm	Lb. In.
	P2/P3060	339	3004	68-204	600-1802	170-306
P2/P3075	424	3755	85-254	751-2253	212-382	1877-3379
P2/P3105	594	5257	119-356	1051-3154	297-535	2628-4731
P2/P3145	820	7259	164-492	1451-4355	410-738	3629-6533

Code Pressure Setting

XX Factory max setting, in Bar times 10 (100-320 bar range)

For example "32" = 320 Bar Pressure Compensator Setting

The input torque limit is factory set at a percentage of the maximum rated input torque. The percentage needs to be specified in Torque Control Setting (%) box of the ordering code. For example, for a P2/P3075-TC pump with an input torque limit setting required of 300Nm, divide 300 into 424, which equals 71%, so 71 is specified in Torque Control Setting (%) box.

Ordering Information

Controls	Differential Pressure Setting	Seal Type	Torque Control Setting (%)	Thru Drive	Port Location	Multiple Pump Option	Paint Option																				
						<table border="1"> <thead> <tr> <th>Code</th> <th>Multiple Pump Option</th> </tr> </thead> <tbody> <tr> <td>1</td> <td>Single pump</td> </tr> <tr> <td>2⁵</td> <td>Front pump of multiple pump combination</td> </tr> <tr> <td>3⁵</td> <td>Middle pump of multiple pump combination</td> </tr> <tr> <td>4⁵</td> <td>Rear pump of multiple pump combination</td> </tr> </tbody> </table> <p>⁵Multiple pump assemblies must be ordered on the same purchase order and must be comprised of Parker piston pumps only</p>	Code	Multiple Pump Option	1	Single pump	2 ⁵	Front pump of multiple pump combination	3 ⁵	Middle pump of multiple pump combination	4 ⁵	Rear pump of multiple pump combination											
Code	Multiple Pump Option																										
1	Single pump																										
2 ⁵	Front pump of multiple pump combination																										
3 ⁵	Middle pump of multiple pump combination																										
4 ⁵	Rear pump of multiple pump combination																										
					<table border="1"> <thead> <tr> <th>Code</th> <th>Port Location</th> </tr> </thead> <tbody> <tr> <td>A</td> <td>Side flanges - UNC</td> </tr> <tr> <td>B</td> <td>Side flanges - ISO6149 (metric)</td> </tr> <tr> <td>G⁴</td> <td>Rear flanges - UNC</td> </tr> <tr> <td>H⁴</td> <td>Rear flanges - ISO6149 (metric)</td> </tr> </tbody> </table> <p>⁴P2060 and P2075 only</p>	Code	Port Location	A	Side flanges - UNC	B	Side flanges - ISO6149 (metric)	G ⁴	Rear flanges - UNC	H ⁴	Rear flanges - ISO6149 (metric)												
Code	Port Location																										
A	Side flanges - UNC																										
B	Side flanges - ISO6149 (metric)																										
G ⁴	Rear flanges - UNC																										
H ⁴	Rear flanges - ISO6149 (metric)																										
				<table border="1"> <thead> <tr> <th>Code</th> <th>Thru Drive</th> </tr> </thead> <tbody> <tr> <td>S1</td> <td>No thru drive</td> </tr> <tr> <td>T1</td> <td>Thru drive with cover, no coupling</td> </tr> <tr> <td>A1</td> <td>SAE A - 2 bolt, A spline</td> </tr> <tr> <td>B1</td> <td>SAE B - 2 bolt, B spline</td> </tr> <tr> <td>B2</td> <td>SAE B - 2 bolt, BB spline</td> </tr> <tr> <td>C1</td> <td>SAE C - 2 bolt, C spline</td> </tr> <tr> <td>C2</td> <td>SAE C - 2 bolt, CC spline (145 only)</td> </tr> <tr> <td>C3</td> <td>SAE C - 4 bolt, C spline</td> </tr> <tr> <td>C4</td> <td>SAE C - 4 bolt, CC spline (145 only)</td> </tr> <tr> <td>D3</td> <td>SAE D - 4 bolt, D spline (145 only)</td> </tr> </tbody> </table>	Code	Thru Drive	S1	No thru drive	T1	Thru drive with cover, no coupling	A1	SAE A - 2 bolt, A spline	B1	SAE B - 2 bolt, B spline	B2	SAE B - 2 bolt, BB spline	C1	SAE C - 2 bolt, C spline	C2	SAE C - 2 bolt, CC spline (145 only)	C3	SAE C - 4 bolt, C spline	C4	SAE C - 4 bolt, CC spline (145 only)	D3	SAE D - 4 bolt, D spline (145 only)	
Code	Thru Drive																										
S1	No thru drive																										
T1	Thru drive with cover, no coupling																										
A1	SAE A - 2 bolt, A spline																										
B1	SAE B - 2 bolt, B spline																										
B2	SAE B - 2 bolt, BB spline																										
C1	SAE C - 2 bolt, C spline																										
C2	SAE C - 2 bolt, CC spline (145 only)																										
C3	SAE C - 4 bolt, C spline																										
C4	SAE C - 4 bolt, CC spline (145 only)																										
D3	SAE D - 4 bolt, D spline (145 only)																										
			<table border="1"> <thead> <tr> <th>Code</th> <th>Torque Control Setting in %</th> </tr> </thead> <tbody> <tr> <td>00</td> <td>Standard setting for non-torque control pumps</td> </tr> <tr> <td>XX³</td> <td>20 to 90% of max. rated torque</td> </tr> </tbody> </table> <p>³See chart on previous page for information and examples.</p>	Code	Torque Control Setting in %	00	Standard setting for non-torque control pumps	XX ³	20 to 90% of max. rated torque																		
Code	Torque Control Setting in %																										
00	Standard setting for non-torque control pumps																										
XX ³	20 to 90% of max. rated torque																										
		<table border="1"> <thead> <tr> <th>Code</th> <th>Seal Type</th> </tr> </thead> <tbody> <tr> <td>N</td> <td>Nitrile, single shaft seal</td> </tr> <tr> <td>D</td> <td>Nitrile, double shaft seal - "wet flange"</td> </tr> <tr> <td>V</td> <td>Fluorocarbon, single shaft seal</td> </tr> <tr> <td>T</td> <td>Fluorocarbon, double shaft seal - "wet flange"</td> </tr> </tbody> </table>	Code	Seal Type	N	Nitrile, single shaft seal	D	Nitrile, double shaft seal - "wet flange"	V	Fluorocarbon, single shaft seal	T	Fluorocarbon, double shaft seal - "wet flange"				<table border="1"> <thead> <tr> <th>Code</th> <th>Paint Option</th> </tr> </thead> <tbody> <tr> <td>P</td> <td>Parker Black</td> </tr> <tr> <td>U</td> <td>No paint</td> </tr> </tbody> </table>	Code	Paint Option	P	Parker Black	U	No paint					
Code	Seal Type																										
N	Nitrile, single shaft seal																										
D	Nitrile, double shaft seal - "wet flange"																										
V	Fluorocarbon, single shaft seal																										
T	Fluorocarbon, double shaft seal - "wet flange"																										
Code	Paint Option																										
P	Parker Black																										
U	No paint																										
	<table border="1"> <thead> <tr> <th>Code</th> <th>Differential Pressure Setting</th> </tr> </thead> <tbody> <tr> <td>20</td> <td>Recommended Initial Factory Setting</td> </tr> <tr> <td>00</td> <td>Use with PA Control Only</td> </tr> <tr> <td>XX</td> <td>Pressure Setting in Bar - Range 10-35</td> </tr> </tbody> </table>	Code	Differential Pressure Setting	20	Recommended Initial Factory Setting	00	Use with PA Control Only	XX	Pressure Setting in Bar - Range 10-35																		
Code	Differential Pressure Setting																										
20	Recommended Initial Factory Setting																										
00	Use with PA Control Only																										
XX	Pressure Setting in Bar - Range 10-35																										
<table border="1"> <thead> <tr> <th>Code</th> <th>Controls</th> </tr> </thead> <tbody> <tr> <td>PA</td> <td>Standard Max Pressure Control (Pmax) 100-320 Bar (1450-4600 PSI)</td> </tr> <tr> <td>RA</td> <td>Remote/Pmax 100-320 Bar (1450-4600 PSI)</td> </tr> <tr> <td>LA</td> <td>Load sensing (2 spool)/Pmax without bleed orifice</td> </tr> <tr> <td>LB</td> <td>Load sensing (2 spool)/Pmax with bleed orifice</td> </tr> <tr> <td>TA³</td> <td>Torque/LS/Pmax without bleed orifice (2 spool) - torque range 20-60% of max rated torque</td> </tr> <tr> <td>TB³</td> <td>Torque/LS/Pmax with bleed orifice (2 spool) - torque range 20-60% of max rated torque</td> </tr> <tr> <td>TC³</td> <td>Torque/LS/Pmax without bleed orifice (2 spool) - torque range 50-90% of max rated torque</td> </tr> <tr> <td>TD³</td> <td>Torque/LS/Pmax with bleed orifice (2 spool) - torque range 50-90% of max rated torque</td> </tr> </tbody> </table>								Code	Controls	PA	Standard Max Pressure Control (Pmax) 100-320 Bar (1450-4600 PSI)	RA	Remote/Pmax 100-320 Bar (1450-4600 PSI)	LA	Load sensing (2 spool)/Pmax without bleed orifice	LB	Load sensing (2 spool)/Pmax with bleed orifice	TA ³	Torque/LS/Pmax without bleed orifice (2 spool) - torque range 20-60% of max rated torque	TB ³	Torque/LS/Pmax with bleed orifice (2 spool) - torque range 20-60% of max rated torque	TC ³	Torque/LS/Pmax without bleed orifice (2 spool) - torque range 50-90% of max rated torque	TD ³	Torque/LS/Pmax with bleed orifice (2 spool) - torque range 50-90% of max rated torque		
Code	Controls																										
PA	Standard Max Pressure Control (Pmax) 100-320 Bar (1450-4600 PSI)																										
RA	Remote/Pmax 100-320 Bar (1450-4600 PSI)																										
LA	Load sensing (2 spool)/Pmax without bleed orifice																										
LB	Load sensing (2 spool)/Pmax with bleed orifice																										
TA ³	Torque/LS/Pmax without bleed orifice (2 spool) - torque range 20-60% of max rated torque																										
TB ³	Torque/LS/Pmax with bleed orifice (2 spool) - torque range 20-60% of max rated torque																										
TC ³	Torque/LS/Pmax without bleed orifice (2 spool) - torque range 50-90% of max rated torque																										
TD ³	Torque/LS/Pmax with bleed orifice (2 spool) - torque range 50-90% of max rated torque																										

³See previous page for information and examples.

Technical Data

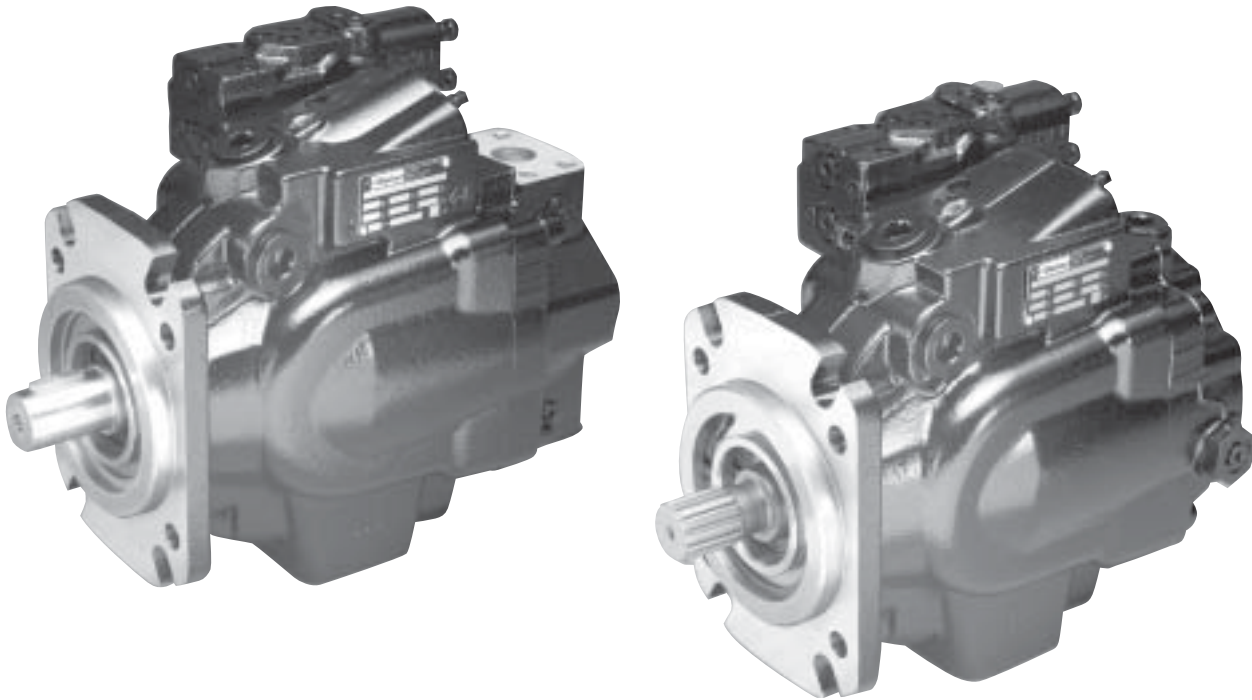

	P2 Series				P3 Series		
Frame size	P2060	P2075	P2105	P2145	P3075	P3105	P3145
Max displacement cm ³ /rev [cu in/rev]	60 3.66	75 4.58	105 6.41	145 8.85	75 4.58	105 6.41	145 8.85
Self-priming speed at 1 bar/14.5 psi abs. inlet pressure [rpm]	2800	2500	2300	2200	3000	2600	2500

Max continuous pressure bar [psi]	320 4600	320 4600	320 4600	320 4600	320 4600	320 4600	320 4600
Peak pressure bar [psi]	370 5365	370 5365	370 5365	370 5365	370 5365	370 5365	370 5365
Minimum Inlet Pressure bar abs at max speed [in Hg vacuum]	.8 5.8	.8 5.8	.8 5.8	.8 5.8	.8 5.8	.8 5.8	.8 5.8
Maximum Inlet Pressure bar [psi]	10 145	10 145	10 145	10 145	1.5 22.7	1.5 22.7	1.5 22.7
Maximum Case Drain Pressure bar continuous psi	.5 7.75	.5 7.75	.5 7.75	.5 7.75	1 14.5	1 14.5	1 14.5
Noise level at full flow, 1800 rpm, and 250 bar (3600 psi) [dbA]	74	76	78	80	76	78	80
Weight with load sense control kg [lbs]	37 81	44 97	63 139	78 172	42 92	62 136	76 167
Mass moment of inertia kg m ² (about axis of shaft)	.0061	.0101	.0168	.0241	.0106	.0177	.0264

P2/P3 Typical Control Characteristics
Typical Response Times

Input Speed: 1500 RPM
 Fluid: Mineral Oil ISO VG 32 @ 40° C

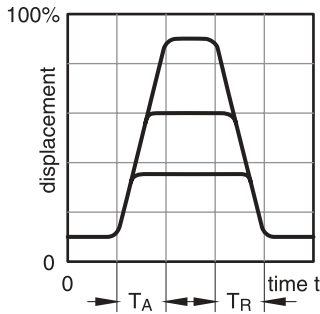

Size	Pressure Condition				
	Stand by to 250 bar	250 bar to stand by	50 bar to stand by	Stand by to 300 bar	300 bar to stand by
	Flow Condition				
	TA (ms) 0-100%	TR (ms) 100%-0	TR (ms) 100%-0	TA (ms) 0-100%	TR (ms) 100%-0
P2060	60	35	35	70	40
P2075	80	35	35	70	40
P2105	100	35	35	80	40
P2145	120	35	35	100	40
P3075	80	35	35	70	35
P3105	100	35	35	80	35
P3145	110	35	35	100	35

Differential Setting vs Standby Pressure

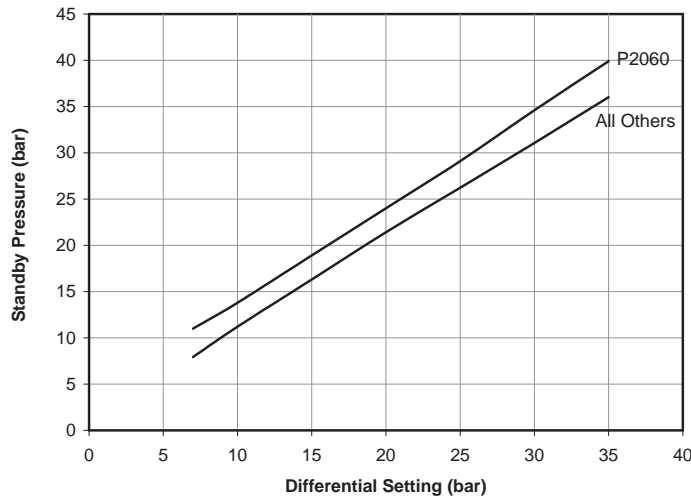

This chart shows the difference between differential pressure setting and standby pressure. The P2060 utilizes a different control from the rest of the product family. "All others" refers to all other pump sizes P2 and P3 075 thru 145.

Control Option "PA"
Pressure Compensator Control

The pressure compensator control is used to limit the maximum system pressure. The control acts such that full pump displacement is achieved unless the system valve restricts the output flow or the load pressure reaches the maximum setting of the control. If pump flow is restricted by the system valve, the pump will provide only the flow demanded, but at the maximum pressure setting of the compensator control. If the outlet flow is completely blocked, the pump will destroke to zero displacement and maintain the pressure at the setting of the compensator spring.

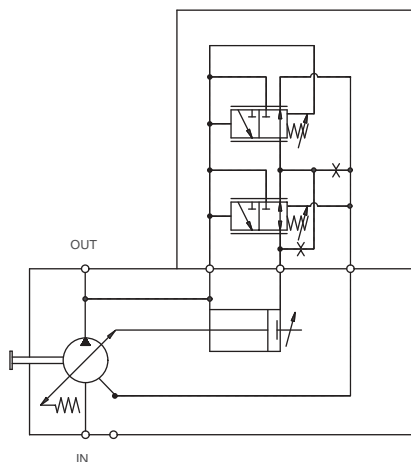
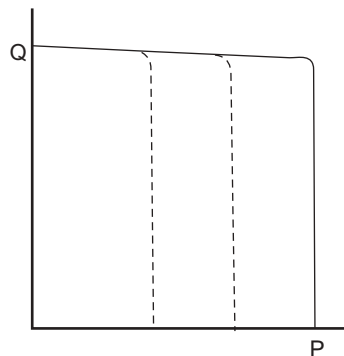

P2 Control Schematic

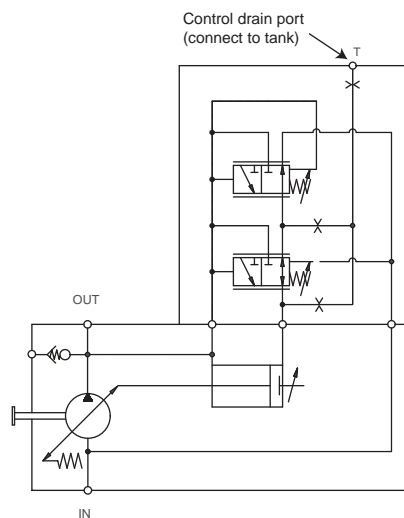

P3 Control Schematic

Control Option "RA"
Remote Pressure Compensator Control

This control allows the pump pressure compensator setting to be adjusted from a remote relief valve. The control acts such that full pump displacement is achieved unless the system valve restricts the output flow or the load pressure reaches the maximum setting of the control. If pump flow is restricted by the system valve, the pump will provide only the flow demanded, but at the maximum pressure setting of the compensator control. If the outlet flow is completely blocked, the pump will destroke to zero displacement and maintain the pressure at the setting of the remote relief valve.

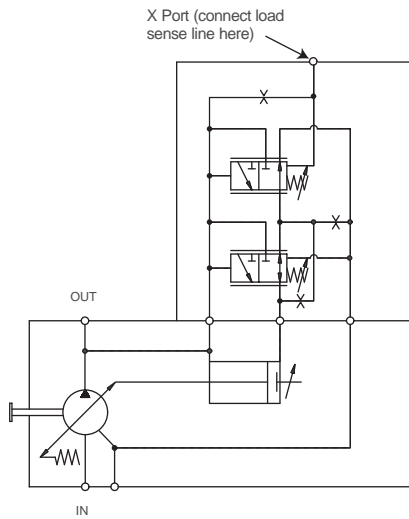
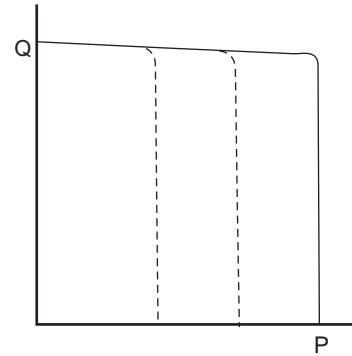

P2 Control Schematic

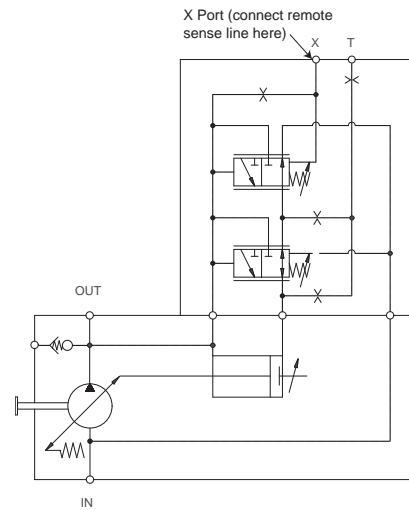

P3 Control Schematic

Control Options “LA” and “LB”
Load sensing controls with maximum pressure cut off

These controls feature load sensing and maximum pressure compensation. Load sense controls are used to match pump flow and pressure to system demands, thus minimizing losses due to wasted horsepower. The pump automatically adjusts for changes in drive speed and load pressures to match the pump output flow to the load requirement. Since the pump load sense control will maintain a constant pressure drop across the main system throttling valve, the flow rate will remain constant, independent of changes in load pressure and pump shaft speed.

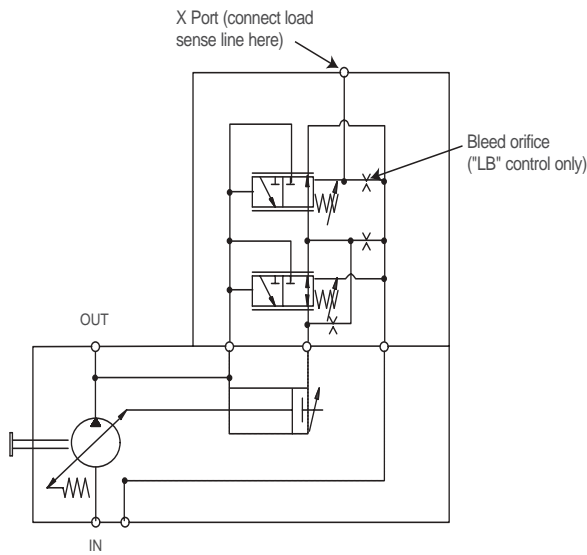
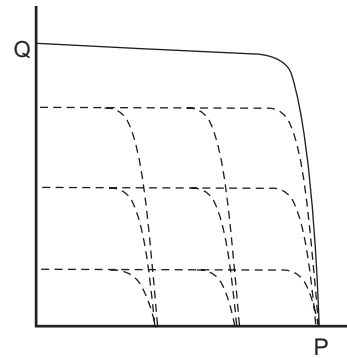

P2 Control Schematic

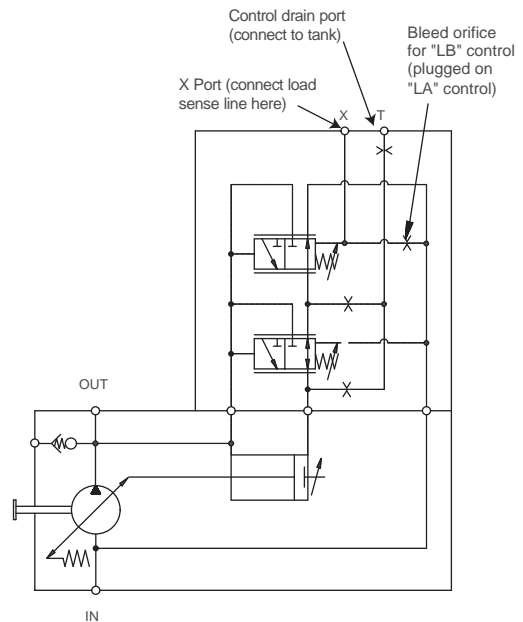

P3 Control Schematic

Control Options “TA”, “TB”, “TC” and “TD”
**Torque limiting control with load sensing and
 maximum pressure limiter**

These controls provide the benefits of the load sensing and pressure limiting controls, plus the ability to limit the input torque the pump will draw. These controls are beneficial when the power available from the prime mover for the hydraulics is limited or the application power demand has both high flow / low pressure and low flow / high pressure duty cycles.

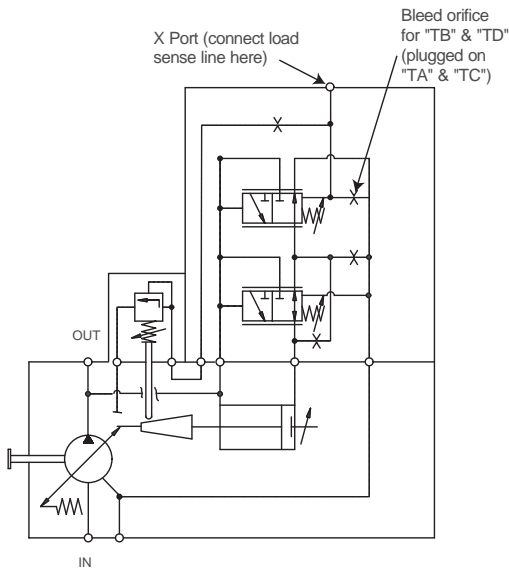
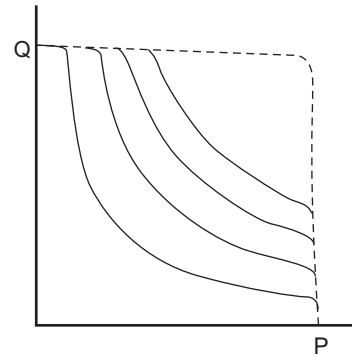

P2 Control Schematic

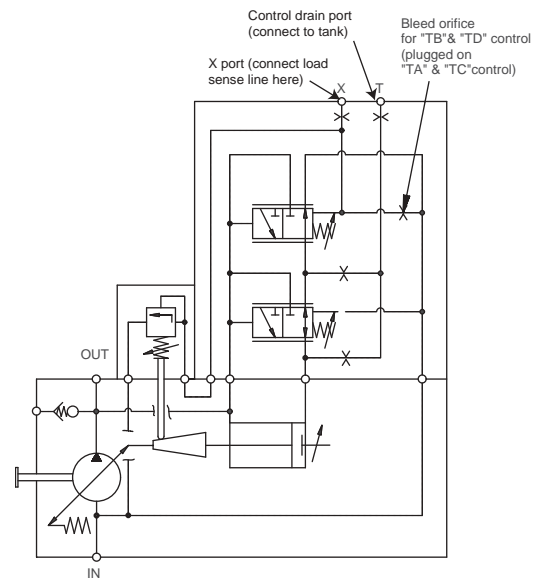

P3 Control Schematic

* See following pages for typical control characteristics

Performance Data

Ripple Chamber

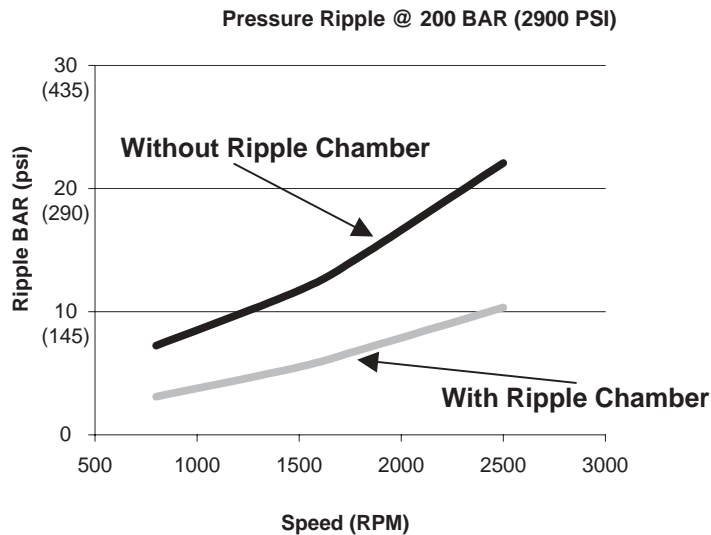

The chart above refers to the “Ripple Chamber” technology that has been engineered into the P2 and P3 series pumps. The ripple chamber reduces pressure pulsation “ripple” at the outlet of the pump. This technology reduces the ripple by 40–60%. This leads to a significant reduction in overall system noise without additional components or cost.

The ripple chamber is standard on all P2 and P3 series *side ported* pumps.

Performance Data

P2 Series Typical Torque Control Characteristics

Fluid: Mineral oil ISO VG 32 @ 40° C

Inlet pressure: 1.0 Bar (14.5 PSI) (Absolute) measured at inlet port.

**P2060 20 - 60% Torque
1800 RPM**

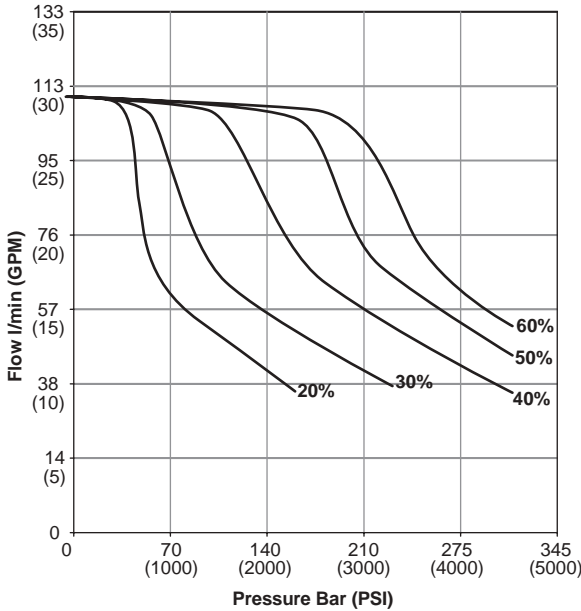

**P2060 50 - 90% Torque
1800 RPM**

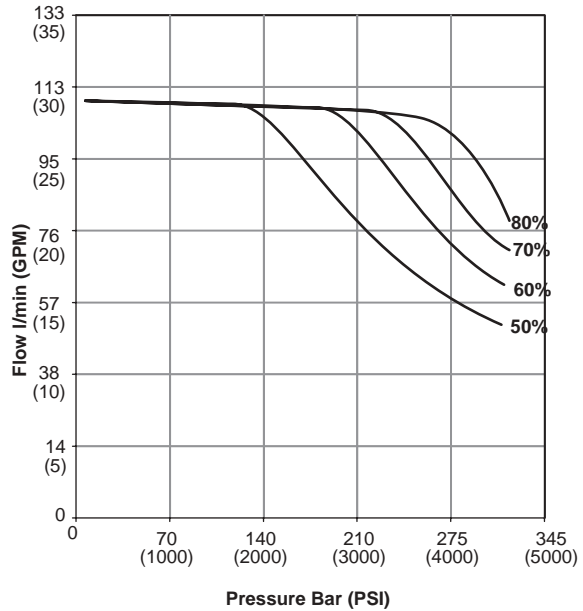

**P2075 20 - 60% Torque
1800 RPM**

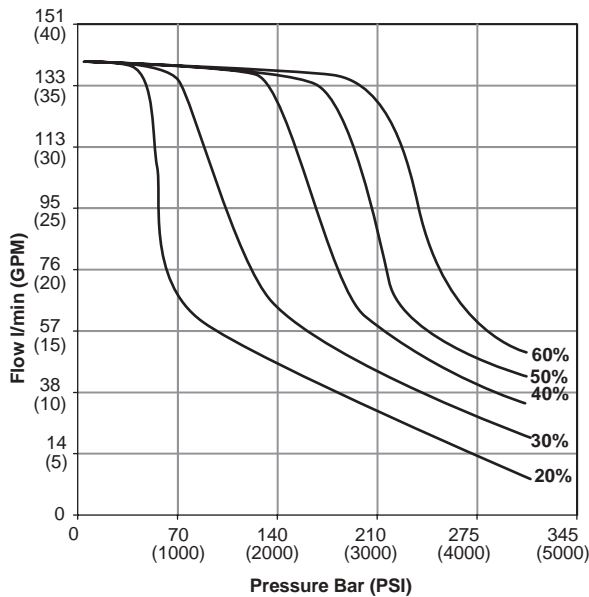

**P2075 50 - 90% Torque
1800 RPM**

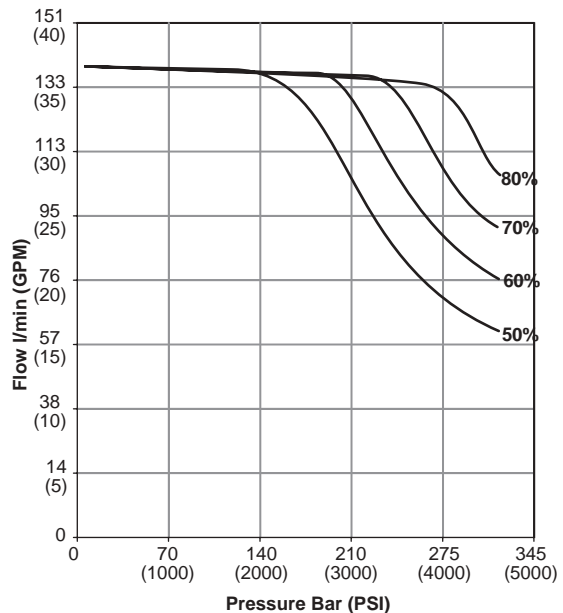

Performance Data

P2 Series Typical Torque Control Characteristics

Fluid: Mineral oil ISO VG 32 @ 40° C

Inlet pressure: 1.0 Bar (14.5 PSI) (Absolute) measured at inlet port.

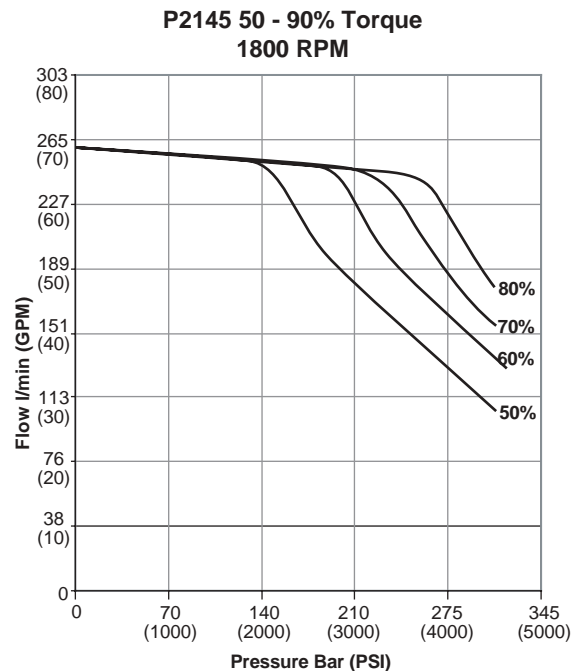
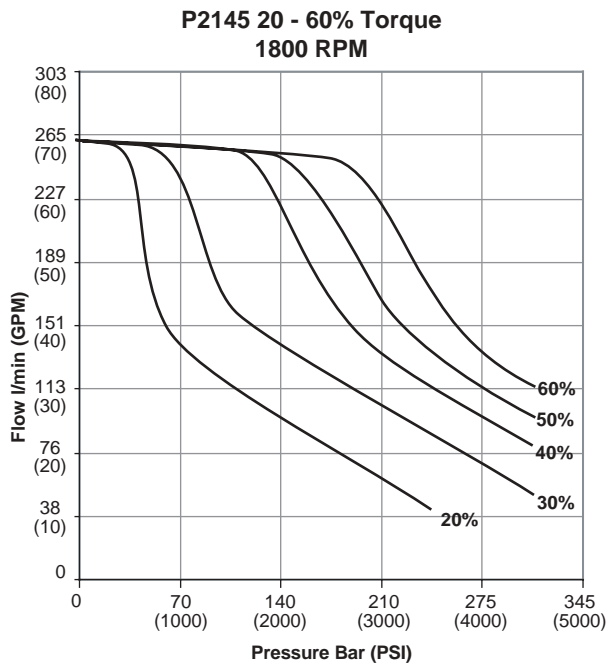
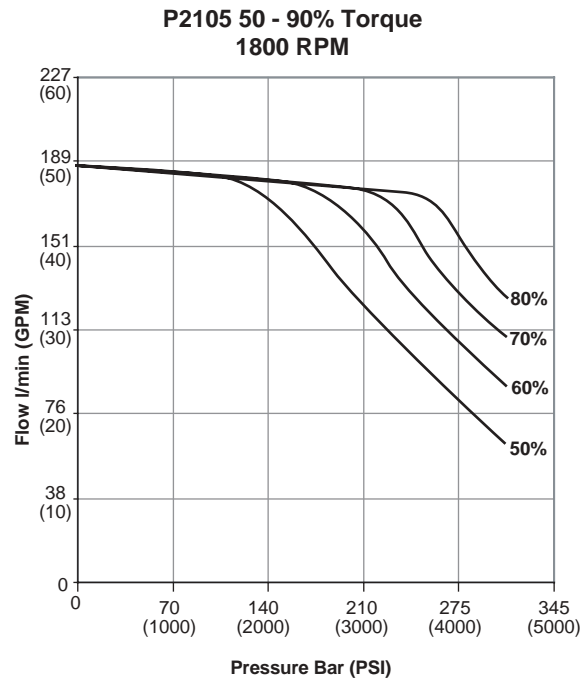
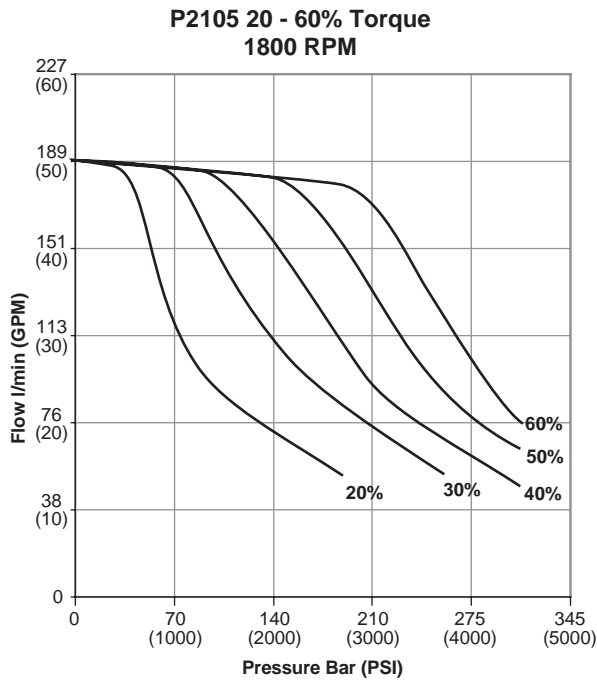

Performance Data

P2 Series Typical Noise Characteristics at Max Displacement

(These are anechoic sound pressure readings.)

Fluid: Mineral oil ISO VG 32 @ 40° C

Inlet pressure: 1.0 Bar (14.5 PSI) (Absolute) measured at inlet port.

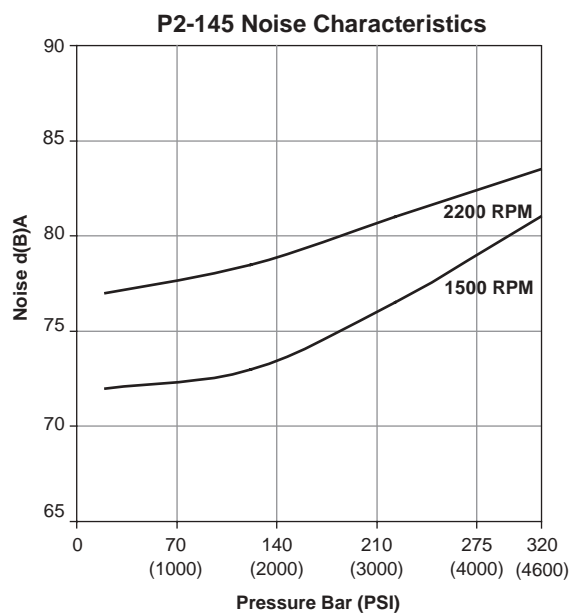
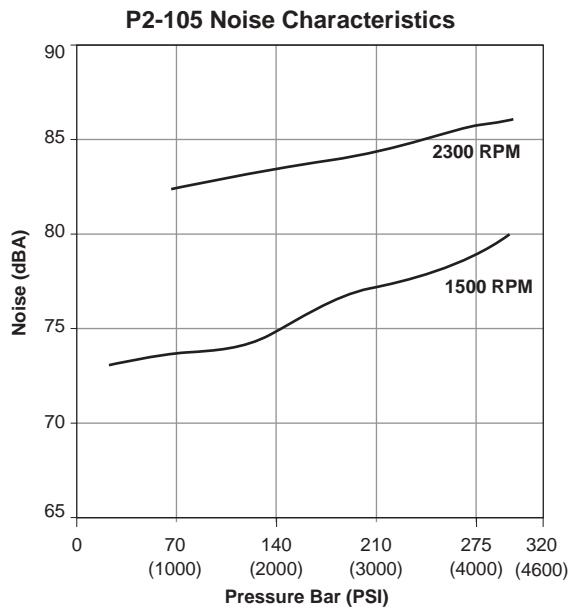
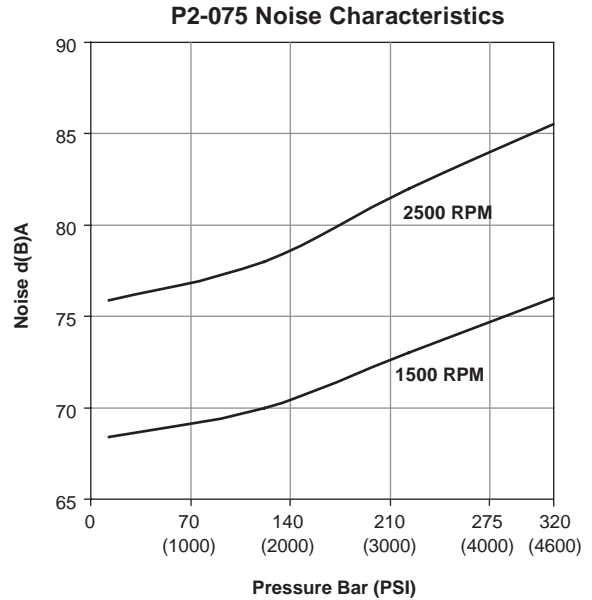
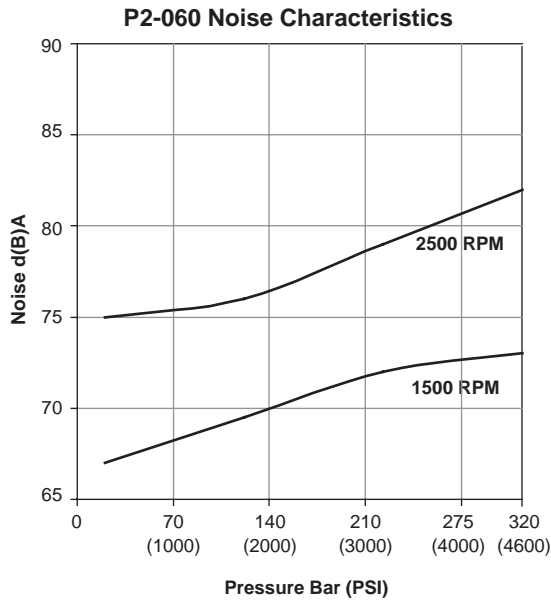

Performance Data

P2 Series Typical Drive Power at Full Displacement

Fluid: Mineral oil ISO VG 32 @ 40° C

Inlet pressure: 1.0 Bar (14.5 PSI) (Absolute) measured at inlet port.

P2060 Input Power - Full Stroke

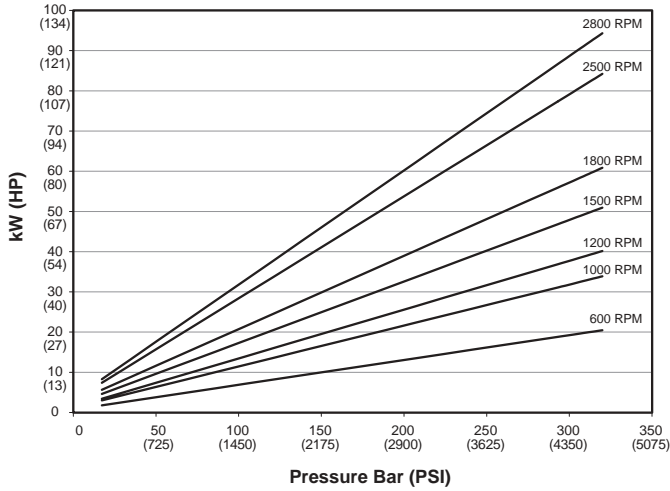

P2075 Input Power - Full Stroke

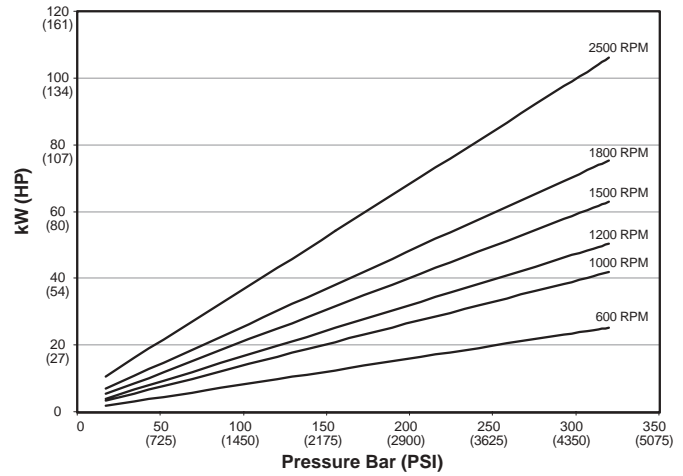

P2105 Input Power - Full Stroke

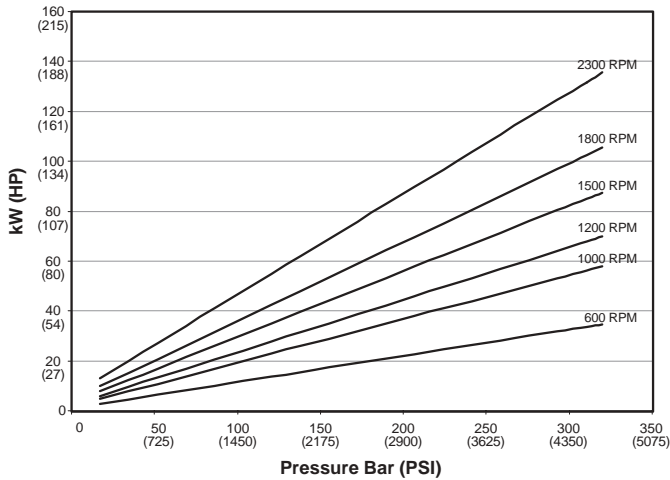

P2145 Input Power - Full Stroke

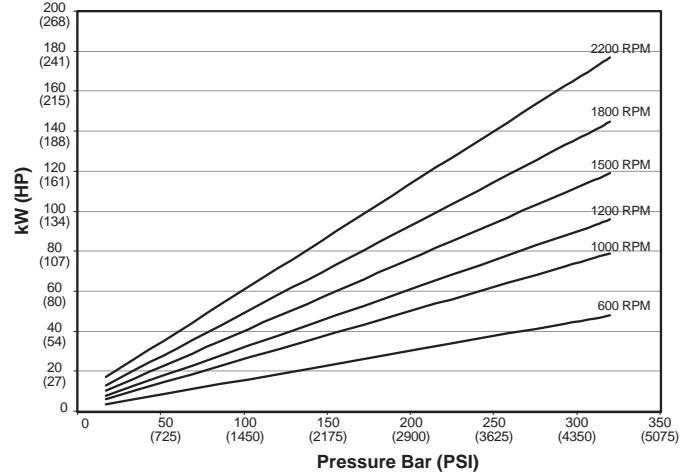

Performance Data

P2 Series Typical Compensated Power

Fluid: Mineral oil ISO VG 32 @ 40° C

Inlet pressure: 1.0 Bar (14.5 PSI) (Absolute) measured at inlet port.

P2060 Input Power - Zero Stroke

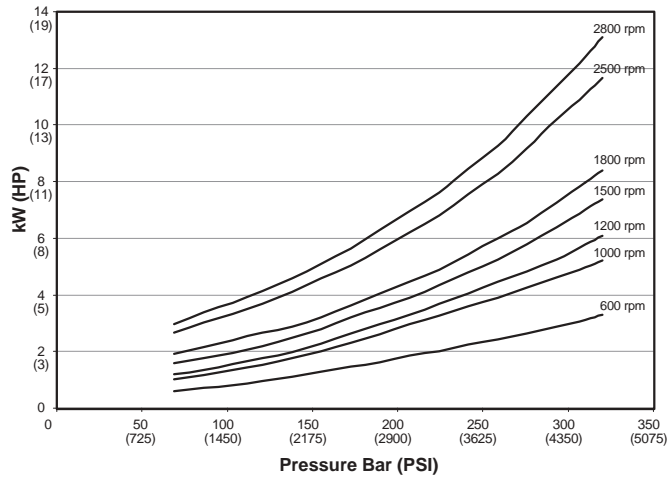

P2075 Input Power - Zero Stroke

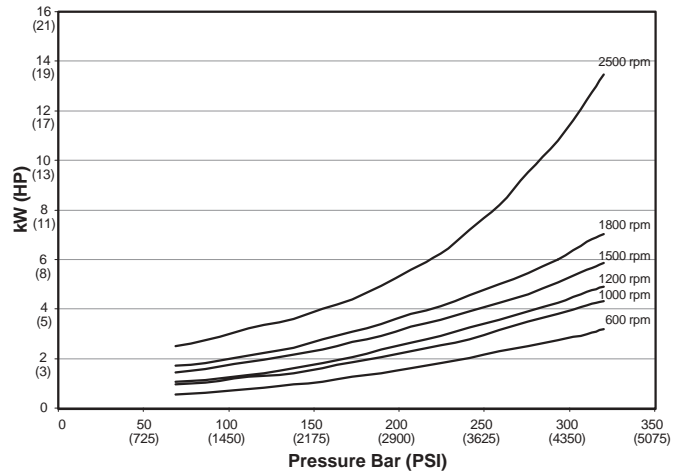

P2105 Input Power - Zero Stroke

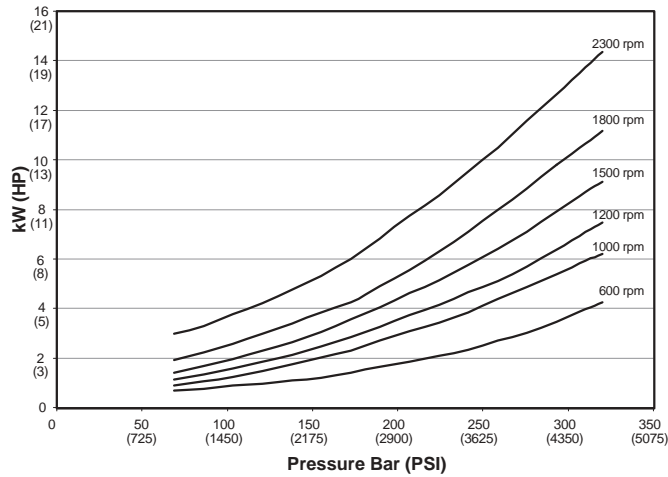

P2145 Input Power - Zero Stroke

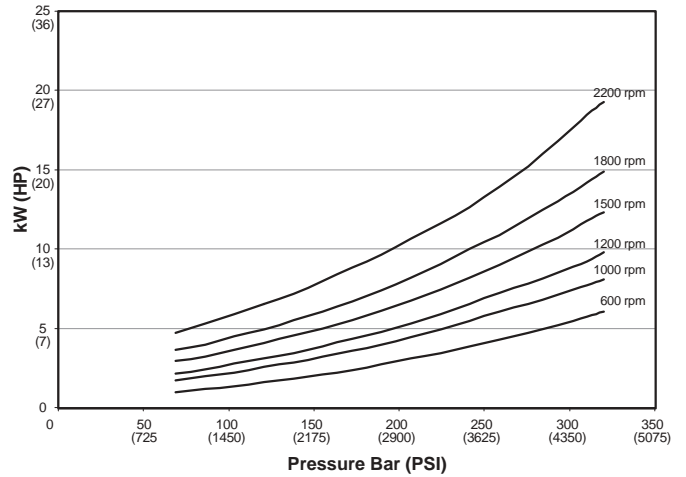

Performance Data

P2 Series Typical Efficiency at Full Displacement @ 1800 RPM

Fluid: Mineral oil ISO VG 32 @ 40° C

Inlet pressure: 1.0 Bar (14.5 PSI) (Absolute) measured at inlet port.

P2060 Efficiency at 1800 RPM

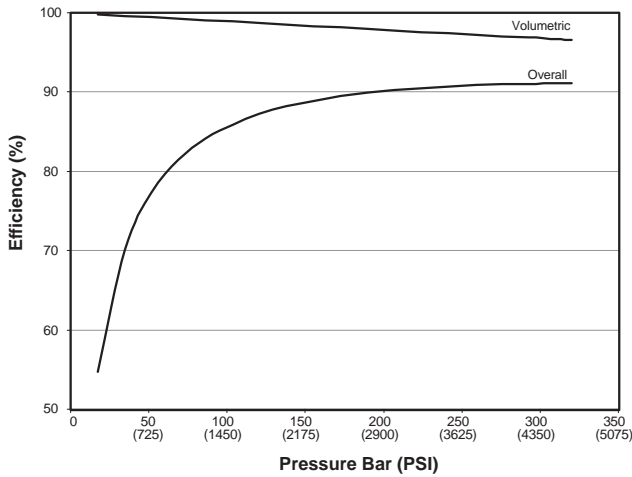

P2075 Efficiency at 1800 RPM

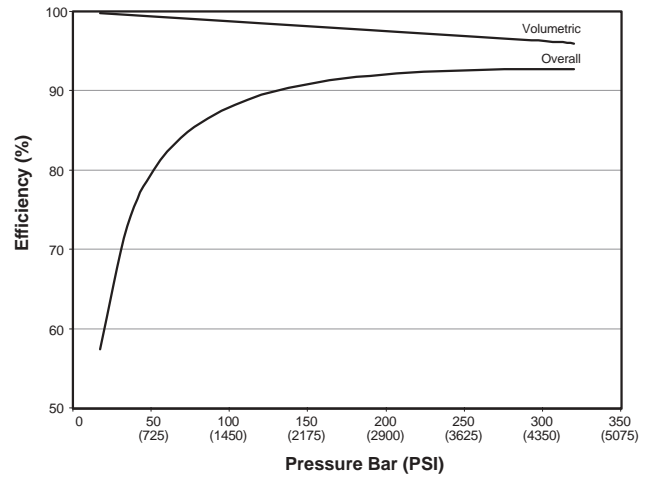

P2105 Efficiency at 1800 RPM

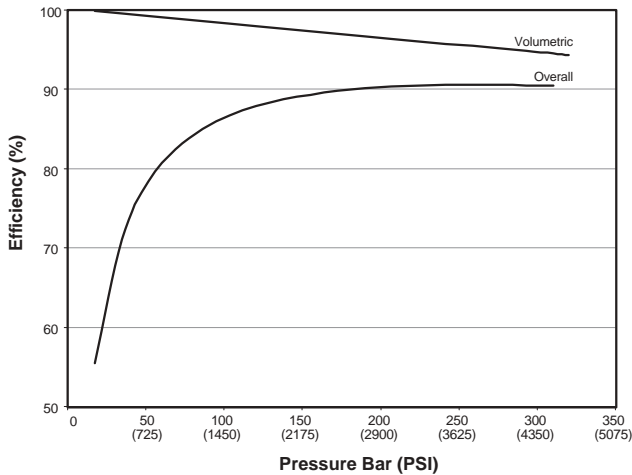

P2145 Efficiency at 1800 RPM

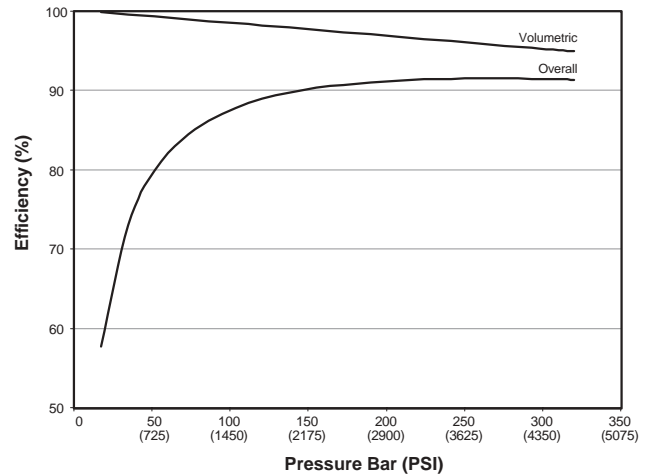

Performance Data

P2 Series Typical Flow vs. Pressure

Fluid: Mineral oil ISO VG 32 @ 40° C

Inlet pressure: 1.0 Bar (14.5 PSI) (Absolute) measured at inlet port.

P2060 Outlet Flow - Full Stroke

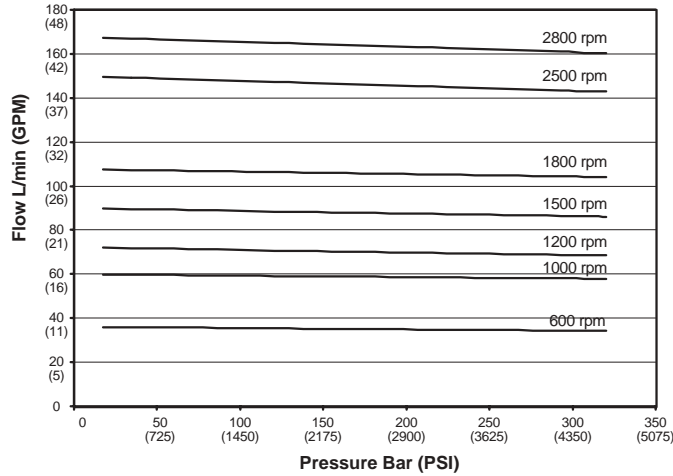

P2075 Outlet Flow - Full Stroke

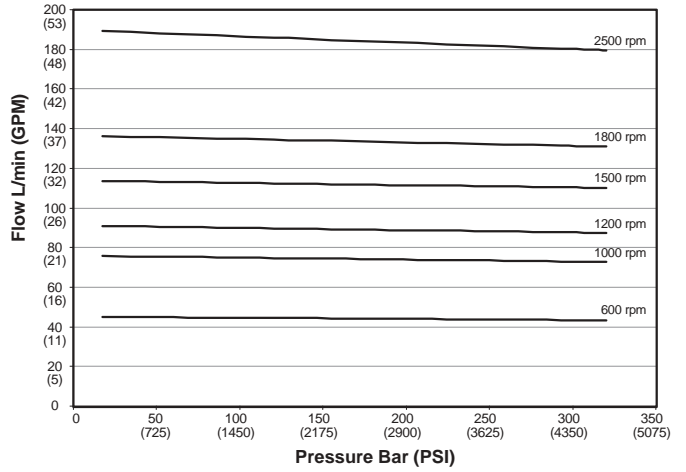

P2105 Outlet Flow - Full Stroke

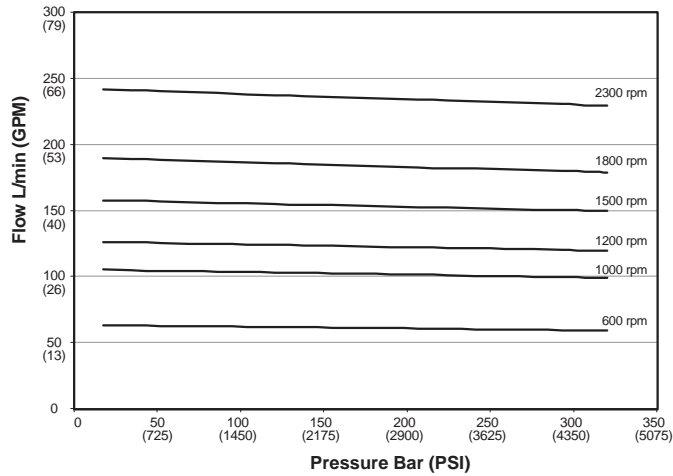

P2145 Outlet Flow - Full Stroke

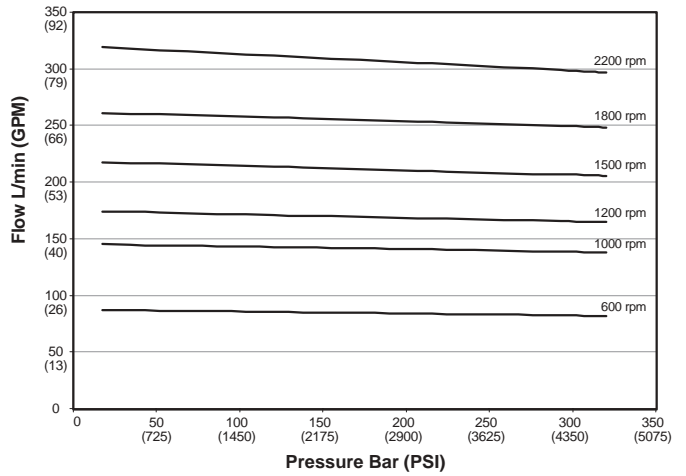

Performance Data

P2 Series Typical Compensated Case Drain Flow

Fluid: Mineral oil ISO VG 32 @ 40° C

Inlet pressure: 1.0 Bar (14.5 PSI) (Absolute) measured at inlet port.

P2060 Drain Flow at Zero Stroke

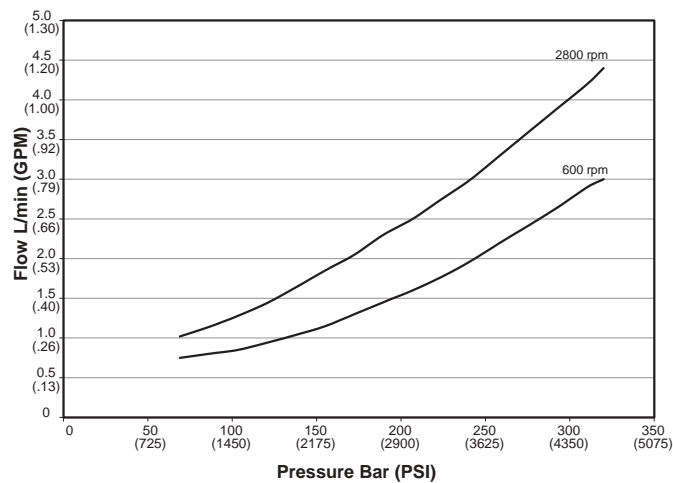

P2075 Drain Flow at Zero Stroke

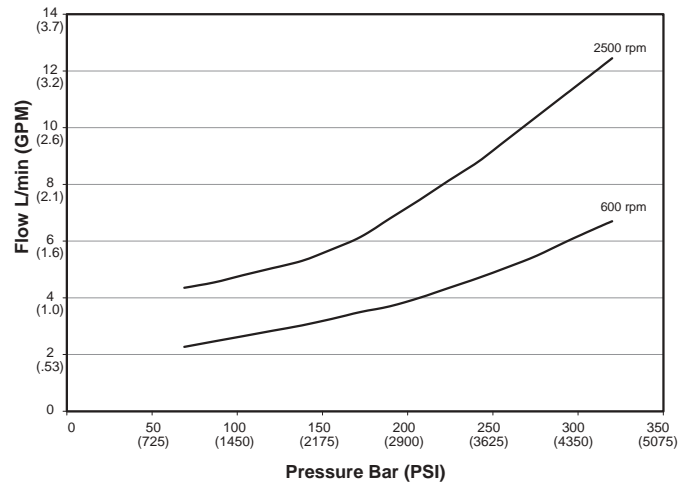

P2105 Drain Flow at Zero Stroke

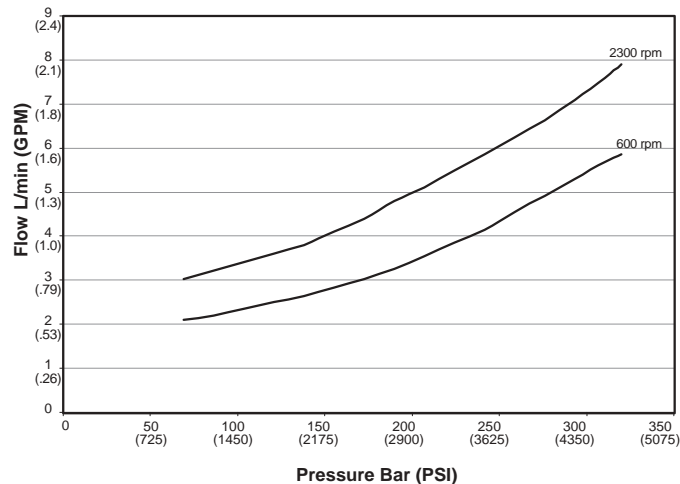

P2145 Drain Flow at Zero Stroke

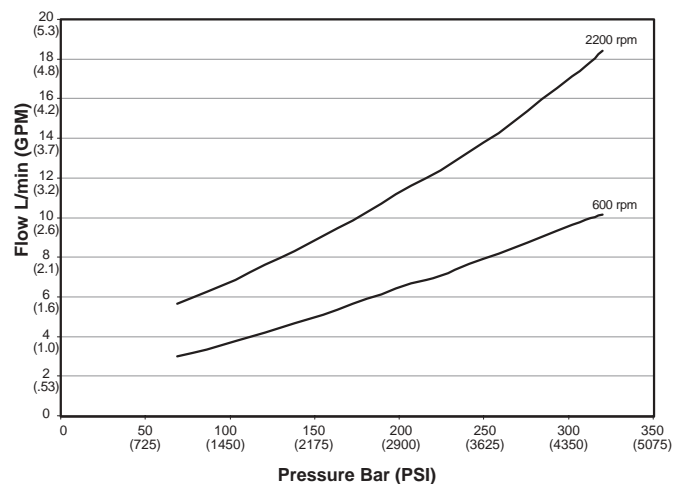

Performance Data

P2 Series Typical Inlet Characteristics vs. Speed at various percentage displacements

Fluid: Mineral oil ISO VG 32 @ 40° C

Inlet pressure: 1.0 Bar (14.5 PSI) measured at inlet port.

P2060 Inlet Characteristics

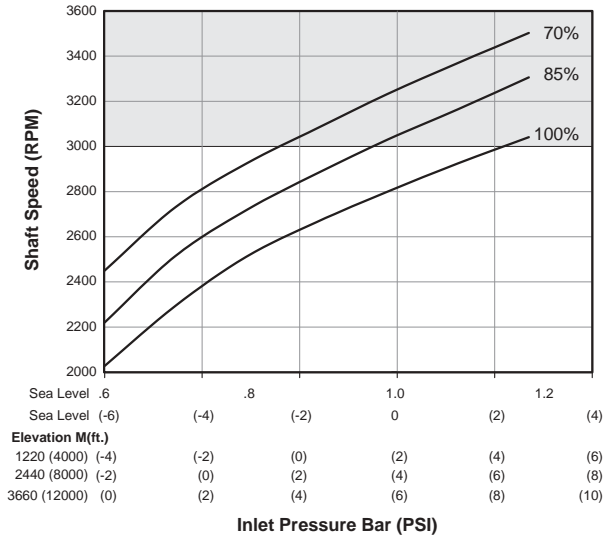

P2075 Inlet Characteristics

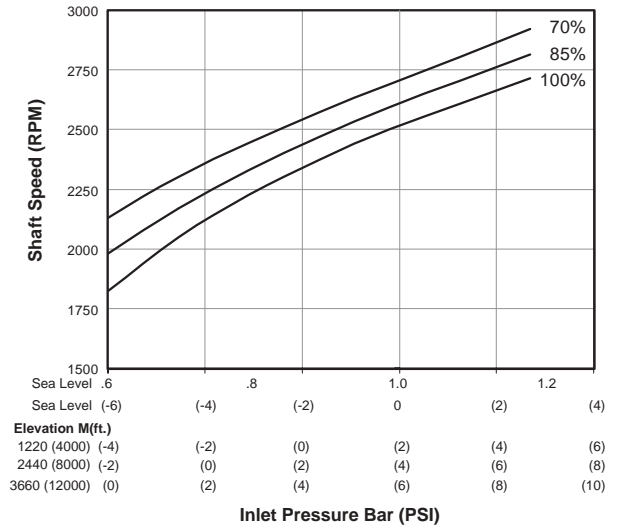

P2105 Inlet Characteristics

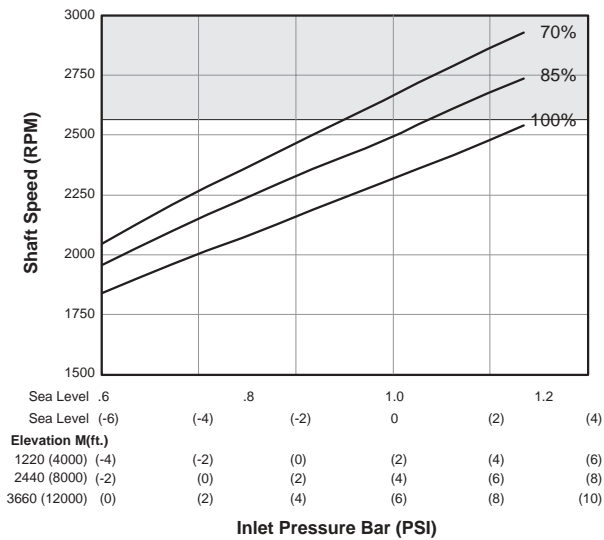

P2145 Inlet Characteristics

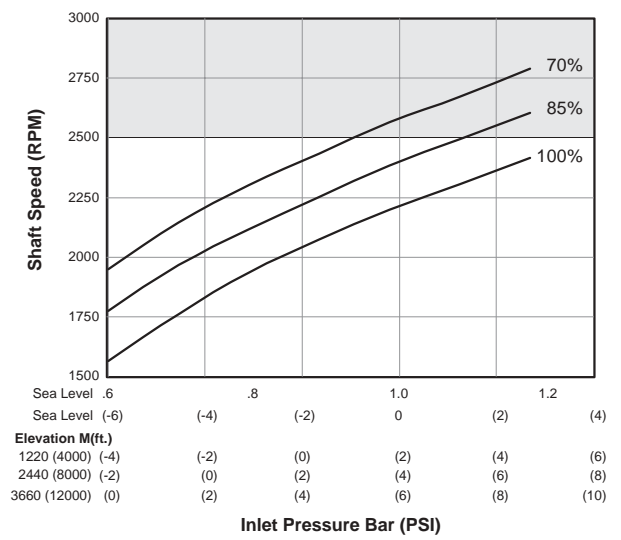

For operation at these speeds, please consult factory for approval.

Dimensional Data

Pump Installation - P2-060 Mounting Flange (side port)

Port Options	Drain Port	Inlet Gauge Port Outlet Gauge Port Signal Port
"A" Side - UNC	SAE-10 Straight Thread O-ring Port 7/8-14 UN Thread	SAE-4 Straight Thread O-ring Port 7/16-20 UN Thread
"B" Side - Metric	ISO 6149 Straight Thread O-ring Port M22 x 1.5 Thread	ISO 6149 Straight Thread O-ring Port M12 x 1.5 Thread

SAE B 2-BOLT MOUNTING FLANGE - DIAGONAL MOUNT

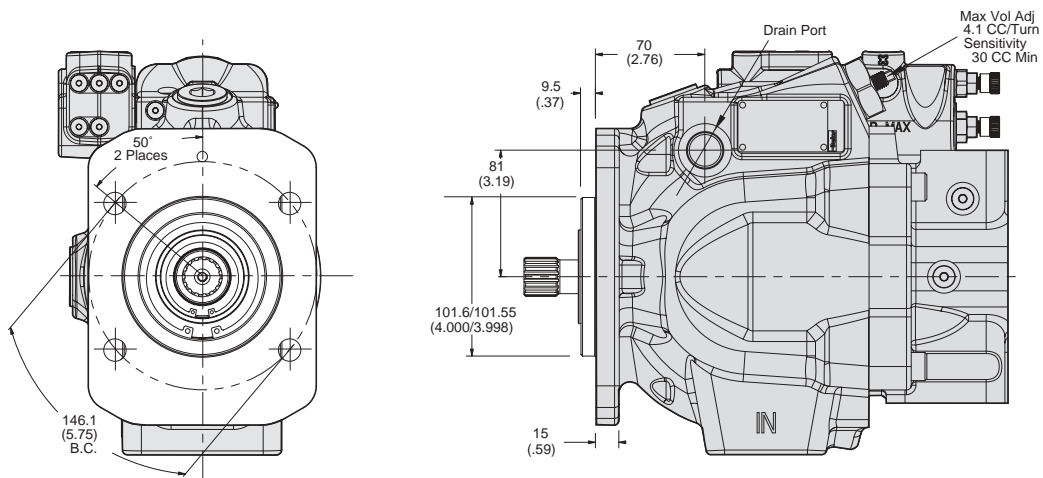

SAE C 4-BOLT MOUNTING FLANGE

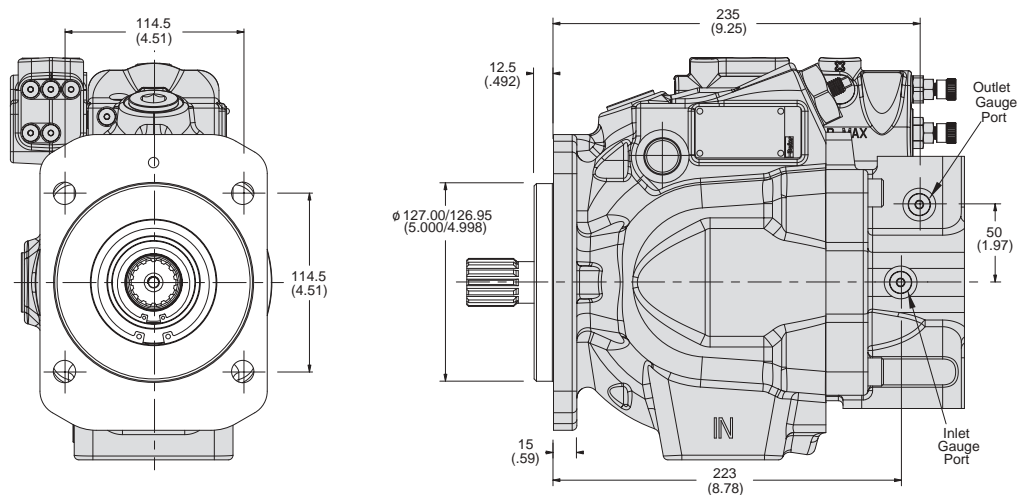

CCW Pump will have inlet and outlet gauge ports reversed.



Dimensional Data

Pump Installation - P2-060 Side Port

Port Options	Drain Port	Inlet Port	Outlet Port	Inlet Gauge Port Outlet Gauge Port Signal Port
"A" Side - UNC	SAE-12 Straight Thread O-ring Port 1-1/16-12 Thread	1/2-13 UN	7/16-14 UN	SAE-4 Straight Thread O-ring Port 7/16-20 UN Thread
"B" Side - Metric	ISO 6149 Straight Thread O-ring Port M27 x 2 Thread	M12 x 1.75	M12 x 1.75	ISO 6149 Straight Thread O-ring Port M12 x 1.5 Thread

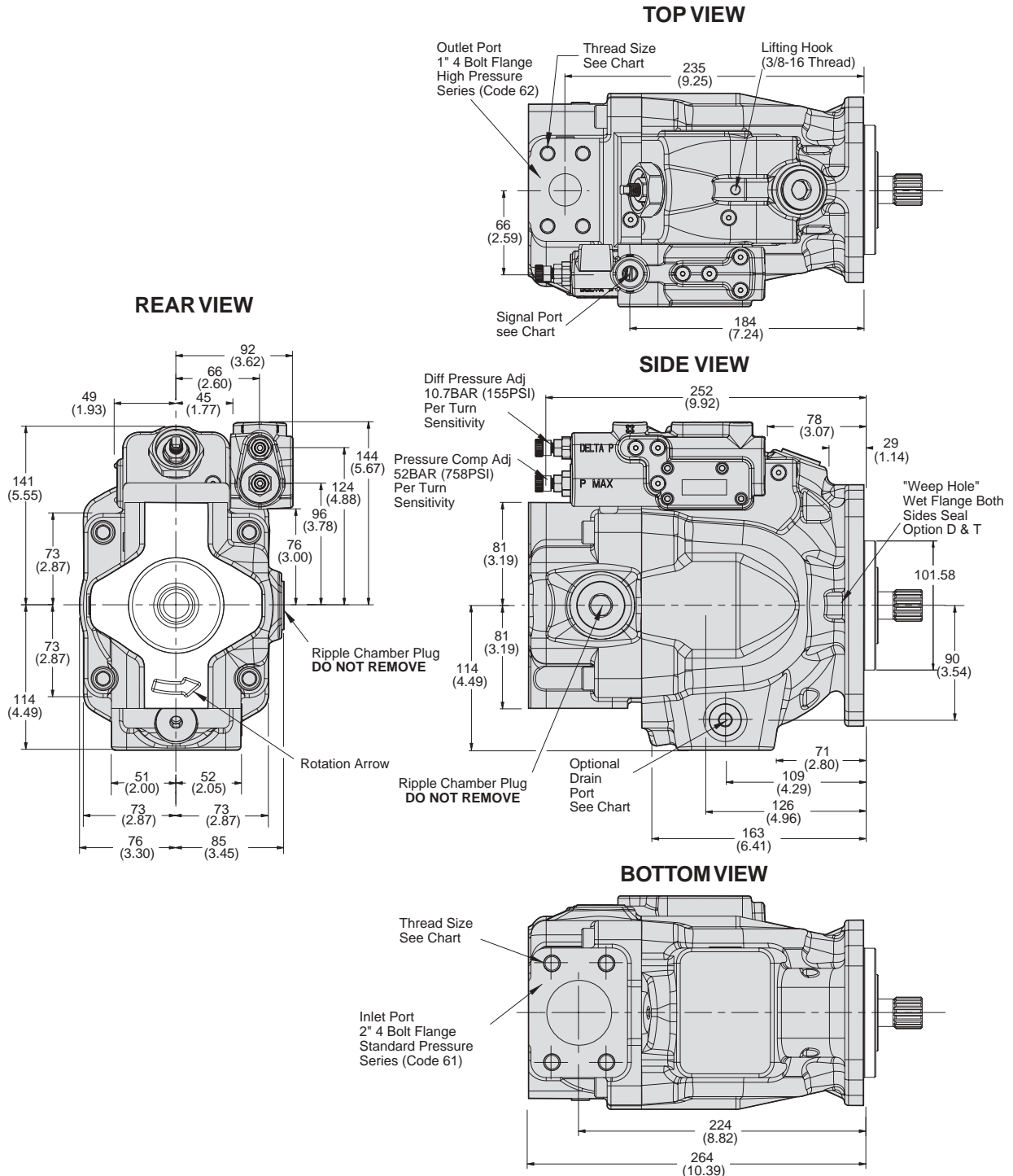

Dimensional Data

Pump Installation - P2-060 Mounting Flange (rear port)

SAE B 2-BOLT MOUNTING FLANGE - DIAGONAL MOUNT

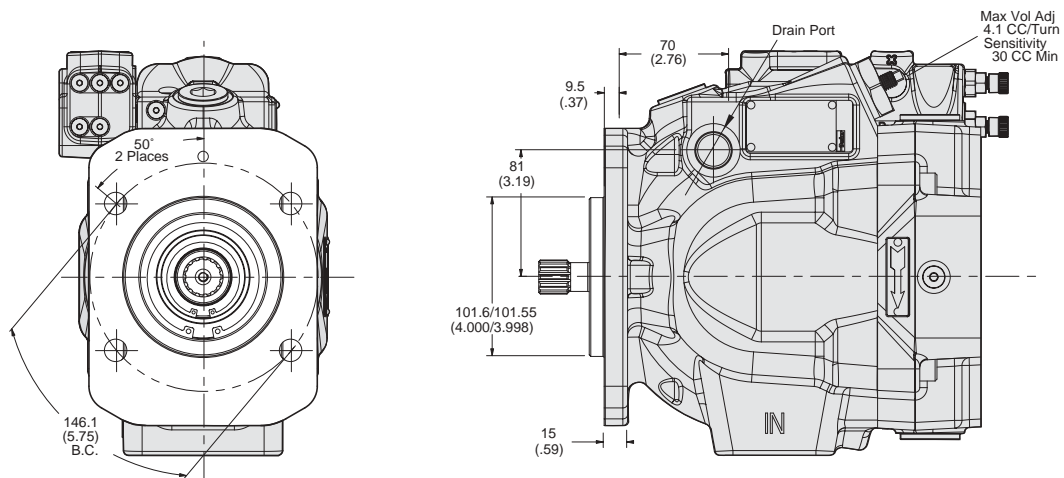

SAE C 4-BOLT MOUNTING FLANGE

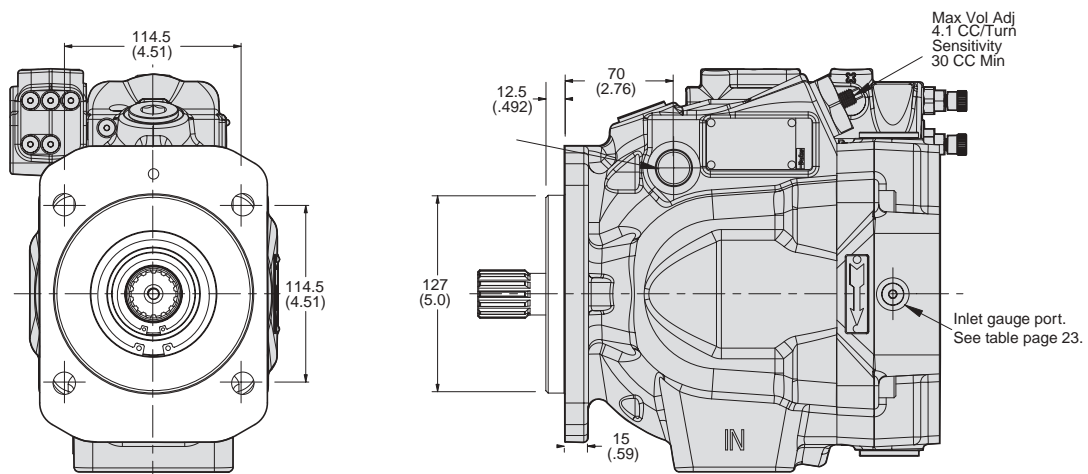

CCW Pump will have inlet and outlet gauge ports reversed. Does not include Ripple Chamber.

Dimensional Data

Pump Installation - P2-060 Rear Port

Port Options	Drain Port	Inlet Port	Outlet Port	Inlet Gauge Port Outlet Gauge Port Signal Port
"G" Rear - UNC	SAE-12 Straight Thread O-ring Port 1-1/16-12 Thread	1/2-13 UN	7/16-14 UN	SAE-4 Straight Thread O-ring Port 7/16-20 UN Thread
"H" Rear - Metric	ISO 6149 Straight Thread O-ring Port M27 x 2 Thread	M12 x 1.75	M12 x 1.75	ISO 6149 Straight Thread O-ring Port M12 x 1.5 Thread

TOP VIEW

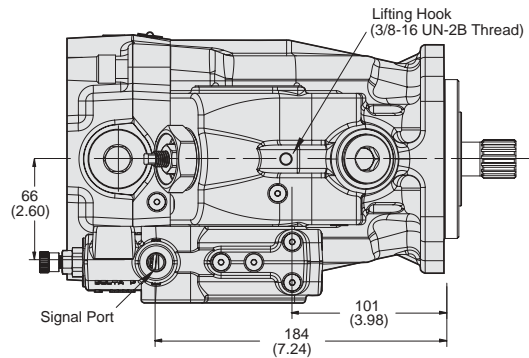

REAR VIEW

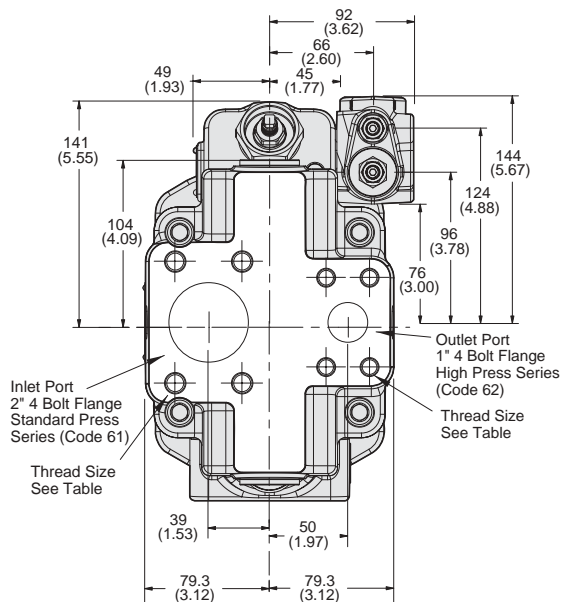

SIDE VIEW

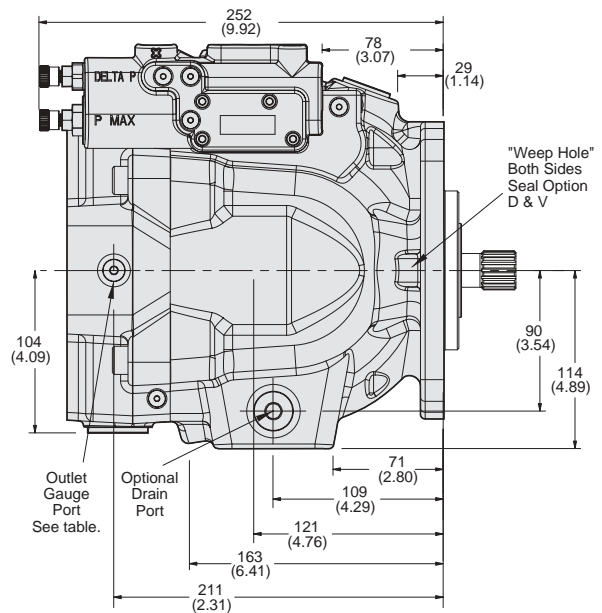

BOTTOM VIEW

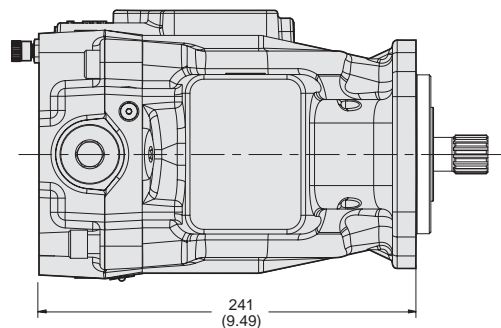

1. Pump shown is a clockwise rotation P2-060 series axial piston pump with load sense and maximum pressure.
2. CCW rotation pump will have inlet and outlet ports reversed.

Dimensional Data

Pump Installation - P2-060 Thru-Shaft Option

Thru-Shaft Option	A	B	C	D	E	F UNC	F Metric	G UNC	G Metric	Pump Weight
A1	264 (10.4)	82.625/ 82.575 (3.252/ 3.250)	106.38 (4.19)	N/A	SAE-A Spline 9 Tooth 16/32 Pitch	3/8-16 UNC-2B THD	M10 x 1.5 THD	N/A	N/A	36.2 kg (80 lbs)
B1	297 (11.7)	101.676/ 101.625 (4.002/ 4.000)	146.05 (5.75)	N/A	SAE-B Spline 13 Tooth 16/32 Pitch	1/2-13 UNC-2B THD	M12 x 1.75 THD	N/A	N/A	38.9 kg (86 lbs)
B2	297 (11.7)	101.676/ 101.625 (4.002/ 4.000)	146.05 (5.75)	N/A	SAE-BB Spline 15 Tooth 16/32 Pitch	1/2-13 UNC-2B THD	M12 x 1.75 THD	N/A	N/A	38.9 kg (86 lbs)
C1 C3	299 (11.8)	127.076/ 127.025 (5.002/ 5.000)	180.98 (7.125)	114.5 (4.58)	SAE-C Spline 14 Tooth 12/24 Pitch	5/8-11 UNC-2B THD	M16 x 2 THD	1/2-13 UNC-2B THD	M12 x 1.75 THD	40.2 kg (89 lbs)

A1 CONFIGURATION

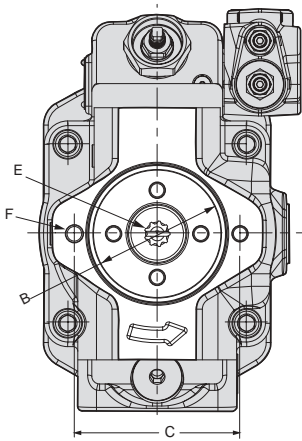

B1 & B2 CONFIGURATION

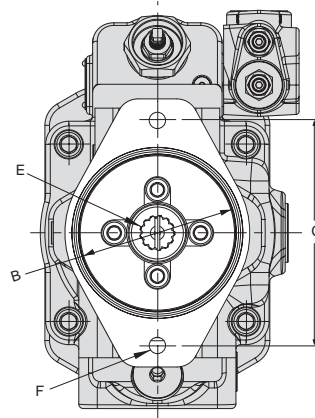

C1 & C3 CONFIGURATION

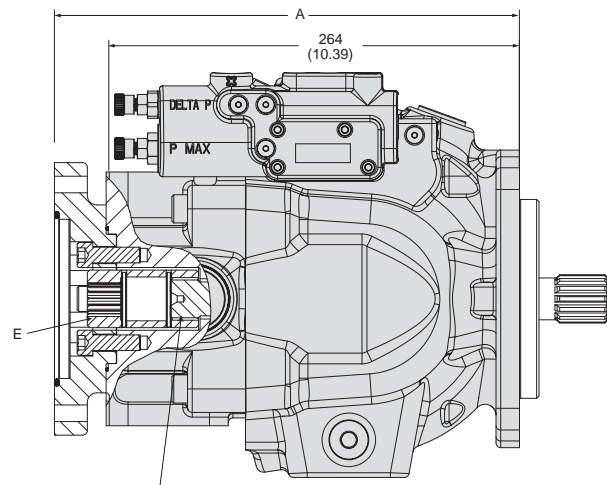
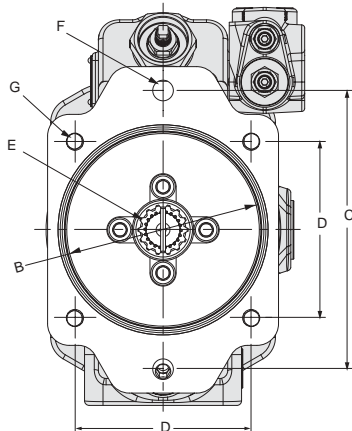

Max Thru-Drive Torque is 336 Nm (2980 lb in)

Dimensional Data

Pump Installation - P2-075 Mounting Flange

Port Options	Drain Port	Inlet Gauge Port Outlet Gauge Port
"A" Side - UNC	SAE-12 Straight Thread O-ring Port 1-1/16-12 UN Thread	SAE-4 Straight Thread O-ring Port 7/16-20 UN Thread
"B" Side - Metric	ISO 6149 Straight Thread O-ring Port M27 x 2 Thread	ISO 6149 Straight Thread O-ring Port M12 x 1.5 Thread

FLANGE MOUNTING DIMENSIONS - SIDE PORTED PUMP

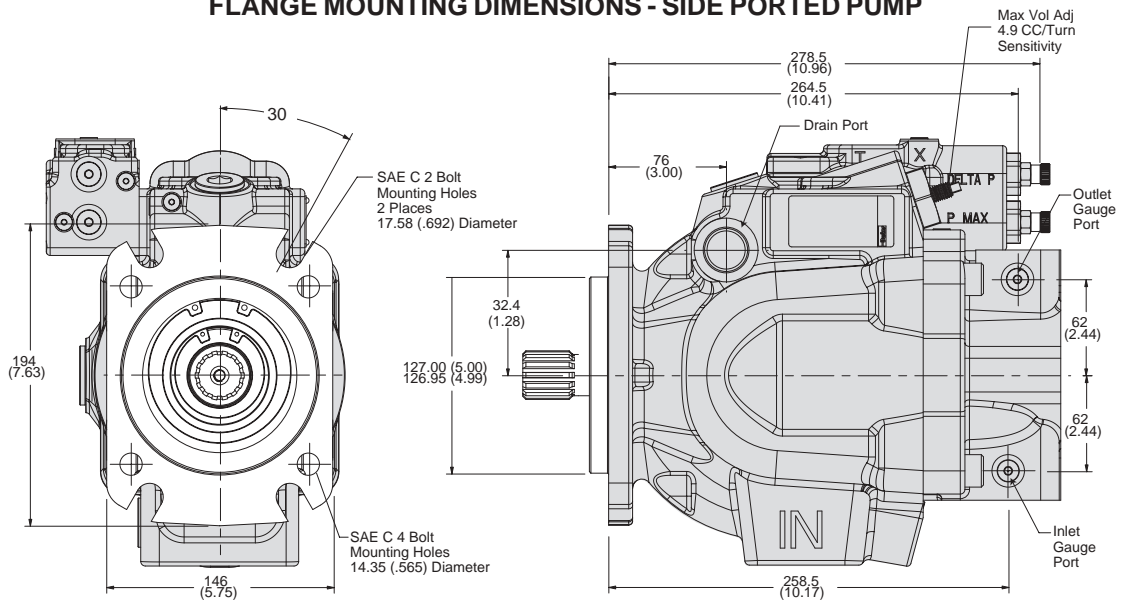

FLANGE MOUNTING DIMENSIONS - REAR PORTED PUMP

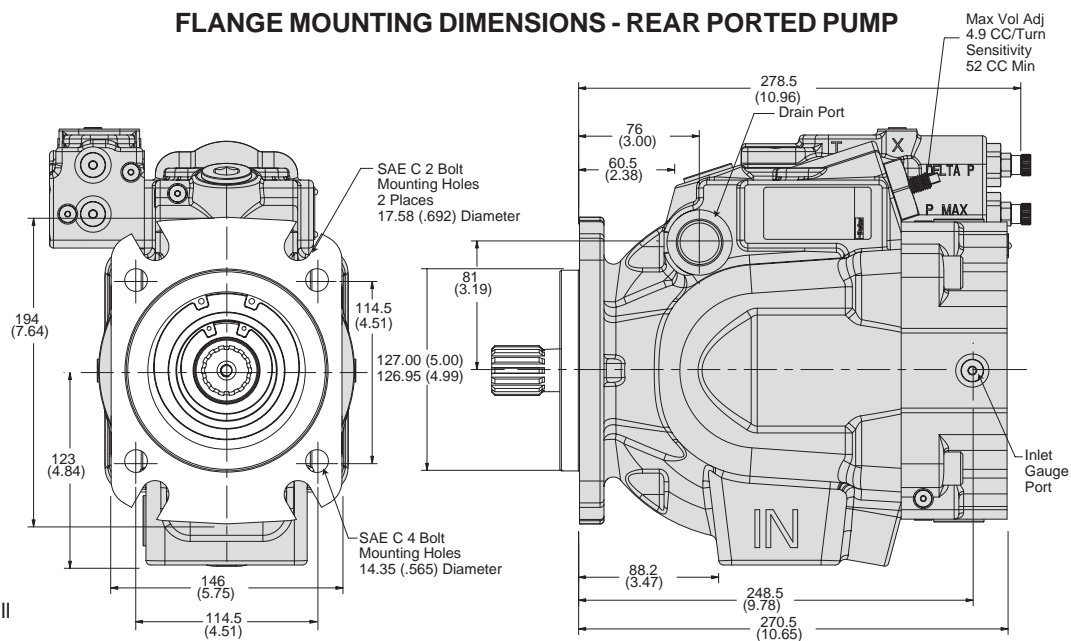

CCW Pump will have inlet and outlet gauge ports reversed.

Dimensional Data

Pump Installation - P2-075 Side Port

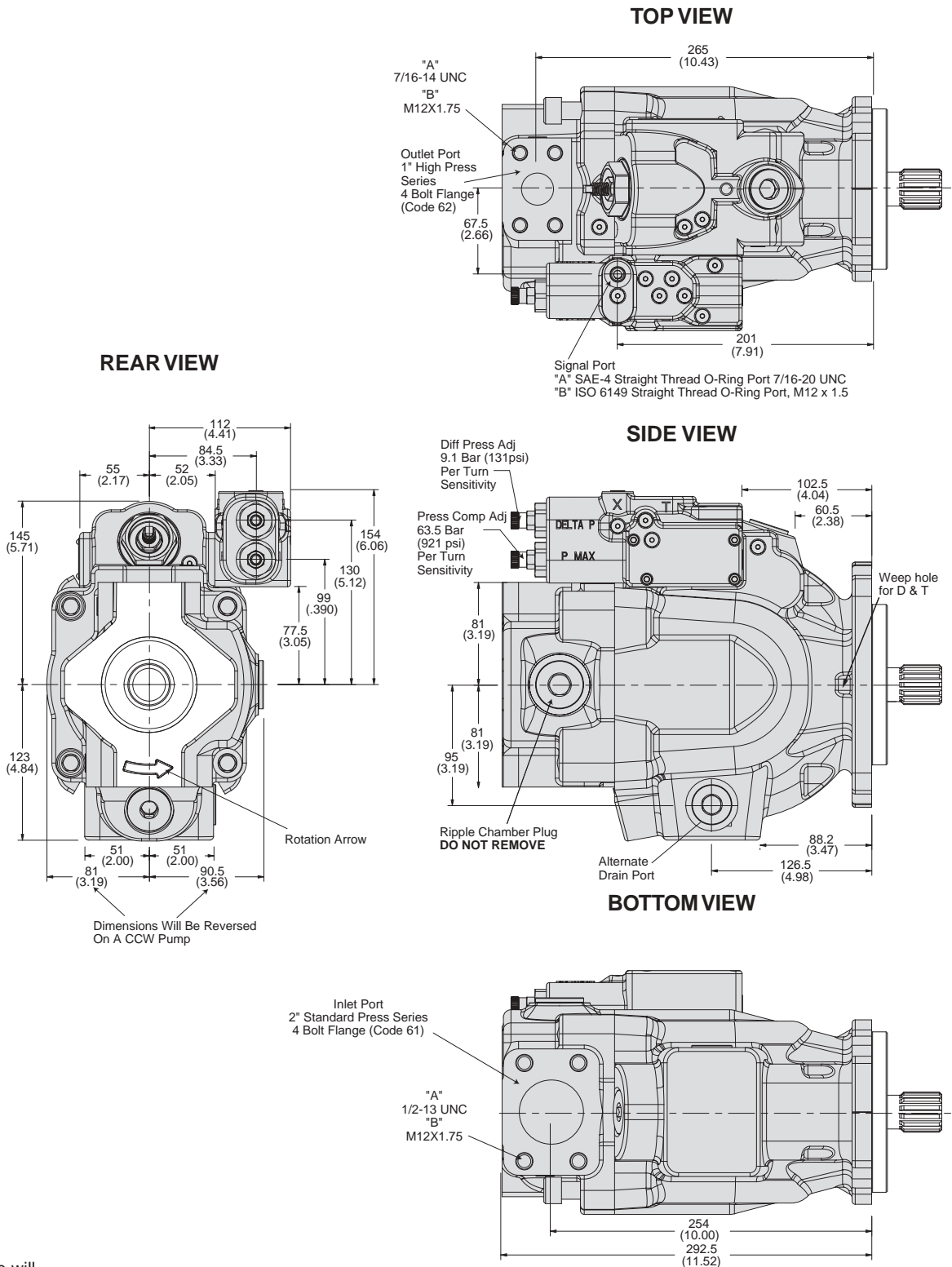

CCW Pump will have inlet and outlet gauge ports reversed.



Dimensional Data

Pump Installation - P2-075 Rear Port

Port Options	Drain Port	Inlet Port	Outlet Port	Inlet Gauge Port Outlet Gauge Port Signal Port
"G" Rear - UNC	SAE-12 Straight Thread O-ring Port 1-1/16-12 Thread	1/2-13 UN	7/16-14 UN	SAE-4 Straight Thread O-ring Port 7/16-20 UN Thread
"H" Rear - Metric	ISO 6149 Straight Thread O-ring Port M27 x 2 Thread	M12 x 1.75	M12 x 1.75	ISO 6149 Straight Thread O-ring Port M12 x 1.5 Thread

TOP VIEW

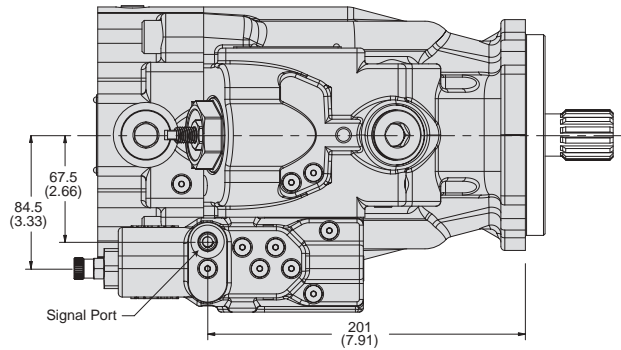

REAR VIEW

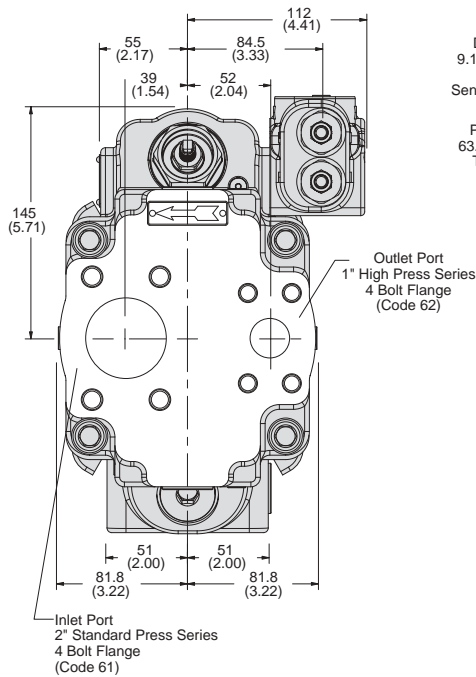

SIDE VIEW

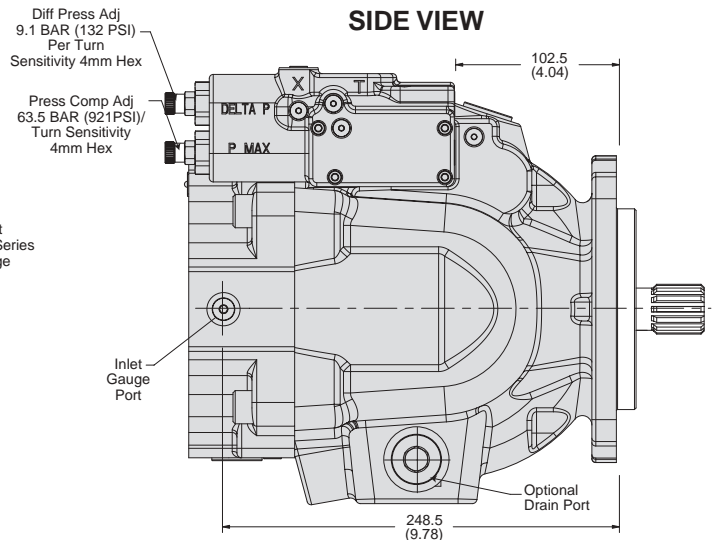

BOTTOM VIEW

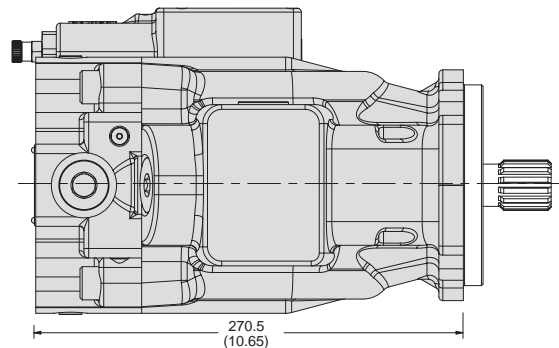

1. Pump shown is a clockwise rotation P2-075 series axial piston pump with load sense and maximum pressure.
2. CCW rotation pump will have inlet and outlet ports reversed.

Dimensional Data

Pump Installation - P2-075 Thru-Shaft Option

Thru-Shaft Option	A	B	C	D	E	F UNC	F Metric	G UNC	G Metric	Pump Weight
A1	292.5 (10.4)	82.625/ 82.575 (3.252/ 3.250)	106.38 (4.19)	N/A	SAE-A Spline 9 Tooth 16/32 Pitch	3/8-16 UNC-2B THD	M10 x 1.5 THD	N/A	N/A	44 kg (97 lbs)
B1	325.5 (11.7)	101.676/ 101.625 (4.002/ 4.000)	146.05 (5.75)	N/A	SAE-B Spline 13 Tooth 16/32 Pitch	1/2-13 UNC-2B THD	M12 x 1.75 THD	N/A	N/A	46.5 kg (102.5 lbs)
B2	325.5 (11.7)	101.676/ 101.625 (4.002/ 4.000)	146.05 (5.75)	N/A	SAE-BB Spline 15 Tooth 16/32 Pitch	1/2-13 UNC-2B THD	M12 x 1.75 THD	N/A	N/A	46.5 kg (102.5 lbs)
C1 C3	299 (11.8)	127.076/ 127.025 (5.002/ 5.000)	180.98 (7.125)	114.5 (4.58)	SAE-C Spline 14 Tooth 12/24 Pitch	5/8-11 UNC-2B THD	M16 x 2 THD	1/2-13 UNC-2B THD	M12 x 1.75 THD	48 kg (105.9 lbs)

A1 CONFIGURATION

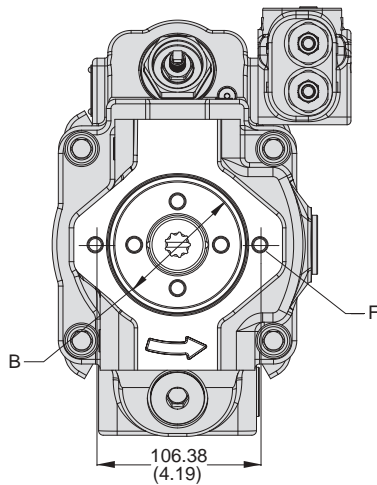

B1 & B2 CONFIGURATION

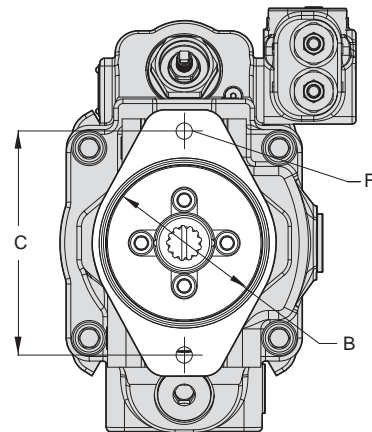

C1 & C3 CONFIGURATION

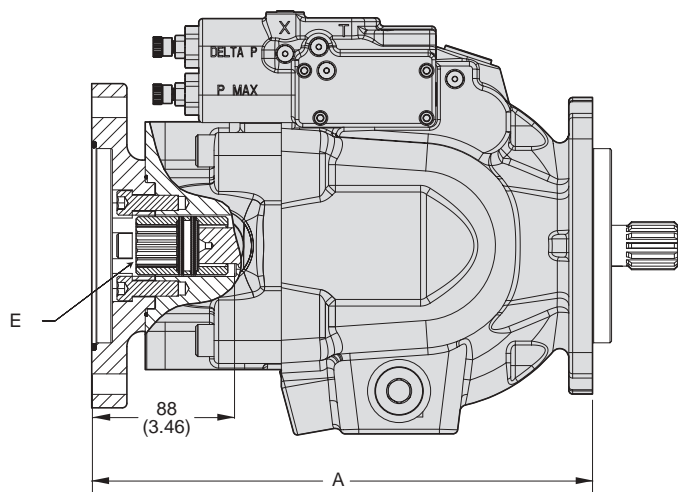
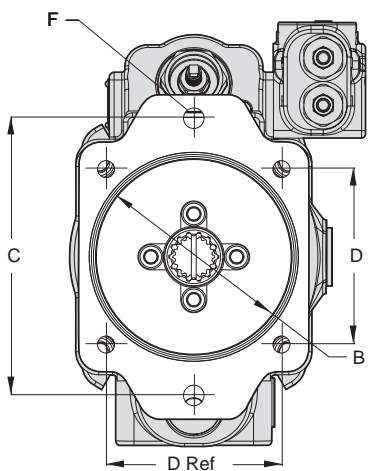

Max Thru-Drive Torque is 336 Nm (2973 lb in)

Pumps will be assembled with flange adapters as shown.
Options B1, B2, C1 and C3 can be rotated 90°.

Dimensional Data

Pump Installation - P2-105 Mounting Flange

Port Options	Drain Port	Inlet Gauge Port Outlet Gauge Port
"A" Side - UNC	SAE-12 Straight Thread O-ring Port 1-1/16-12 UN-2B	SAE-4 Straight Thread O-ring Port 7/16-20 UN Thread
"B" Side - Metric	ISO 6149 Straight Thread O-ring Port M27 x 2 Thread	ISO 6149 Straight Thread O-ring Port M12 x 1.5 Thread

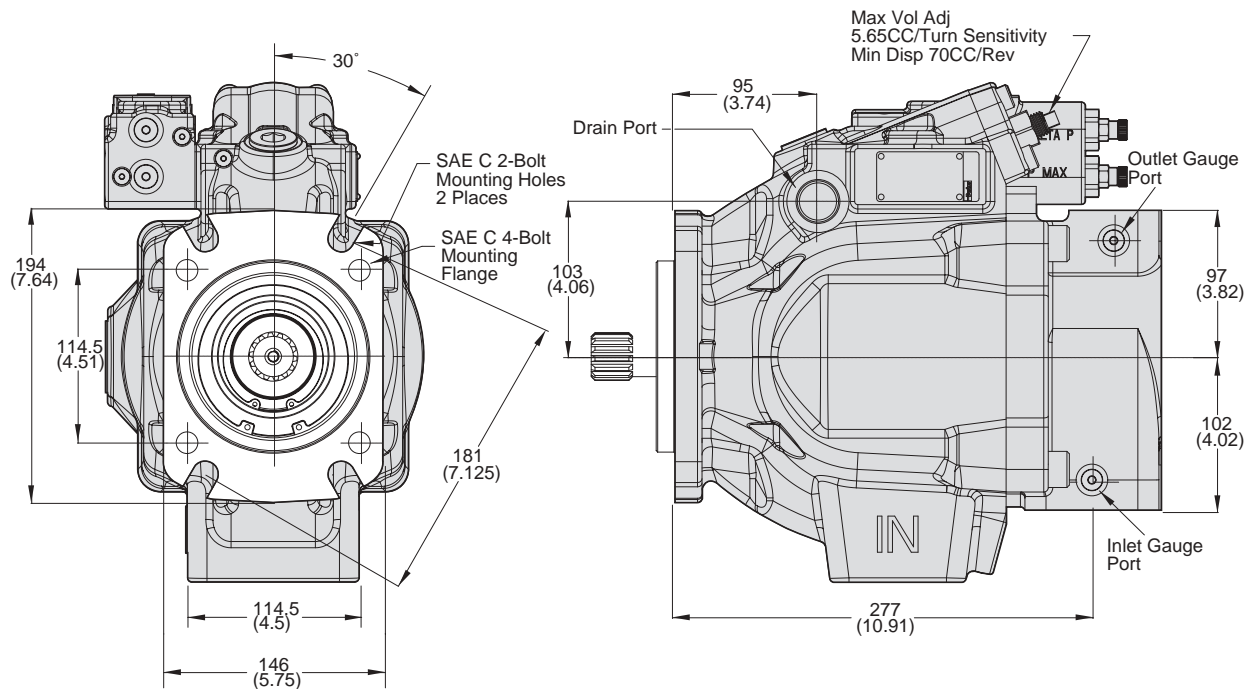

CCW Pump will have inlet and outlet gauge ports reversed.

Dimensional Data

Pump Installation - P2-105 Side Port

Port Options	Drain Port	Inlet Port	Outlet Port	Inlet Gauge Port Outlet Gauge Port Signal Port
"A" Side - UNC	SAE-12 Straight Thread O-ring Port 1-1/16-12 UN-2B	1/2-13 UN	1/2-13 UN	SAE-4 Straight Thread O-ring Port 7/16-20 UN Thread
"B" Side - Metric	ISO 6149 Straight Thread O-ring Port M27 x 2 Thread	M12 x 1.75	M12 x 1.75	ISO 6149 Straight Thread O-ring Port M12 x 1.5 Thread

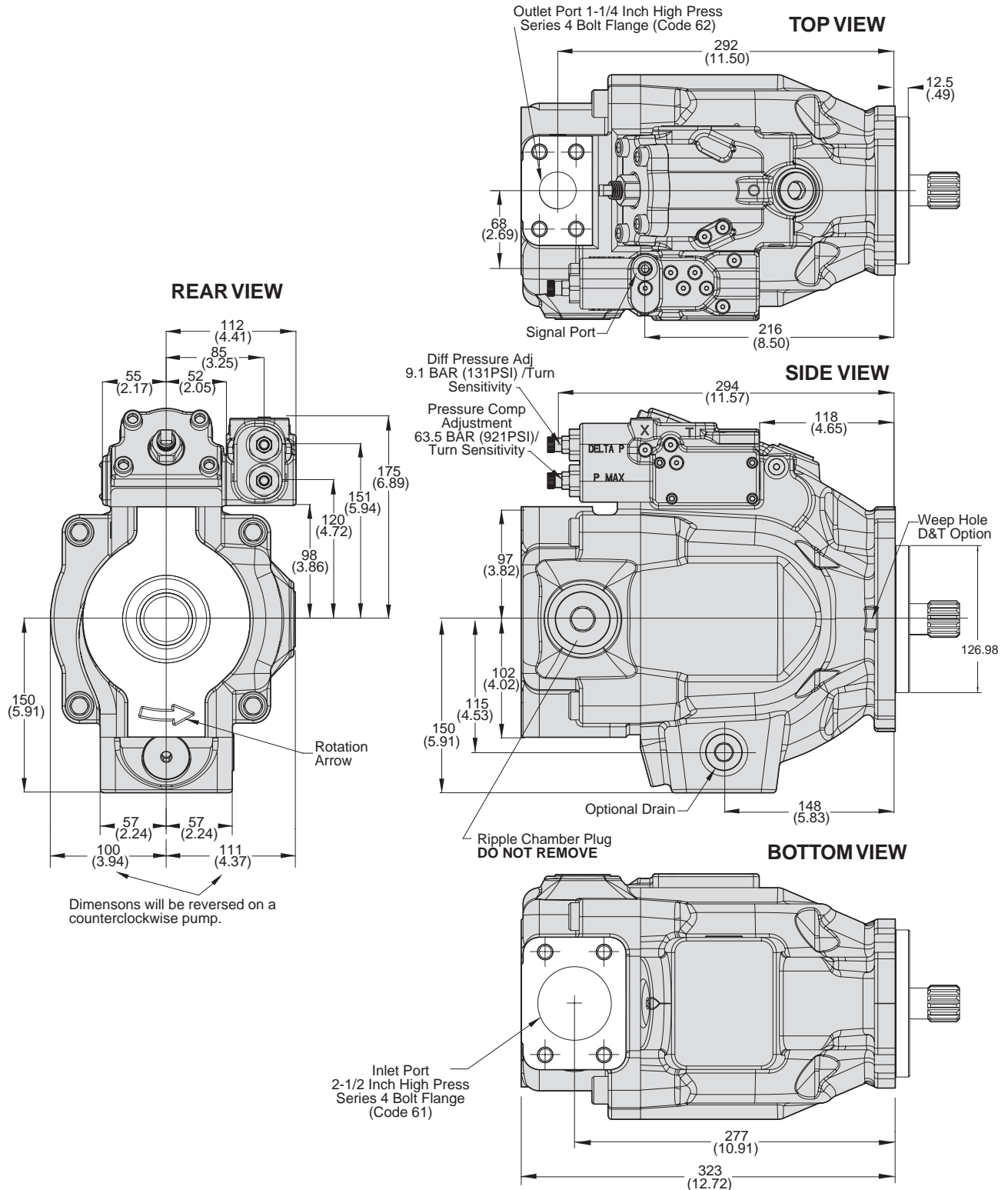

Dimensional Data

Pump Installation - P2-105 Thru-Shaft Option

Thru-Shaft Option	A	B	C	D	E	F UNC	F Metric	G UNC	G Metric	Pump Weight
A1	323 (12.72)	∅ 82.626/ 82.575 (3.252/ 3.250)	106.3 (4.19)	N/A	SAE-A Spline 9 Tooth 16/32 Pitch	1/2-13 UNC-2B THD	M10 x 1.5 THD	N/A	N/A	61 (134)
B1	356 (14.02)	∅ 101.676/ 101.625 (4.002/ 4.001)	146.1 (5.75)	N/A	SAE-B Spline 13 Tooth 16/32 Pitch	1/2-13 UNC-2B THD	M12 x 1.75 THD	N/A	N/A	64 (140)
B2	356 (14.02)	∅ 101.676/ 101.625 (4.002/ 4.001)	146.1 (5.75)	N/A	SAE-BB Spline 15 Tooth 16/32 Pitch	1/2-13 UNC-2B THD	M12 x 1.75 THD	N/A	N/A	64 (140)
C1	358 (14.09)	∅ 127.075/ 127.025 (5.003/ 5.001)	181 (7.13)	114.5	SAE-C Spline 14 Tooth 12/24 Pitch	1/2-13 UNC-2B THD	M12 x 1.75 THD	5/8-11 UNC-2B THD	M16 x 2 THD	65 (143)
C3	358 (14.09)	∅ 127.075/ 127.025 (5.003/ 5.001)	181 (7.13)	114.5	SAE-C Spline 14 Tooth 12/24 Pitch	1/2-13 UNC-2B THD	M12 x 1.75 THD	5/8-11 UNC-2B THD	M16 x 2 THD	65 (143)

* All shaft Couplings 30 Degrees Involute Spline Flat Root Side Fit

*** Maximum Thru Drive Capability is Limited to 587Nm (5195 lb in)

A1 CONFIGURATION

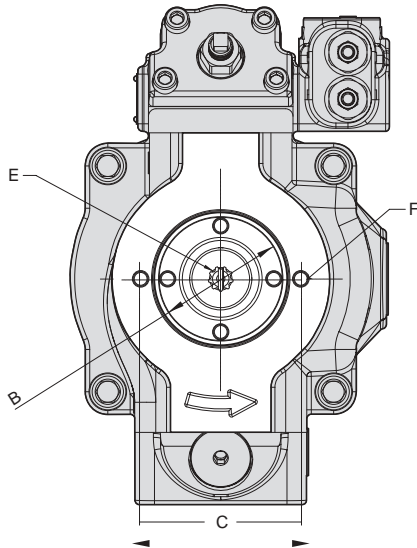

B1 & B2 CONFIGURATION

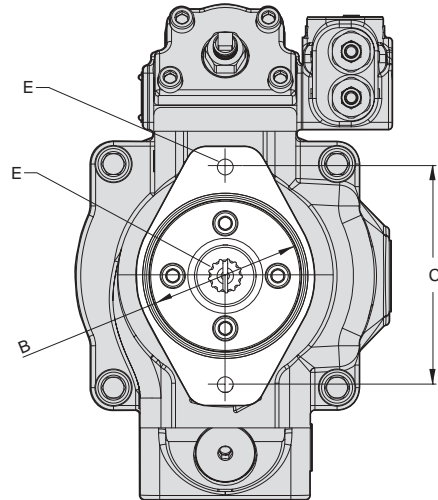

C1 & C3 CONFIGURATION

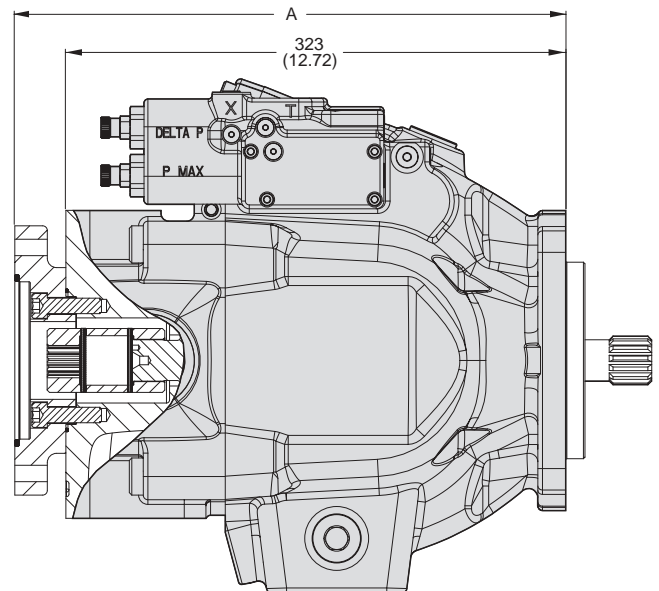
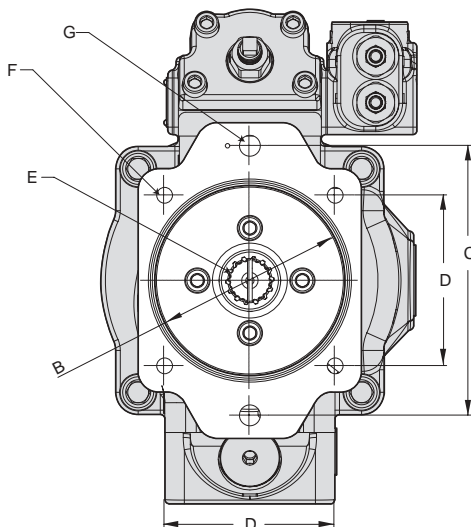

Dimensional Data

Pump Installation - P2-145 Mounting Flange

Port Options	Drain Port	Inlet Gauge Port Outlet Gauge Port
"A" Side - UNC	SAE-12 Straight Thread O-ring Port 1-1/16-12 UN Thread	SAE-4 Straight Thread O-ring Port 7/16-20 UN Thread
"B" Side - Metric	ISO 6149 Straight Thread O-ring Port M27 x 1.75 Thread	ISO 6149 Straight Thread O-ring Port M12 x 1.5 Thread

SAE D 4-BOLT MOUNTING FLANGE

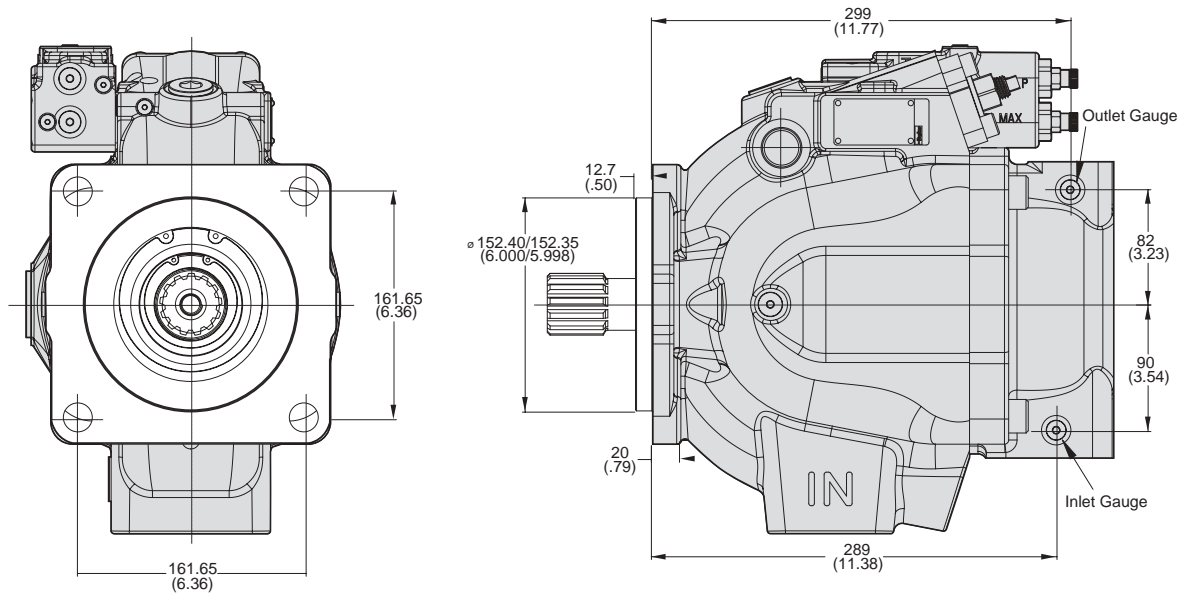

SAE C 2-BOLT MOUNTING FLANGE

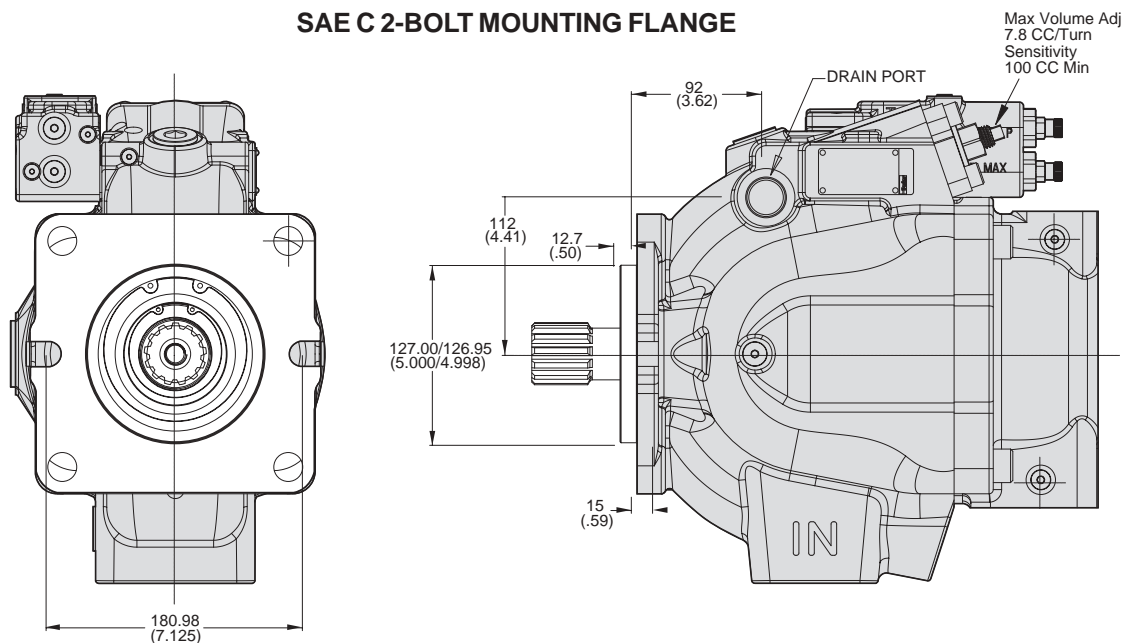

CCW Pump will have inlet and outlet gauge ports reversed.

Dimensional Data

Pump Installation - P2-145 Side Port

Port Options	Drain Port	Inlet Port	Outlet Port	Inlet Gauge Port Outlet Gauge Port Signal Port
"A" Side - UNC	SAE-12 Straight Thread O-ring Port 1-1/16-12 UN-2B	1/2-13 UN	1/2-13 UN	SAE-4 Straight Thread O-ring Port 7/16-20 UN Thread
"B" Side - Metric	ISO 6149 Straight Thread O-ring Port M27 x 2 Thread	M12 x 1.75	M12 x 1.75	ISO 6149 Straight Thread O-ring Port M12 x 1.5 Thread

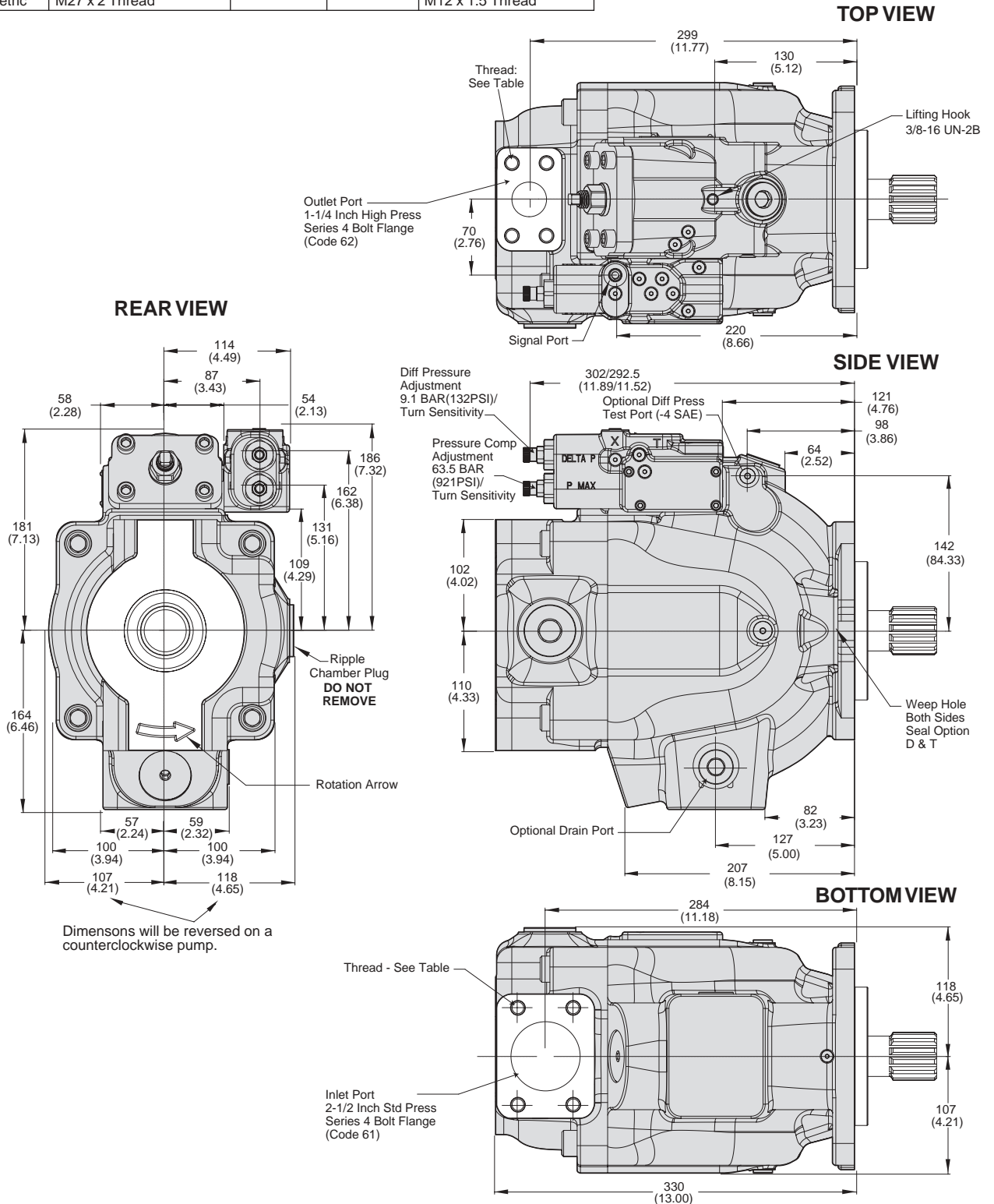

Dimensional Data

Pump Installation - P2-145 Thru-Shaft Option

Thru-Shaft Option	A	B	C	D	E	F UNC	F Metric	G UNC	G Metric	Pump Weight
A1	329.5 (13.0)	∅ 82.626/ 82.575 (3.252/ 3.250)	106.38 (4.19)	N/A	SAE-A Spline 9 Tooth 16/32 Pitch	3/8-16 UNC-2B THD	M10 x 1.5 THD	N/A	N/A	79.8 (176)
B1	362.5 (14.27)	∅ 101.676/ 101.625 (4.002/ 4.001)	146.05 (5.75)	N/A	SAE-B Spline 13 Tooth 16/32 Pitch	1/2-13 UNC-2B THD	M12 x 1.75 THD	N/A	N/A	82.6 (182)
B2	362.5 (14.27)	∅ 101.676/ 101.625 (4.002/ 4.001)	146.05 (5.75)	N/A	SAE-BB Spline 15 Tooth 16/32 Pitch	1/2-13 UNC-2B THD	M12 x 1.75 THD	N/A	N/A	82.6 (182)
C1	364.5 (14.35)	∅ 127.075/ 127.025 (5.003/ 5.001)	180.98 (7.13)	N/A	SAE-C Spline 14 Tooth 12/24 Pitch	5/8-11 UNC-2B THD	M16 x 2 THD	1/2-13 UNC-2B THD	M12 x 1.75 THD	83.9 (185)
C2	364.5 (14.35)	∅ 127.075/ 127.025 (5.003/ 5.001)	180.98 (7.13)	N/A	SAE-C Spline 14 Tooth 12/24 Pitch	5/8-11 UNC-2B THD	M16 x 2 THD	1/2-13 UNC-2B THD	M12 x 1.75 THD	83.9 (185)
C3	364.5 (14.35)	∅ 127.075/ 127.025 (5.003/ 5.001)	180.98 (7.13)	114.5	SAE-C Spline 14 Tooth 12/24 Pitch	5/8-11 UNC-2B THD	M16 x 2 THD	1/2-13 UNC-2B THD	M12 x 1.75 THD	83.9 (185)
C4	364.5 (14.35)	∅ 127.075/ 127.025 (5.003/ 5.001)	180.98 (7.13)	114.5	SAE-CC Spline 17 Tooth 12/24 Pitch	5/8-11 UNC-2B THD	M16 x 2 THD	1/2-13 UNC-2B THD	M12 x 1.75 THD	83.9 (185)
D3	375 (14.76)	∅ 152.475/ 152.425 (6.003/ 6.001)	N/A	161.65	SAE-D Spline 13 Tooth 8/16 Pitch	N/A	N/A	3/4-10 UNC-2B THD	M16 x 2 THD	88.0 (194)

*** Maximum Thru Drive Capability is Limited to 1217Nm (10777 lb in)

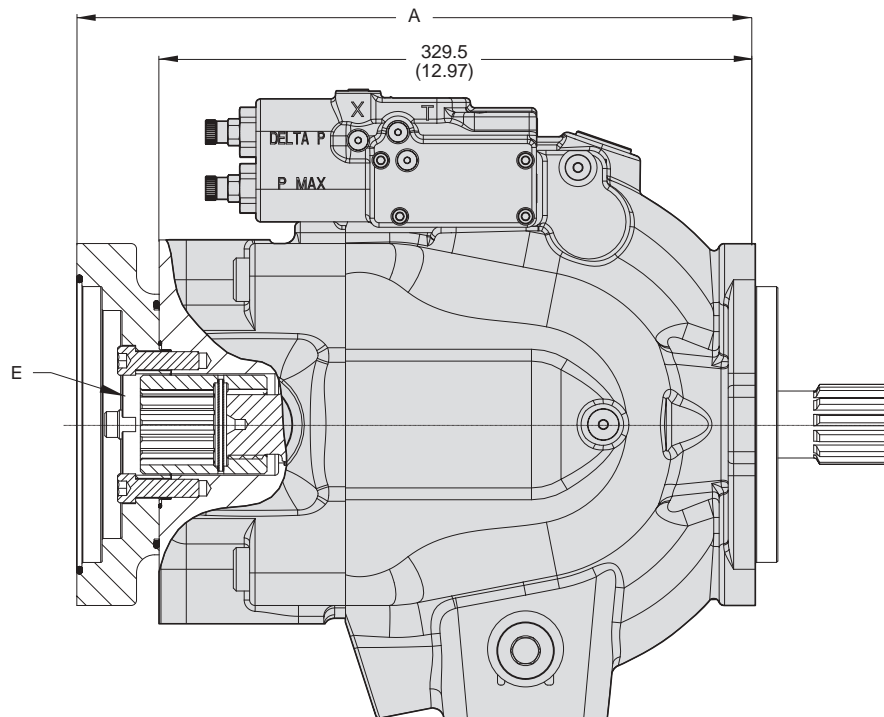

Dimensional Data

Pump Installation - P2-145 Thru-Shaft Option

A1 CONFIGURATION

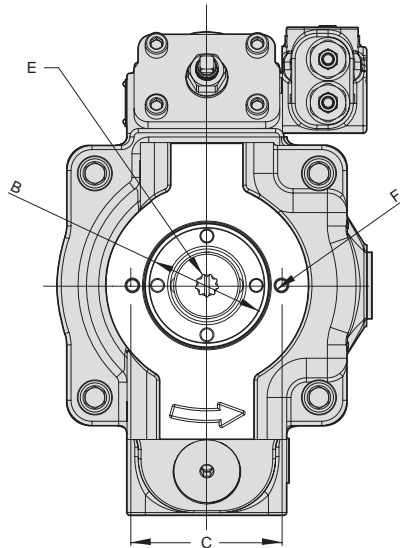

B1 & B2 CONFIGURATION

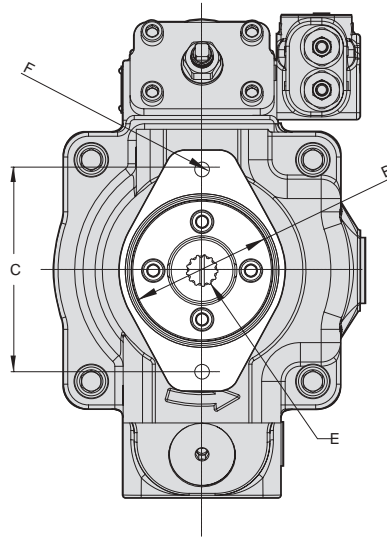

C1, C2, C3 & C4 CONFIGURATION

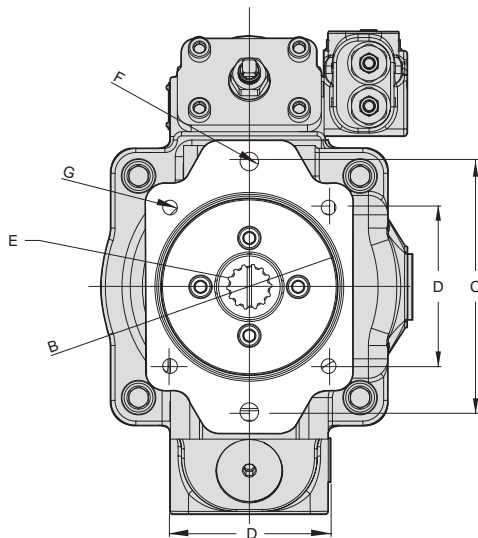

D3 CONFIGURATION

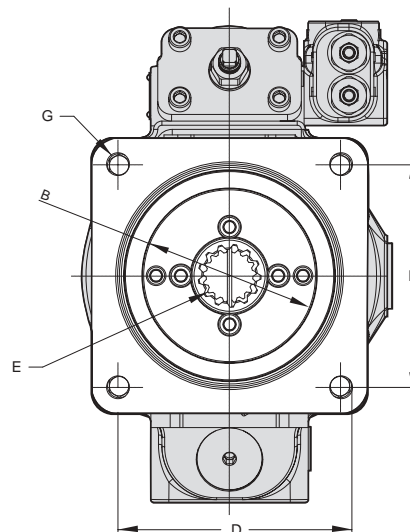

Dimensional Data

Pump Installation- P2 Shaft Options

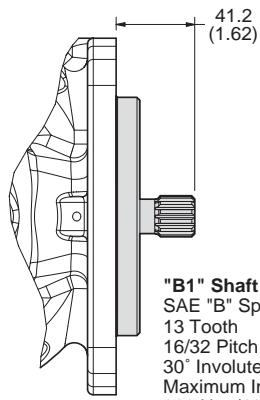

"B1" Shaft Option
SAE "B" Spline
13 Tooth
16/32 Pitch
30° Involute Spline
Maximum Input Torque:
209 Nm (1852 lb in)

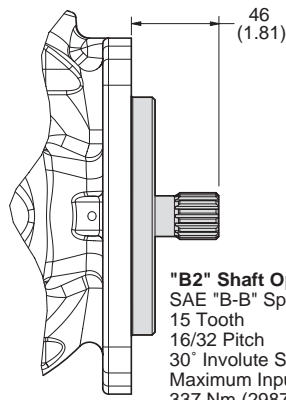

"B2" Shaft Option
SAE "B-B" Spline
15 Tooth
16/32 Pitch
30° Involute Spline
Maximum Input Torque:
337 Nm (2987 lb in)

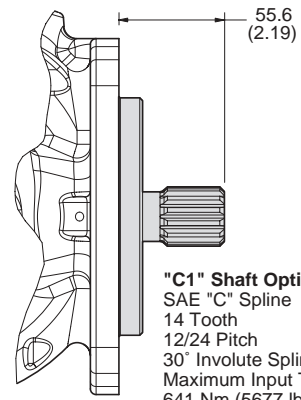

"C1" Shaft Option
SAE "C" Spline
14 Tooth
12/24 Pitch
30° Involute Spline
Maximum Input Torque:
641 Nm (5677 lb in)

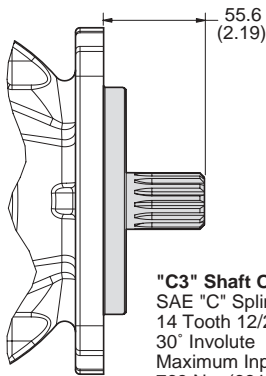

"C3" Shaft Option
SAE "C" Spline No Undercut
14 Tooth 12/24 Pitch
30° Involute
Maximum Input Torque:
769 Nm (6812 lb in)

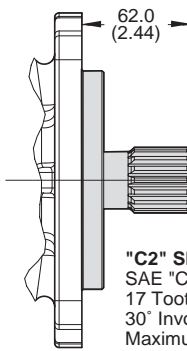

"C2" Shaft Option
SAE "CC" Spline
17 Tooth 12/24 Pitch
30° Involute
Maximum Input Torque:
1217 Nm (10777 lb in)

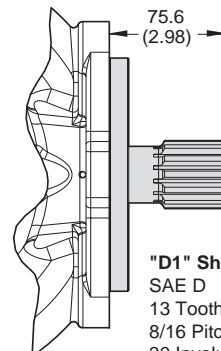

"D1" Shaft Option
SAE D
13 Tooth
8/16 Pitch
30 Involute Spline
Maximum Input Torque:
1701 Nm (15057 lb in)

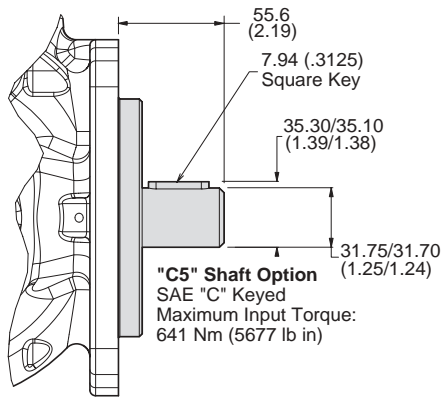

"C5" Shaft Option
SAE "C" Keyed
Maximum Input Torque:
641 Nm (5677 lb in)

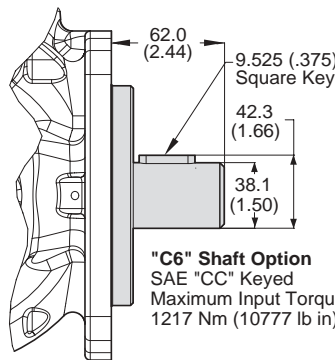

"C6" Shaft Option
SAE "CC" Keyed
Maximum Input Torque:
1217 Nm (10777 lb in)

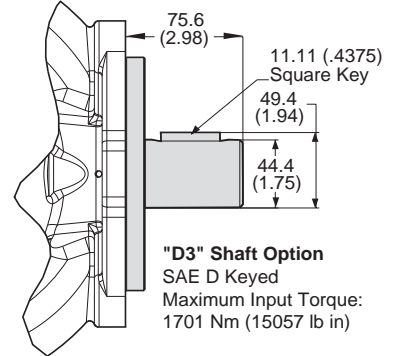

"D3" Shaft Option
SAE D Keyed
Maximum Input Torque:
1701 Nm (15057 lb in)

Torque Control
Options "TA", "TB", "TC" & "TD"
200 Nm (1770 lb in) Per Turn
Approximate Sensitivity

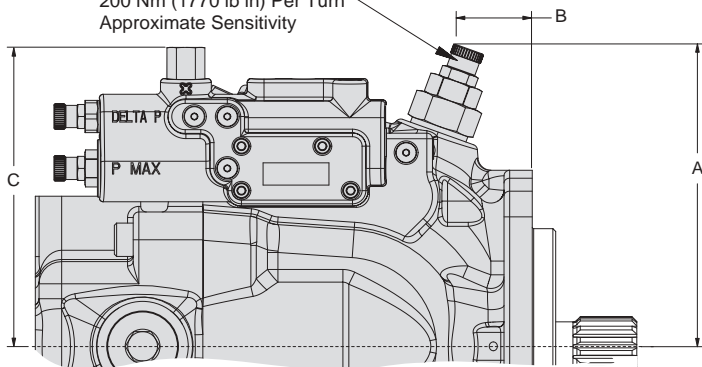

	P2 060	P2075	P2105	P2145
A	163 (6.42)	171 (6.73)	190 (7.48)	202 (7.95)
B	33.7 (1.33)	69 (2.72)	69 (2.72)	69 (2.72)
C	161 (6.34)	154 (6.06)	175 (6.89)	186 (7.32)

Performance Data

P3 Series Typical Torque Control Characteristics

Fluid: Mineral oil ISO VG 32 @ 40° C

Inlet pressure: 1.0 Bar (14.5 PSI) (Absolute) measured at inlet port.

**P3075 20 - 60% Torque
1800 RPM**

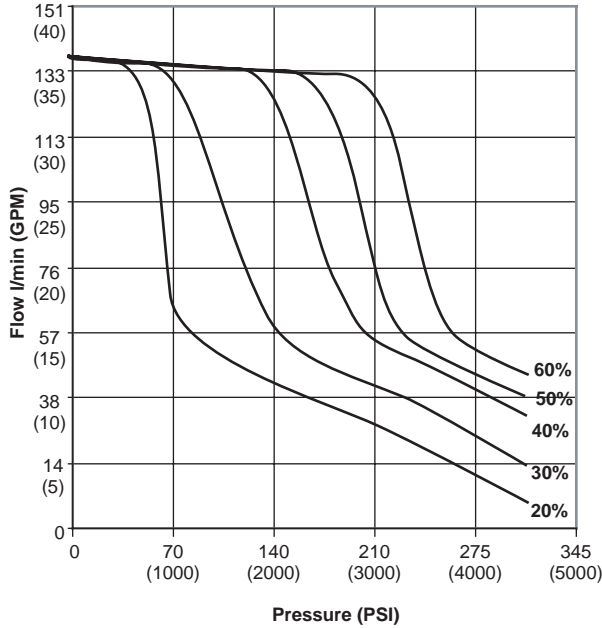

**P3075 50 - 90% Torque
1800 RPM**

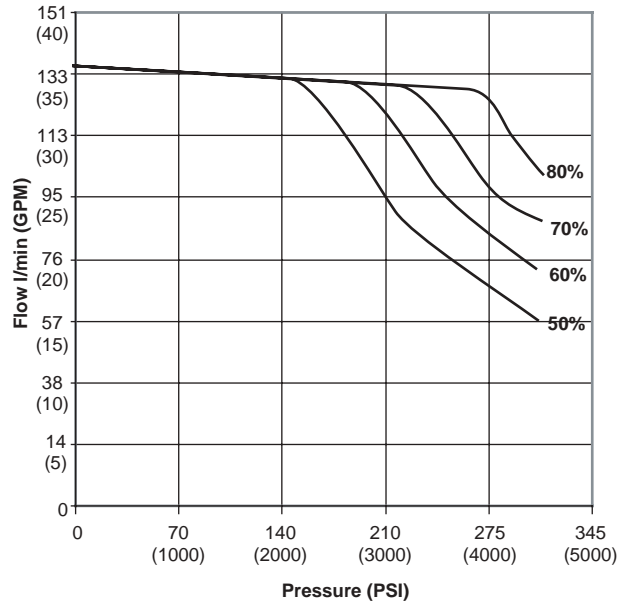

**P3105 20 - 60% Torque
1800 RPM**

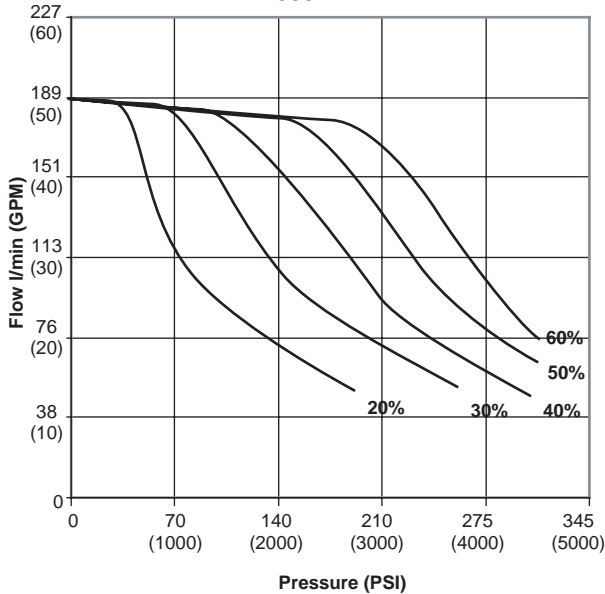

**P3105 50 - 90% Torque
1800 RPM**

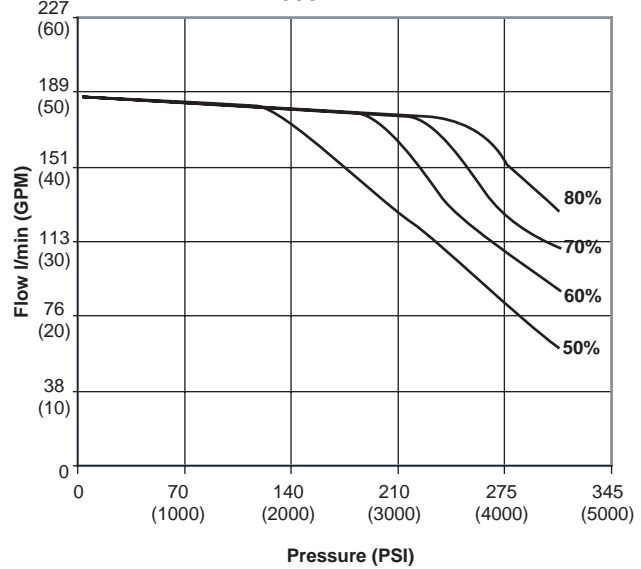

Performance Data

P3 Series Typical Torque Control Characteristics

Fluid: Mineral oil ISO VG 32 @ 40° C

Inlet pressure: 1.0 Bar (14.5 PSI) (Absolute) measured at inlet port.

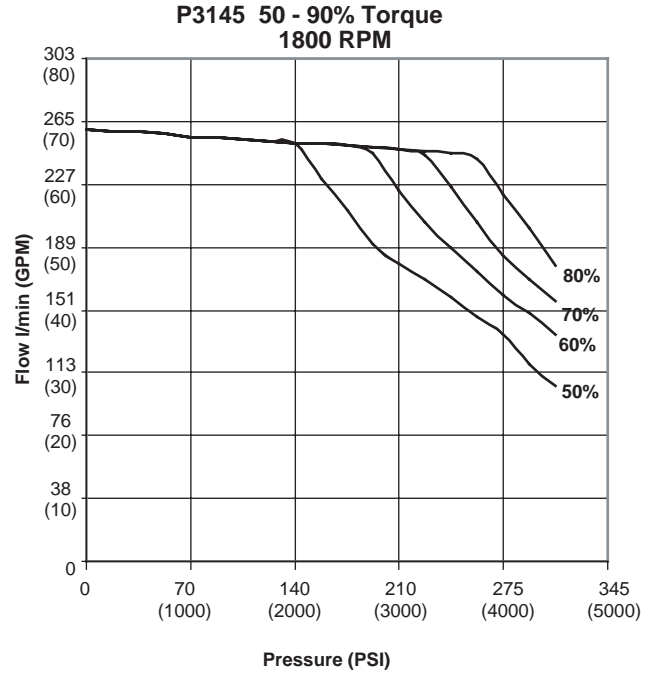
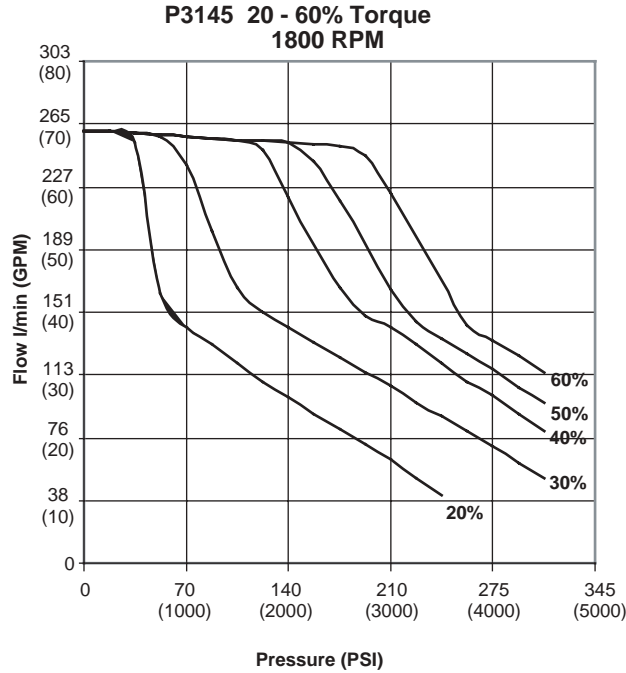

Performance Data

P3 Series Typical Noise Characteristics at Max Displacement

(These are anechoic sound pressure readings.)

Fluid: Mineral oil ISO VG 32 @ 40° C

Inlet pressure: 1.0 Bar (14.5 PSI) (Absolute) measured at inlet port.

P3075 Noise Characteristics at Max Displacement

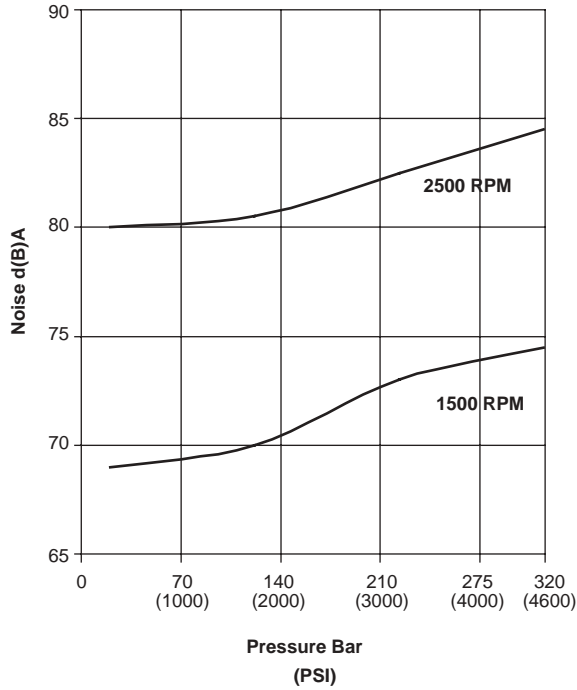

P3145 Noise Characteristics at Max Displacement

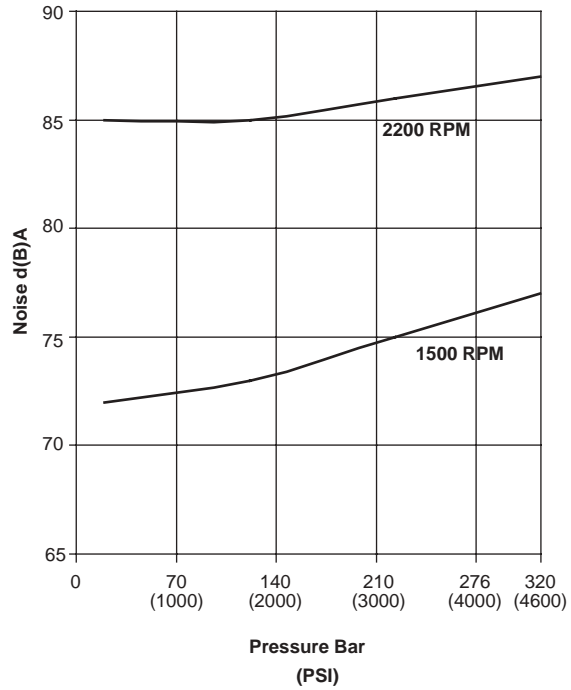

P3105 Noise Characteristics at Max Displacement

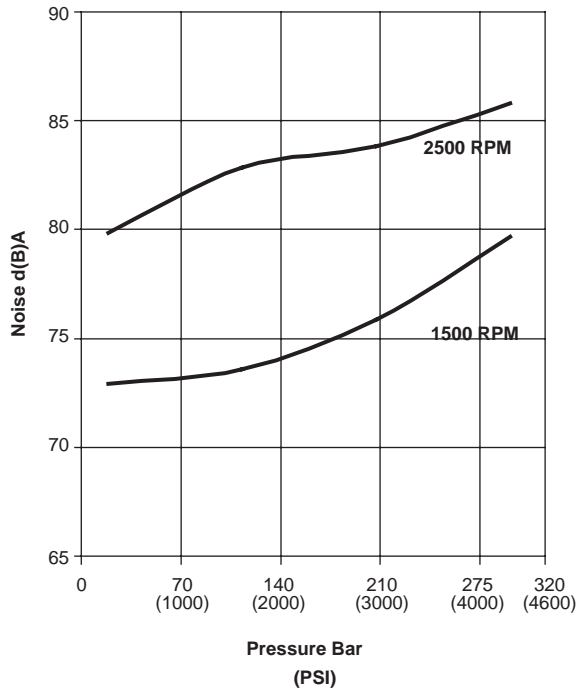

Performance Data

P3 Series Typical Drive Power at Full Displacement

Fluid: Mineral oil ISO VG 32 @ 40° C

Inlet pressure: 1.0 Bar (14.5 PSI) (Absolute) measured at inlet port.

P3075 Input Power - Full Stroke

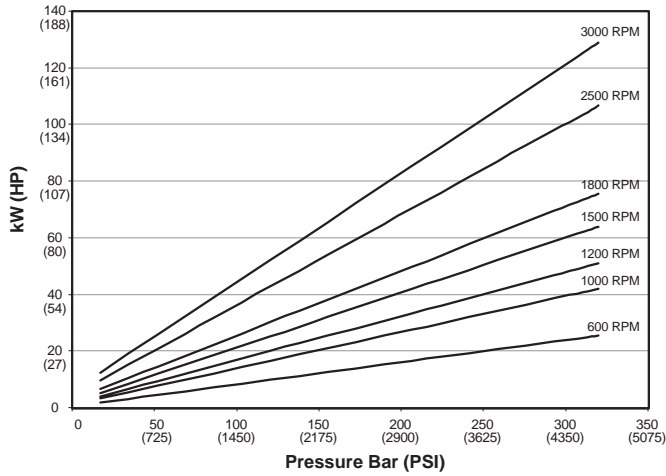

P3105 Input Power - Full Stroke

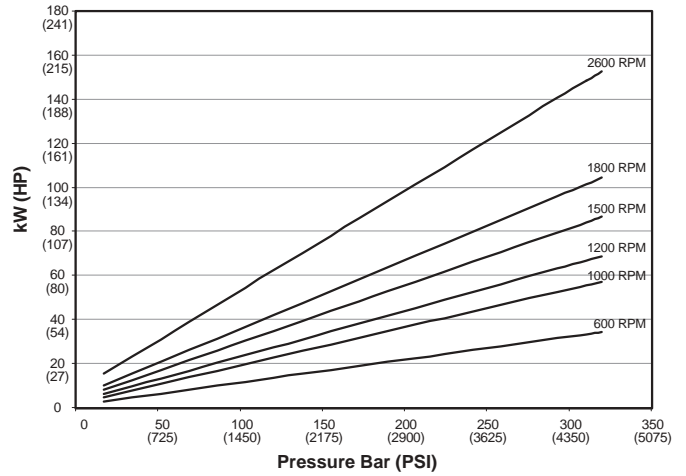

P3145 Input Power - Full Stroke

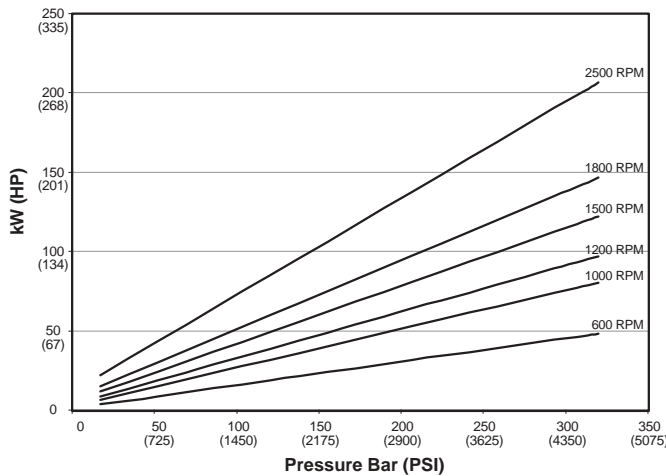

Performance Data

P3 Series Typical Compensated Power

Fluid: Mineral oil ISO VG 32 @ 40° C

Inlet pressure: 1.0 Bar (14.5 PSI) (Absolute) measured at inlet port.

P3075 Input Power - Zero Stroke

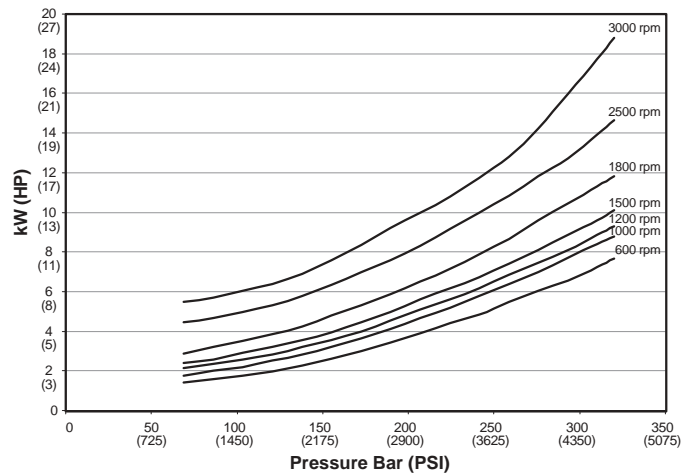

P3105 Input Power - Zero Stroke

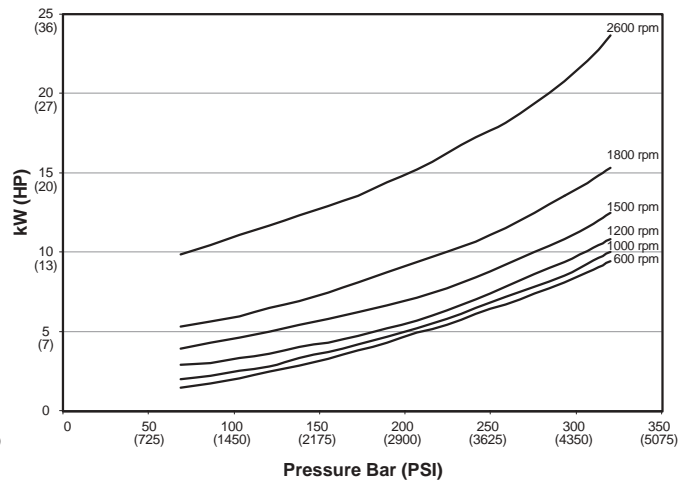

P3145 Input Power - Zero Stroke

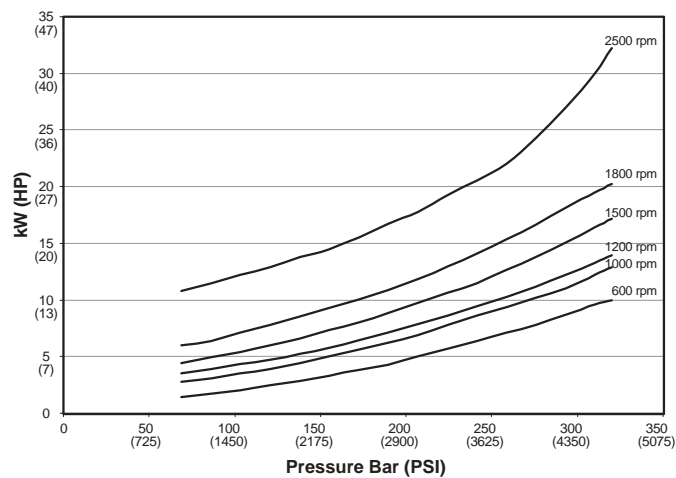

Performance Data

P3 Series Typical Efficiency at Full Displacement @ 1800 RPM

Fluid: Mineral oil ISO VG 32 @ 40° C

Inlet pressure: 1.0 Bar (14.5 PSI) (Absolute) measured at inlet port.

P3075 Efficiency at 1800 RPM

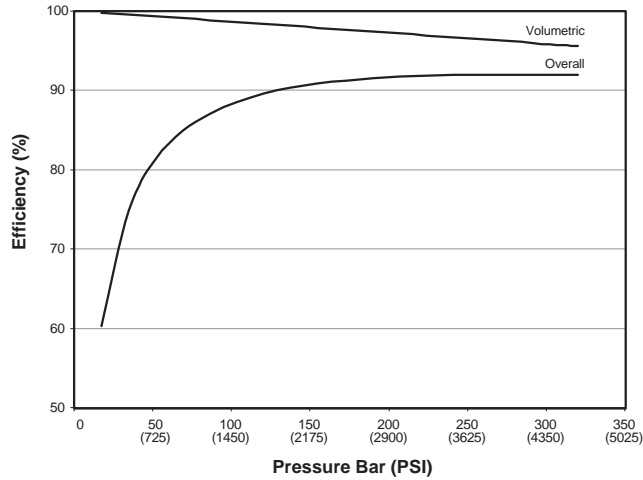

P3105 Efficiency at 1800 RPM

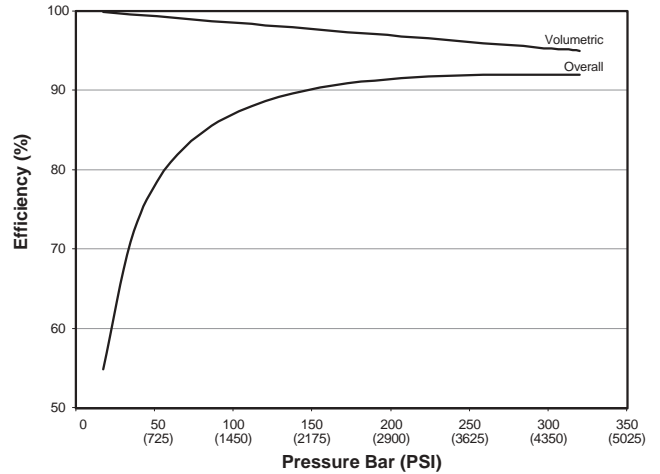

P3145 Efficiency at 1800 RPM

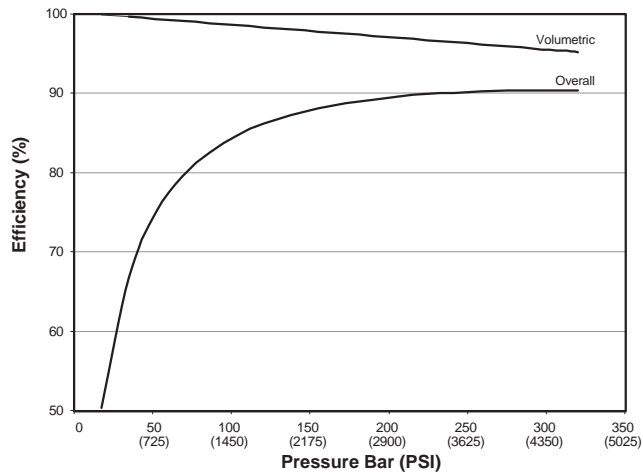

Performance Data

P3 Series Typical Flow vs. Pressure

Fluid: Mineral oil ISO VG 32 @ 40° C

Inlet pressure: 1.0 Bar (14.5 PSI) (Absolute) measured at inlet port.

P3075 Outlet Flow - Full Stroke

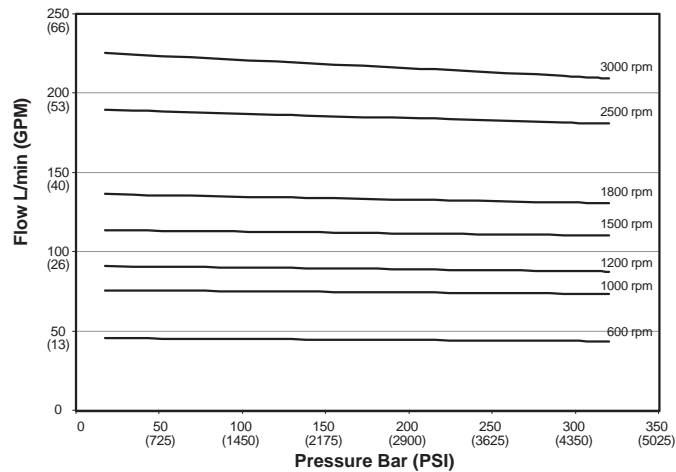

P3105 Outlet Flow - Full Stroke

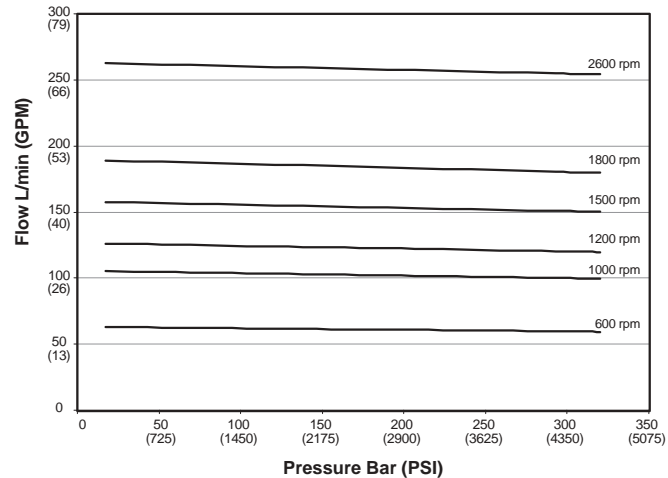

P3145 Outlet Flow - Full Stroke

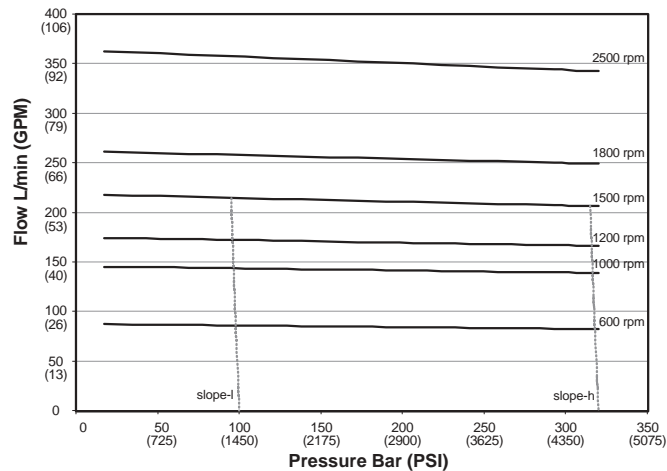

Performance Data

P3 Series Typical Compensated Control Drain Flow

Fluid: Mineral oil ISO VG 32 @ 40° C

Inlet pressure: 1.0 Bar (14.5 PSI) (Absolute) measured at inlet port.

P3075 Control Drain Flow at Zero Stroke

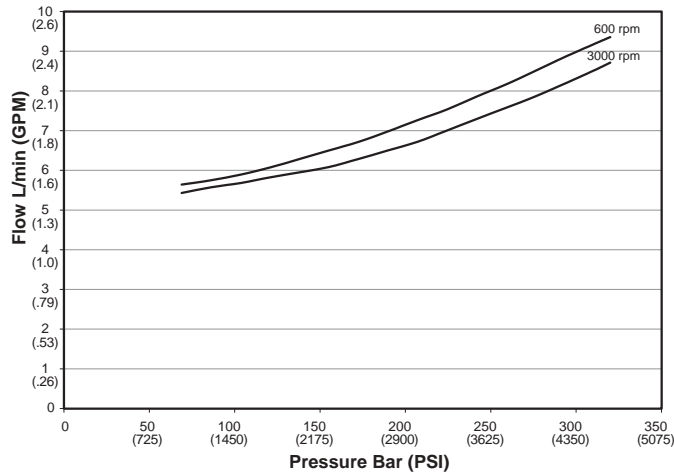

P3105 Control Drain Flow at Zero Stroke

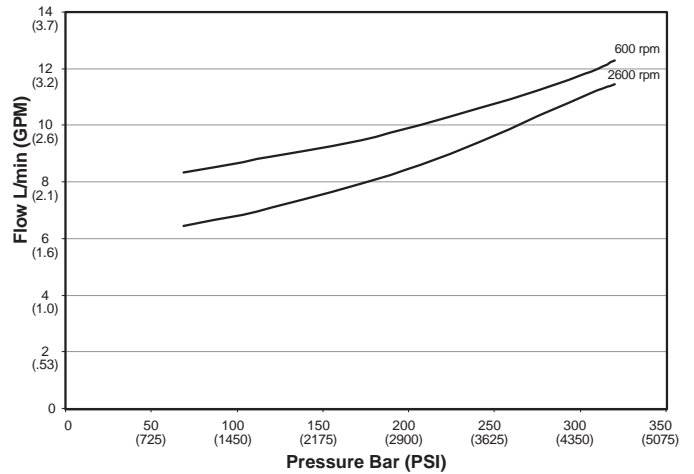

P3145 Control Drain Flow at Zero Stroke

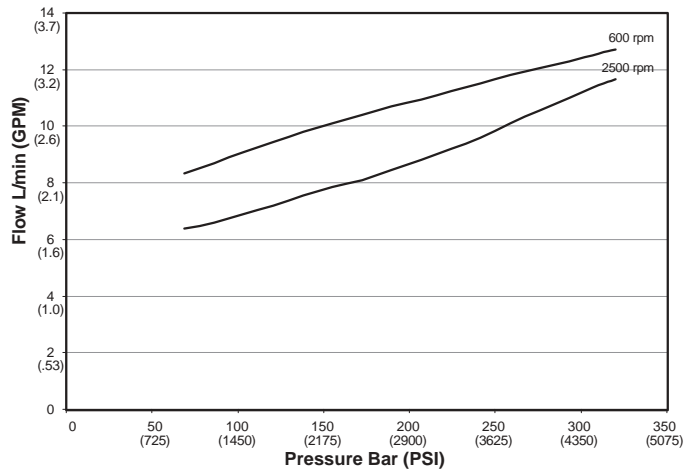

Dimensional Data

Pump Installation - P3-075 Mounting Flange

Port Options	Airbleed Port Vent Port
"A" Side - UNC	SAE-4 Straight Thread O-ring Port 7/8-20 UN Thread
"B" Side - Metric	ISO 6149 Straight Thread O-ring Port M12 x 1.5 Thread

SAE C 2-BOLT AND 4-BOLT MOUNTING FLANGE

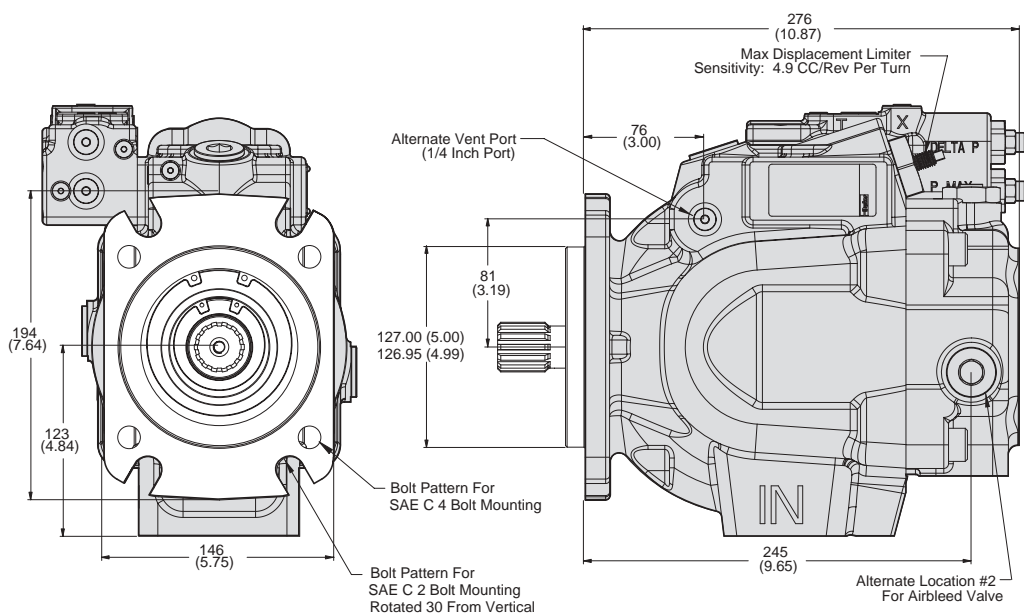

Dimensional Data

Pump Installation - P3-075 Side Port

Port Options	Inlet Port	Outlet Port	Inlet Gauge Port Outlet Gauge Port Airbleed Port Signal Port
"A" Side - UNC	1/2-13 UNC	7/16-14 UNC	SAE-4 Straight Thread O-ring Port 7/16-20 UN Thread
"B" Side - Metric	M12 x 1.75	M12 x 1.75	ISO 6149 Straight Thread O-ring Port M12 x 1.5 Thread

REAR VIEW

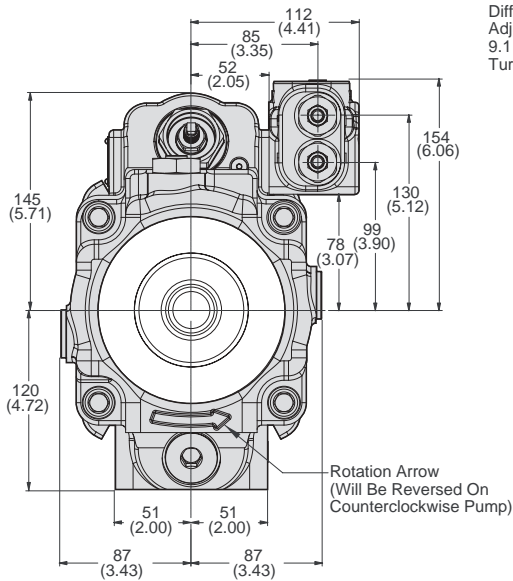

TOP VIEW

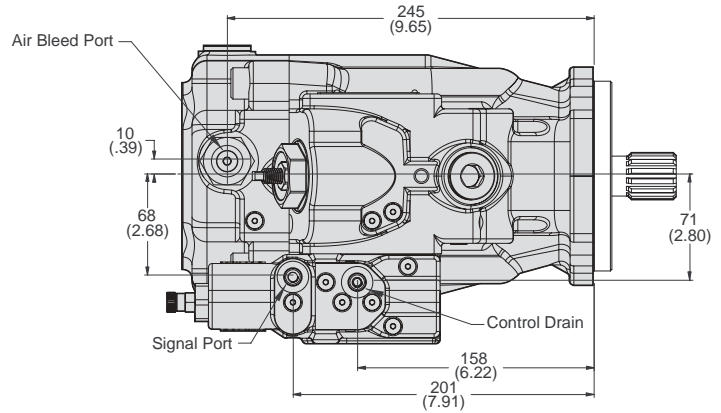

SIDE VIEW

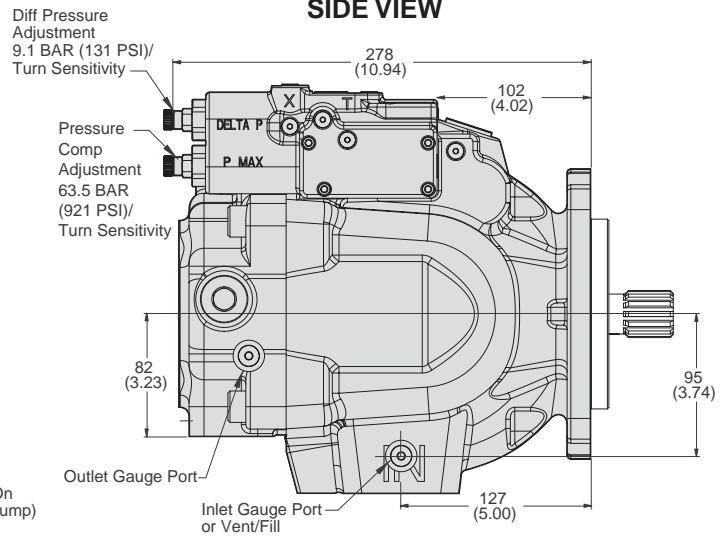

BOTTOM VIEW

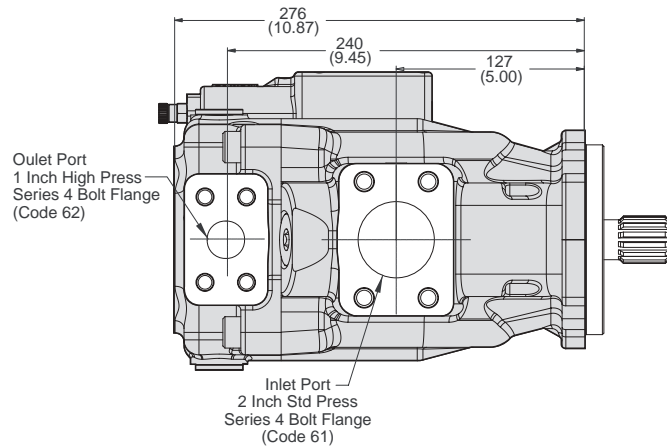

Dimensional Data

Pump Installation - P3-075 Thru-Shaft Option

Thru-Shaft Option	A	B	C	D	E	F "A" & "G"	F "B" & "G"
A1	292.5 (11.51)	∅ 82.626/ 82.575 (3.252/ 3.250)	106.3 (4.19)	N/A	SAE-A Spline 9 Tooth 16/32 Pitch	3/8-16 UNC-2B THD	M10 x 1.5 THD
B1	325.5 (12.81)	∅ 101.676/ 101.625 (4.002/ 4.001)	146.1 (5.75)	N/A	SAE-B Spline 13 Tooth 16/32 Pitch	1/2-13 UNC-2B THD	M12 x 1.75 THD
B2	325.5 (12.81)	∅ 101.676/ 101.625 (4.002/ 4.001)	146.1 (5.75)	N/A	SAE-BB Spline 15 Tooth 16/32 Pitch	1/2-13 UNC-2B THD	M12 x 1.75 THD
C1	327.5 (12.89)	∅ 127.075/ 127.025 (5.003/ 5.001)	181 (7.13)	114.5	SAE-C Spline 14 Tooth 12/24 Pitch	5/8-11 UNC-2B THD	M16 x 2 THD
C3	327.5 (12.89)	∅ 127.075/ 127.025 (5.003/ 5.001)	181 (7.13)	114.5	SAE-C Spline 14 Tooth 12/24 Pitch	1/2-13 UNC-2B THD	M12 x 1.75 THD

* All shaft Couplings 30 Degrees Involute Spline Flat Root Side Fit

A1 CONFIGURATION

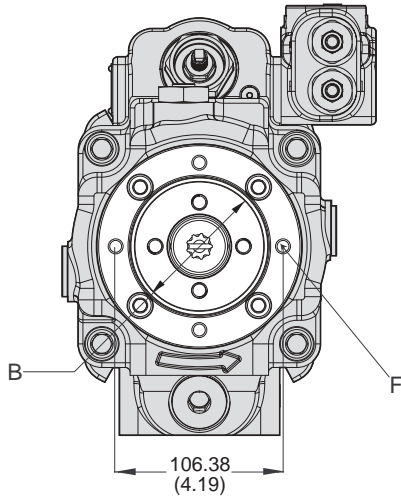

B1 & B2 CONFIGURATION

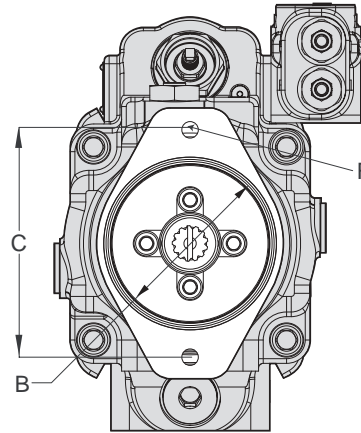

C1 & C3 CONFIGURATION

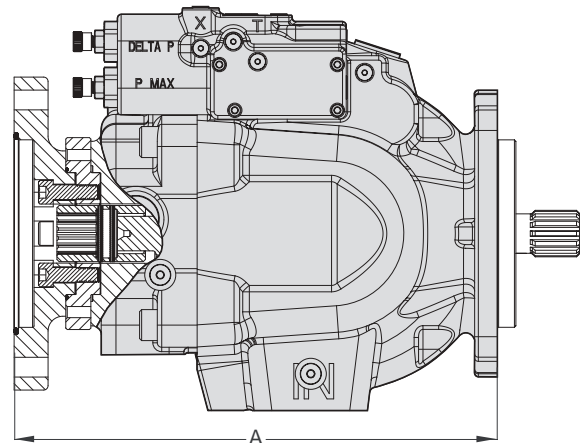
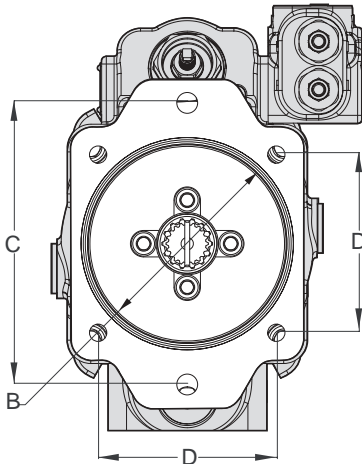

Max Thru-Drive Torque is 429 Nm (3800 lb in)

Dimensional Data

Pump Installation - P3-105 Mounting Flange

Port Options	Airbleed Port Vent Port
"A" Side - UNC	SAE-4 Straight Thread O-ring Port 7/16-20 UN Thread
"B" Side - Metric	ISO 6149 Straight Thread O-ring Port M12 x 1.5 Thread

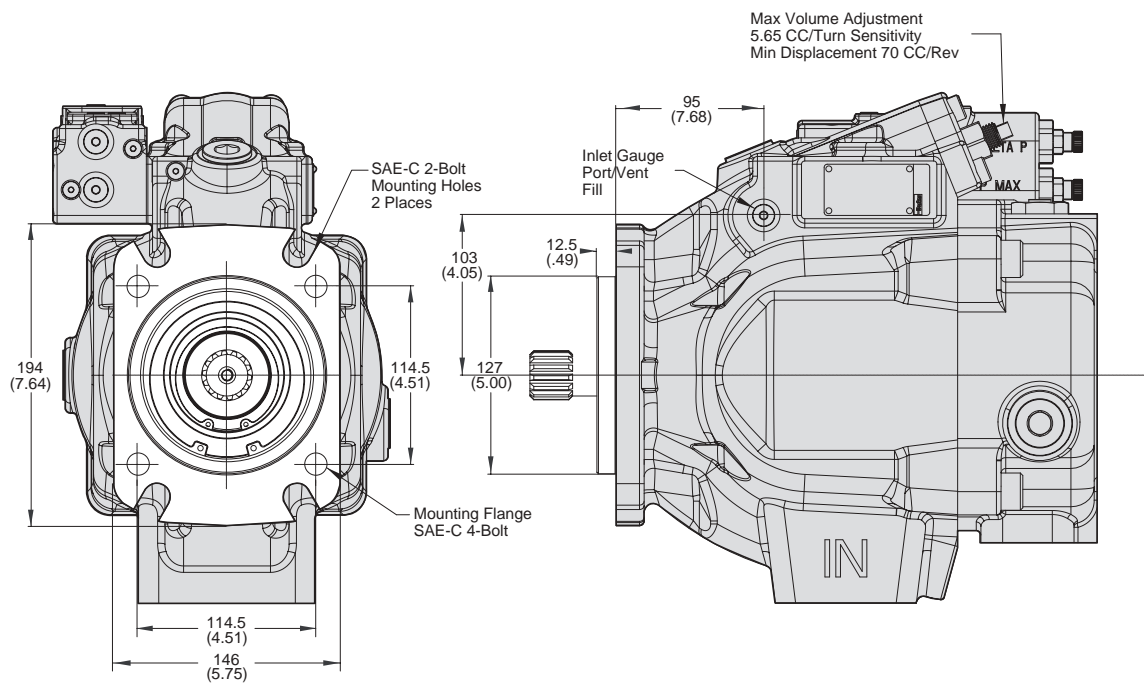

Dimensional Data

Pump Installation - P3-105 Side Port

Port Options	Inlet Port	Outlet Port	Inlet Gauge Port Outlet Gauge Port Airbleed Port Control Drain Signal Port
"A" Side - UNC	1/2-13 UNC	1/2-13 UNC	SAE-4 Straight Thread O-ring Port 7/16-20 UN Thread
"B" Side - Metric	M12 x 1.75	M12 x 1.75	ISO 6149 Straight Thread O-ring Port M12 x 1.5 Thread

TOP VIEW

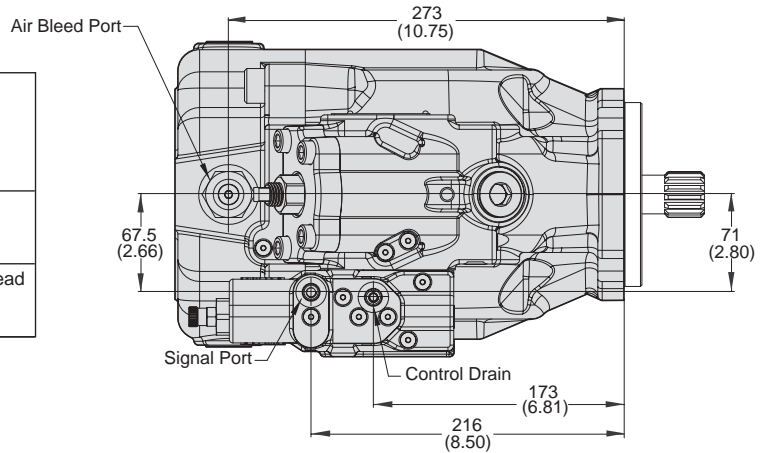

REAR VIEW

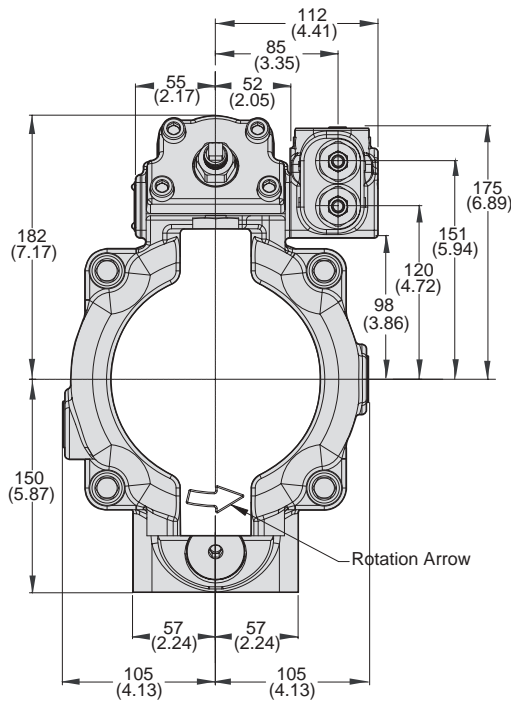

SIDE VIEW

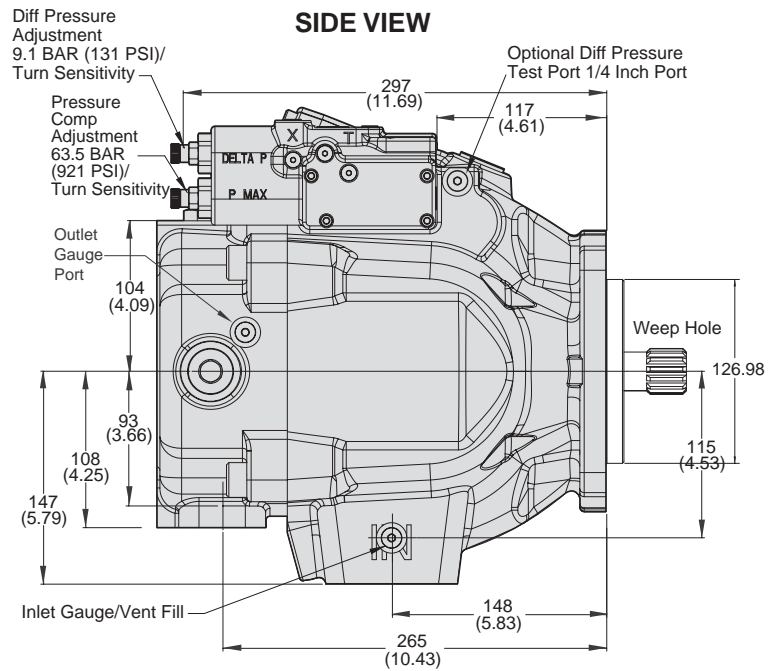

BOTTOM VIEW

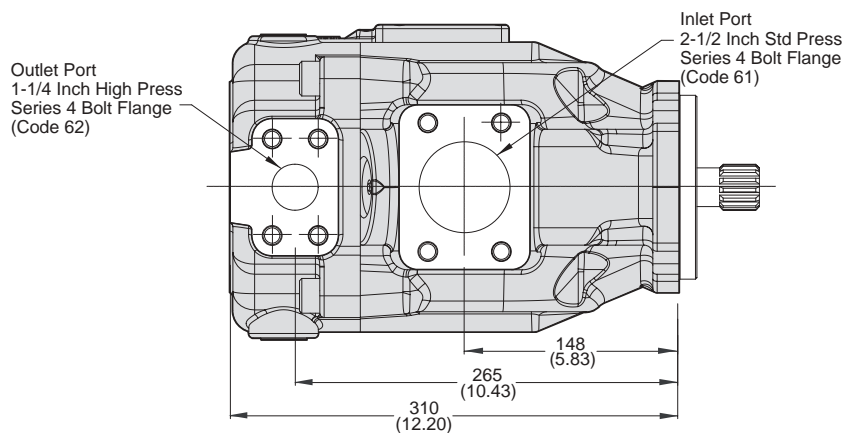

Dimensional Data

Pump Installation - P3-105 Thru-Shaft Option

Thru-Shaft Option	A	B	C	D	E	F UNC	F Metric	G UNC	G Metric
A1	292.5 (11.51)	∅ 82.626/ 82.575 (3.252/ 3.250)	106.3 (4.19)	N/A	SAE-A Spline 9 Tooth 16/32 Pitch	3/8-16 UNC-2B THD	M10 x 1.5 THD	N/A	N/A
B1	325.5 (12.81)	∅ 101.676/ 101.625 (4.002/ 4.001)	146.1 (5.75)	N/A	SAE-B Spline 13 Tooth 16/32 Pitch	1/2-13 UNC-2B THD	M12 x 1.75 THD	N/A	N/A
B2	325.5 (12.81)	∅ 101.676/ 101.625 (4.002/ 4.001)	146.1 (5.75)	N/A	SAE-BB Spline 15 Tooth 16/32 Pitch	1/2-13 UNC-2B THD	M12 x 1.75 THD	N/A	N/A
C1	327.5 (12.89)	∅ 127.075/ 127.025 (5.003/ 5.001)	181 (7.13)	114.5	SAE-C Spline 14 Tooth 12/24 Pitch	1/2-13 UNC-2B THD	M12 x 1.75 THD	5/8-11 UNC-2B THD	M16 x 2 THD
C3	327.5 (12.89)	∅ 127.075/ 127.025 (5.003/ 5.001)	181 (7.13)	114.5	SAE-C Spline 14 Tooth 12/24 Pitch	1/2-13 UNC-2B THD	M12 x 1.75 THD	5/8-11 UNC-2B THD	M16 x 2 THD

* All shaft Couplings 30 Degrees Involute Spline Flat Root Side Fit

*** Maximum Thru Drive Capability is Limited to 587Nm (5195 lb in)

A1 CONFIGURATION

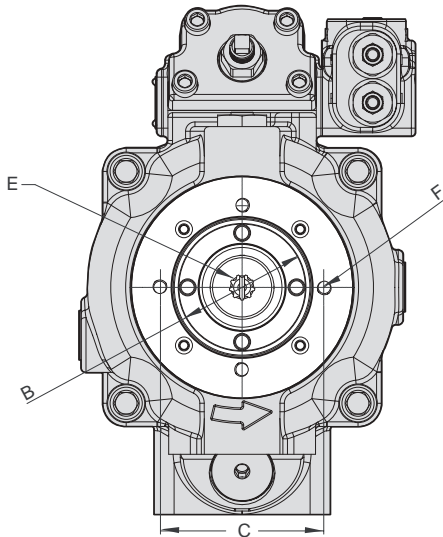

B1 & B2 CONFIGURATION

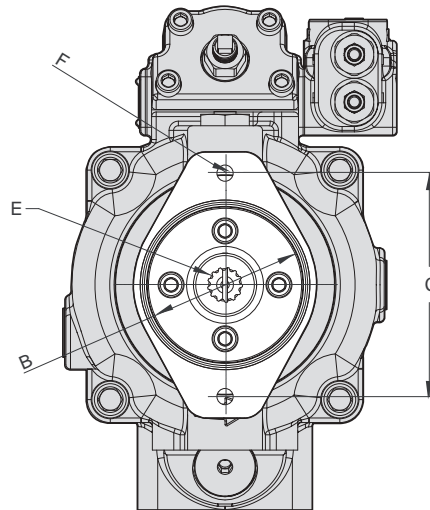

C1 & C3 CONFIGURATION

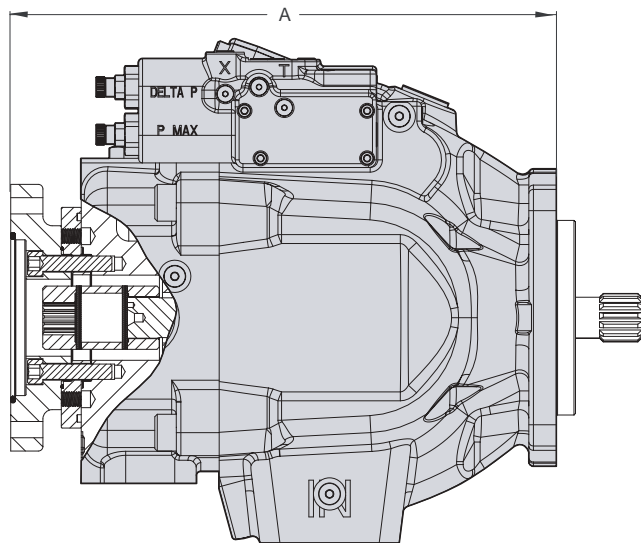
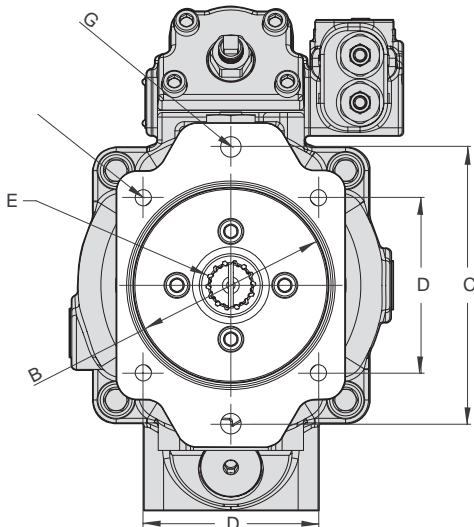

Dimensional Data

Pump Installation - P3-145 Mounting Flange

Port Options	Airbled Port Vent Port
"A" Side - UNC	SAE-4 Straight Thread O-ring Port 7/16-20 UN Thread
"B" Side - Metric	ISO 6149 Straight Thread O-ring Port M12 x 1.5 Thread

SAE C 2-BOLT MOUNTING FLANGE

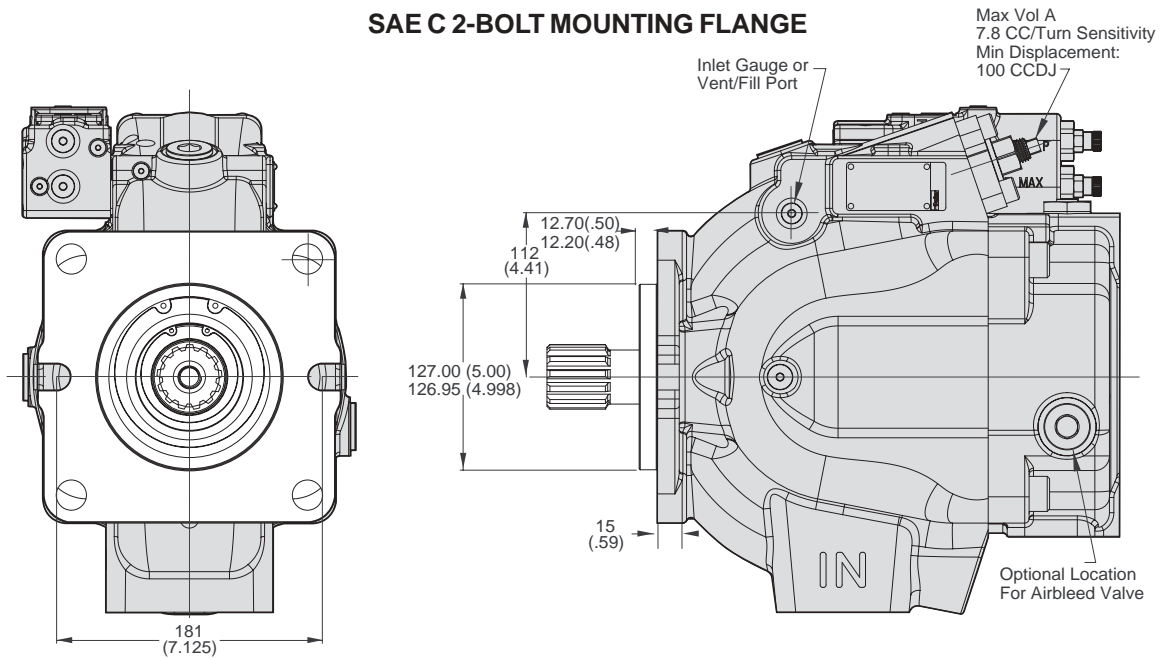

SAE D 4-BOLT MOUNTING FLANGE

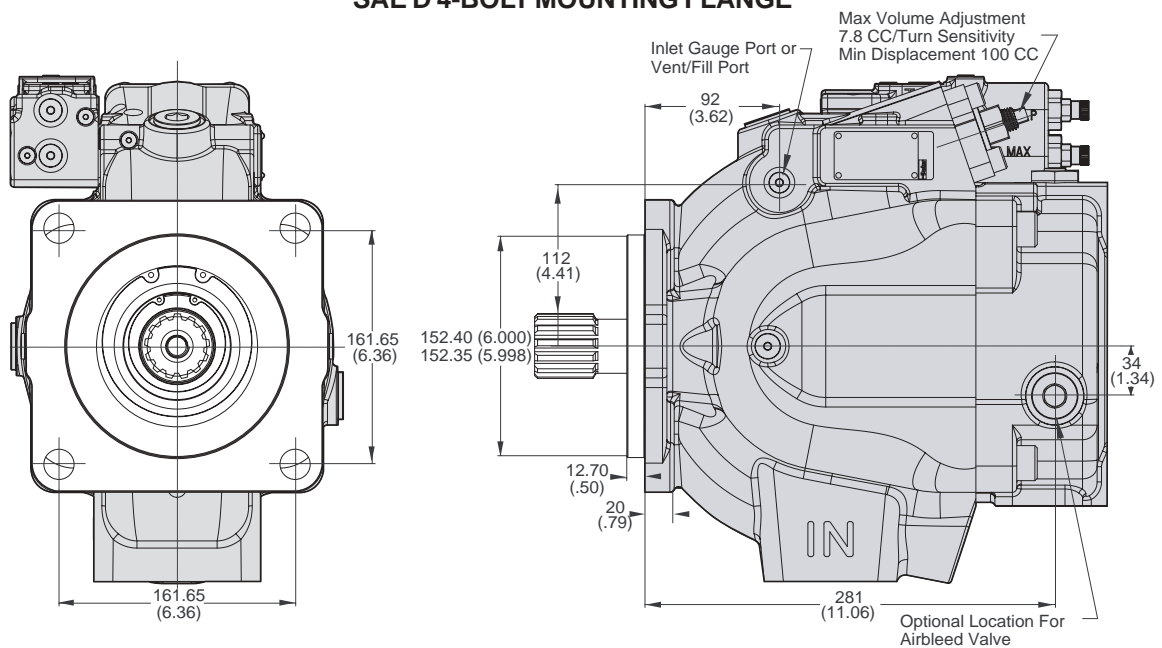

Dimensional Data

Pump Installation - P3-145 Side Port

Port Options	Inlet Port	Outlet Port	Inlet Gauge Port Outlet Gauge Port Airbleed Port Control Drain Signal Port
"A" Side - UNC	1/2-13 UNC	1/2-13 UNC	SAE-4 Straight Thread O-ring Port 7/16-20 UN Thread
"B" Side - Metric	M12 x 1.75	M12 x 1.75	ISO 6149 Straight Thread O-ring Port M12 x 1.5 Thread

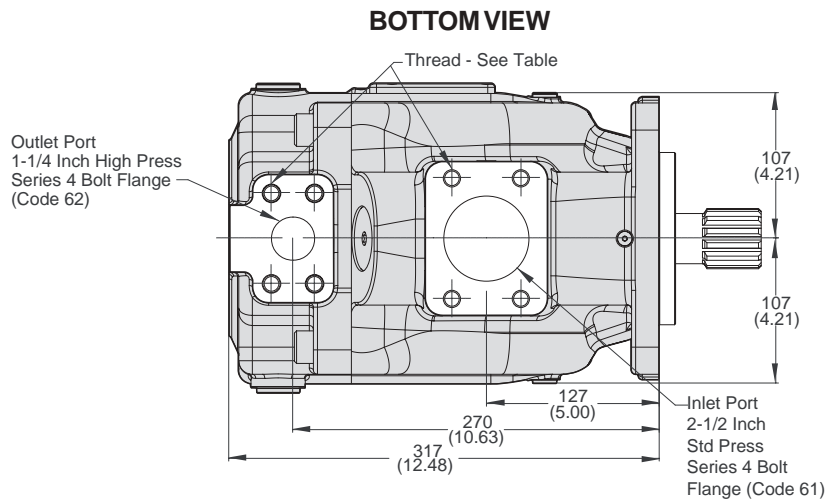
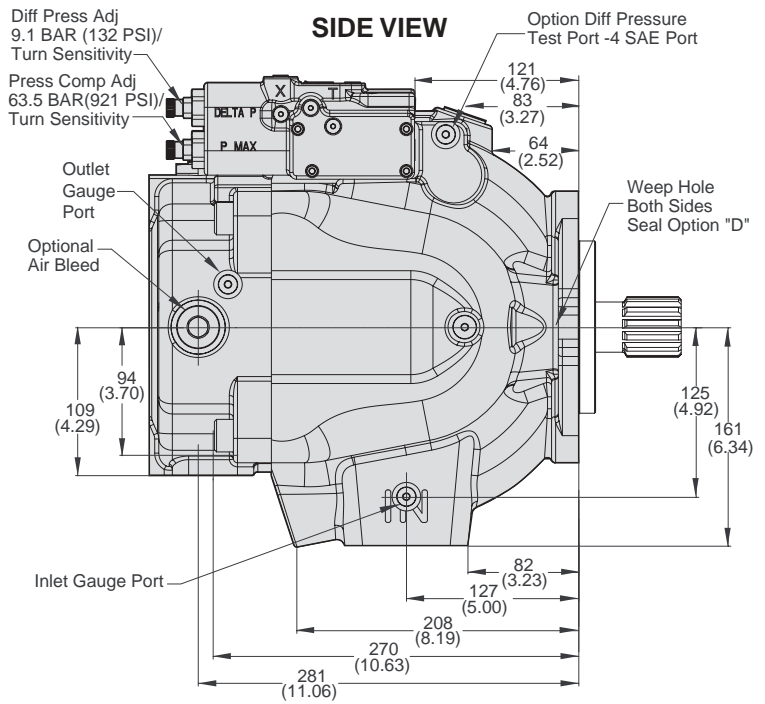
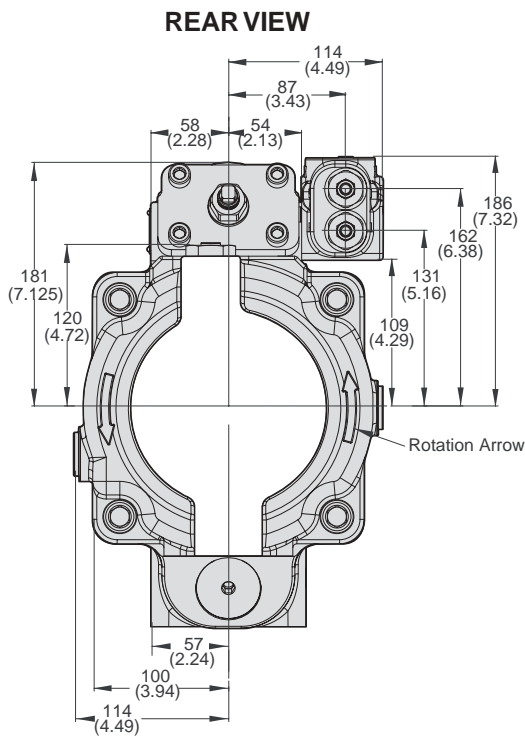
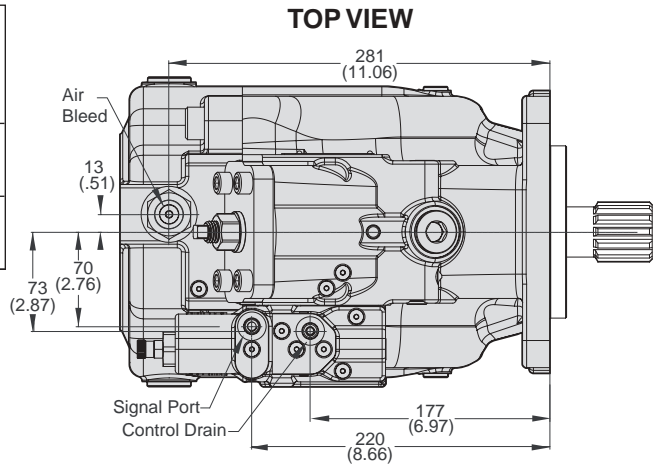

Dimensional Data

Pump Installation - P3-145 Thru-Shaft Option

Thru-Shaft Option	A	B	C	D	E	F UNC	F Metric	G UNC	G Metric	Pump Weight
A1	329.5 (13.0)	∅ 82.626/ 82.575 (3.252/ 3.250)	106.38 (4.19)	N/A	SAE-A Spline 9 Tooth 16/32 Pitch	3/8-16 UNC-2B THD	M10 x 1.5 THD	N/A	N/A	75.7 (167)
B1	362.5 (14.27)	∅ 101.676/ 101.625 (4.002/ 4.001)	146.05 (5.75)	N/A	SAE-B Spline 13 Tooth 16/32 Pitch	1/2-13 UNC-2B THD	M12 x 1.75 THD	N/A	N/A	78.5 (173)
B2	362.5 (14.27)	∅ 101.676/ 101.625 (4.002/ 4.001)	146.05 (5.75)	N/A	SAE-BB Spline 15 Tooth 16/32 Pitch	1/2-13 UNC-2B THD	M12 x 1.75 THD	N/A	N/A	78.5 (173)
C1	364.5 (14.35)	∅ 127.075/ 127.025 (5.003/ 5.001)	180.98 (7.13)	N/A	SAE-C Spline 14 Tooth 12/24 Pitch	5/8-11 UNC-2B THD	M16 x 2 THD	1/2-13 UNC-2B THD	M12 x 1.75 THD	80.0 (176)
C2	364.5 (14.35)	∅ 127.075/ 127.025 (5.003/ 5.001)	180.98 (7.13)	N/A	SAE-C Spline 17 Tooth 12/24 Pitch	5/8-11 UNC-2B THD	M16 x 2 THD	1/2-13 UNC-2B THD	M12 x 1.75 THD	80.0 (176)
C3	364.5 (14.35)	∅ 127.075/ 127.025 (5.003/ 5.001)	180.98 (7.13)	114.5	SAE-C Spline 14 Tooth 12/24 Pitch	5/8-11 UNC-2B THD	M16 x 2 THD	1/2-13 UNC-2B THD	M12 x 1.75 THD	80.0 (176)
C4	364.5 (14.35)	∅ 127.075/ 127.025 (5.003/ 5.001)	180.98 (7.13)	114.5	SAE-CC Spline 17 Tooth 12/24 Pitch	5/8-11 UNC-2B THD	M16 x 2 THD	1/2-13 UNC-2B THD	M12 x 1.75 THD	80.0 (176)
D3	375 (14.76)	∅ 152.475/ 152.425 (6.003/ 6.001)	N/A	161.65	SAE-D Spline 13 Tooth 8/16 Pitch	N/A	N/A	3/4-10 UNC-2B THD	M16 x 2 THD	83.9 (185)

*** Maximum Thru Drive Capability is Limited to 1217Nm (10777 lb in)

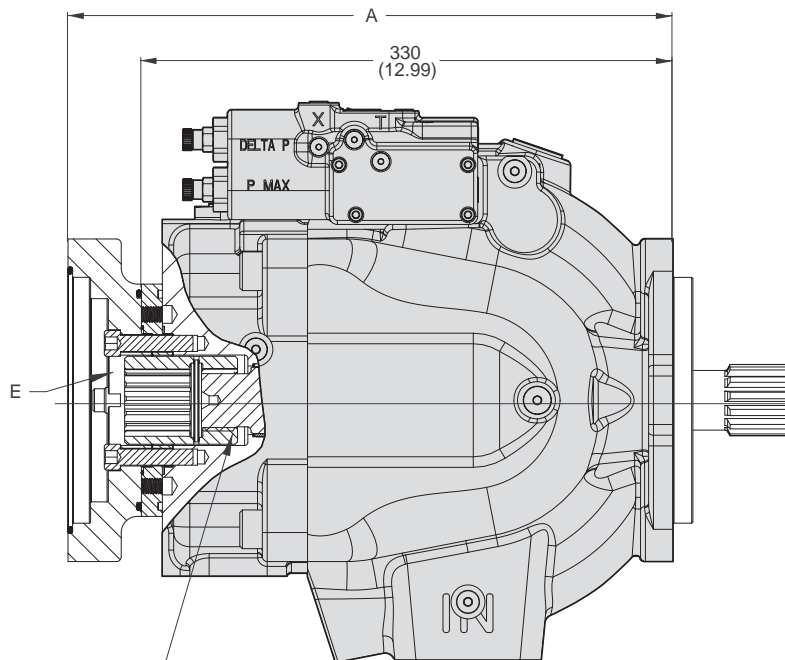

Dimensional Data

Pump Installation - P3-145 Thru-Shaft Option

A1 CONFIGURATION

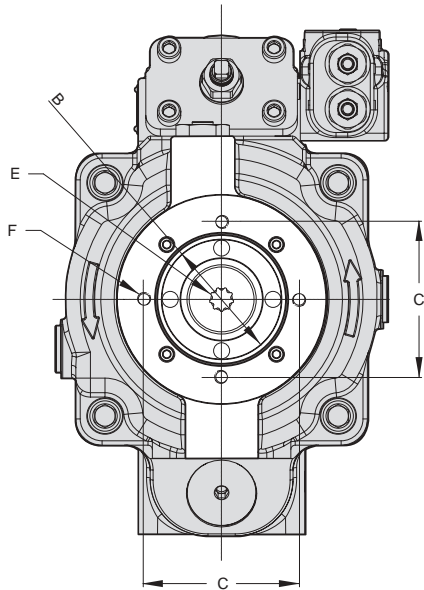

B1 & B2 CONFIGURATION

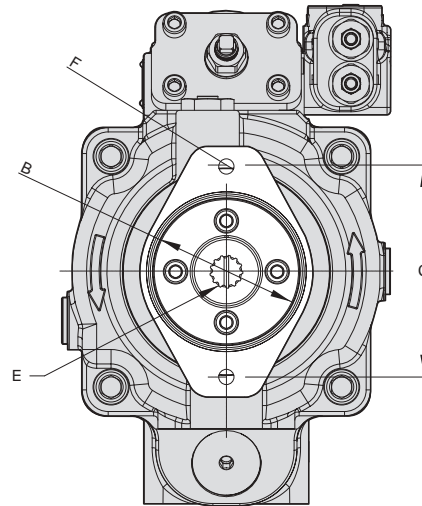

C1, C2, C3 & C4 CONFIGURATION

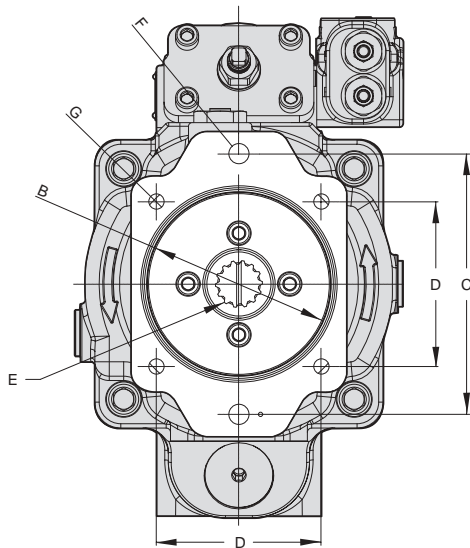

D3 CONFIGURATION

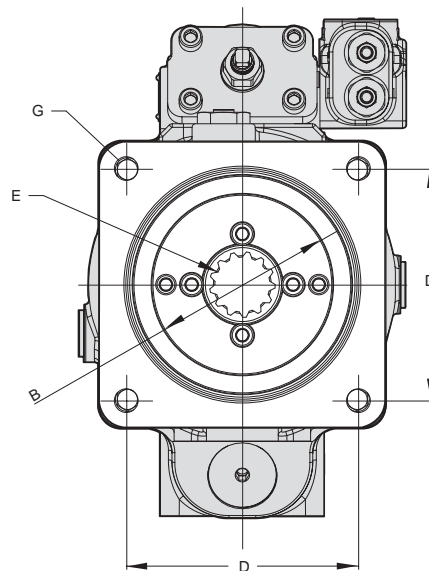

Dimensional Data

Pump Installation- P3 Shaft Options

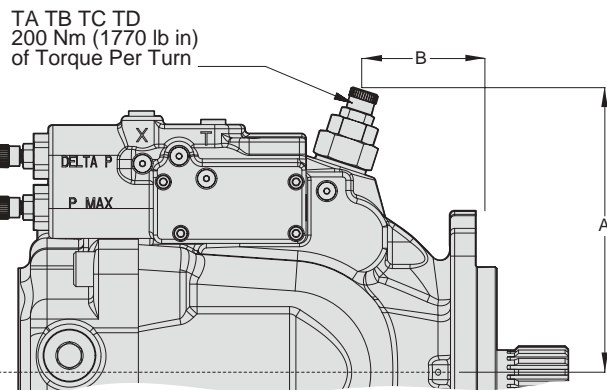
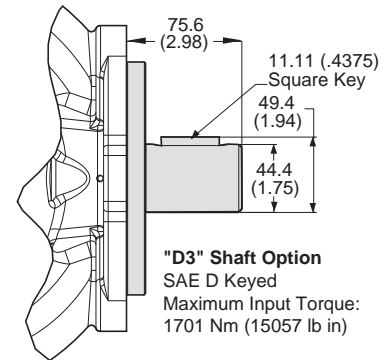
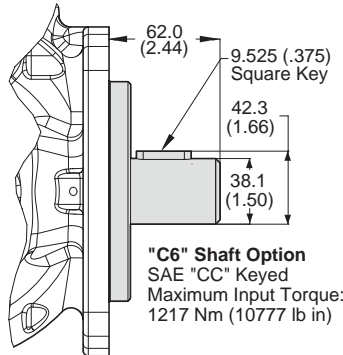
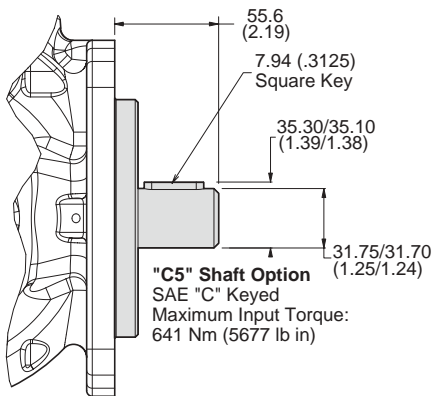
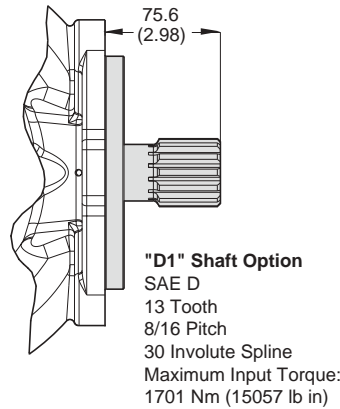
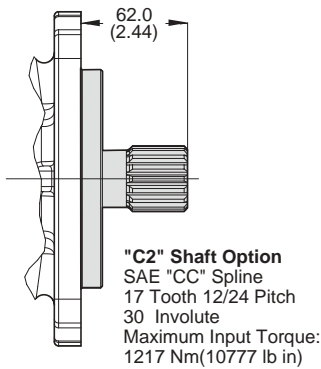
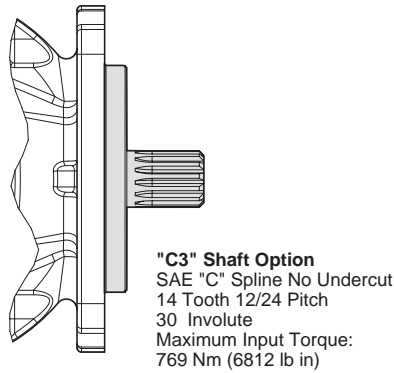
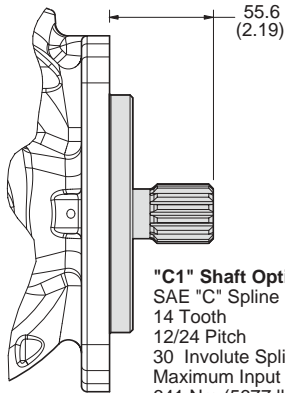

	P3075	P3105	P3145
A	171 (6.73)	190 (7.48)	202 (7.95)
B	69 (2.72)	69 (2.72)	69 (2.72)

Operating and Installation**Recommended Operating and Installation Instructions**

Filtration	For maximum pump and system component life, a fluid contamination level of 19/16/13 per ISO 4406:1999 is recommended. A maximum fluid contamination level of 21/18/14 per ISO 4406:1999 will result in a reduced pump and component life.
Temperature Range	Normal working fluid temperature in tank 0°C - 70°C (+32°F to +158°F) Maximum operating case drain temperature + 90°C (+194°F) Cold start temperature -40°C (-40°F)
Fluid	Premium hydraulic fluid with a normal operating viscosity range between 15 - 40 cSt. Maximum viscosity is 1000 cSt for short periods. Minimum viscosity is 10 cSt for short periods. Oil should have maximum anti-wear properties, rust, and oxidation inhibitors.

Installation Instructions

- When mounting the pump on a system where the fluid level is above the pump inlet (L-shaped or overhead reservoir) the pump case must be full of fluid before starting. This can be accomplished by loosening an inlet gauge port plug or opening the inlet line and allowing gravity to pre-fill the inlet line and case.

When mounting the pump on a system where the fluid level is below the pump inlet (JIC reservoir) the following start-up procedure is recommended. Put approximately 16 ounces of fluid in the pump case to lubricate parts during priming. Remove plug (7/16-20 SAE-4) from air bleed drain port and connect an unrestricted line to tank below minimum fluid level. Start motor and run until pump primes or a maximum of 30 seconds. If pump does not prime in 30 seconds, stop motor (shaft rotating) and repeat until pump primes.
- Do not apply side loads to the pump drive shaft. If side loading is necessary contact your Parker representative.
- Pump and motor shaft alignment must be within .25 millimeters (0.010 inches) TIR using standard floating coupling (no end loading).
- The P2/P3 series of pumps are uni-directional and must be driven in the direction indicated by the arrow on the back of the rear cover.
- Check all inlet connections to be sure they are airtight. An air leak in the inlet line can cause the pump case to drain down and lose prime during succeeding start-ups.
- The pressure compensator is factory set and can be lowered for start-up. Clockwise rotation increases the compensator setting and counter clockwise rotation decrease the compensator setting. Pump compensator should be set with the system deadheaded.
- The differential pressure adjustment and torque control adjustment are factory set - readjustment is not recommended, contact your Parker representative.

P2/P3 Installation Differences

The P3 series pumps are equipped with a control drain, as opposed to a case drain on the P2 series.

Please follow the following instructions for the P3 series.

- The "T" port in the compensator manifold is the control drain and must be connected directly to tank below minimum fluid level. This line should not be combined with other drain or tank lines as back pressure surges could occur causing compensator instability. Back pressure on the control drain will result in an increase in maximum pressure setting.
- An airbleed is standard on P3 series pumps. When required remove airbleed plug (7/16-20 SAE-4) and connect directly to tank below minimum oil level. The airbleed comes in a standard position from the factory but may be relocated for installation requirements. If this is necessary, remove the appropriate plug (1 1/16-12 SAE-12) and install airbleed. The plug must be reinstalled in the port vacated by the airbleed. Both the airbleed and the plug must be torqued to 92 ft-lbs. Not torquing properly can cause o-ring failure.

Please follow the following instructions for the P2 series.

- The case drain line must be connected directly to the tank below fluid level as far away from the inlet line as possible. The case drain line should not be combined with any other drain, return, or suction line as back pressure surges could occur and adversely affect pump performance.