



Directional Control Valve M400LS

***Proportional, Load-Sensing
Directional Valve***

*Catalogue HY17-8535/UK
December 2004*





WARNING

FAILURE OR IMPROPER SELECTION OR IMPROPER USE OF THE PRODUCTS AND/OR SYSTEMS DESCRIBED HEREIN OR RELATED ITEMS CAN CAUSE DEATH, PERSONAL INJURY AND PROPERTY DAMAGE.

This document and other information from Parker Hannifin Corporation, its subsidiaries and authorized distributors provide product and/or system options for further investigation by users having technical expertise. It is important that you analyze all aspects of your application, including consequences of any failure, and review the information concerning the product or system in the current product catalogue. Due to the variety of operating conditions and applications for these products or systems, the user, through its own analysis and testing, is solely responsible for making the final selection of the products and systems and assuring that all performance, safety and warning requirements of the application are met.

The products described herein, including without limitation, product features, specifications, designs, availability and pricing, are subject to change by Parker Hannifin Corporation and its subsidiaries at any time without notice.

Offer of Sale

Please contact your Parker representation for a detailed "Offer of Sale".

Contents	Page
Catalogue layout	4
General Information	5
Technical Data	6
Pressure	6
Flow rate (recommended)	6
Leakage from service port to tank	6
Environmental characteristics	6
Temperature	6
Weight	6
Connections	6
Filtration	7
Hydraulic fluids	7
Pressure drop	7
Hydraulic circuit diagram	8
Hydraulic circuit diagram detailing basic functions	8
Counterpressure function	9
Choice of spool	10
Spool function	10
Spool designations	10
Area relationships	10
Load characteristics	10
Load signal system	10
Spool actuators PC, FPC	11
Float position function (FPC)	11
Prioritizing function	11
Pressure limiters in service ports (Port relief valves)	12
Port relief valves	13
Pressure settings	13
Dimensional Drawings	14-15

Catalogue layout

This catalogue has been designed to give an overview of the M400LS valve and to make it easy for you to study and choose from the different valve functions available and customize your valve. General information and technical data is given first. This is followed by descriptions of the various options that can be specified and the dimensional drawings.

Each function is given as a subheading, e.g. **Spool function**, followed by a brief description. This is followed by a series of letter codes, e.g. **D, EA, M, F**, together with a brief description of what each code represents.

How to order your valve

The next step is to complete our so-called "Customer Specification Form" (CSF), which makes it easy to specify in detail the optional functions you wish to incorporate into your valve. It is simply a matter of entering the codes for the desired options into the blank boxes in the CSF, which has the same headings and letter codes as those given in this catalogue.

Should you require assistance in completing the CSF, please do not hesitate to contact your nearest Parker representative,

who will either help personally or refer you to the appropriate product specialist. The information in your CSF will be entered into our computerized valve specification program, which generates a unique ID number that will be stamped into the data plate on your valve. This valve specification will then be stored on our database to facilitate accurate identification of the product in the event of re-ordering or service-related matters.

Early consultation with Parker saves time and money

Our experienced applications engineers have in-depth knowledge of different hydraulic systems and the ways in which they work. They are at your disposal to offer expert advice on the desired combination of functions, control characteristics and economic demands.

By consulting Parker early in the project planning stage, you are assured of a comprehensive hydraulic system that gives your machine the best possible operating and control performance.

Conversion factors

1 kg	= 2.2046 lb
1 N	= 0.22481 lbf
1 bar	= 14.504 psi
1 l	= 0.21997 UK gallon
1 l	= 0.26417 US gallon
1 cm ³	= 0.061024 in ³
1 m	= 3.2808 feet
1 mm	= 0.03937 in
9/5 °C + 32	= °F

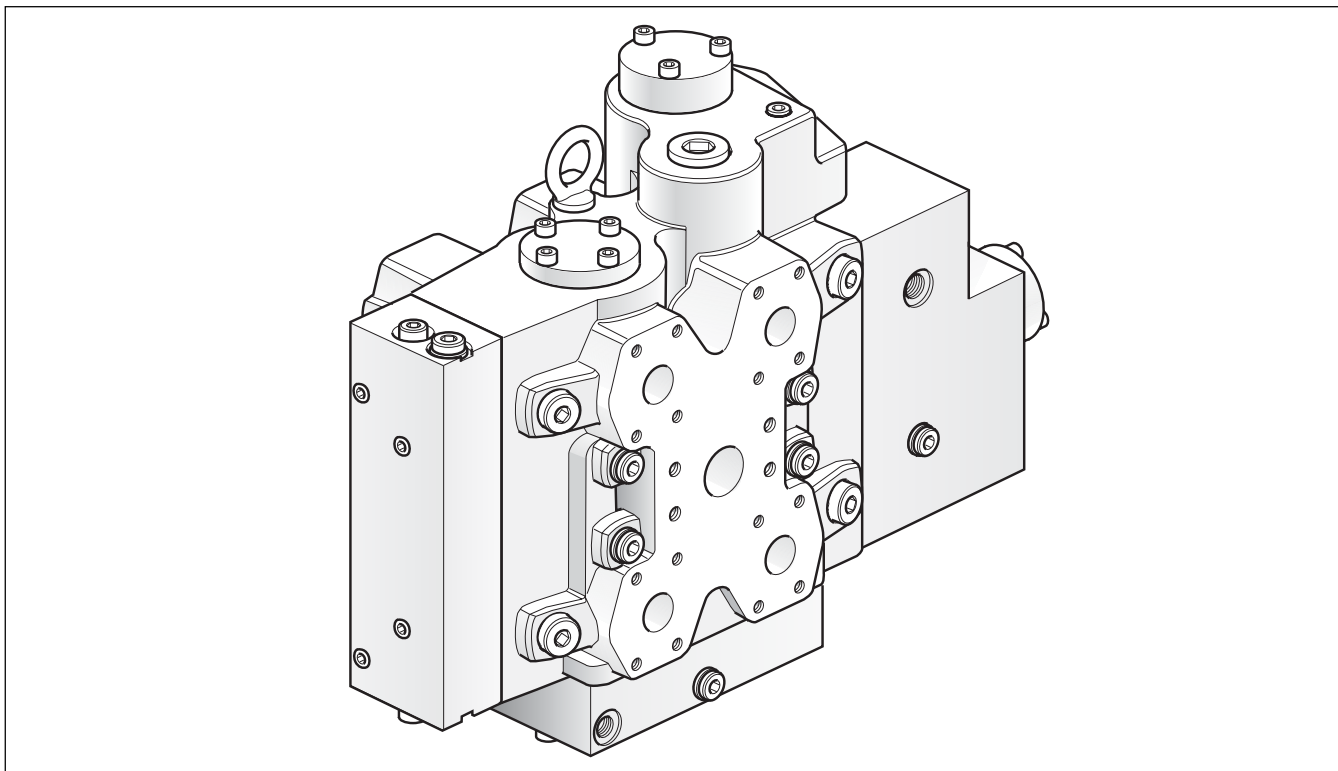

The M400LS is a directional valve intended for machines such as large wheeled-loaders, scoop trams, fork-lift trucks, etc. It is designed for use in closed-centre (LS) hydraulic systems with variable pumps, and is suitable for tough operating conditions where there are high demands on both external and internal sealing.

Simple installation

Good machine design and the right hydraulic system gives a cost-effective installation, which in turn gives a competitive product. The pump and service ports in the M400LS are arranged in such a way that hosing and piping can be kept to an absolute minimum. The valve is equipped with double service ports at 180°, which eliminates T-connectors and gives the shortest and simplest path to the cylinders. This also enables dimensions to be kept small, since only half the flow passes through each service port.

Double pump connections, located optimally for easy installation, enable the simple connection of a second pump.

When the valve is mounted upright on the bottom plate, as shown above good access for installation and service is obtained.

Safety

The M400LS is of robust and simple construction with a minimum of components, most of which are of the cartridge or module types, which facilitate both training and servicing. The valve is designed to meet high demands. It has both spool and poppet elements that give double safety in the case of hanging loads. The valve is also extremely well sealed, which prevents unintentional load sinking.

Design

The M400LS is constructed in one block - a so-called monoblock - and is of LS design for variable pumps. It is cast in high quality material to enable it to withstand high pressures without deformation. The valve is of the spool type to give safe and precise regulation of the flow. To ensure tight sealing in the case of hanging loads, there is also a poppet element which, together with the spool, effectively blocks the hanging load. The poppet elements are controlled via a logic system and opened by pilot pressure. The poppet element also functions as a load-hold check valve and as a prioritizing poppet on a port. All the logic elements and their associated spool actuators are assembled in two blocks.

The gallery system in the valve housing is generously dimensioned to give minimal pressure drop. This enables the feedback of tank flow to consumers, allowing high lowering speeds for light loads.

Essential characteristics

- Excellent sealing: service ports closed by means of poppet valves.
- Not sensitive to temperature shocks: poppet-valve concept gives relatively large clearance between spool and bore (which is impossible with ordinary spool valves).
- Good energy efficiency: low pressure drops for high function speeds; low energy consumption.
- Easy to install: designed with simple installation in mind.
- Optional float-position function: built-in, pressure-controlled float-position function eliminates the need for external components and signals.
- Great precision: low hysteresis gives precise control and good operator comfort.
- Easy to service: thanks to simple design and modular construction.
- Long service life: efficient port-relief and anti-cavitation valves reduce the number of pressure peaks and cavitations in the system, thus prolonging the life of the machine.

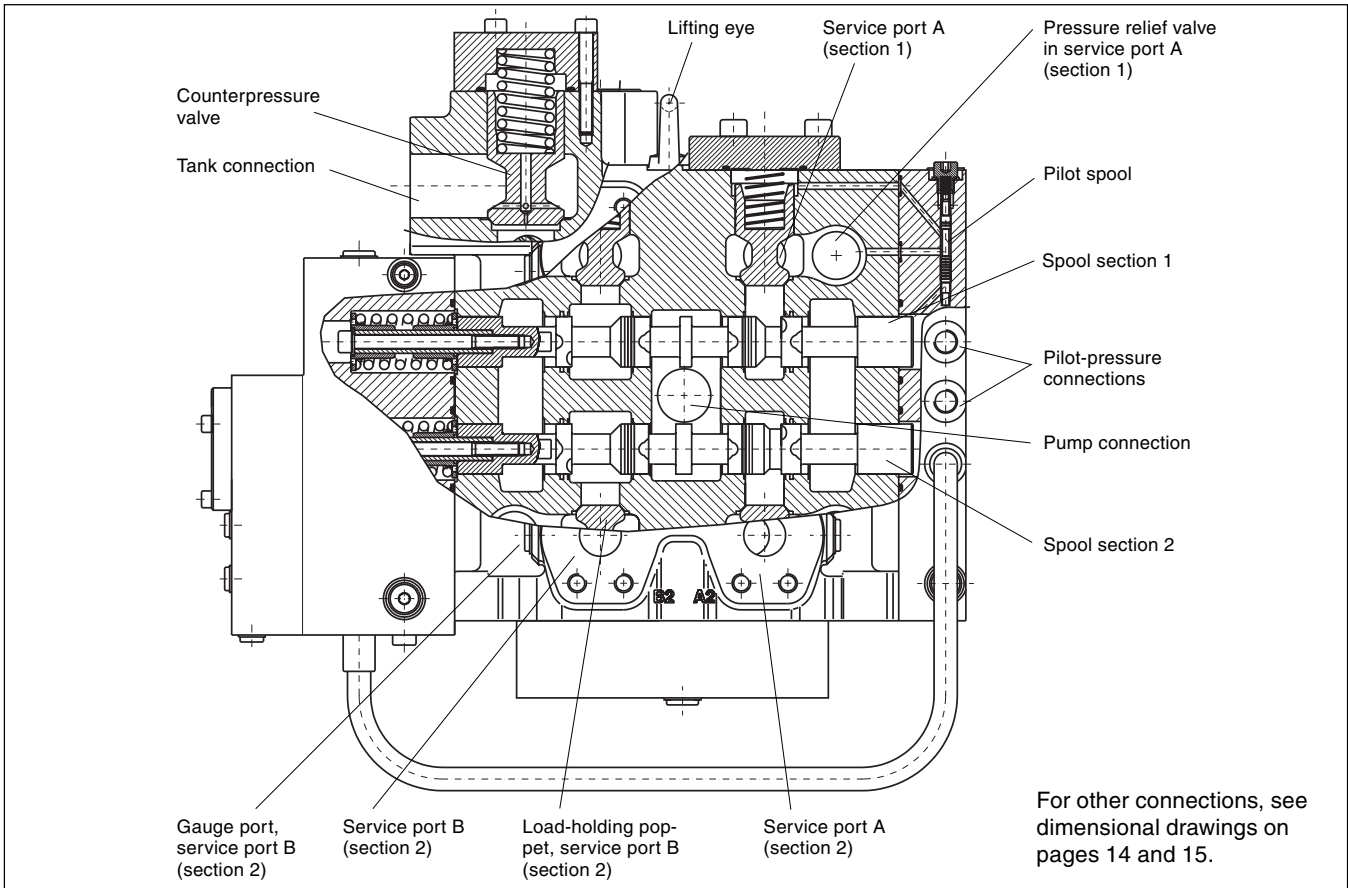

Pressure

Pump connection	max. working pressure	275 bar (3990 psi)
	max. peak pressure	300 bar (4350 psi)
Service port	max.	400 bar (5800 psi)
Tank connection, static	max.	50 bar (725 psi)

Flow rate (recommended)

Pump connection	900 l/min (238 US gpm)
Return from service port	1000 l/min (264 US gpm)
Max. flow rate to service port	450 l/min* (120 US gpm) at $\Delta p = 15$ bar (218 psi)

* Depending on choice of spool

Leakage from service port to tank

From A- or B-port: max. 20 cm³/min (1.22 in³/min) at 100 bar (1450 psi), oil temperature 50 °C (122 °F) and viscosity 30 mm²/s (cSt).

Environmental characteristics

While the valve can be mounted in any direction, it is best mounted upright (i.e. with lifting eye upwards) to give good access for servicing and enable simple handling. The base must be flat and stable to avoid stressing the valve on mounting.

The valve O-rings are of nitrile rubber as standard. In case of demands for high temperature resistance, please contact Parker for further information.

Weight

Valve complete with spool actuator for hydraulic servo and with float position option: 95 kg (210 lb)

Connections

Pump, tank and service-port connections are of the SAE flange type.

Pump connections	2 x 1 1/4"	SAE J518 "High pressure" (code 62). Fixing screw M14, depth of thread 27.
Service port connections	8 x 1"	SAE J518 "High pressure" (code 62). Fixing screw M12, depth of thread 27.
Tank connection	1 x 1 1/2"	SAE J518 "Std. pressure" (code 62). Fixing screw M14, depth of thread 27.
Pilot pressure connections		M14 x 1.5 for flat seal
Signal port		M14 x 1.5 for flat seal
Gauge port		M14 x 1.5 for flat seal

Filtration

Filtration must be arranged so that Target Contamination Class 20/18/14 according to ISO 4406 is not exceeded. For the pilot circuit, Target Contamination Class 18/16/13 according to ISO 4406 must not be exceeded.

Temperature

Oil temperature, working range +20 to +90 °C** (68 to 194 °F)*

Hydraulic fluids

Best performance is obtained using mineral-base oil of high quality and cleanness in the hydraulic system.

Hydraulic fluids of type HLP (DIN 51524), oil for automatic gearboxes Type A and engine oil type API CD can be used.

Viscosity, working range 15-380 mm²/s**

Technical information in this catalogue is applicable at an oil viscosity of 30 mm²/s and temperature of 50 °C (122 °F) using nitrile rubber seals.

* Product operating limits are broadly within the above range, but satisfactory operation within the specification may not be accomplished. Leakage and response will be affected when used at temperature extremes and it is up to the user to determine acceptability at these levels.

** Performance efficiency will be reduced if outside the ideal values. These extreme conditions must be evaluated by the user to establish suitability of the products performance.

Pressure drop

Pressure drop measured with fully open spool intended for max. flow.

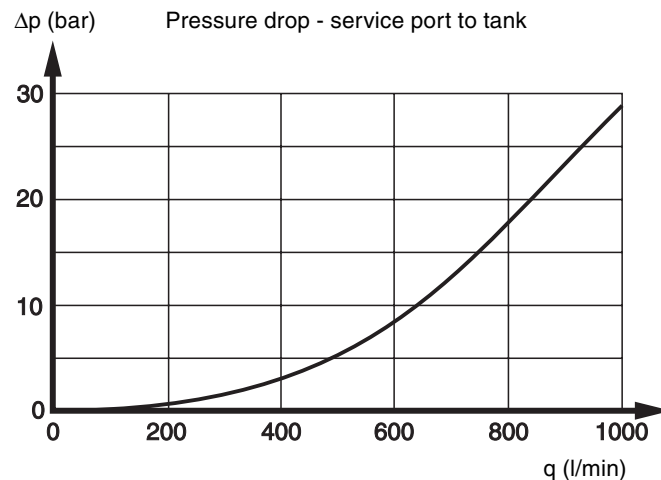

Pressure drop from service port A/B to tank connection T.

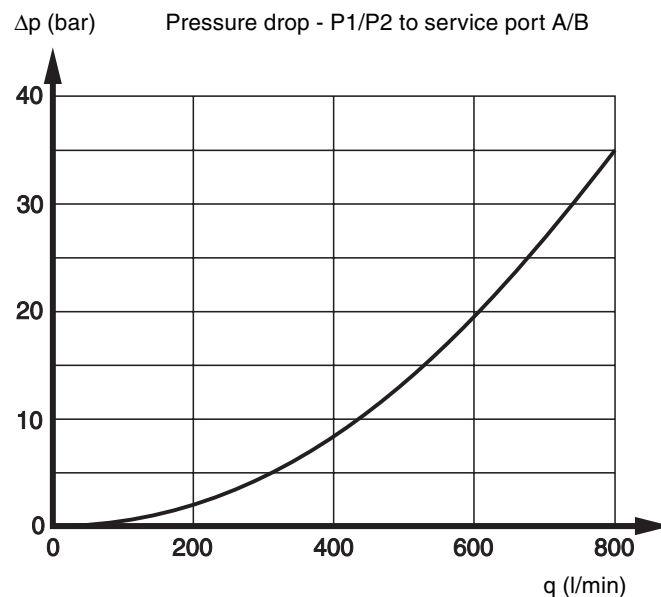

Pressure drop from pump connection P1/P2 to service port A/B.

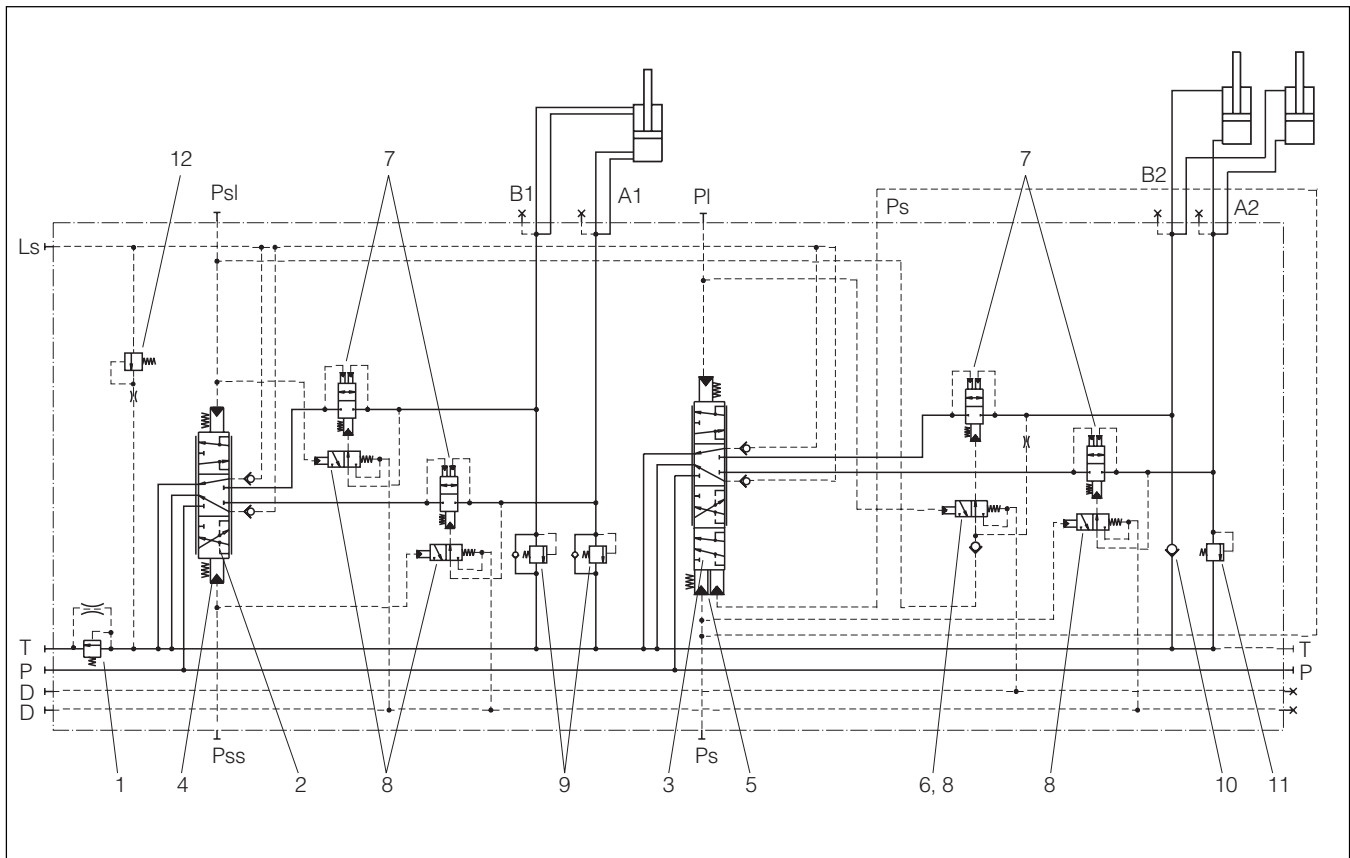

Hydraulic circuit diagram detailing basic functions

The valve in the diagram above and in the illustration on page 6 is equipped according to the list below. For several of the item numbers, alternative versions are available (see following pages in catalogue).

- 1 Counterpressure valve.
- 2 Spool in section 1 is of type D.
- 3 Spool in section 2 is of type F.
- 4 Spool in section 1 controlled by spool actuator type PC.
- 5 Spool in section 2 controlled by spool actuator type FPC.
- 6 Prioritizing function.
- 7 All service ports equipped with load-holding poppet.
- 8 Pilot spool for control of load-holding poppet.
- 9 Service ports in section 1 protected against overload and cavitation by combined port-relief and anti-cavitation valve type PA.
- 10 Service port B in section 2 protected against cavitation by anti-cavitation valve type N.
- 11 Service port A in section 2 protected against overload by port relief valve type PAY.
- 12 Load signal system drained via load-signal drainage poppet type LD.

Counterpressure function

The valve can be equipped with a counterpressure valve in the tank connection to ensure that oil from the cylinders is used primarily to replenish the system. The counterpressure valve has a low pressure setting (approx. 4 bar). This is possible thanks to the generous gallery dimensions and anti-cavitation valves. The valve is factory set. Other settings are available (optional).

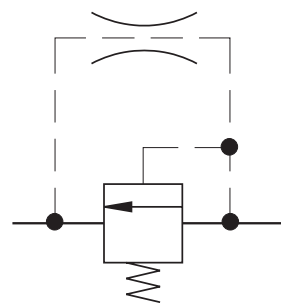
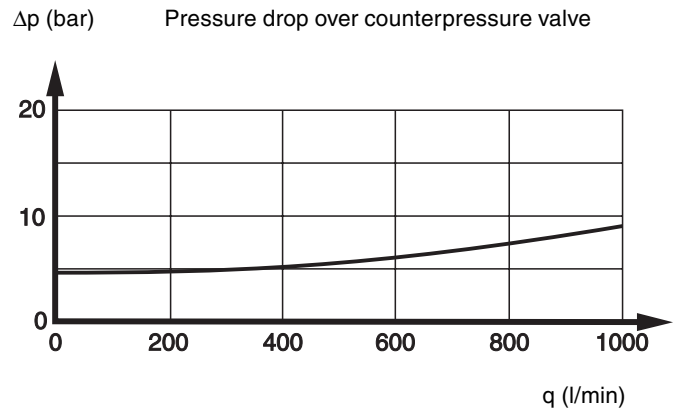

Counterpressure symbol. See also item 1 in complete circuit diagram, page 8.

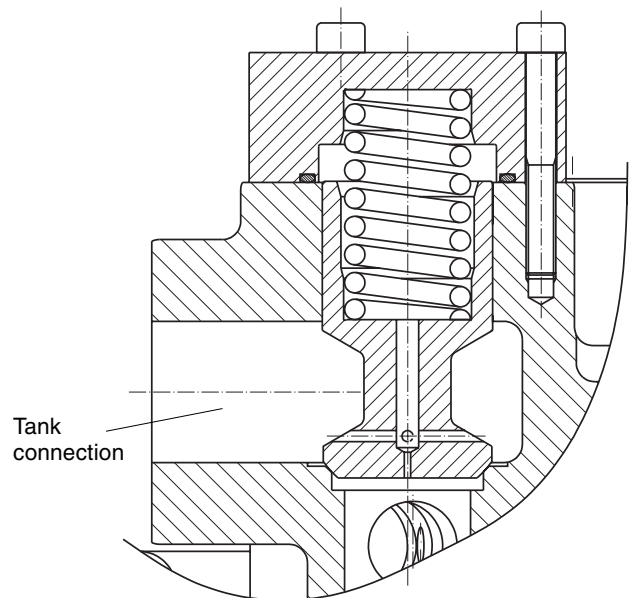

Counterpressure valve.

Choice of spool

The spool is the most important link between the actions of the machine operator and the movement of the controlled function. Parker therefore goes to great lengths to optimize spools for different flows, load conditions and functions. This continuous development work results in the continual introduction of new spools. For this reason, it is not practical to list in this catalogue the different spools available at any one time. For assistance in the choice of spool, we therefore ask you to contact Parker directly.

Spool function

Parker spools are divided into different groups depending on their basic functions.

- D** Double-acting spool for, e.g. double-acting cylinder. Blocked in the neutral position.
- EA** Single-acting spool for, e.g. single-acting cylinder. Blocked in the neutral position. Service port B blocked.
- M** Double-acting spool for, e.g. hydraulic motor. Service ports connected to tank (float position) in the neutral position.
- F** Double-acting spool with fourth position in which both service ports are connected to tank (float position). Blocked in the neutral position.

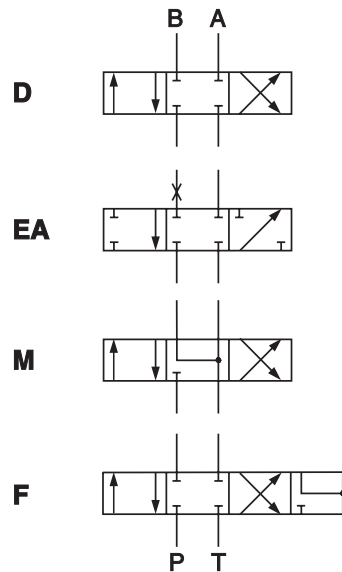

Spool designations

Every spool is given a letter code, which is stamped on the spool. This facilitates identification of the spool when servicing is carried out.

Area relationships

The area relationship for the section in question is calculated by dividing the cylinder area connected to the B-port by the cylinder area connected to the A-port. When the big side of the cylinder is connected to the A-port, the area relationship is less than 1. The area relationship for a motor is 1.

Load characteristics

The lift-load character can be chosen according to four typical cases. This information is needed so that the spool can be adapted optimally for the application in question.

- LAB** Lift load can change between A-port and B-port.
- LA** Lift load normally on A-port only.
- LB** Lift load normally on B-port only.
- LN** Little or no lift load on A- and B-ports.

Load signal system

When a spool is actuated, a signal corresponding to the weight of the load is directed to the LS connection. When both spools are actuated, the greater of the two signals is directed to the LS connection. To enable the signal to be changed, it is drained continuously to tank via the load-signal drainage (LD), at approx. 0.8 l/min.

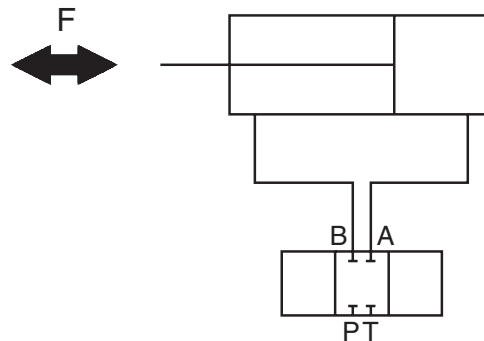

LAB – Lift load can switch between A-port and B-port.

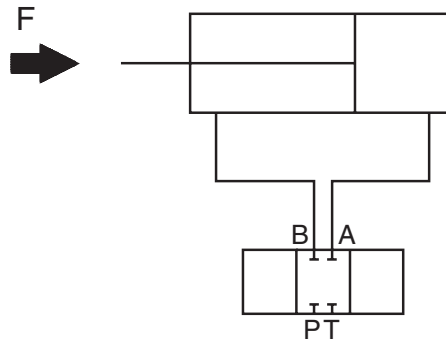

LA – Lift load normally on A-port only.

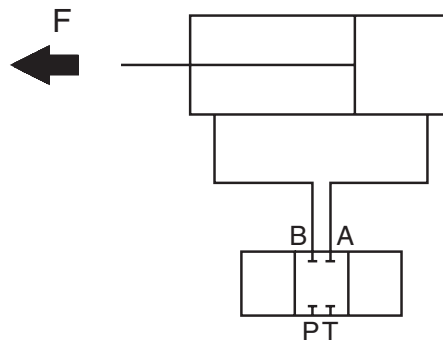

LB – Lift load normally on B-port only.

Spool actuators PC, FPC

The M400LS has pressure operated spools that are controlled via a hydraulic or electro-hydraulic control valve. The flow out of the valve is proportional to the lever stroke. Breakaway is defined by the service port opening to tank, and at full control pressure the spool is located at its outer end position. In the case of float position, a pressure increment is used to move the spool to its fourth position.

Breakaway pressure	6 bar
Final pressure	21 bar
Pressure increment for float position	26 bar

Float position function (FPC)

The valve can be equipped with a float position function in section 2, which blocks the pump flow to the service ports and connects them to tank. The float position is activated by the control pressure for the lowering movement being increased above the max. lowering speed and forcing the spool to a fourth position. The lowering speed increases only marginally in the float position.

Prioritizing function

Section 1 can be pressure prioritized over section 2. This means that if there is a light load on section 2, heavier loads can be handled with section 1, e.g. so that an empty bucket can be tilted up at the same time as the main loading arms are lowered (prioritizing pressure approx. 50 bar). Prioritization is automatic and is controlled via pilot signal logic.

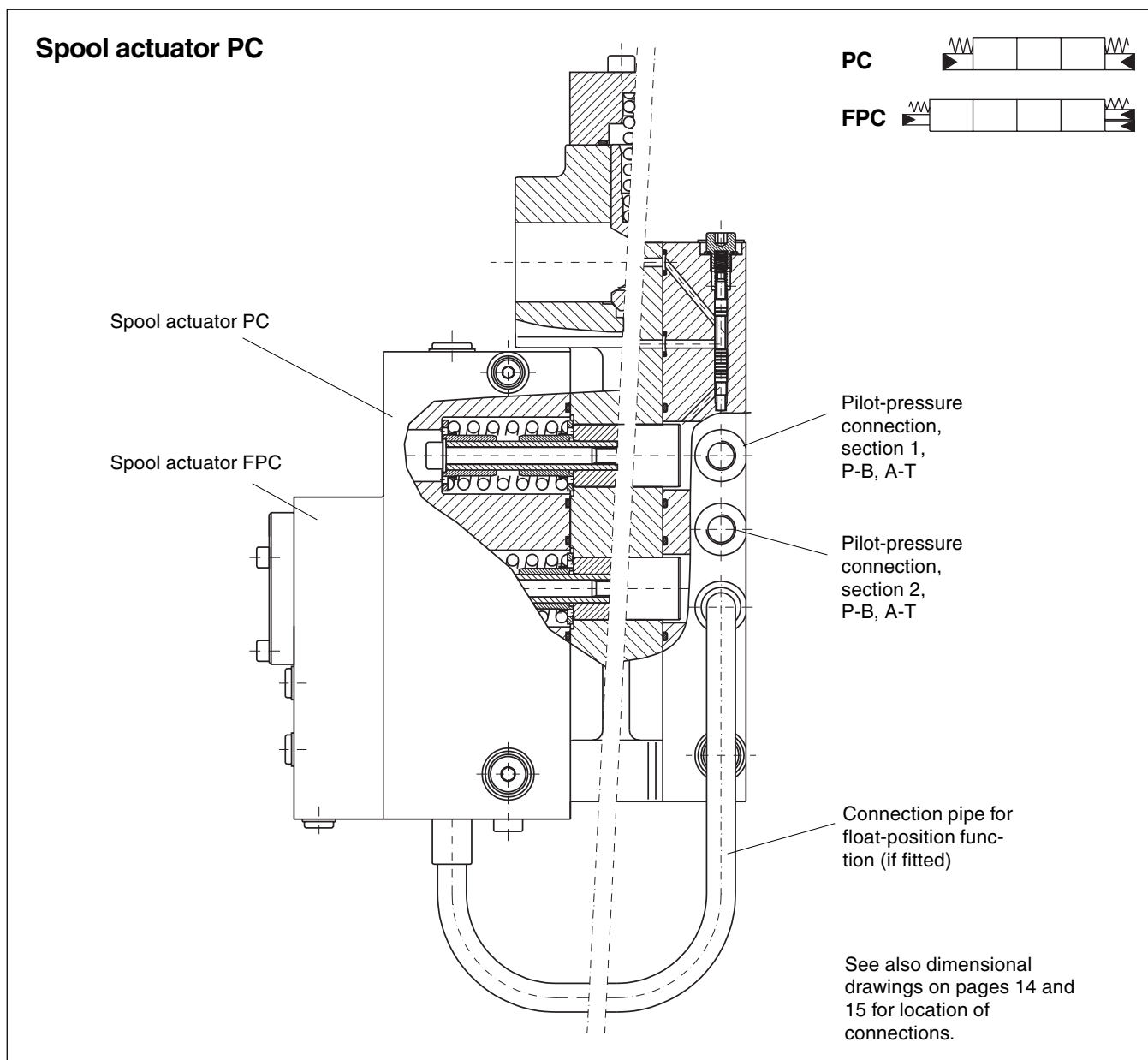

**Pressure limiters in service ports
(Port relief valves)**

The combined port-relief and anti-cavitation valves are renowned for their long service life, high resistance to leakage, quick opening sequence and good characteristics. The valves ensure cavitation-free operation, thus preventing unnecessary shock loading of the system and prolonging the service life of components and seals. The port relief valves are factory set, which guarantees that they always have the right pressure setting.

A very large check-valve area together with spacious galleries and double service ports enables the cylinders to be replenished with low-pressure return oil.

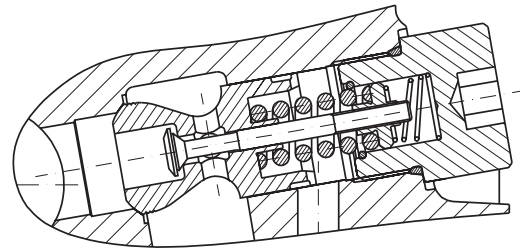

Port relief valve type PA.

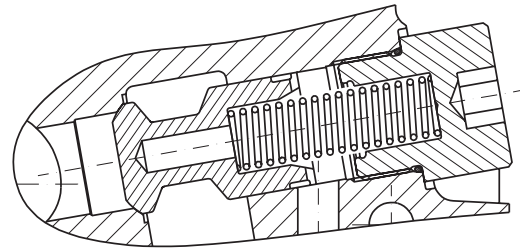

Anti-cavitation valve type N.

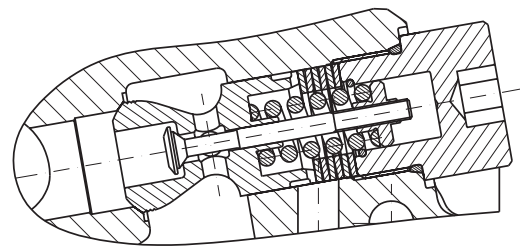

Port relief valve type PAY.

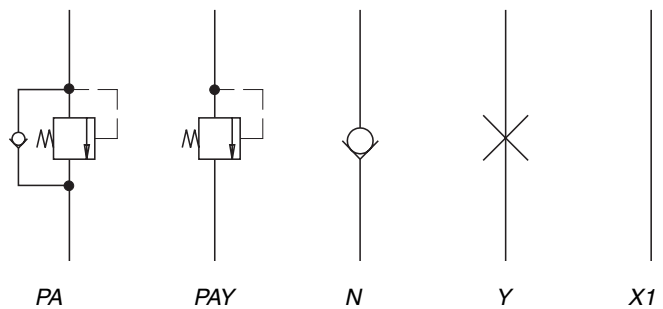

Hydraulic symbols. See also complete circuit diagram on page 8, items 9, 10 and 11.

Port relief valves

- PA** Combined port-relief and anti-cavitation valve fitted. Valve is factory set.
- PAY** Port relief valve without anti-cavitation function fitted. Valve is factory set.
- N** Only anti-cavitation function fitted.
- Y** No port-relief or anti-cavitation valve fitted. Connection service port to tank gallery is blocked.
- X1** No port relief valve fitted. Service port connected to valve's tank gallery.

Pressure settings

Standard settings available: 100, 125, 140, 160, 175, 190, 210, 230, 250, 270, 280, 300, 310, 320, 350, 365, 380, 390 and 400 bar.

Pressure settings are made at a flow of 20 l/min through the valve.

Δp (bar) Port relief valve characteristics

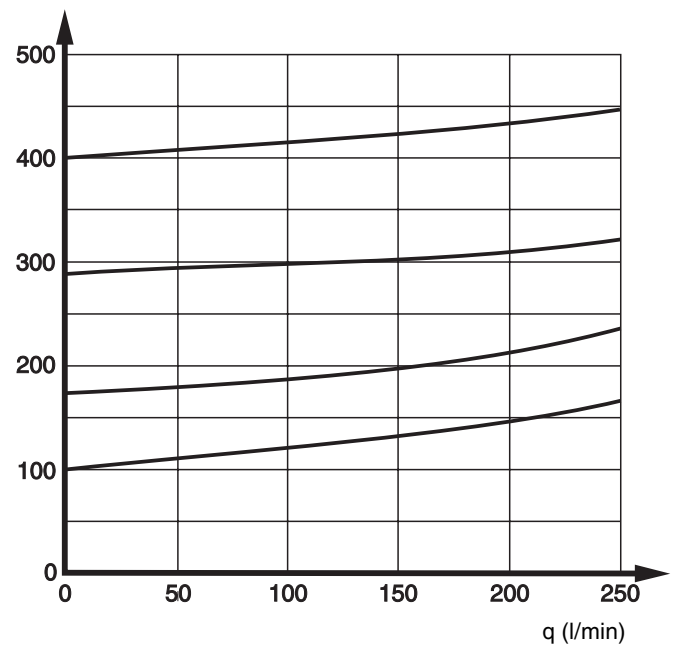

Δp (bar) Anti-cavitation characteristics

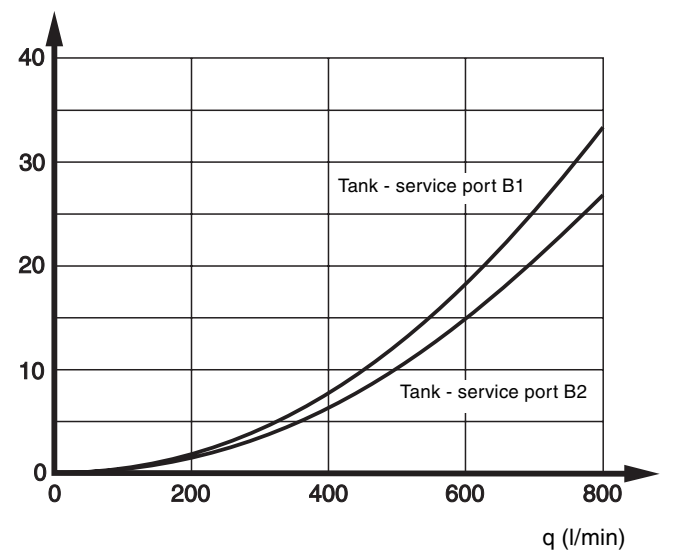

(inch)

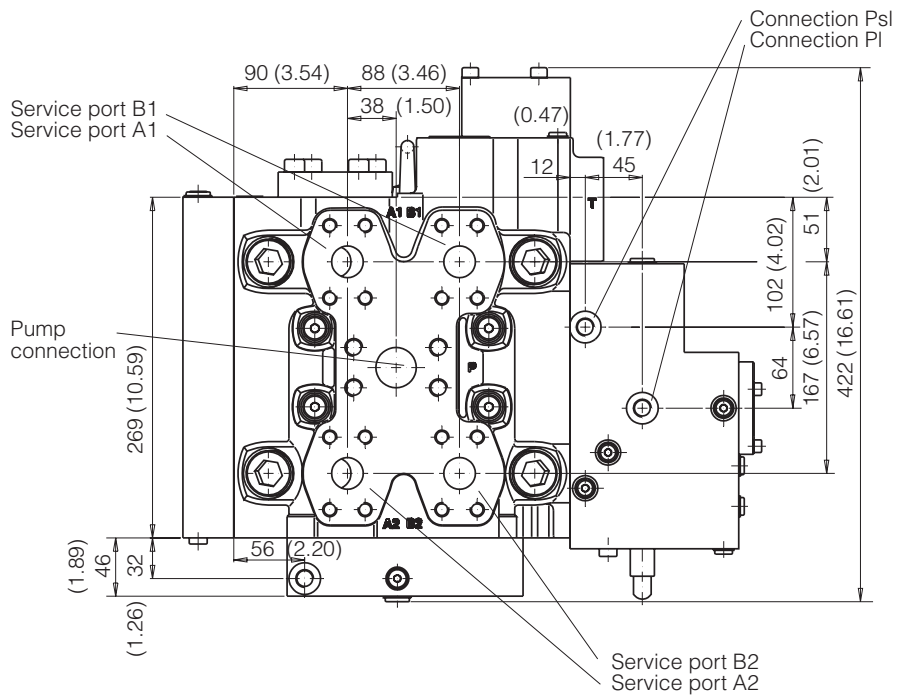
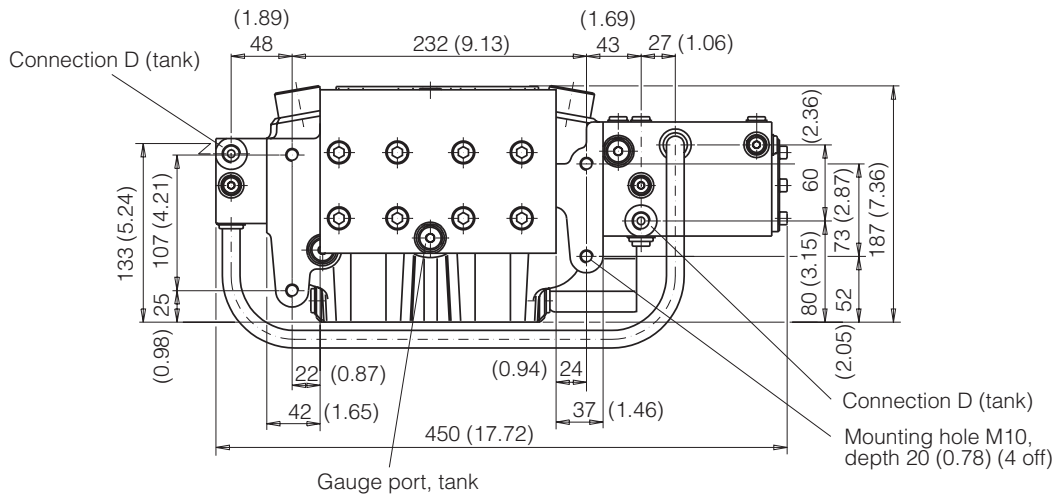

(inch)

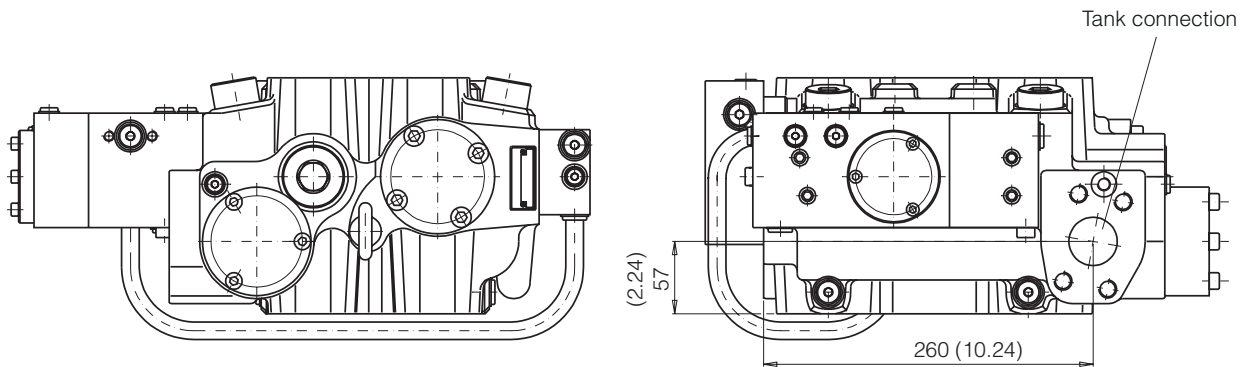
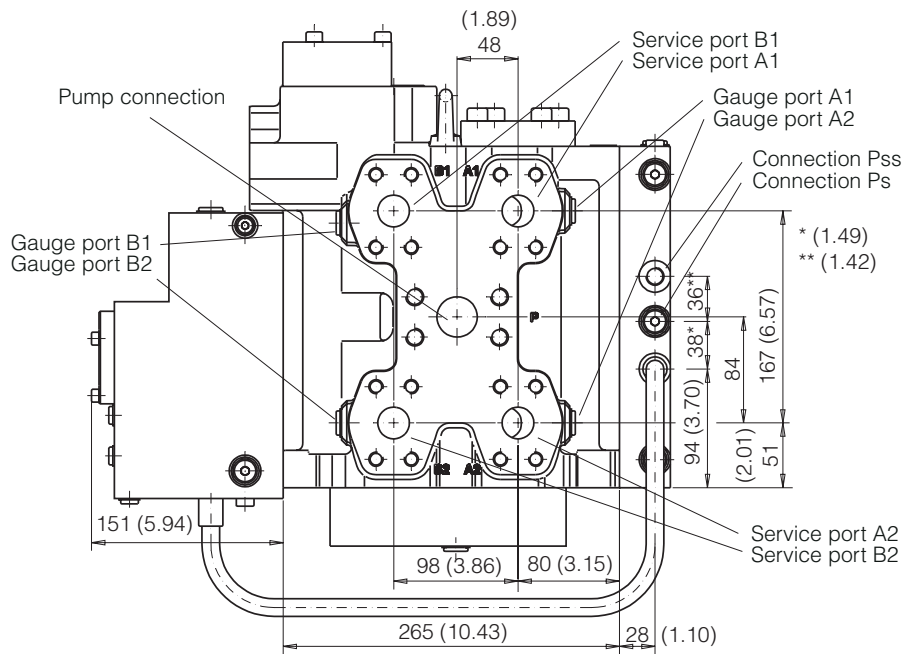

Hydraulics Group Sales Offices

Europe

Austria

Wiener Neustadt
Tel: +43 (0)2622 23501
Fax: +43 (0)2622 66212

Belgium

Nivelles
Tel: +32 (0)67 280 900
Fax: +32 (0)67 280 999

Czech Republic

Klečany
Tel: +420 284 083 111
Fax: +420 284 083 112

Denmark

Ballerup
Tel: +45 4356 0400
Fax: +45 4373 8431

Finland

Vantaa
Tel: +358 (0)9 4767 31
Fax: +358 (0)9 4767 3200

France

Contamine-sur-Arve
Tel: +33 (0)450 25 80 25
Fax: +33 (0)450 03 67 37

Germany

Kaarst
Tel: +49 (0)2131 4016 0
Fax: +49 (0)2131 4016 9199

Hungary

Budapest
Tel: +36 (06)1 220 4155
Fax: +36 (06)1 422 1525

Ireland

Dublin
Tel: +353 (0)1 293 9999
Fax: +353 (0)1 293 9900

Italy

Corsico (MI)
Tel: +39 02 45 19 21
Fax: +39 02 4 47 93 40

The Netherlands

Oldenzaal
Tel: +31 (0)541 585000
Fax: +31 (0)541 585459

Norway

Ski
Tel: +47 64 91 10 00
Fax: +47 64 91 10 90

Poland

Warsaw
Tel: +48 (0)22 863 49 42
Fax: +48 (0)22 863 49 44

Portugal

Leca da Palmeira
Tel: +351 22 9997 360
Fax: +351 22 9961 527

Slovakia

Ref. Czech Republic

Spain

Madrid
Tel: +34 91 675 73 00
Fax: +34 91 675 77 11

Sweden

Spånga
Tel: +46 (0)8 597 950 00
Fax: +46 (0)8 597 951 10

Turkey

Merter/Istanbul
Tel.: +90 212 482 91 06 or 07
Fax: +90 212 482 91 10

United Kingdom

Warwick
Tel: +44 (0)1926 317 878
Fax: +44 (0)1926 317 855

International

Australia

Castle Hill
Tel: +61 (0)2-9634 7777
Fax: +61 (0)2-9899 6184

Canada

Milton, Ontario
Tel: +1 905-693-3000
Fax: +1 905-876-0788

China

Beijing
Tel: +86 10 6561 0520
Fax: +86 10 6561 0526

Asia Pacific Group

Hong Kong, Kowloon
Tel: +852 2428 8008
Fax: +852 2425 6896

India

Mumbai
Tel: +91 22 7907081
Fax: +91 22 7907080

Japan

Tokyo
Tel: +(81) 3 6408 3900
Fax: +(81) 3 5449 7201

Latin America Group

Brazil
Tel: +55 12 3954-5100
Fax: +55 12 3954-5266

South Africa

Kempton Park
Tel: +27 (0)11-961 0700
Fax: +27 (0)11-392 7213

USA

Cleveland (industrial)
Tel: +1 216-896-3000
Fax: +1 216-896-4031
Lincolnshire (mobile)
Tel: +1 847-821-1500
Fax: +1 847-821-7600

Parker Hannifin is the world's premier supplier of motion and control systems and solutions, with sales and manufacturing facilities throughout the world. For product information and details of your nearest Parker sales office, visit us at www.parker.com or call free on 00800 2727 5374.



Catalogue HY17-8535/UK
PDF 12/04

© Copyright 2004
Parker Hannifin Corporation
All rights reserved.