



Directional Control Valve - K220LS

***Proportional, Load-Sensing,
Pressure-Compensated
System Valve***

*Catalogue HY17-8537/UK
December 2004*



Catalog layout

This catalog has been designed to give a brief overview of K220LS valves, and to make it easy for you to study and choose from the different options available, so that we may customize your valve in accordance with your wishes. In addition to general information and basic technical data, the catalog therefore contains descriptions of the options available for various so-called "function areas" of the valve.

Each function area is given as a subheading, followed by a brief description. When options are available for a function area, the subheading is followed by an "Item number" in brackets, e.g. **Pressure relief valve [16]**. This is followed by a series

of coded options, e.g. **PA1, Y1**, together with a brief description of what each code represents. Alternatively, one or more pressure, flow or voltage options are given.

On page 8 is a general circuit diagram showing the basic function areas in a K220LS valve and the item numbers that represent them. Naturally, the same item numbers are used for the respective function areas in all sub-circuit diagrams that appear elsewhere in the catalog. Please note that, unless stated otherwise, all sections and views of the valves have been drawn as seen from the inlet section.

How to order your valve

The K220LS directional control valve can be easily specified using Parker computer programme. This means the customer can optimize his valve specification to give the best performance for his application and specific hydraulic system.

Once the demands placed on each individual function have been specified the computer will select the valve design required to give optimum performance. The computer also produces complete documentation for your valve, in the form of a detailed specification and hydraulic circuit diagram.

The computer also generates a unique identification number for each valve type and customer. The number is then stamped into the I.D. plate of each valve. The specification of your valve is then recorded by Parker, so that exact identification of the product can be made at any time in the future to facilitate repeat ordering or servicing.

Early consultation with Parker saves time and money

Our experienced engineers have in-depth knowledge of the different types of hydraulic system and the ways in which they work. They are at your disposal to offer qualified advice on the best system for the desired combination of functions, control

characteristics and economic demands. By consulting Parker early in the project planning stage, you are assured of a comprehensive hydraulic system that gives your machine the best possible operating and control characteristics.

Conversion factors

1 kg	= 2.2046 lb
1 N	= 0.22481 lbf
1 bar	= 14.504 psi
1 l	= 0.21997 UK gallon
1 l	= 0.26417 US gallon
1 cm ³	= 0.061024 in ³
1 m	= 3.2808 feet
1 mm	= 0.03937 in
9/5 °C + 32	= °F

Table of contents	Page
General Information	4
Technical Data	5
Inlet Section	7
Pressure setting [17]	7
Connections [04] and [47]	8
Mid-inlet section [90-99]	8
Spool Section	8
Spool section with PC spool actuator	8
Feed reducer valve [75]	9
Setting of feed reducer in A-port [75A]	9
Setting of feed reducer in B-port [75B]	9
Dimensional Drawings	10
Mid-inlet section	10

[00] refers to item numbers in the customer specification.

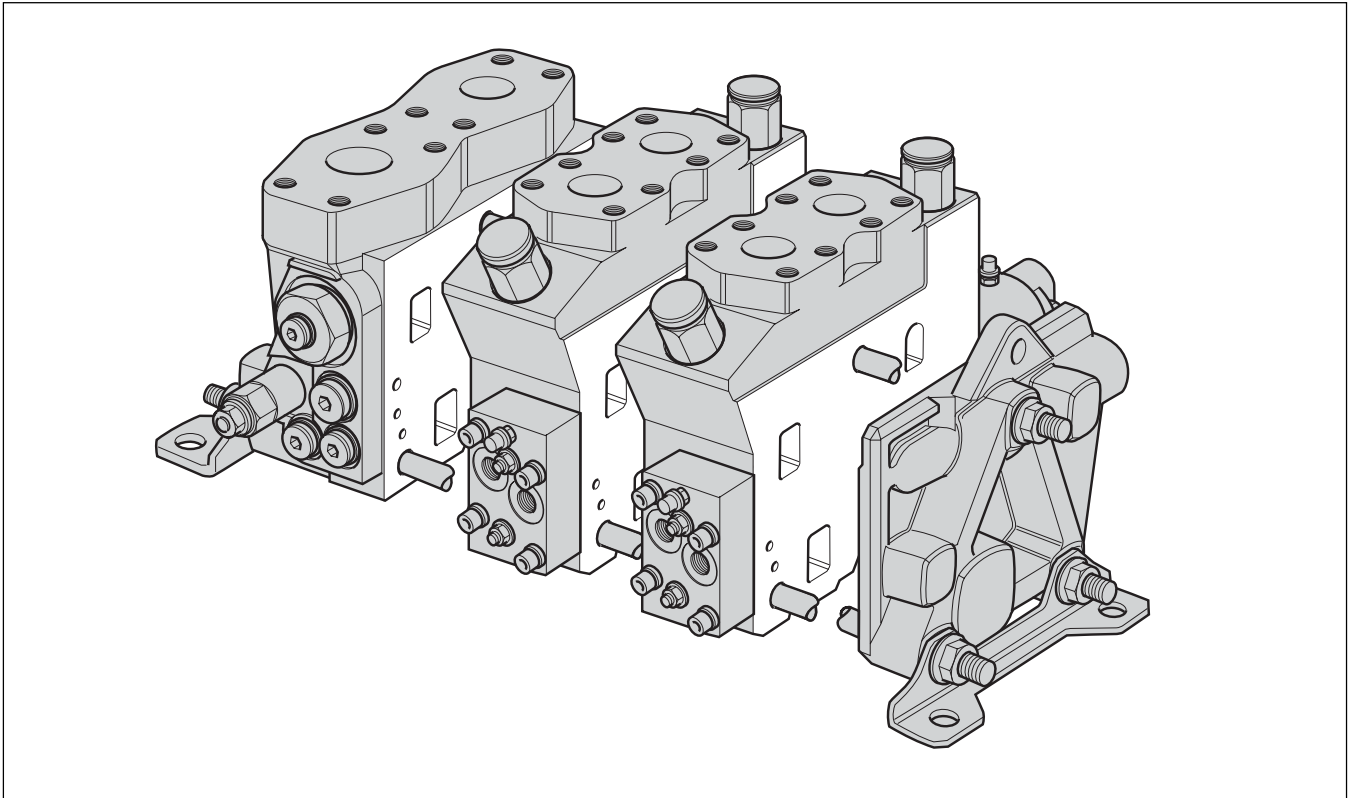

The K220LS is a development of our K170LS directional valve and this leaflet serves only as a complement to the K170LS product catalogue. The numeric codes [00] used in the illustrations and with the sub-headings for specifiable valve functions are therefore the same as those used in the K170LS catalogue and the product specification program SYBER.

Compact system construction

Many system functions can be integrated into the K220LS, reducing the number of components simplifying the installation. By means of an adapter plate, the K220LS can be combined with the smaller L90LS directional valve to serve functions requiring lower flow. This arrangement is very compact and economical.

Freedom in machine design

The K220LS is supplied with spool actuators for either hydraulic or electro-hydraulic proportional remote control. This gives great flexibility in terms of component location and the running of pipework, hoses and electric cables.

Economy

The K220LS can be rebuilt - to increase or reduce the number of spools - at any time to suit the needs of the customer. Moreover, the various valve functions can be adapted to suit the application in question, thus keeping energy consumption to a minimum.

Control characteristics

Thanks to unique function-adapted valve spools, the K220LS gives outstanding control characteristics in both the lifting and lowering movements.

Design

Sectional construction - The K220LS is sectionally built and can be supplied in combinations of 1 to 7 spool sections. It is designed for a system pressure of 350 bar and can be used with pump flows of up to 280 l/min (2 x 280 l/min with mid-inlet section). The nominal maximum flow per spool section is 200 l/min with compensator.

Pressure compensation - An individual pressure compensator in each spool section gives excellent control characteristics.

Feed reducer(s) - Common or individual feed reducers can be adjusted between 30 and 300 bar, limiting the pressure in the respective service ports. Pressure reduction is achieved through the pressure compensator, which shuts off the oil flow.

Force feedback - Force-regulating control characteristics give not only efficient acceleration of swing functions but also more gentle transition in speed changes.

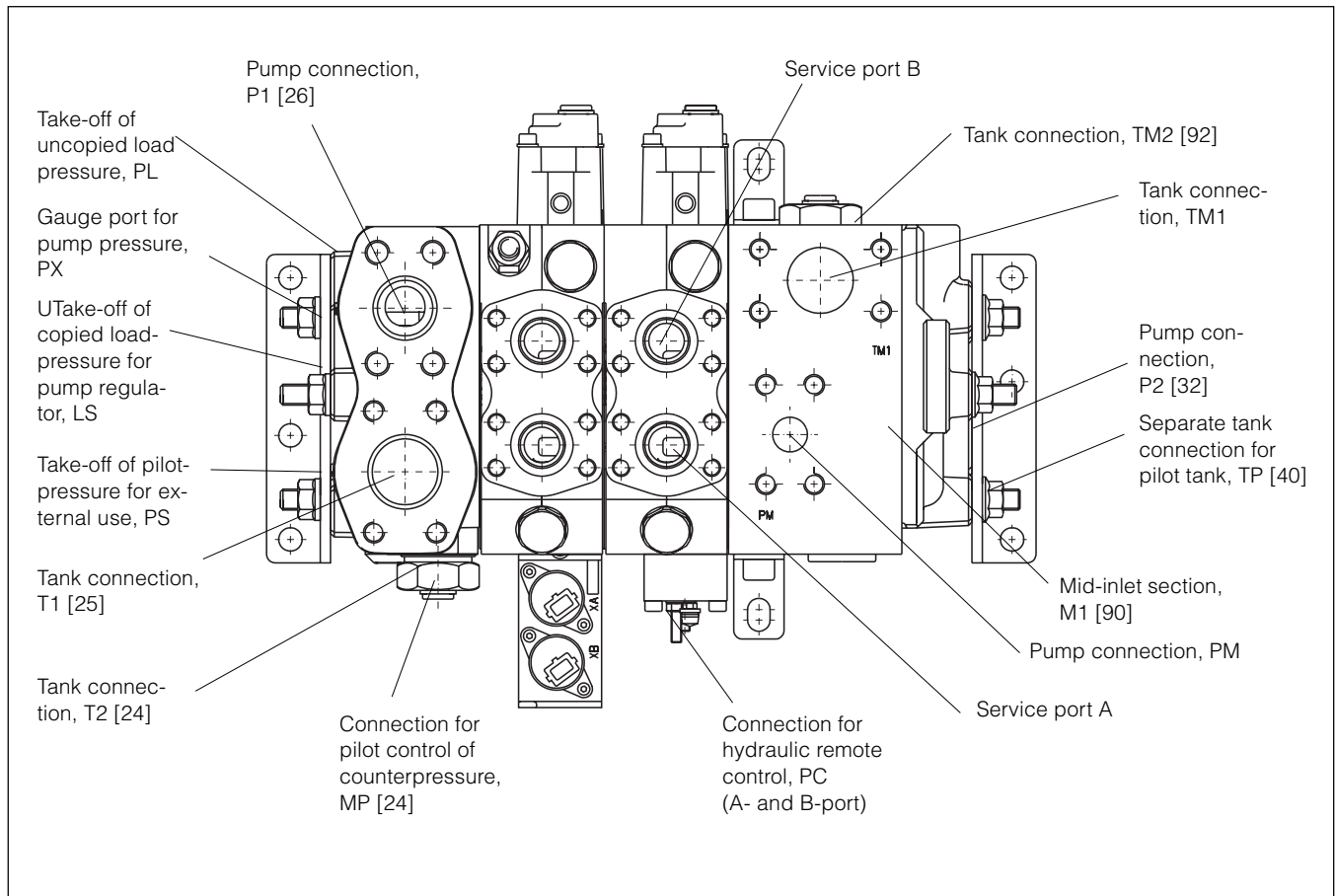

Pressure

Pump inlet	max. 350 bar (5075 psi) ¹⁾
Service ports	max. 350 bar (5075 psi) ¹⁾
Pump regulator	Δp min. 18 bar (260 psi) ²⁾
Compensator K3	Δp min. 30 bar (435 psi) ²⁾
Return line pressure (static)	max. 15 bar (215 psi)

¹⁾ Stated pressures are maximal absolute shock pressures at 10 bar (145 psi) tank pressure
²⁾ Pressure drop from pump to valve max. 3 bar (45 psi)

Temperature

Oil temperature, working range	+20 °C to +90 °C* (68 to 194 °F)
--------------------------------	-------------------------------------

Filtration

Filtration must be arranged so that Target Contamination Class 20/18/14 according to ISO 4406 is not exceeded. For the pilot circuit, Target Contamination Class 18/16/13 according to ISO 4406 must not be exceeded.

Hydraulic fluids

Best performance is obtained using mineral-base oil of high quality and cleanness in the hydraulic system. Hydraulic fluids of type HLP (DIN 51524), oil for automatic gearboxes Type A and engine oil type API CD can be used.

Viscosity, working range 15-380 mm²/s**

Technical information in this catalogue is applicable at an oil viscosity of 30 mm²/s and temperature of 50 °C (122 °F) using nitrile rubber seals.

* Product operating limits are broadly within the above range, but satisfactory operation within the specification may not be accomplished. Leakage and response will be affected when used at temperature extremes and it is up to the user to determine acceptability at these levels.

** Performance efficiency will be reduced if outside the ideal values. These extreme conditions must be evaluated by the user to establish suitability of the products performance.

Technical Data

Weight

The weights given below are approximate, since they vary somewhat depending on valve configuration.

Inlet section	11.4 kg	25.1 lb
Spool section with PC spool actuator	13.1 kg	28.9 lb
Spool section with EC spool actuator	14.5 kg	32.0 lb
End section	4.1 kg	9.0 lb
Adapter plate	8.3 kg	18.3 lb

Connections

P1, PM, T1, TM and the service ports A and B are fitted with so-called flange plane connections according to SAE J518. Fixing screws for the flanges are available in two versions, UNC and metric.

Other connections are available in two versions:

Connection thread type G is for flat seal according to ISO 228/1 (BSP pipe thread).

Connection thread type UN is for O-ring seal according to SAE J 1926/1.

Connect.	Location	Thread
P1	inlet section	Flange 1" (High pressure) ¹⁾
P2	end section	G1 or 1 5/16 - 12 UN-2B
T1	inlet section	Flange 1 1/4" (Std pressure) ³⁾
T2	inlet section	G1 or 1 5/16 - 12 UN-2B
A, B	spool section	Flange 1" (Std pressure) ²⁾
A, B	spool section	Flange 3/4" (High pressure) ²⁾
LS, PL	inlet section	G1/4 alt. 9/16 - 18 UNF-2B
PX, PS	inlet section	G1/4 alt. 9/16 - 18 UNF-2B
MP	inlet section	G1/4 alt. 9/16 - 18 UNF-2B
LSP	end section	G3/8 alt. 9/16 - 18 UNF-2B
T3	end section	G1/4 alt. 9/16 - 18 UNF-2B
PC	spool section	G1/4 alt. 9/16 - 18 UNF-2B
TP	end section	G1/4 alt. 9/16 - 18 UNF-2B
PM	mid-inlet section	Flange 1" (High pressure) ¹⁾
TM	mid-inlet section	Flange 1 1/4" (Std pressure) ¹⁾
TM2	mid-inlet section	G1 or 1 5/16 - 12 UN-2B

¹⁾ Screw M12 or 7/16-14 UNC, depth of thread ≥ 25 mm

²⁾ Screw M10 or 3/8 - 16 UNC, depth of thread ≥ 20 mm

³⁾ Screw M10 or 7/16-14 UNC, depth of thread ≥ 20 mm

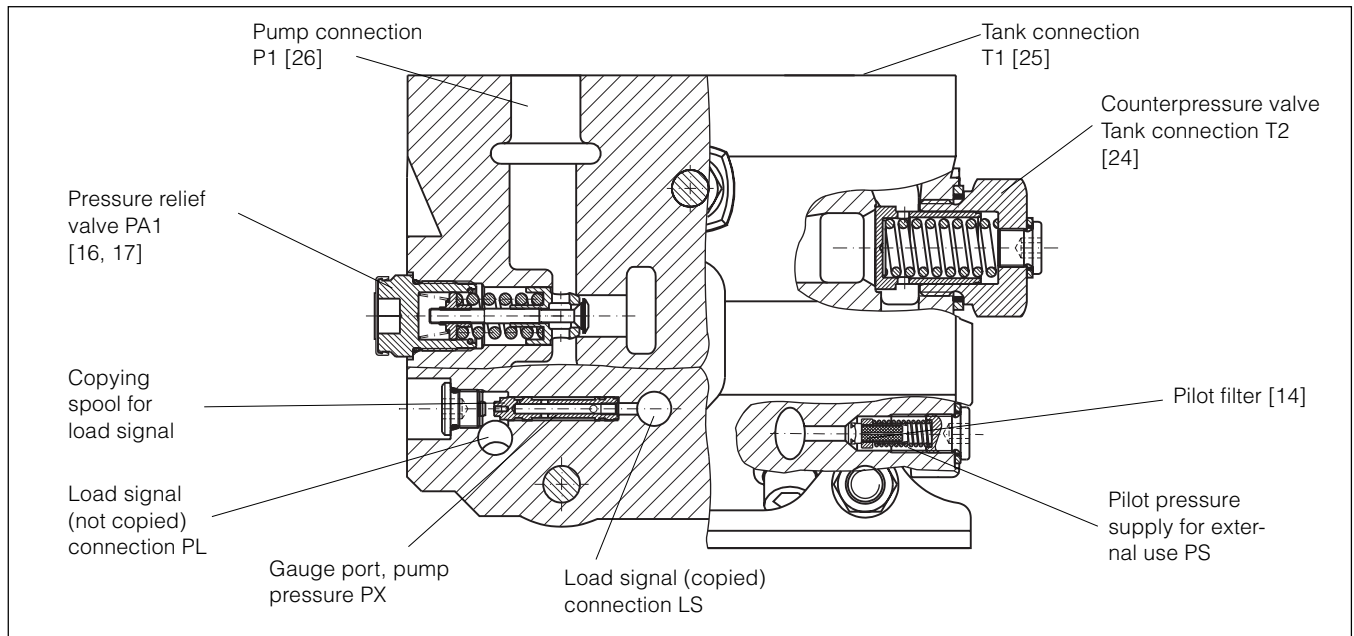

Inlet section [12-29]

The inlet section is equipped with a pump connection (P1) and two tank connections (T1, T2). It is also equipped with connections for a copied load signal to the pump (LS), an uncopied load signal to a subsequent valve (PL), a gauge point for measuring the pump pressure (PX), a take-off of reduced pump-pressure for external pilot-oil supply (PS) and a connection for transmitting the maximum load signal on to a subsequent valve (PL2).

The inlet section also contains a number of other components, e.g. a copying spool for copying the load-signal pressure, a reducer valve with a built-in pressure relief valve for reducing the pump pressure to pilot pressure, a strainer to filter the pilot oil and a pressure relief valve that limits the maximum pressure of the valve. The strainer for the pilot oil can be replaced with an external filter.

- PA1** Direct-acting pressure relief valve PLC183 with very fast opening sequence and good pressure characteristic. The replaceable PLC cartridge is factory set. The cartridge has a replenishing function, which enables oil to flow from the tank gallery to the pump gallery in the event of underpressure in the pump circuit. See "Pressure setting [17]" for pressure values.
- Y1** Plug that replaces the pressure relief valve. The Y1 plug blocks the connection between pump and tank completely.

Pressure setting [17]

Pressure settings for PA1 [16]

The direct-acting pressure relief valve PA1 is delivered factory-set. The following standard pressure settings (in bar) are available: 50, 63, 80, 100, 125, 140, 160, 175, 190, 210, 230, 240, 250, 260, 280, 300, 330 and 350.

PA1 should be set 20 bar above the maximum pressure setting of the pump.

See also technical data on page 5-6.

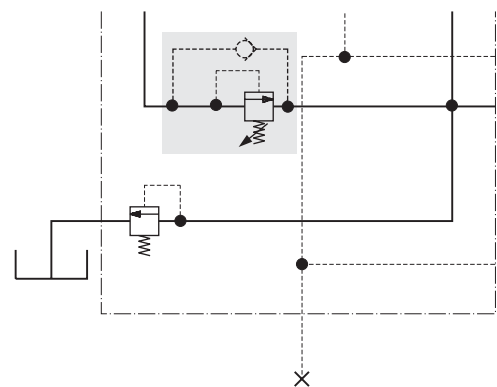

Inlet section with PA1 pressure relief valve.

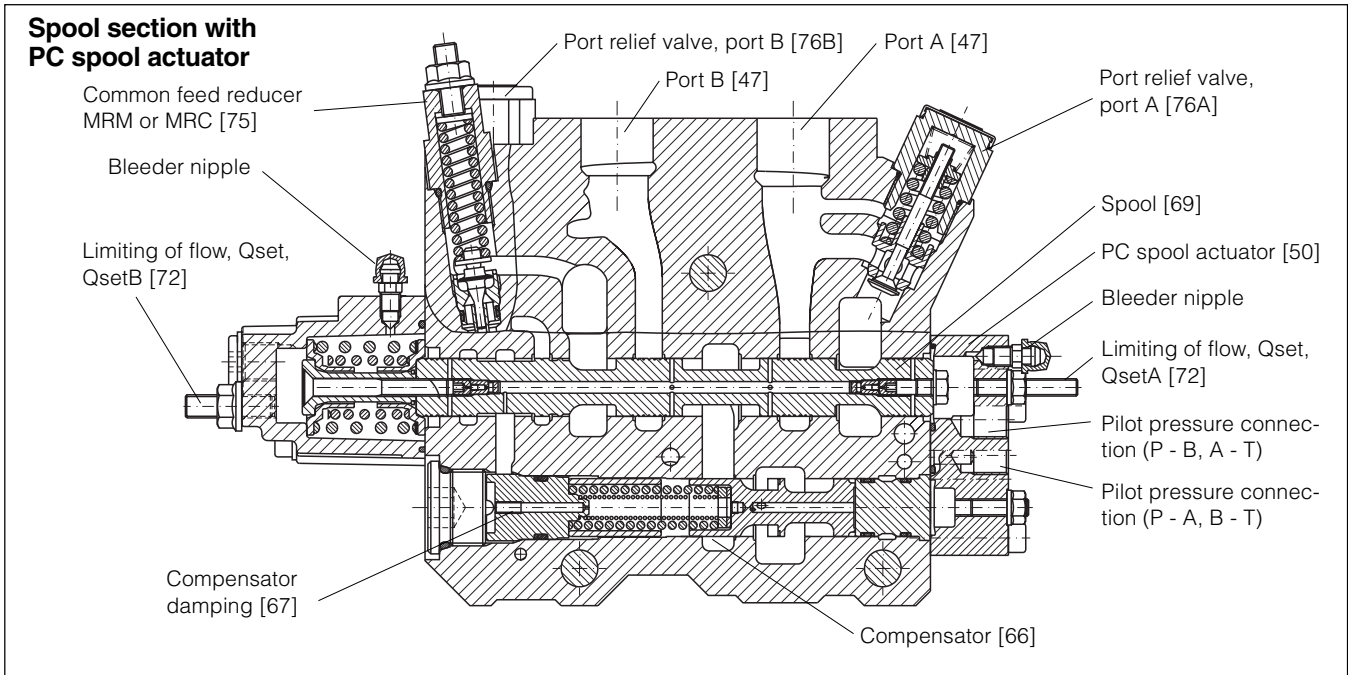

Spool section [45-89]

The K220LS is a stackable directional valve and can be supplied in combinations of 1 to 7 spool sections. Each section can

be equipped individually to incorporate a large number of different functions. By means of function-adapted spools, spool actuators, pressure relief valves, pressure compensators, etc. the valve can be optimized to suit different applications.

Connections [04] and [47]

The section service-port connections are the flange type according to SAE J 518. The fixing-screw threads are available in two versions, UNC and M. Other connections on the section are of G type according to ISO 228/1 (for flat seal) or UN type according to SAE J 1926/1 (for O-ring seal). Please see page 3 for dimensions.

- MG** Flanged connection with M threaded fixing screws. Other connections of G type.
- MU** Flanged connection with M threaded fixing screws. Other connections of UN type.
- UU** Flanged connection with UNC threaded fixing screws. Other connections of UN type.
- FCS** Spool section with service ports A and B according to SAE J518 Standard Pressure.
- FCH** Spool section with service ports A and B according to SAE J518 High Pressure.

Mid-inlet section [90-99]

In certain applications, e.g. the feeding of crawler-track motors on an excavator, there is a demand for high flow from two sections at the same time. This can be achieved by means of the mid-inlet section MI [90], which can be mounted anywhere in the valve. Ideally, however, the high flows should be obtained from the first and last spool sections, and the mid-inlet section should be mounted between the last spool section and the end section.

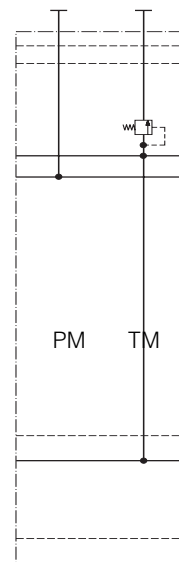

Mid-inlet section with counterpressure valve.

Valves with mid-inlet sections can be fed with a pump flow of 2 x 280 l/min. The mid-inlet section also contains two tank connections or, alternatively, one tank connection and a counterpressure valve (the same counterpressure valve that can be used in T2 [24].) There are two mounting plates on the mid-inlet section, one on each side. These should be used if the valve is to be mounted in any way other than with the service ports facing upward. See dimensional drawing on page 10.

Feed reducer valve [75]

Any section in the K220LS can be equipped with individual feed reduction on service ports A and B.

Feed reduction is used for functions in a system which require a lower maximum pressure than the normal working pressure of the system. The reducer valve is adjustable and reduces the feed pressure in the section to a pre-set level.

By using a feed reducer valve, the feed pressure can be limited without consuming any more than a pilot flow (<2 l/min).

When using the feed reduction function, the section must be equipped with a pressure compensator as the feed reducer is a two-stage valve. Pressure shocks that arise after the feed reducer valve must be limited with the aid of a port relief valve. The pressure setting in the port relief valve [76 A,B] should be as close as possible to that in the feed reducer valve, but at least 10 bar higher.

- MR** Feed reducer for individual setting of maximum pressures in service ports A and B. Pressure settings from 30 to 300 bar.
- MRC** Feed reducer for common setting of maximum pressure in service ports A and B. Pressure settings from 175 to 300 bar.
- MRM** Feed reducer for common setting of maximum pressure in service ports A and B, as well as the service ports in all subsequent sections (seen from the inlet section). Sections located downstream of a section equipped with MRM can be equipped with individual feed reducer valves provided that they are set at lower values. Pressure settings from 175 to 300 bar.

Setting of feed reducer in A-port [75A]

Pressure settings from 30* to 300 bar for A-port.

Setting of feed reducer in B-port [75B]

Pressure settings from 30* to 300 bar for B-port.

* Depending of type of feed reducer.

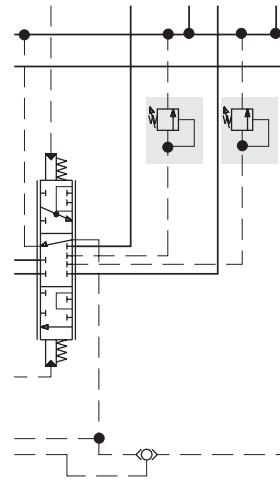

Section equipped with feed reducer valve type MR.

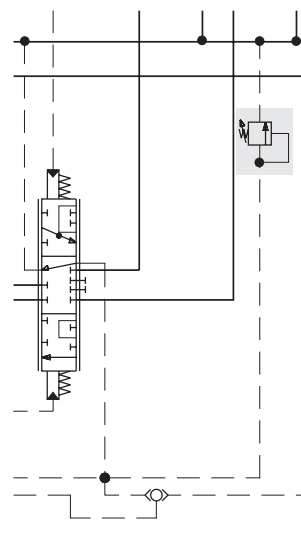

Section equipped with feed reducer valve type MRC.

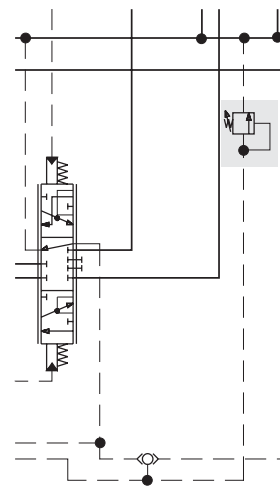

Section equipped with feed reducer valve type MRM.

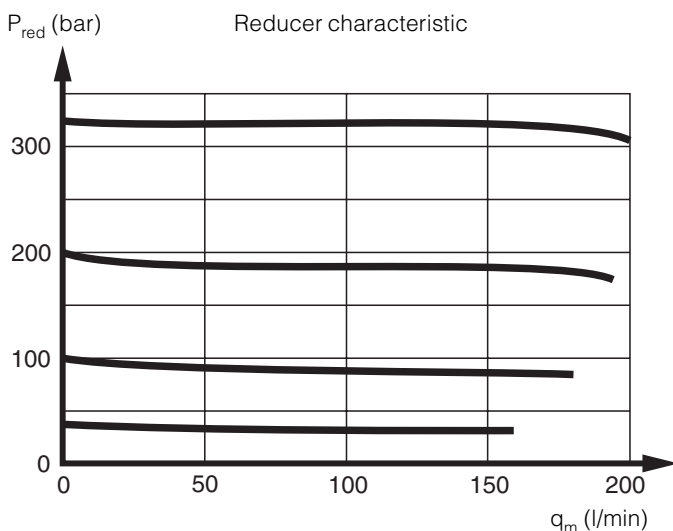

P_{red} = Reduced pressure
 q_m = Flow in service port

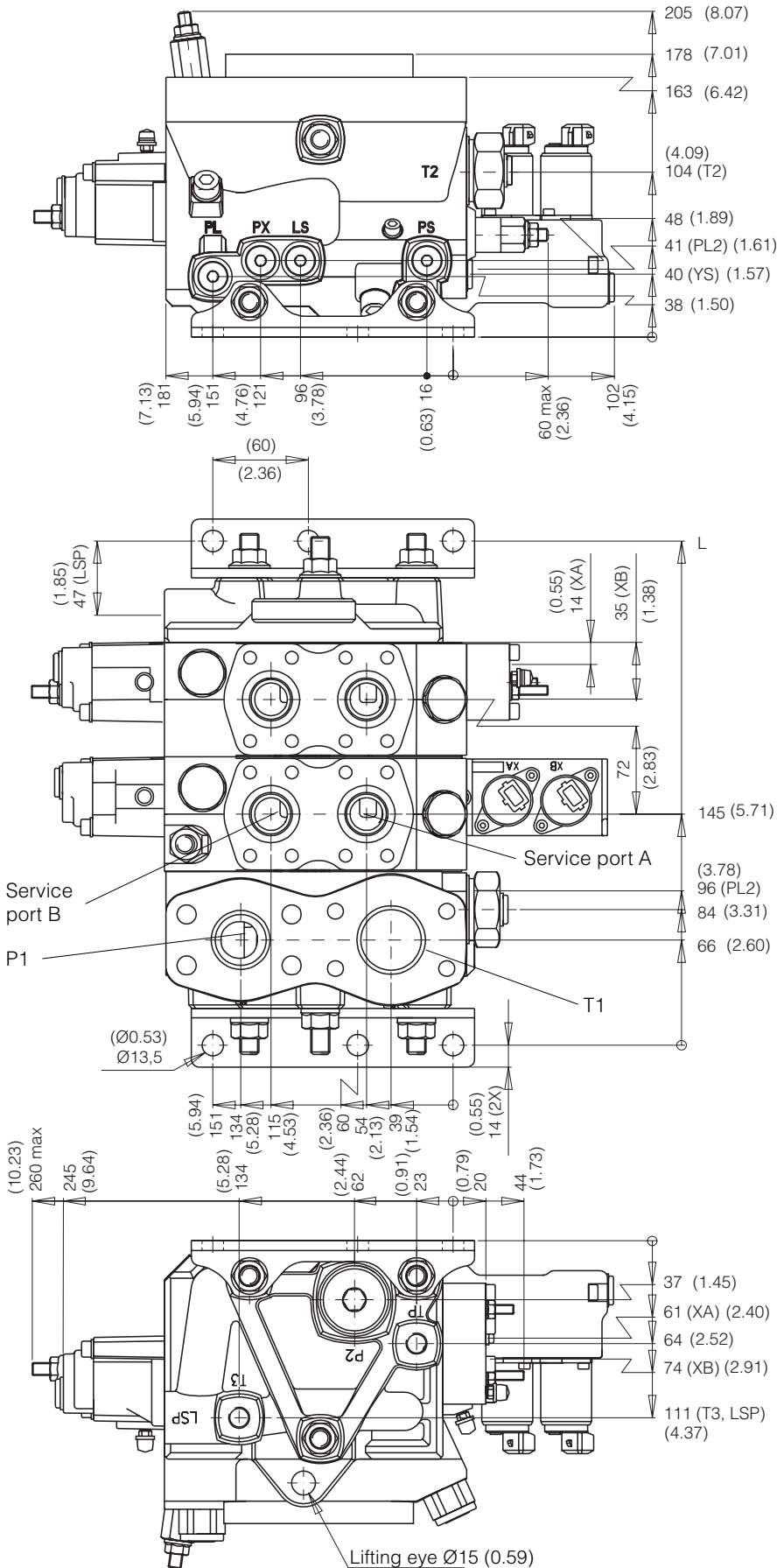

(inch)

No. of sections	L mm	L inch
1	244	9.61
2	316	12.44
3	388	15.28
4	460	18.11
5	532	20.94
6	604	23.78
7	676	26.61

Mid-inlet section

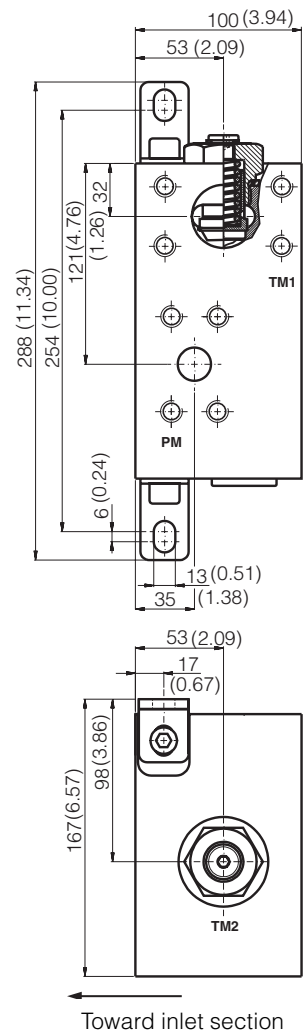



WARNING

FAILURE OR IMPROPER SELECTION OR IMPROPER USE OF THE PRODUCTS AND/OR SYSTEMS DESCRIBED HEREIN OR RELATED ITEMS CAN CAUSE DEATH, PERSONAL INJURY AND PROPERTY DAMAGE.

This document and other information from Parker Hannifin Corporation, its subsidiaries and authorized distributors provide product and/or system options for further investigation by users having technical expertise. It is important that you analyze all aspects of your application, including consequences of any failure, and review the information concerning the product or system in the current product catalogue. Due to the variety of operating conditions and applications for these products or systems, the user, through its own analysis and testing, is solely responsible for making the final selection of the products and systems and assuring that all performance, safety and warning requirements of the application are met.

The products described herein, including without limitation, product features, specifications, designs, availability and pricing, are subject to change by Parker Hannifin Corporation and its subsidiaries at any time without notice.

Offer of Sale

Please contact your Parker representation for a detailed "Offer of Sale".

Hydraulics Group Sales Offices

Europe

Austria

Wiener Neustadt
Tel: +43 (0)2622 23501
Fax: +43 (0)2622 66212

Belgium

Nivelles
Tel: +32 (0)67 280 900
Fax: +32 (0)67 280 999

Czech Republic

Klecany
Tel: +420 284 083 111
Fax: +420 284 083 112

Denmark

Ballerup
Tel: +45 4356 0400
Fax: +45 4373 8431

Finland

Vantaa
Tel: +358 (0)9 4767 31
Fax: +358 (0)9 4767 3200

France

Contamine-sur-Arve
Tel: +33 (0)450 25 80 25
Fax: +33 (0)450 03 67 37

Germany

Kaarst
Tel: +49 (0)2131 4016 0
Fax: +49 (0)2131 4016 9199

Hungary

Budapest
Tel: +36 (06)1 220 4155
Fax: +36 (06)1 422 1525

Ireland

Dublin
Tel: +353 (0)1 293 9999
Fax: +353 (0)1 293 9900

Italy

Corsico (MI)
Tel: +39 02 45 19 21
Fax: +39 02 4 47 93 40

The Netherlands

Oldenzaal
Tel: +31 (0)541 585000
Fax: +31 (0)541 585459

Norway

Ski
Tel: +47 64 91 10 00
Fax: +47 64 91 10 90

Poland

Warsaw
Tel: +48 (0)22 863 49 42
Fax: +48 (0)22 863 49 44

Portugal

Leca da Palmeira
Tel: +351 22 9997 360
Fax: +351 22 9961 527

Slovakia

Ref. Czech Republic

Spain

Madrid
Tel: +34 91 675 73 00
Fax: +34 91 675 77 11

Sweden

Spånga
Tel: +46 (0)8 597 950 00
Fax: +46 (0)8 597 951 10

Turkey

Merter/Istanbul
Tel.: +90 212 482 91 06 or 07
Fax: +90 212 482 91 10

United Kingdom

Warwick
Tel: +44 (0)1926 317 878
Fax: +44 (0)1926 317 855

International

Australia

Castle Hill
Tel: +61 (0)2-9634 7777
Fax: +61 (0)2-9899 6184

Canada

Milton, Ontario
Tel: +1 905-693-3000
Fax: +1 905-876-0788

China

Beijing
Tel: +86 10 6561 0520
Fax: +86 10 6561 0526

Asia Pacific Group

Hong Kong, Kowloon
Tel: +852 2428 8008
Fax: +852 2425 6896

India

Mumbai
Tel: +91 22 7907081
Fax: +91 22 7907080

Japan

Tokyo
Tel: +(81) 3 6408 3900
Fax: +(81) 3 5449 7201

Latin America Group

Brazil
Tel: +55 12 3954-5100
Fax: +55 12 3954-5266

South Africa

Kempton Park
Tel: +27 (0)11-961 0700
Fax: +27 (0)11-392 7213

USA

Cleveland (industrial)
Tel: +1 216-896-3000
Fax: +1 216-896-4031
Lincolnshire (mobile)
Tel: +1 847-821-1500
Fax: +1 847-821-7600

Parker Hannifin is the world's premier supplier of motion and control systems and solutions, with sales and manufacturing facilities throughout the world. For product information and details of your nearest Parker sales office, visit us at www.parker.com or call free on 00800 2727 5374.



Catalogue HY17-8537/UK
PDF 12/04

© Copyright 2004
Parker Hannifin Corporation
All rights reserved.