

Hydraulic Power Units

D, H and V-Pak Series

Catalog 2600-500-1/USA



Introduction



Quick Reference Data Chart

Pump Model No.	Tank Size Gallon (Liters)	Pump Flow GPM (LPM) @ 1725 RPM	Electrical Motors	Maximum * PSI (Bar)
D-Paks	5 (18.9)	0.6 - 2.7 (2.2 - 10.2)	.5 H.P. - 3 H.P.	3000 (207)
H-Paks	10 (37.9), 20 (75.7), 30 (113.6), 40 (151.4)	0.6 - 12.7 (2.2 - 48.0)	.5 H.P. - 20 H.P.	3000 (207)
V-Paks	10 (37.9), 20 (75.7), 30 (113.6), 40 (151.4)	2.0 - 15.6 (7.6 - 59.1)	2 H.P. - 20 H.P.	3000 (207)

* See pump/motor combination, maximum pressure charts.

Technical Information

Warranty

The hydraulic components on these Parker Power Units are warranted for one year. This warranty may be extended to two years by using and properly maintaining Parker filters.

Installation Data:

See Installation/Maintenance Manual for specific recommendations pertaining to start-up, system cleanliness, fluids, temperature and other important factors relative to proper installation and use of these power units.



Standard Features

- Vertical Design
- Submerged Pump
- Precision Pump Mounting Adapters
- Suction Strainer
- Glycerine Filled Pressure Gage with Shut Off
- Oil Level Gage with Thermometer
- Relief Valve
- Breather and Fill Cap
- SAE Drain Plug

Benefits

- Saves Floor Space
- Quieter Operation, Elimination of Potential Leak Point
- Longer Pump Life
- Protects Pump from Contamination
- Improved Diagnostics
- Helps to Maintain Trouble-Free Performance
- Protects Against System Shock
- Easy To Fill Reservoir
- Prevents Leaks

Schematic Symbol

(Hydraulic Schematic - Basic Unit)

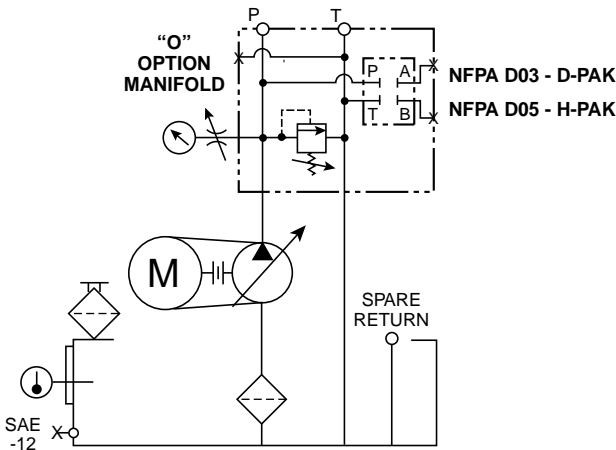

D & H-PAK BASIC UNIT
 NO OPTIONS OR ACCESSORIES
 "O" OPTION MANIFOLD

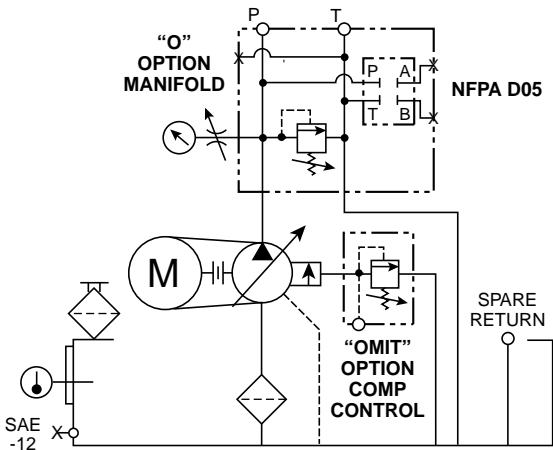

V-PAK BASIC UNIT
 NO OPTIONS OR ACCESSORIES
 "OMIT" OPTION PUMP COMPENSATOR
 "O" OPTION MANIFOLD

Installation Information

Dimensions - Basic H2, 3, 4 & V2, 3, 4 (20, 30, 40 Gallon Tank)

Millimeter equivalents for inch dimensions are shown in (**).

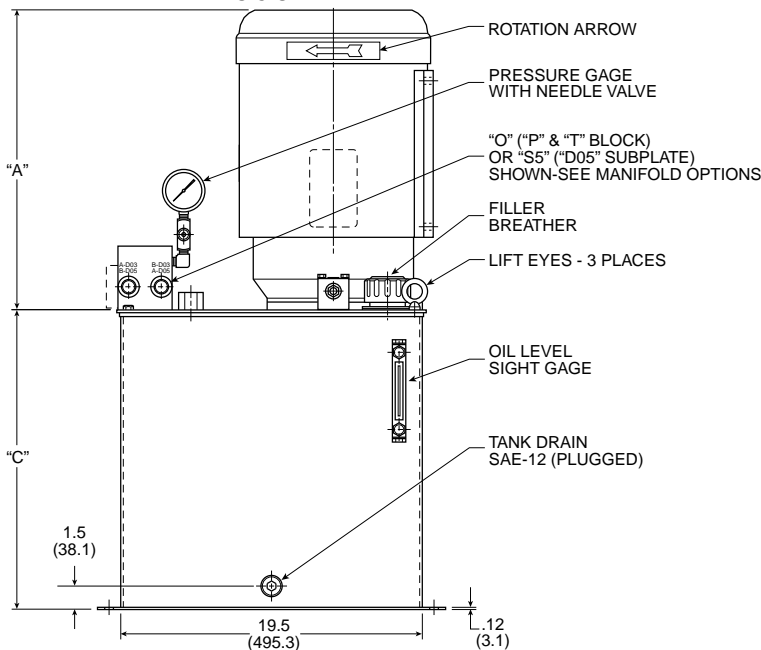
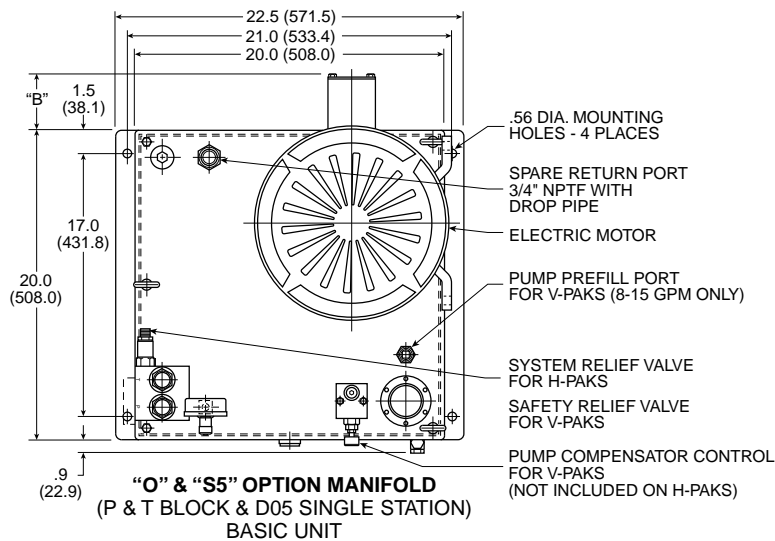

Motor Code	Motor Description HP-RPM-Frame-Phase	Dimension	
		“A”	“B”
U1	.5 -1725-56C-1	10.50 (266.70)	.75 (19.05)
C1	.75 -1725-56C-1	11.00 (279.40)	.75 (19.05)
T1	1 -1725-56C-1	11.75 (298.45)	.75 (19.05)
T3	1 -1725-56C-3	10.50 (266.70)	.75 (19.05)
F	1.5 -1725-56C-3	10.75 (273.05)	.75 (19.05)
G	2 -1725-56C-3	11.75 (298.45)	.75 (19.05)
K	3 -1725-56C-3	12.62 (320.55)	.75 (19.05)
L	5 -1725-184TC-3	14.38 (365.25)	1.13 (28.70)
M	7.5 -1725-213TC-3	16.00 (406.40)	1.38 (35.05)
N	10 -1725-215TC-3	16.28 (413.51)	1.38 (35.05)
P	15 -1725-254TC-3	17.63 (447.80)	3.35 (85.09)
S	20 -1725-256TC-3	19.38 (492.25)	3.35 (85.09)

Reservoir Code	Reservoir Size	Dimension “C”
H2 or V2	20 Gallon	19.36 (491.74)
H3 or V3	30 Gallon	23.62 (599.95)
H4 or V4	40 Gallon	28.86 (733.04)

Filter Option Reference

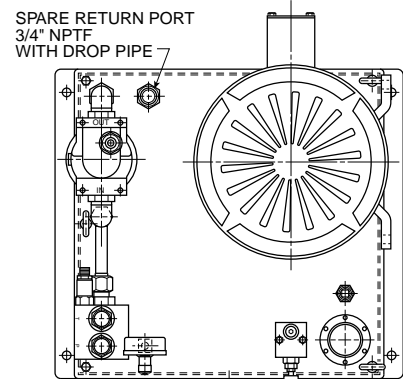

“O” & “S5” OPTION MANIFOLD (P & T BLOCK & D05 SINGLE STATION) SHOWN WITH OPTION “N” RETURN FILTER

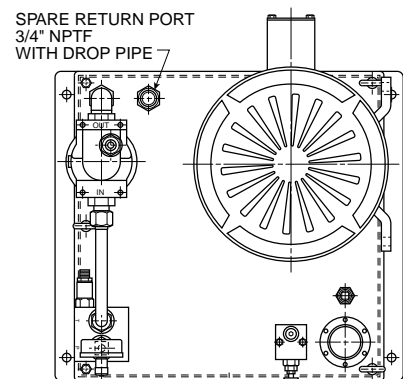
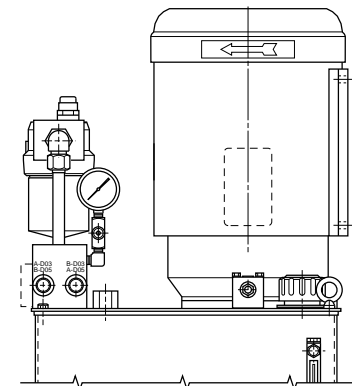

“M5” OPTION MANIFOLD (MULTI-STATION D05 MANIFOLD) SHOWN WITH OPTION “N” RETURN FILTER

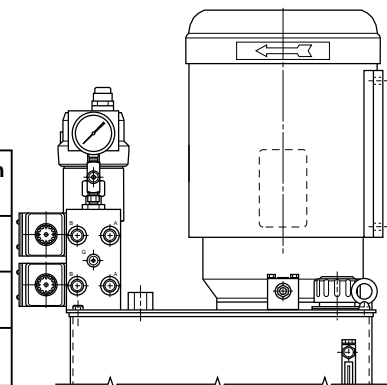

Technical Information

Manifold Options

Millimeter equivalents for inch dimensions are shown in (**).

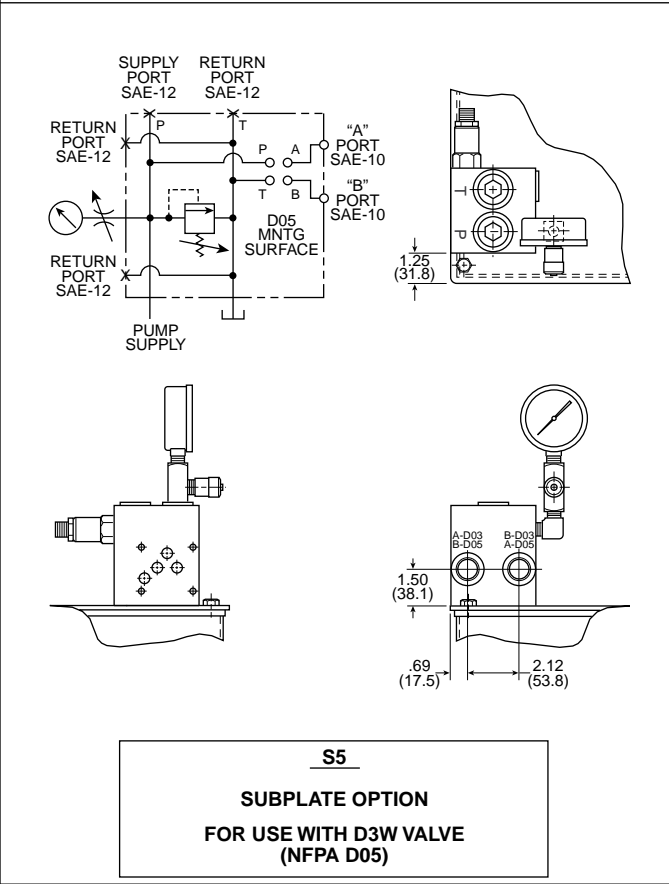
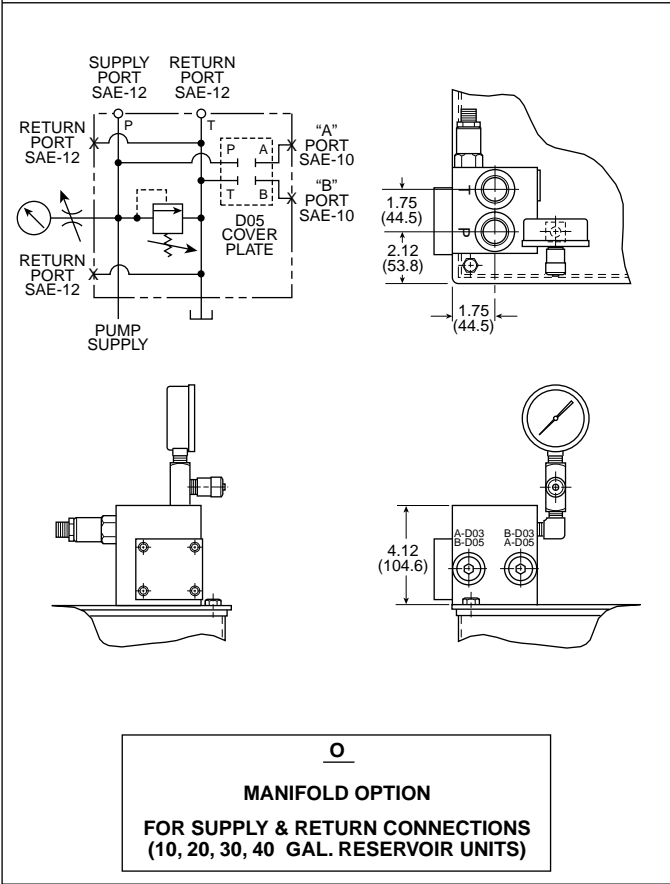
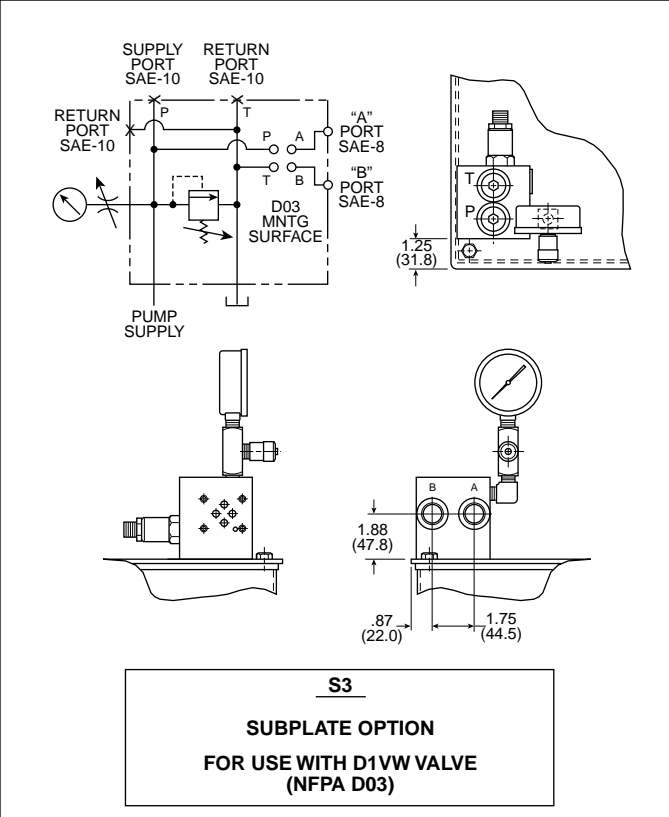
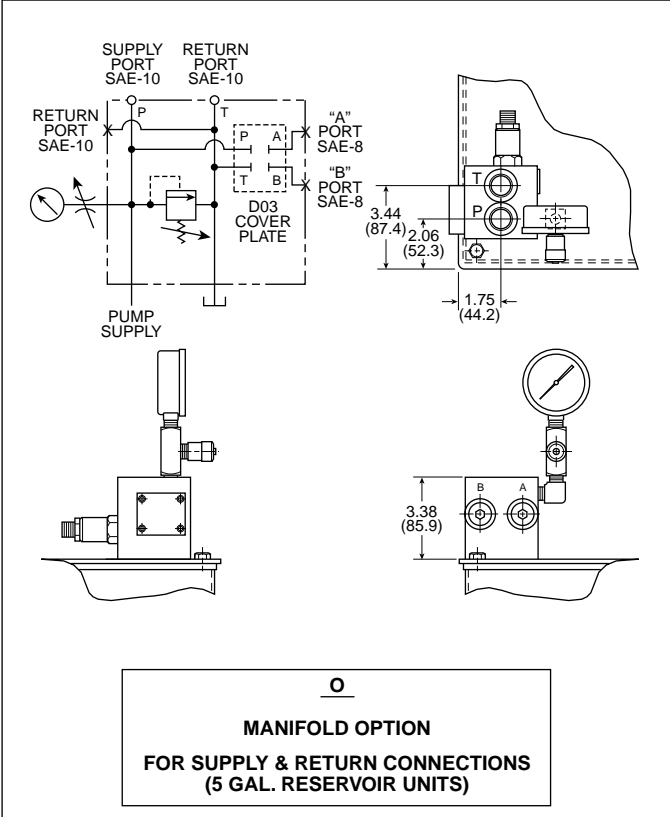

Technical Information

Manifold Options

Millimeter equivalents for inch dimensions are shown in (**).

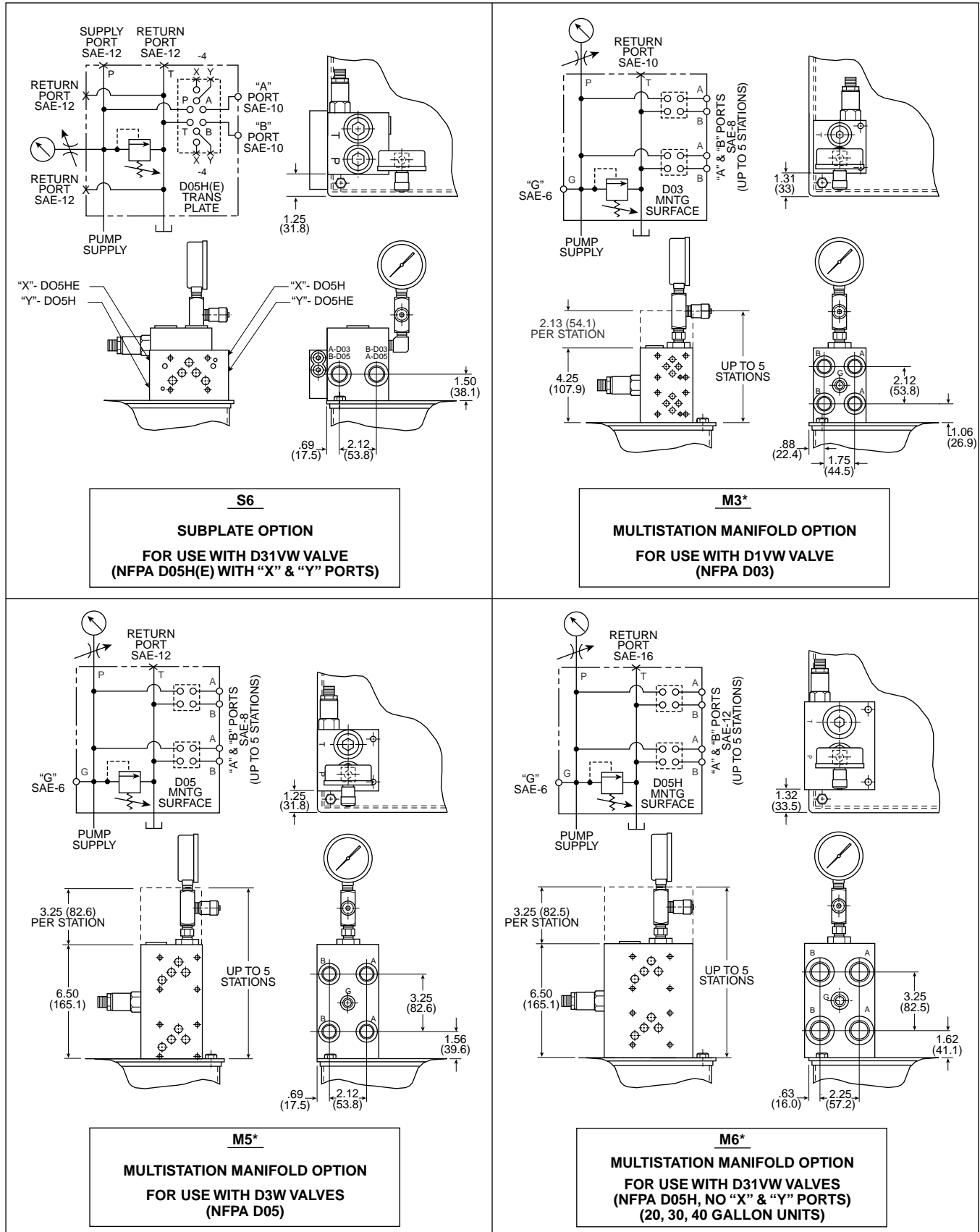

Technical Information

Dimensions - H2, 3, 4 & V2, 3, 4 (20, 30, 40 Gallon Tank) Accessories

Millimeter equivalents for inch dimensions are shown in (**).

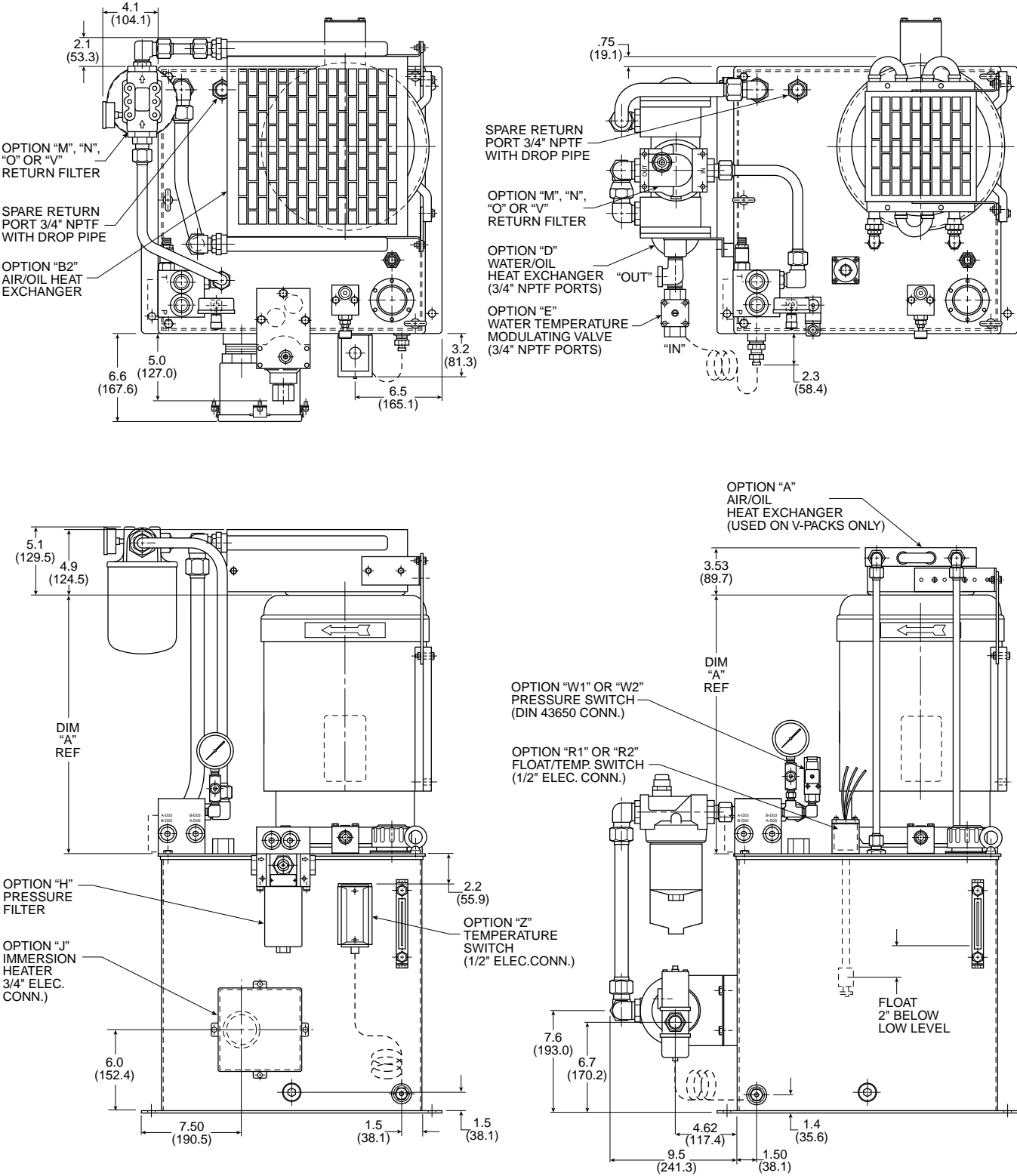

Technical Information

Performance Data – Maximum Working Pressures

**** Represents maximum operating pressure with pump/motor combination. This will be the maximum relief valve or compensator setting.

**** Represents maximum operating pressure with pump/motor combination. When used on power unit products this will represent a 3000 PSI relief valve or compensator setting.

D & H-Pak - Pump/Motor Combinations Maximum Operating Pressure

Pump Code Flow at 1725 RPM	Motor Horsepower										
	.5	.75	1	1.5	2	3	5	7.5	10	15	20
	Max Operating Pressure (Theoretical)										
0.6	1140	1700	2280	3420							
0.9	810	1220	1620	2430	3240						
1.2	630	940	1260	1880	2510	3770					
1.8	430	640	860	1280	1720	2570	4280				
2.3	330	500	670	1000	1340	2010	3350				
2.7	290	440	580	870	1170	1750	2920	4370			
3.2	230	350	460	700	930	1400	2330	3500			
4.3	170	260	350	520	700	1050	1750	2630	3500		
5.1	150	220	300	440	590	890	1480	2220	2960	4430	
6.3	120	180	240	360	480	720	1200	1800	2400	3600	
8.1	90	140	180	270	360	540	910	1360	1820	2720	3640
9.4	80	120	160	240	310	470	780	1180	1570	2350	3130
12.7	60	90	120	170	230	350	580	870	1160	1740	2320

V-Pak - Pump/Motor Combinations Maximum Operating Pressure

Pump	GPM @ 1725 RPM	Motor Horsepower						
		2	3	5	7.5	10	15	20
PVP16	2.0	1050	1570	2600	3860			
PVP16	2.5	930	1370	2250	3370			
PVP16	3.0	830	1230	2000	3000			
PVP16	3.5	750	1100	1800	2680	3570		
PVP16	4.0	680	1000	1650	2440	3240		
PVP16	4.5	630	920	1500	2230	2970	4430	
PVP16	5.0	580	850	1400	2060	2740	4080	
PVP16	5.5	550	800	1300	1920	2540	3790	
PVP16	6.0	510	750	1210	1790	2370	3540	
PVP16	6.5	480	700	1130	1680	2220	3310	
PVP16	7.0	450	660	1070	1580	2100	3120	
PVP33	8.0		600	960	1420	1880	2800	3700
PVP33	8.5		570	930	1350	1790	2650	3520
PVP33	9.0		540	880	1290	1700	2530	3350
PVP33	9.5		520	840	1230	1630	2410	3200
PVP33	10.0		500	800	1180	1550	2310	3000
PVP33	10.5		480	770	1130	1490	2210	2940
PVP33	11.0		460	740	1090	1430	2130	2820
PVP33	11.5		450	710	1050	1380	2050	2710
PVP33	12.0		430	690	1010	1330	1970	2610
PVP33	12.5		420	670	970	1280	1900	2520
PVP33	13.0		410	650	940	1240	1840	2430
PVP33	13.5		390	630	910	1200	1780	2350
PVP33	14.0		380	610	880	1160	1720	2280
PVP33	14.5		370	590	860	1130	1670	2210
PVP33	15.0		360	570	830	1090	1620	2140

Performance Data – Pumps

Standard Pumps

PVP16 @ 1800 RPM

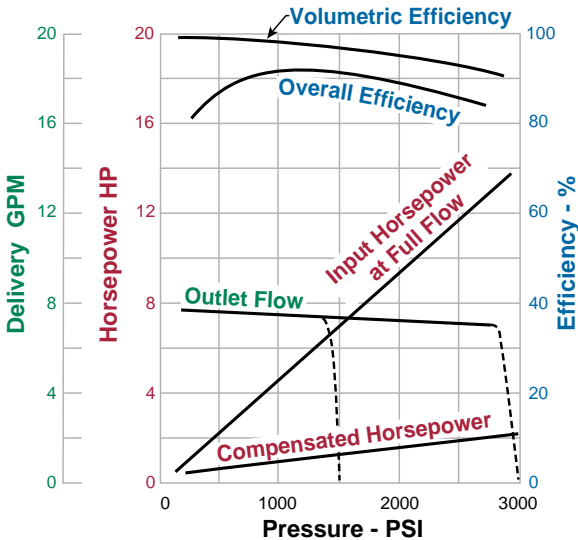

PVP33 @ 1800 RPM

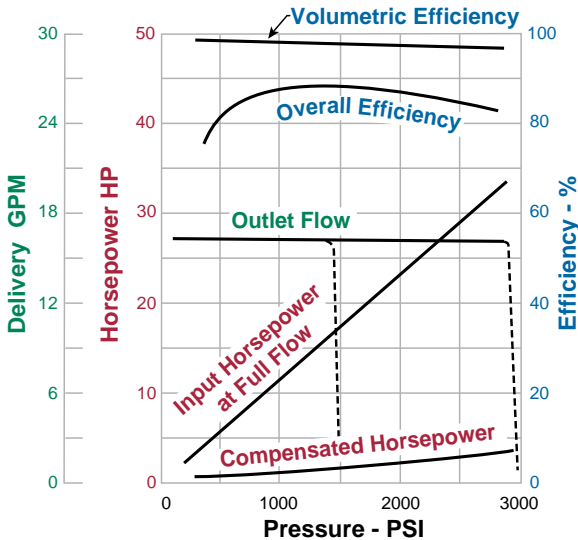

NOTE: The efficiencies and data in the graph are good only for pumps running at 1800 RPM and stroked to maximum. To calculate approximate horsepower for the other conditions, use the following formula:

$$HP = \left[\frac{Q \times (PSI)}{1714} \right] + (CHp) \times \frac{N}{1800}$$

Actual GPM is directly proportional to drive speed and maximum volume setting. Flow loss, however, is a function of pressure only.

WHERE:

- Q = Actual Output Flow in GPM
- PSI = Pressure At Pump Outlet
- CHp = Input Horsepower @ Full compensation @ 1800 RPM (from graph read at operating pressure)
- N = Drive Speed in RPM

Horsepower Limited Pumps

PVP16 @ 1800 RPM

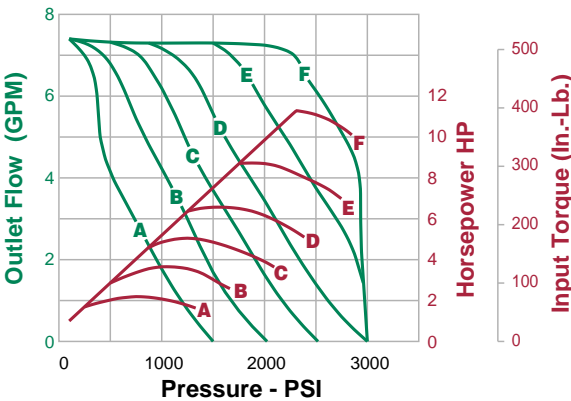

	MOTOR HP					
	2	3	5	7.5	10	15
PVP16 FULL STROKE	1400	1950	2500	3000	3000	3000

Pump Control Option "H" with PVP16
Horsepower Limiting
Factory Compensator Settings

PVP33 @ 1800 RPM

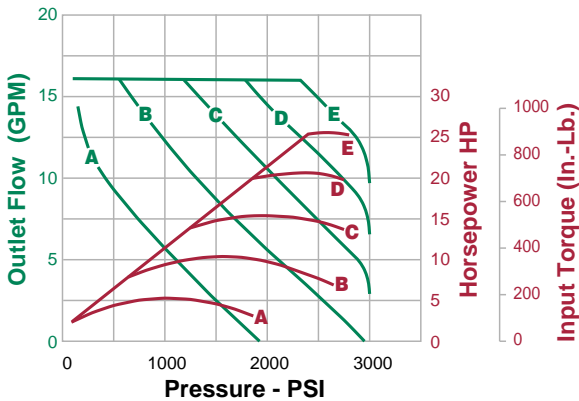

	MOTOR HP				
	5	7.5	10	15	20
PVP33 FULL STROKE	1900	2400	2900	3000	3000

Pump Control Option "H" with PVP33
Horsepower Limiting
Factory Compensator Settings

Performance Data – Heat Exchangers

Air/Oil Heat Exchangers

“A”, “B1” & “B2” used with 1800 RPM TEFC Motors

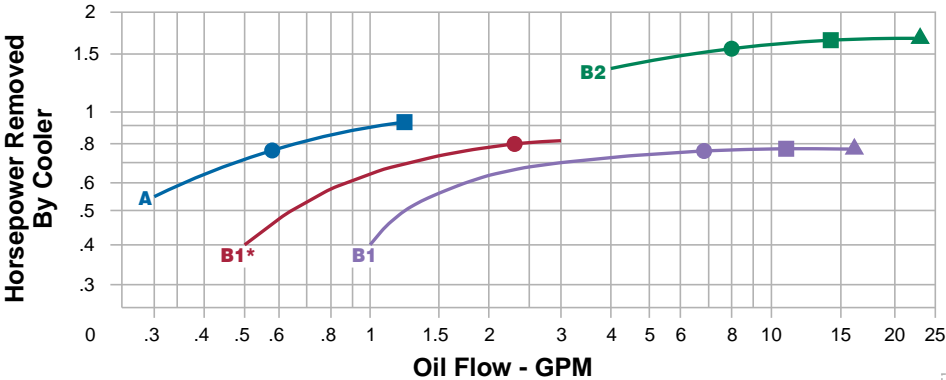

- “A” - Pump Case HT. EX. with 56C-256TC Motors
- “B1*” - Return Line HT. EX. (D5 Power Units Only)
- “B1” - Return Line HT. EX. with 56C-184TC Motors
- “B2” - Return Line HT. EX. with 213TC-256TC Motors

Heat removal is based on 40°F differential between transfer medium.

Oil Pressure Drop at 100 SSU

- = 5 PSI
- = 10 PSI
- ▲ = 20 PSI

Water/Oil Heat Exchangers

“C” (1:1 Oil/Water Ratio) “D” (2:1 Oil/Water Ratio)

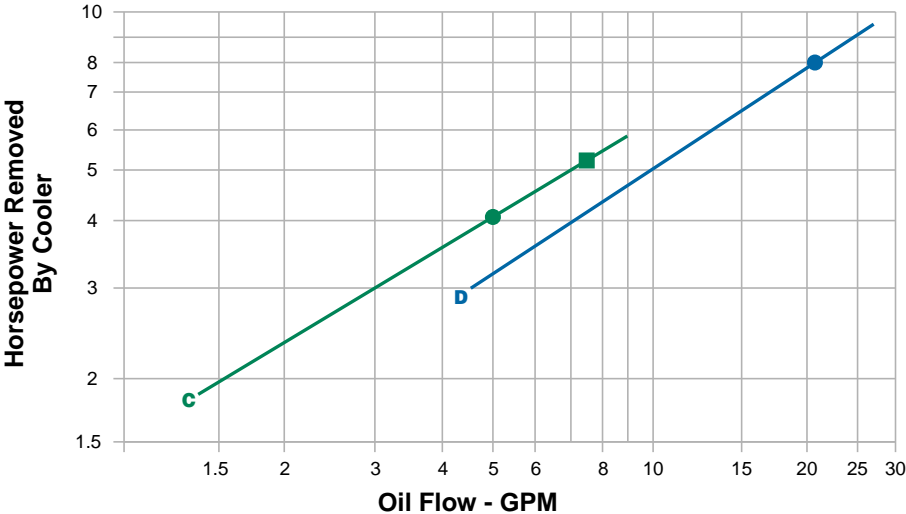

- “C” - Return Line HT. EX. (9 GPM Max.)
- “D” - Return Line HT. EX. (4.5 GPM Min.)

Heat removal is based on 40°F differential between transfer medium, using 85°F cooling water.

The Oil/Water ratio of 2:1 means that for every 2 gallons of oil through the cooler, a minimum of 1 gallon of 85°F water must be circulated to achieve curve results.

Oil Pressure Drop at 100 SSU

- = 5 PSI
- = 10 PSI

Horsepower Removed By Reservoir

	RESERVOIR SIZE (GALLONS)				
	5	10	20	30	40
HP REMOVAL	0.2	0.38	0.58	0.68	0.81

Heat removal is based on static ambient air at 85°F and max. oil temperature of 135°F.

Ordering Information

H-Paks

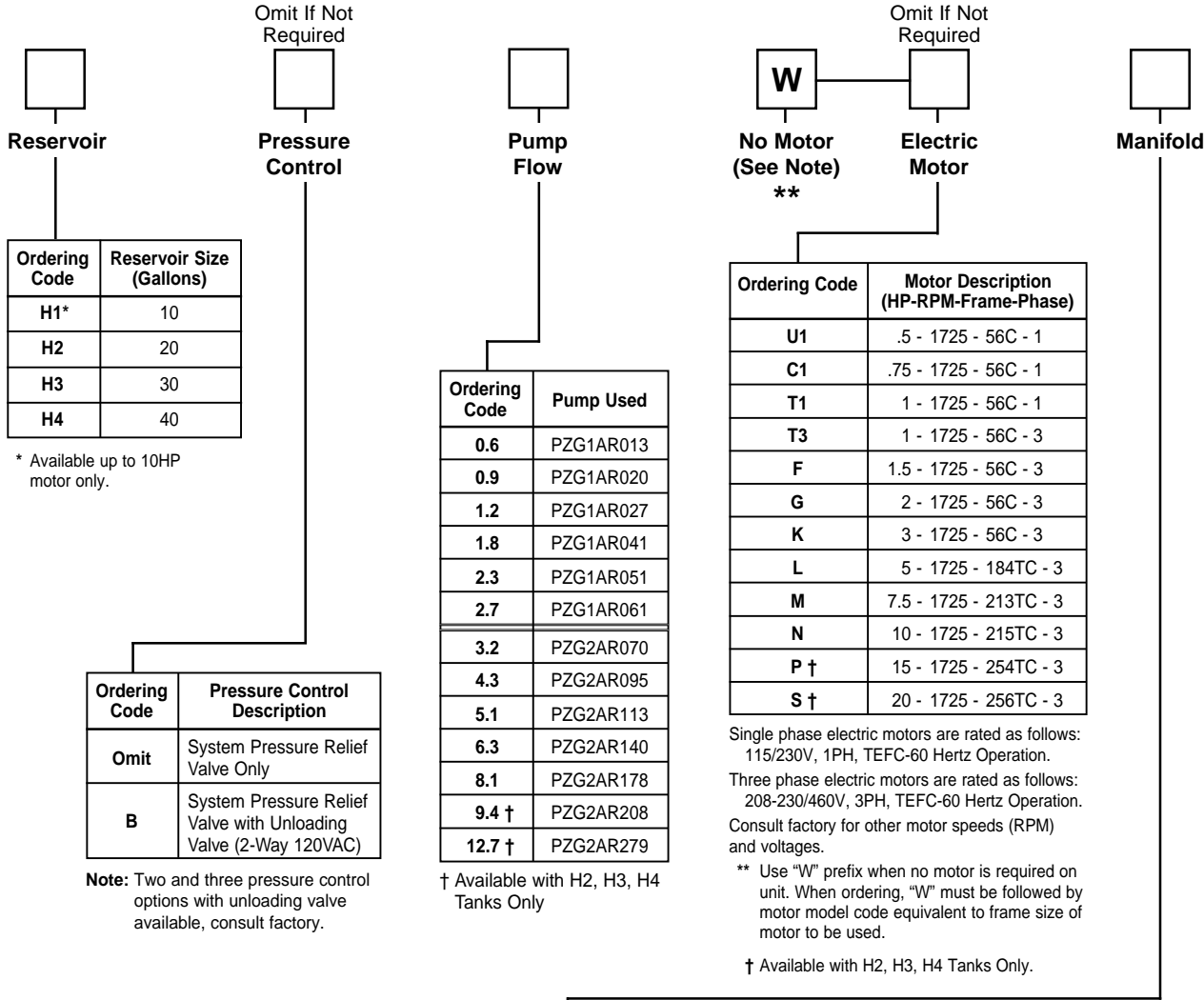

Ordering Code	Reservoir Size (Gallons)
H1*	10
H2	20
H3	30
H4	40

* Available up to 10HP motor only.

Ordering Code	Pressure Control Description
Omit	System Pressure Relief Valve Only
B	System Pressure Relief Valve with Unloading Valve (2-Way 120VAC)

Note: Two and three pressure control options with unloading valve available, consult factory.

Ordering Code	Pump Used
0.6	PZG1AR013
0.9	PZG1AR020
1.2	PZG1AR027
1.8	PZG1AR041
2.3	PZG1AR051
2.7	PZG1AR061
3.2	PZG2AR070
4.3	PZG2AR095
5.1	PZG2AR113
6.3	PZG2AR140
8.1	PZG2AR178
9.4 †	PZG2AR208
12.7 †	PZG2AR279

† Available with H2, H3, H4 Tanks Only

Ordering Code	Motor Description (HP-RPM-Frame-Phase)
U1	.5 - 1725 - 56C - 1
C1	.75 - 1725 - 56C - 1
T1	1 - 1725 - 56C - 1
T3	1 - 1725 - 56C - 3
F	1.5 - 1725 - 56C - 3
G	2 - 1725 - 56C - 3
K	3 - 1725 - 56C - 3
L	5 - 1725 - 184TC - 3
M	7.5 - 1725 - 213TC - 3
N	10 - 1725 - 215TC - 3
P †	15 - 1725 - 254TC - 3
S †	20 - 1725 - 256TC - 3

Single phase electric motors are rated as follows: 115/230V, 1PH, TEFC-60 Hertz Operation.
 Three phase electric motors are rated as follows: 208-230/460V, 3PH, TEFC-60 Hertz Operation.
 Consult factory for other motor speeds (RPM) and voltages.

** Use "W" prefix when no motor is required on unit. When ordering, "W" must be followed by motor model code equivalent to frame size of motor to be used.

† Available with H2, H3, H4 Tanks Only.

Ordering Code	Porting Block/Subplate or Manifold Type	Supply/Return Port Actuator Port Size	Other
O	Pressure and Return Port Block with Safety Relief Valve	"P" & "T" Ports SAE-12 Str. Thr'd	Convertible to S3, S5, S6 Option
S3	D03 Single Station Subplate with Safety Relief Valve	"A" & "B" Ports SAE-8 Str. Thr'd	Spare "P" & "T" SAE-10 Ports
S5	D05 Single Station Subplate with Safety Relief Valve	"A" & "B" Ports SAE-10 Str. Thr'd	Spare "P" & "T" SAE-12 Ports
S6	D05H/D05HE Single Station Subplate with Safety Relief Valve	"A" & "B" Ports SAE-10 Str. Thr'd	"X" & "Y" Ports SAE-4 (H & HE)
M3 *	D03 Multistation Parallel Circuit Manifold with Safety Relief Valve	"A" & "B" Ports SAE-8 Str. Thr'd	Spare "G" Port SAE-6
M5 *†	D05 Multistation Parallel Circuit Manifold with Safety Relief Valve	"A" & "B" Ports SAE-8 Str. Thr'd	Spare "G" Port SAE-6
M6 *†	D05H Multistation Parallel Circuit Manifold with Safety Relief Valve	"A" & "B" Ports SAE-12 Str. Thr'd	Spare "G" SAE-6 No "X" & "Y" Ports

* When ordering Multi-Station Manifolds, the number of stations must be specified. If more than 5 stations required, consult factory. If valves are to be mounted, specify the valves and sequence. If the model code exceeds 25 digits, utilize the special ordering code X.

Example: H2 6.3 N M53X
 X= 3 Station Manifold
 Station #1: E
 Station #2: F
 Station #3: G4

NOTE:
 Manifolds are mounted vertically.
 Bottom station is number 1.

† Available with H2, H3, H4 only.

Ordering Information

H-Paks

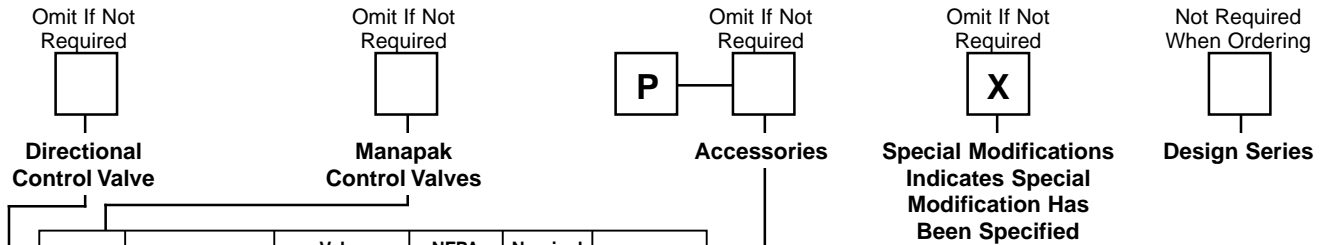

Ordering Code	Function	Valve Model Number	NFPA Mounting Pad	Nominal Flow (GPM)	Circuit Symbol
1	Flow Control	FM2DDKN	D03	7	
2	Flow Control	FM3DDKN	D05	12	
3	Pilot Operator Check	CPOM2DDN	D03	7	
4	Pilot Operator Check	CPOM3DDN	D05	12	
5	"P" Port Check	CM2PPN	D03	7	
6	"P" Port Check	CM3PPN	D05	12	
7	"P" Port Pressure Reducing	PRM2PP25KN (150-3000)	D03	6	
8	"P" Port Pressure Reducing	PRM3PA25KN (150-3000)	D05	12	

Ordering Code	Function	Model Number	Technical Data
B1*	Return Heat Exchanger	RM-08-1-2	Air/Oil: .7HP Rejection @ 7 GPM (1/2 - 5HP Motors Only)
B2*	Return Heat Exchanger	RM-190-1-2	Air/Oil: 1.5HP Rejection @ 7 GPM (7.5-15HP Motors Only)
C*	Return Heat Exchanger	N401A40	Oil/Water (1:1): 5HP Rej. @ 7 GPM (9 GPM Max.) (9 PSI Diff. @ 7 GPM)
D*	Return Heat Exchanger	N701B6F	Oil/Water (2:1): 4HP Rej. @ 7 GPM (25 GPM Max.) (3 PSI Diff. @ 7 GPM)
E	Water Temp. Modulating Valve	V47AC-6	75°F to 135°F Adj. Range Cross Ambient Sensing 3/4" NPT Inlet
H	Pressure Filter	15P110BXRS	Microglass Element Vis. Ind. - 50 PSI Bypass (4 PSI Diff. @ 7 GPM)
J	Immersion Heater	BGS79J6-W1	1 KW, 120/240 V, 1PH, 30-110°F Thermostat NEMA 4 (23 W/Sq.In.)
K	Check Valve Pump Outlet	"DT" & "C" Series	5 PSI Cracking Pressure (25 PSI Diff. @ 15 GPM)
L	Bypass Check (On Heat Exch.)	C1220S65	65 PSI Cracking Pressure
M	Return Filter	15CN110B	Microglass Element Visual 25 PSI Indicator (5 PSI Diff. @ 7 GPM)
N	Return Filter	40CN110B	Microglass Element Visual 25 PSI Indicator (3 PSI Diff. @ 7 GPM)
O	Return Filter	12AT10C	Cellulose Element Ind. Gage - 15 PSI Bypass (12 GPM Max. Oil Flow)
R1	Combination Float/Temp. SW N.O. Float Up	876361-*	Fixed Temp at 149°F Close @ Low Level And/Or 149°F (N.O.)
R2	Combination Float/Temp. SW N.O. Float Up	876360-*	Fixed Temp at 150°F Open @ Low Level And/Or 150°F (N.C.)
V	Return Filter	50AT10C	Cellulose Element Ind. Gage - 15 PSI Bypass (35 GPM Max. Oil Flow)
W1	Pressure Switch 90-700 PSI	PDP34FCHC	N.O. & N.C. Contacts (SPDT Switch) DIN 43650 Connector 5A @ 125/250VAC Induct 7A @ 12/25VDC Induct
W2	Pressure Switch 700-3000 PSI	PDP54FCHC	
Z	Temperature Switch	837-A4A NEMA 1	60°F-190°F Adjust. Differential N.O. & N.C. Contacts

Ordering Code	Valve Model Number	NFPA Mounting Pad	Nominal Flow (GPM)	Solenoid Operator -110 VAC	Circuit Symbol
A	D1VW20BNCYCF	D03	7	Single (Spr. Ret)	
B	D1VW1CNCYCF	D03	7	Double (Spr. Ctr)	
C	D1VW4CNCYCF	D03	7	Double (Spr. Ctr)	
D	D1VW20DNCYCF	D03	7	Double (Detent)	
E	D3W1BNCYCF	D05	12	Single (Spr. Ret)	
F	D3W1CNCYCF	D05	12	Double (Spr. Ctr)	
G	D3W4CNCYCF	D05	12	Double (Spr. Ctr)	
H	D3W1DNCYCF	D05	12	Double (Detent)	
J	D31VW20B4NCYCF	D05H	20	Single (Spr. Ret)	
K	D31VW1C4NCYCF	D05H	20	Double (Spr. Ctr)	
L	D31VW4C4NCYCF	D05H	20	Double (Spr. Ctr)	
M	D31VW20D4NCYCF	D05H	20	Double (Detent)	
N	Cover Plate	D03	-	-	
R	Cover Plate	D05	-	-	
S	D1VW2CNCYCF	D03	7	Double (Spr. Ctr)	
T	D1VW8CNCYCF	D03	7	Double (Spr. Ctr)	
V	D3W2CNCYCF	D05	12	Double (Spr. Ctr)	
W	D3W8CNCYCF	D05	12	Double (Spr. Ctr)	

* Heat rejection based on flow given with a 40°F differential between transfer medium.

Ordering Information

V-Paks – 2 thru 7 GPM

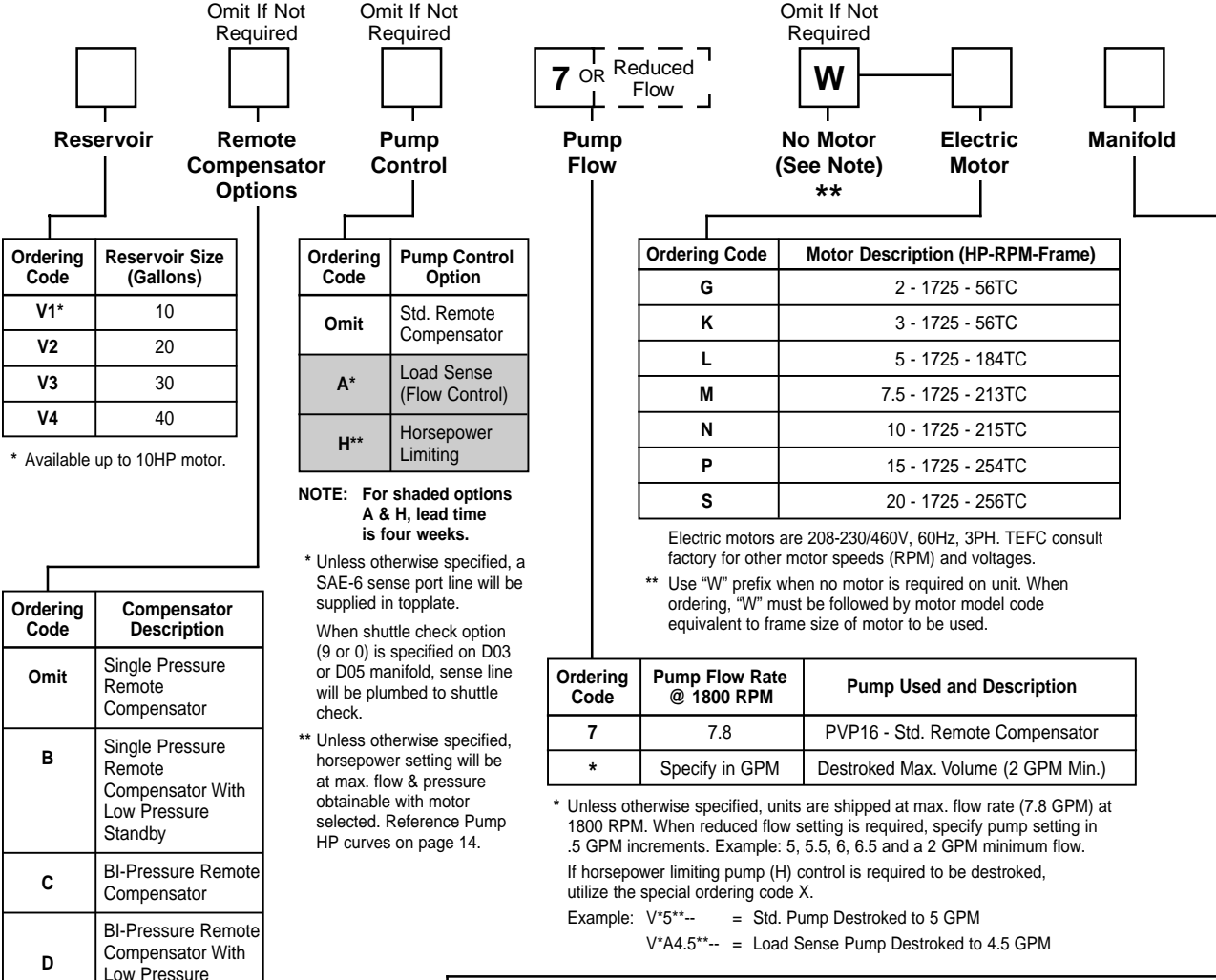

Ordering Code	Pump Control/Mounting	Supply/Return Port Actuator Port Size	Other
O	Pressure and Return Port Block with Safety Relief Valve	"P" & "T" Port SAE-12 Str. Thr'd	Convertible to S3, S5, S6 Option
S3	D03 Single Station Subplate with Safety Relief Valve	"A" & "B" Ports SAE-8 Str. Thr'd	Spare "P" & "T" SAE-10 Ports
S5	D05 Single Station Subplate with Safety Relief Valve	"A" & "B" Ports SAE-10 Str. Thr'd	Spare "P" & "T" SAE-12 Ports
S6	D05H/D05HE Single Station Subplate with Safety Relief Valve	"A" & "B" Ports SAE-10 Str. Thr'd	"X" & "Y" Ports SAE-4 (H & HE)
M3 *	D03 Multistation Parallel Circuit Manifold with Safety Relief Valve	"A" & "B" Ports SAE-8 Str. Thr'd	Spare "G" Port SAE-6
M5 *	D05 Multistation Parallel Circuit Manifold with Safety Relief Valve	"A" & "B" Ports SAE-8 Str. Thr'd	Spare "G" Port SAE-6
M6 *†	D05H Multistation Parallel Circuit Manifold with Safety Relief Valve	"A" & "B" Ports SAE-12 Str. Thr'd	Spare "G" SAE-6 No "X" & "Y" Ports

* When ordering Multi-Station Manifolds, the number of stations must be specified. If more than 5 stations required, consult factory. If valves are to be mounted, specify the valves and sequence. If the model code exceeds 25 digits, utilize the special ordering code X.
 Example: V2 7 N M33X
 X= 3 Station Manifold
 Station #1: A
 Station #2: B
 Station #3: C24

NOTE: Manifolds are mounted vertically. Bottom station is number 1.

† Available with V2, V3, V4 only.

Ordering Information

V-Paks – 2 thru 7 GPM

Omit If Not Required



Directional Control Valve

Omit If Not Required



Manapak Control Valves

Omit If Not Required



Accessories

Omit If Not Required



Special Modifications Indicates Special Modification Has Been Specified

Not Required When Ordering



Design Series

Ordering Code	Function	Valve Model Number	NFPA Mounting Pad	Nominal Flow (GPM)	Circuit Symbol
1	Flow Control	FM2DDKN	D03	7	
2	Flow Control	FM3DDKN	D05	12	
3	Pilot Operator Check	CPOM2DDN	D03	7	
4	Pilot Operator Check	CPOM3DDN	D05	12	
5	"P" Port Check	CM2PPN	D03	7	
6	"P" Port Check	CM3PPN	D05	12	
7	"P" Port Pressure Reducing	PRM3PAH (150-3500)	D03	6	
8	"P" Port Pressure Reducing	PRM6PAH (150-3000)	D05	12	
9*	Shuttle Check (Load Sense)	-	D03	-	
0*	Shuttle Check (Load Sense)	-	D05	-	

* Use in combination with load sense pump type (7A) and flow control valve option (1 or 3).

Ordering Code	Valve Model Number	NFPA Mounting Pad	Nominal Flow (GPM)	Solenoid Operator -110 VAC	Circuit Symbol
A	D1VW20BNYCF	D03	7	Single (Spr. Ret)	
B	D1VW1CNYCF	D03	7	Double (Spr. Ctr)	
C	D1VW4CNYCF	D03	7	Double (Spr. Ctr)	
D	D1VW20DNYCF	D03	7	Double (Detent)	
E	D3W1BNYCF	D05	12	Single (Spr. Ret)	
F	D3W1CNYCF	D05	12	Double (Spr. Ctr)	
G	D3W4CNYCF	D05	12	Double (Spr. Ctr)	
H	D3W1DNYCF	D05	12	Double (Detent)	
N	Cover Plate	D03	-	-	
R	Cover Plate	D05	-	-	

Ordering Code	Function	Model Number	Technical Data
A*	Pump Case Heat Exchanger	RM-08-4-2	Air/Oil: .7HP Rejection @ .5 GPM (2-15HP Motors)
B1*	Return Heat Exchanger	RM-08-1-2	Air/Oil: .7HP Rejection @ 7 GPM (2-5HP Motors Only)
B2*	Return Heat Exchanger	RM-190-1-2	Air/Oil: 1.5HP Rejection @ 7 GPM (7.5-15HP Motors Only)
C*	Return Heat Exchanger	N401A40	Oil/Water (1:1): 5HP Rej. @ 7 GPM (9 GPM Max.) (9 PSI Diff. @ 7 GPM)
D*	Return Heat Exchanger	N701B6F	Oil/Water (2:1): 4HP Rej. @ 7 GPM (25 GPM Max.) (3 PSI Diff. @ 7 GPM)
E	Water Temp. Modulating Valve	V47AC-6	75°F to 135°F Adj. Range Cross Ambient Sensing 3/4" NPT Inlet
H	Pressure Filter	15P110BXRS	Microglass Element Vis. Ind. - 50 PSI Bypass (4 PSI Diff. @ 7 GPM)
J	Immersion Heater	BGS79J6-W1	1 KW, 120/240 V, 1PH, 30-110°F Thermostat NEMA 4 (23 W/Sq.In.)
K	Check Valve Pump Outlet	DT750MOMF05	5 PSI Cracking Pressure (8 PSI Diff. @ 7 GPM)
L	Bypass Check (On Heat Exch.)	C1220S65	65 PSI Cracking Pressure
M	Return Filter	15CN110B	Microglass Element Visual 25 PSI Indicator (5 PSI Diff. @ 7 GPM)
N	Return Filter	40CN110B	Microglass Element Visual 25 PSI Indicator (3 PSI Diff. @ 7 GPM)
O	Return Filter	12AT10C	Cellulose Element Ind. Gage - 15 PSI Bypass (12 GPM Max. Oil Flow)
R1	Combination Float/Temp. SW N.O. Float Up	876361-*	Fixed Temp at 149°F Close @ Low Level And/Or 149°F (N.O.)
R2	Combination Float/Temp. SW N.O. Float Up	876360-*	Fixed Temp at 150°F Open @ Low Level And/Or 150°F (N.C.)
V	Return Filter	50AT10C	Cellulose Element Ind. Gage - 15 PSI Bypass (35 GPM Max. Oil Flow)
W1	Pressure Switch 90-700 PSI	PDP34FCHC	N.O. & N.C. Contacts (SPDT Switch) DIN 43650 Connector 5A @ 125/250VAC Induct 7A @ 12/25VDC Induct
W2	Pressure Switch 700-3000 PSI	PDP54FCHC	N.O. & N.C. Contacts (SPDT Switch) DIN 43650 Connector 5A @ 125/250VAC Induct 7A @ 12/25VDC Induct
Z	Temperature Switch	837-A4A NEMA 1	60°F-190°F Adjust. Differential N.O. & N.C. Contacts

* Heat rejection based on flow given with a 40°F differential between transfer medium.

Ordering Information

V-Paks – 8 thru 15 GPM

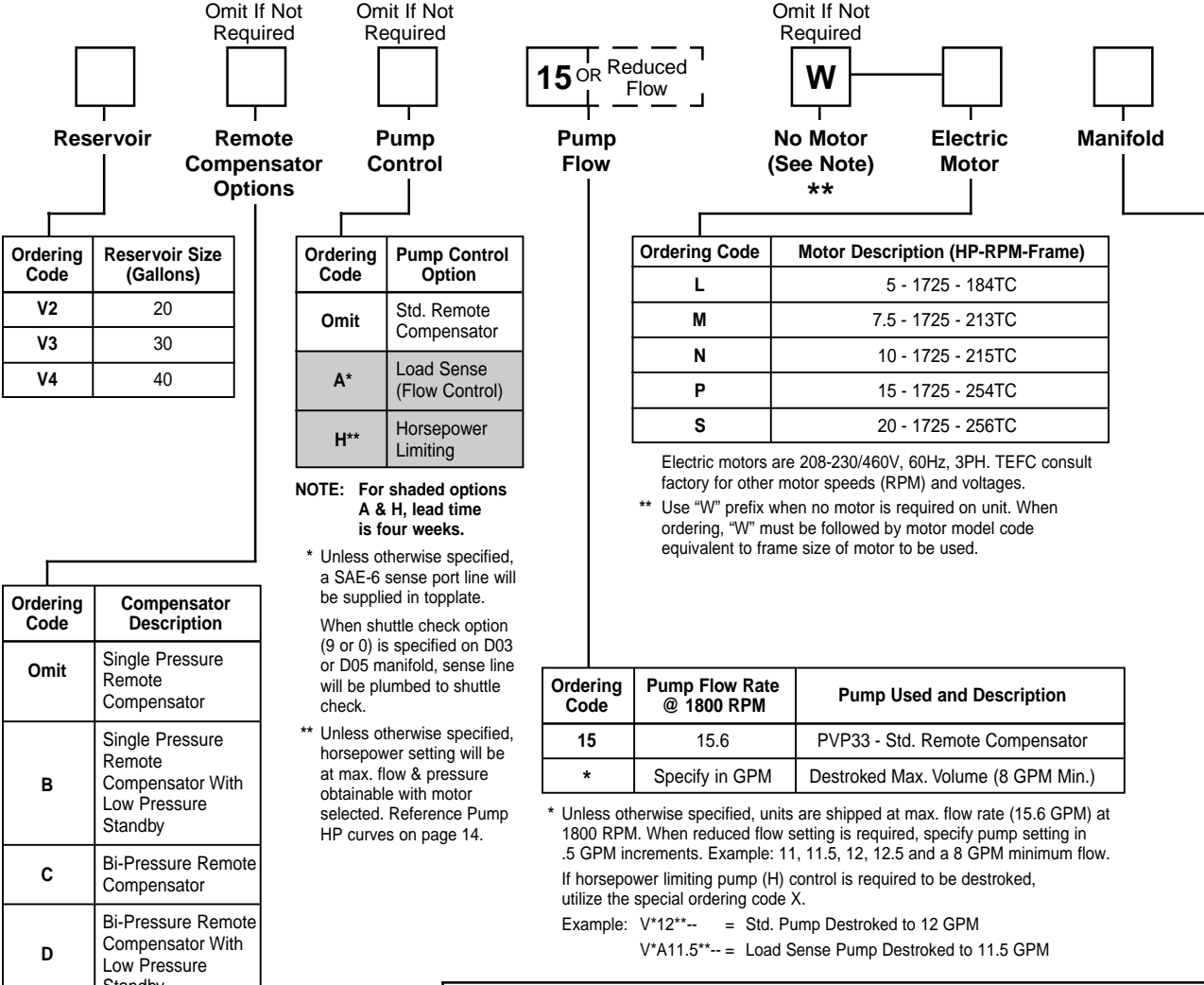

NOTE: For shaded options A & H, lead time is four weeks.

* Unless otherwise specified, a SAE-6 sense port line will be supplied in toplate.

When shuttle check option (9 or 0) is specified on D03 or D05 manifold, sense line will be plumbed to shuttle check.

** Unless otherwise specified, horsepower setting will be at max. flow & pressure obtainable with motor selected. Reference Pump HP curves on page 14.

Electric motors are 208-230/460V, 60Hz, 3PH. TEFC consult factory for other motor speeds (RPM) and voltages.

** Use "W" prefix when no motor is required on unit. When ordering, "W" must be followed by motor model code equivalent to frame size of motor to be used.

Ordering Code	Pump Flow Rate @ 1800 RPM	Pump Used and Description
15	15.6	PVP33 - Std. Remote Compensator
*	Specify in GPM	Destroyed Max. Volume (8 GPM Min.)

* Unless otherwise specified, units are shipped at max. flow rate (15.6 GPM) at 1800 RPM. When reduced flow setting is required, specify pump setting in .5 GPM increments. Example: 11, 11.5, 12, 12.5 and a 8 GPM minimum flow. If horsepower limiting pump (H) control is required to be destroyed, utilize the special ordering code X.

Example: V*12**-- = Std. Pump Destroyed to 12 GPM
 V*A11.5**-- = Load Sense Pump Destroyed to 11.5 GPM

* Consult factory for driver card options.

Ordering Code	Porting Block/Subplate or Manifold Type	Supply/Return Port or Actuator Port Size	Other
O	Pressure and Return Port Block with Safety Relief Valve	"P" & "T" Ports SAE-12 Str. Thr'd	Convertible to S3, S5, S6 Option
S3	D03 Single Station Subplate with Safety Relief Valve	"A" & "B" Ports SAE-8 Str. Thr'd	Spare "P" & "T" SAE-10 Ports
S5	D05 Single Station Subplate with Safety Relief Valve	"A" & "B" Ports SAE-10 Str. Thr'd	Spare "P" & "T" SAE-12 Ports
S6	D05H/D05HE Single Station Subplate with Safety Relief Valve	"A" & "B" Ports SAE-10 Str. Thr'd	"X" & "Y" Ports SAE-4 (H & HE)
M3*	D03 Multistation Parallel Circuit Manifold with Safety Relief Valve	"A" & "B" Ports SAE-8 Str. Thr'd	Spare "G" Port SAE-6
M5*	D05 Multistation Parallel Circuit Manifold with Safety Relief Valve	"A" & "B" Ports SAE-8 Str. Thr'd	Spare "G" Port SAE-6
M6*	D05H Multistation Parallel Circuit Manifold with Safety Relief Valve	"A" & "B" Ports SAE-12 Str. Thr'd	Spare "G" SAE-6 No "X" & "Y" Ports

* When ordering Multi-Station Manifolds, the number of stations must be specified. If more than 5 stations required, consult factory. If valves are to be mounted, specify the valves and sequence. If the model code exceeds 25 digits, utilize the special ordering code X.

Example: V3 11 N M53X
 X= 3 Station Manifold
 Station #1: E
 Station #2: F
 Station #3: G4

NOTE:
 Manifolds are mounted vertically.
 Bottom station is number 1.

Ordering Information

V-Paks – 8 thru 15 GPM

Omit If Not Required



Directional Control Valve

Omit If Not Required



Manapak Control Valves

Omit If Not Required



Accessories

Omit If Not Required



Special Modifications Indicates Special Modification Has Been Specified

Not Required When Ordering



Design Series

Ordering Code	Function	Valve Model Number	NFPA Mounting Pad	Nominal Flow (GPM)	Circuit Symbol
1	Flow Control	FM2DDKN	D03	7	
2	Flow Control	FM3DDKN	D05	12	
3	Pilot Operator Check	CPOM2DDN	D03	7	
4	Pilot Operator Check	CPOM3DDN	D05	12	
5	"P" Port Check	CM2PPN	D03	7	
6	"P" Port Check	CM3PPN	D05	12	
7	"P" Port Pressure Reducing	PRM2PP25KN (150-3500)	D03	6	
8	"P" Port Pressure Reducing	PRM3PA25KN (150-3000)	D05	12	
9*	Shuttle Check (Load Sense)	-	D03	-	
0*	Shuttle Check (Load Sense)	-	D05	-	

* Use in combination with load sense pump type (A15) and flow control valve option (1 or 3).

Ordering Code	Function	Model Number	Technical Data
A*	Pump Case Heat Exchanger	RM-08-4-2	Air/Oil: .7HP Rejection @ .5 GPM (2-20HP Motors)
B1*	Return Heat Exchanger	RM-08-1-2	Air/Oil: .7HP Rejection @ 15 GPM (2-5HP Motors Only)
B2*	Return Heat Exchanger	RM-190-1-2	Air/Oil: 1.7HP Rejection @ 15 GPM (7.5-20HP Motors Only)
D*	Return Heat Exchanger	N701B6F	Oil/Water (2:1): 6.5HP Rej. @ 15 GPM (25 GPM Max.) (3 PSI Diff. @ 15 GPM)
E	Water Temp. Modulating Valve	V47AC-6	75°F to 135°F Adj. Range Cross Ambient Sensing 3/4" NPT Inlet
H	Pressure Filter	15P110BXR	Microglass Element Vis. Ind. - 50 PSI Bypass (12 PSI Diff. @ 15 GPM)
J	Immersion Heater	BGS79J6-W1	1 KW, 120/240 V, 1PH, 30-110°F Thermostat NEMA 4 (23 W/Sq.In.)
K	Check Valve Pump Outlet	DT750MOMF05	5 PSI Cracking Pressure (25 PSI Diff. @ 15 GPM)
L	Bypass Check (on Heat Exch.)	C1220S65	65 PSI Cracking Pressure
M	Return Filter	15CN110B	Microglass Element Visual 25 PSI Indicator (9 PSI Diff. @ 15 GPM)
N	Return Filter	40CN110B	Microglass Element Visual 25 PSI Indicator (5 PSI Diff. @ 15 GPM)
O	Return Filter	12AT10C	Cellulose Element Ind. Gage - 15 PSI Bypass (12 GPM Max. Oil Flow)
R1	Combination Float/Temp. SW N.O. Float Up	876361-*	Fixed Temp at 149°F Close @ Low Level And/Or 149°F (N.O.)
R2	Combination Float/Temp. SW N.C. Float Up	876360-*	Fixed Temp at 150°F Open @ Low Level And/Or 150°F (N.C.)
V	Return Filter	50AT10C	Cellulose Element Ind. Gage - 15 PSI Bypass (35 GPM Max. Oil Flow)
W1	Pressure Switch 90-700 PSI	PDP34FCHC	N.O. & N.C. Contacts (SPDT Switch) DIN 43650 Connector 5A @ 125/250VAC Induct 7A @ 12/25VDC Induct
W2	Pressure Switch 700-3000 PSI	PDP54FCHC	
Z	Temperature Switch	837-A4A NEMA 1	60°F-190°F Adjust. Differential N.O. & N.C. Contacts

* Heat rejection based on flow given with a 40°F differential between transfer medium.

Ordering Code	Valve Model Number	NFPA Mounting Pad	Nominal Flow (GPM)	Solenoid Operator -110 VAC	Circuit Symbol
A	D1VW20BNYCF	D03	7	Single (Spr. Ret)	
B	D1VW1CNYCF	D03	7	Double (Spr. Ctr)	
C	D1VW4CNYCF	D03	7	Double (Spr. Ctr)	
D	D1VW20DNYCF	D03	7	Double (Detent)	
E	D3W1BNYCF	D05	12	Single (Spr. Ret)	
F	D3W1CNYCF	D05	12	Double (Spr. Ctr)	
G	D3W4CNYCF	D05	12	Double (Spr. Ctr)	
H	D3W1DNYCF	D05	12	Double (Detent)	
J	D31VW20B4NYCF	D05H	20	Single (Spr. Ret)	
K	D31VW1C4NYCF	D05H	20	Double (Spr. Ctr)	
L	D31VW4C4NYCF	D05H	20	Double (Spr. Ctr)	
M	D31VW20D4NYCF	D05H	20	Double (Detent)	
N	Cover Plate	D03	-	-	
R	Cover Plate	D05	-	-	



Operating Notes

- Jog the electric motor once and verify that the electric motor is rotating in the same direction as the arrow on the electric motor housing. If direction is incorrect, reverse two of the three leads on a 3-phase electric motor.
- D & H-Pak power units are tested and relief valve is set at maximum pressure of the pump/motor combination.
- V-Pak power units are tested and pressure control valves are factory preset. If adjustments are needed, follow the procedure below: Begin adjusting relief valve and pump compensator control valve to increase pressure gradually. (**NOTE:** Always set relief valve 250 PSI higher than pump compensator pressure control valve or severe overheating will occur.)
- If pump fails to prime, vent pump discharge to atmosphere to establish fluid flow.
- Reservoir temperature should not exceed 150°F. System reliability and component service life will be reduced when system is operated at higher temperature.
- Clean fluid = improved system reliability and longer component service life, change filter elements whenever filter indicators indicate a dirty element condition.

- It is recommended that every 4,000 operating hours or once a year, whichever occurs first, the filler/breather cap and suction strainer should be replaced.

Fluid Recommendations

Premium quality hydraulic oil with a viscosity range between 150-250 SSU (30-50 cst.) at 100°F (38°C). Normal operating viscosity range between 80-1000 SSU (17-180 cst.). Maximum start-up viscosity is 4000 SSU (1000 cst.).

NOTE: Consult Parker when exceeding 160°F (71°C) operation. Oil should have maximum anti-wear properties, rust and oxidation treatment.

Filtration

For maximum pump and system component life, the system should be protected from contamination at a level not to exceed 125 particles greater than 10 microns per milliliter of fluid. (SAE Class 4 / ISO 16/13.) Due to the nature of variable displacement pumps, variations in pump inlet conditions, fluid acceleration losses, system aeration, and duty cycle must be carefully considered before specifying suction line filtration. Contact your Parker representative for assistance.

NOTE: For additional information refer to Bulletin No. IG2600-550/NA.

Pump Mounting Adapters

Technical Information

The totally enclosed pump mounting bracket offers precision shaft alignment and safety from the rotating shafts and coupling. The bracket is designed to mount on the motor face with the motor coupling half secure to the shaft. Then the pump, with its coupling half secure on the pump shaft, is mounted and the coupling halves are engaged. This will require proper spacing of the coupling prior to installation and a coupling with an outside diameter less than "P" dimension. If the coupling selected cannot be assembled this way, both coupling halves must be installed on the motor shaft. Next, mount the adapter on the motor. Then the pump can be mounted and the coupling secured to the pump by using the access slot to tighten the pump shaft coupling set screw.



Dimensions*

Pump Mounting Adapter

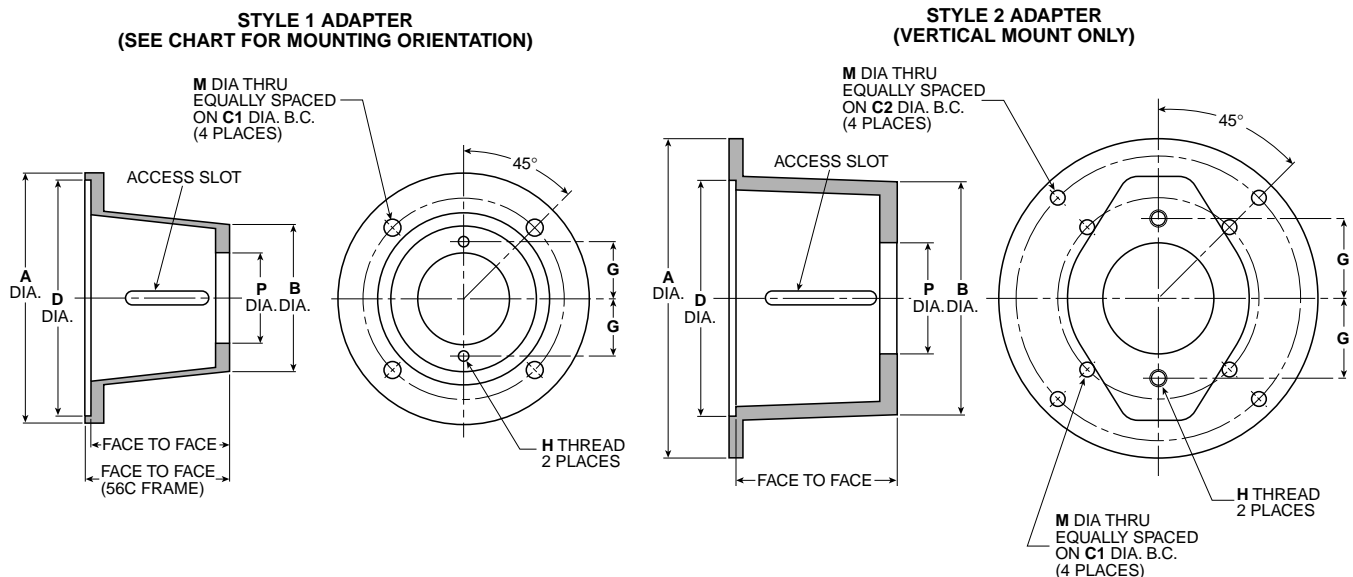

Model Number	Pump Mounting	Motor Mounting	A	B	C1	C2	D	Face to Face	G	H	M	P	Vertical Mounting	Horizontal Mounting	Style	Weight
876631	SAE AA	56C	6.7	5.0	5.88	N/A	4.50	3.50	1.63	3/8-16	0.44	2.00	YES	YES	1	3 lb.
876632	SAE AA	182TC/256TC	9.0	5.3	7.25	N/A	8.50	5.00	1.63	3/8-16	0.56	2.00	YES	YES	1	4 lb.
876633	SAE A	56C	6.7	5.0	5.88	N/A	4.50	4.25	2.10	3/8-16	0.44	3.25	YES	YES	1	4 lb.
876634	SAE A	182TC/256TC	9.0	5.3	7.25	N/A	8.50	5.00	2.10	3/8-16	0.56	3.25	YES	YES	1	4 lb.
876635	SAE A	182TC/256TC	9.0	5.3	7.25	N/A	8.50	5.88	2.10	3/8-16	0.56	3.25	YES	YES	1	5 lb.
875343	SAE B	182TC/256TC	11.4	9.0	7.25	10.25	8.50	5.75	2.88	1/2-13	0.53	4.00	YES	NO	2	7 lb.
875344	SAE B	182TC/256TC	11.4	9.0	7.25	10.25	8.50	6.81	2.88	1/2-13	0.53	4.00	YES	NO	2	8 lb.
876683	SAE B	182TC/256TC	9.0	8.8	7.25	N/A	8.50	6.38	2.88	1/2-13	0.53	4.00	NO	YES	1	7 lb.
876684	SAE C	182TC/256TC	9.0	9.3	7.25	N/A	8.50	6.69	3.56	5/8-11	0.53	5.00	NO	YES	1	20 lb.

* All dimensions are in inches.

NOTE: It is the responsibility of the user to check the listed dimensions to ensure suitability of mounting adapter with pump/coupling/motor combination.

Offer of Sale

Application Formulas

- 1 GPM at 1500 PSI = 1 HP (General Rule)
- 1 Gallon = 231 Cubic Inches (3.7854 Liters)
- 1 Gallon Oil = 7.08 Lbs.
- 1 bar = 14.5 PSI
- 25.4mm = 1 Inch
- 1 HP = 42.4 BTU/Min.
- 1 Gallon = 3.7854 Liters

$$\text{HP} = \frac{\text{GPM} \times \text{PSI}}{1714 \times \text{Pump Efficiency}}$$

$$\text{PSI} = \frac{1714 \times \text{Pump Efficiency} \times \text{HP}}{\text{GPM}}$$

$$\text{GPM} = \frac{1714 \times \text{Pump Efficiency} \times \text{HP}}{\text{PSI}}$$

$$\text{HP} = \frac{\text{Torque (in.-lbs.)} \times \text{RPM}}{63025}$$

$$\text{Torque} = \frac{\text{HP} \times 63025}{\text{RPM}}$$

$$\text{RPM} = \frac{\text{HP} \times 63025}{\text{Torque}}$$

Motor Information

At 440V — 3-Phase Motor Draws 1.25 AMP/HP

At 220V — 3-Phase Motor Draws 2.5 AMP/HP

At 110V — Single Phase Motor Draws 10 AMP/HP