

Accessories

Adapter kits and accessories for F1, F2, T1 and VP1 pumps

Contents

PTO Air valve kits:

- Volvo PTO's
- Scania PTO's
- Universal

PTO adapter kits:

- for Scania ED 90 engines
- for Scania ED 120 engines
- for Scania ED 140 engines
- for Scania ED 160 engines
- for Mercedes engines (Actros)
- ES, line mounted unloading valves

Cardan shafts, pump couplings and mounting brackets

Pump couplings

Return filter and filter indicator

Air breather filter

Check valves

SB splitter boxes

Air valve kit for Volvo PTO's

- The air valve kit is suitable for operating a Volvo PTO on Series FM and FH truck chassis (FH introduced Nov. -98). All parts required to operate the PTO are included in the kit (as shown below).
- The air valve can be combined with other air valves on the chassis; this means a simple installation with a common air supply and a minimum of hoses.
- All electrical wires are pre-installed on the chassis. The relay should be installed in socket K1-14 behind the dashboard cover.
- Function:
 The relay makes sure the PTO is being disengaged as soon as the 'ignition key' is turned off.
 To re-engage the PTO, the operator has to put the switch back to neutral, and then move it to the 'ON' position.



Air valve kit for Volvo PTO's.

PTO air valve kit	Volvo
Air valve nominal voltage [VDC]	24
Nominal current [A]	0.4
Required power [W]	9.6
Max air pressure [bar]	10
Air hose size	1/4"
Operating mode	Activated solenoid: Air valve open and PTO engaged.
Ordering number, series FM and FH ¹⁾	378 1010

1) Series FH(c) introduced Nov. -98.

Air valve kit for Scania PTO's

- All parts required for operating a Scania PTO are included in the kit (shown below).
- The air valve kit is suitable for all Scania chassis, Scania Original PTO's, and PTO's from Parker Hannifin for Scania chassis.
- The air valve can be combined with other air valves on the chassis; this means a simple installation with a common air supply and a minimum of hoses.
- All electrical wires are pre-installed on the chassis.

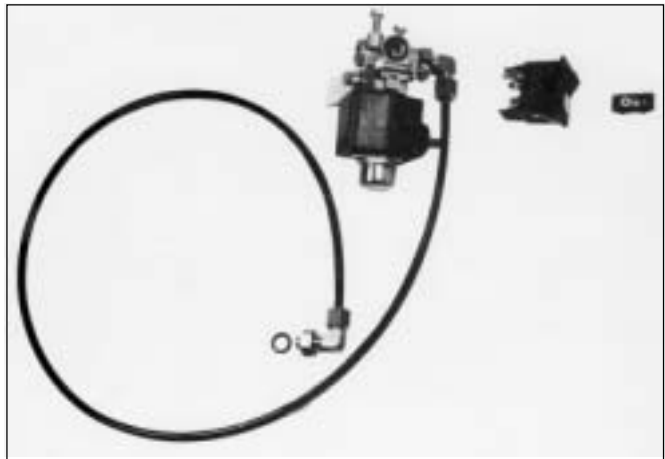

Air valve kit for Scania PTO's.

PTO air valve kit	Scania
Air valve nominal voltage [VDC]	24
Nominal current [A]	0.4
Required power [W]	9.6
Max air pressure [bar]	10
Air hose size	1/4"
Operating mode	Activated solenoid: Air valve open and PTO engaged.
Ordering number	370 5215

Universal PTO air valve kit

- The kit includes all parts required for maneuvering the PTO.
- The air valve kit is suitable for most PTO's with a metric M12x1.5 air connection.
- The air valve can be installed with other air valves on the chassis which means simple installation with common air supply and a minimum of hoses.
- The air valve can be connected to electrical wires usually pre-installed on the chassis.

PTO air valve kit	Universal
Air valve nominal voltage [VDC]	24
Nominal current [A]	0.4
Required power [W]	9.6
Max air pressure [bar]	10
Air hose size	1/4"
Operating mode	Activated solenoid: Air valve open and PTO engaged.
Ordering number	370 8779

PTO adapter kit for Scania ED 90 engines

- With the adapter kit, an hydraulic pump that meets the ISO standard can be installed on PTO of the Scania 9 liter engine DS/DSC 9.
- The PTO must be ordered with the chassis from Scania.
- For additional information please refer to Scania Service Information 19-86 03 30 GT SV.

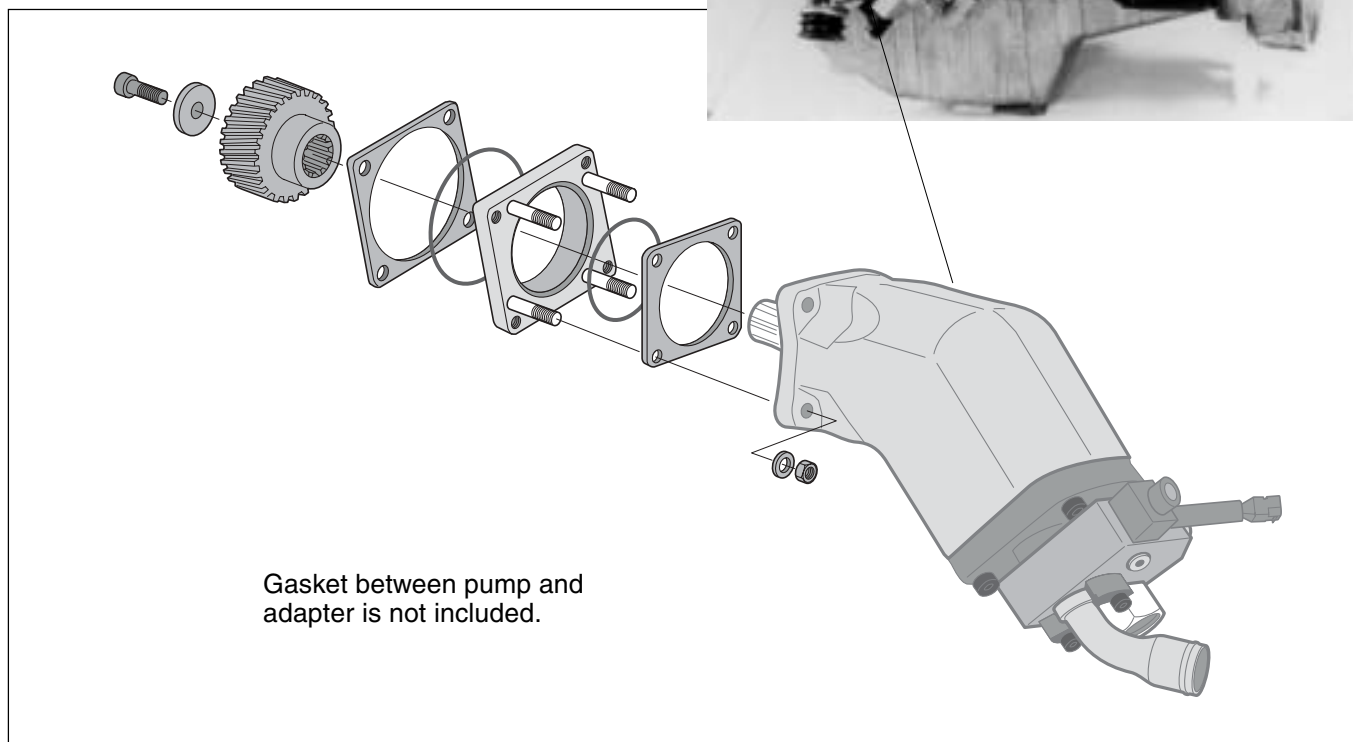
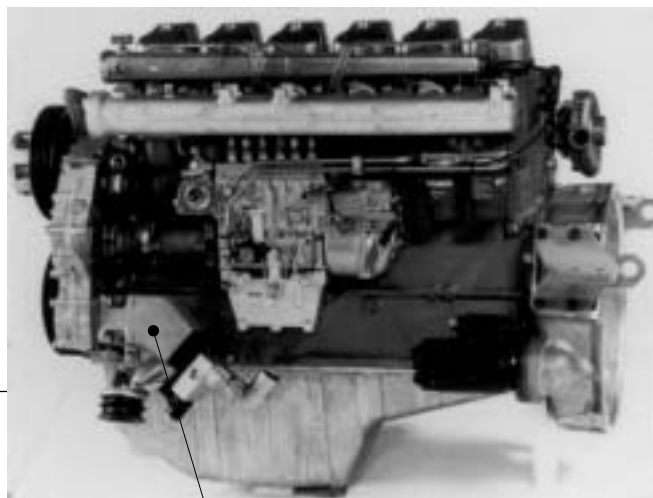

Pump size	F1-25	F1-41	F1-51	F1-61	F1-81	F1-101	F2-53/53	F2-70/35
Max. operating pressure [bar]	350	350	350	350	223	235	220	220
Bypass valve	Required							

NOTE: Max operating pressures shown for the F2 frame sizes are valid when both ports are pressurized to the same level simultaneously.

Max. torque [Nm]	360
Gear ratio (engine:pump)	1 : 0.975
Pump rotation	Right hand (clockwise)

PTO adapter kit	Ordering number
Scania ED-90	379 1729

PTO adapter kit for Scania ED 120 engines

- With the adapter kit, an hydraulic pump (e.g. F1 or VP1) that meets the ISO standard can be installed on the PTO of the Scania 12 liter engine.
- The PTO gear is supplied with the chassis.
- **Please note:** The engine must be ordered with a PTO.

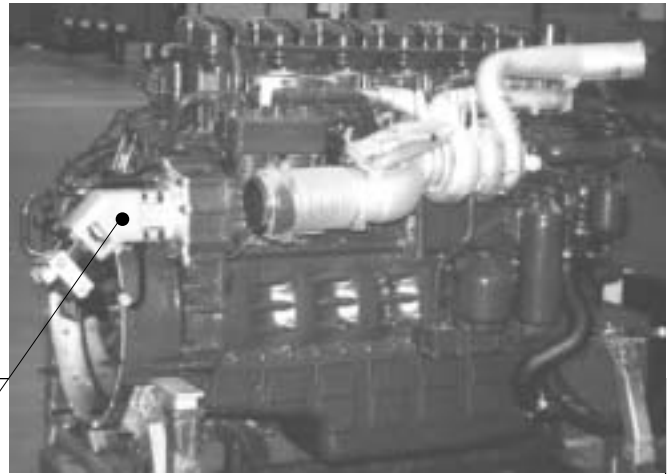

NOTE!
 When used on ED-120 the pump shall be mounted with the connections pointing "up".
 (note necessary when the gear in the PTO has a supportbearing)

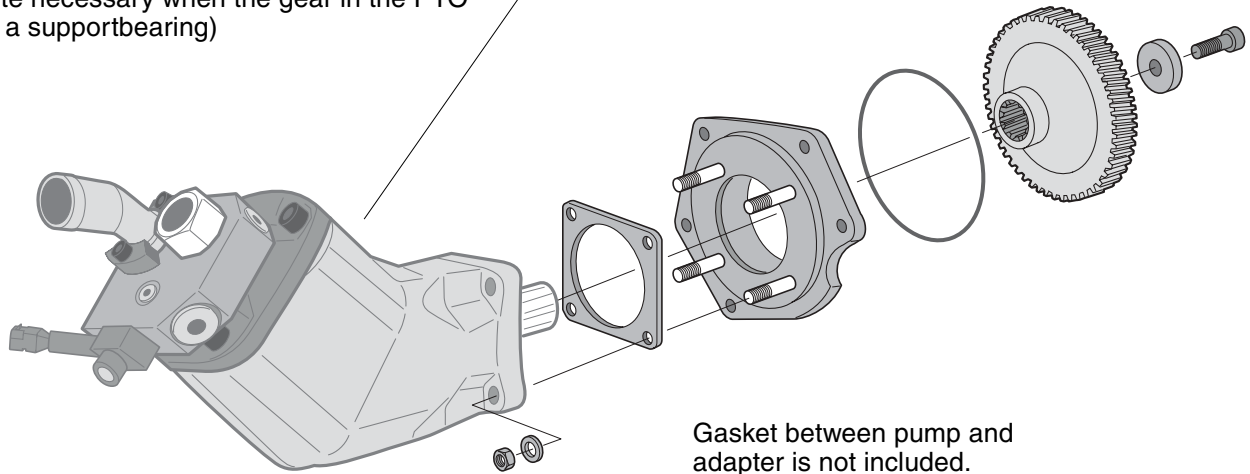

Pump size	F1-25	F1-41	F1-51	F1-61	F1-81	F1-101	F2-53/53	F2-70/35
Max. operating pressure [bar]	350			350			350	350
Bypass valve	Required							

NOTE: Max operating pressures shown for the F2 frame sizes are valid when both ports are pressurized to the same level simultaneously.

Max. torque [Nm]	600
Gear ratio (engine : pump)	1 : 1.19
Pump rotation	Right hand (clockwise)

PTO adapter kit	Ordering number*
ED-120-F1	378 2021
ED-120-VP1	378 2022

* Part numbers valid from 00-10-23 (W0043); replacing 379 9888 and 379 9889 respectively.

PTO adapter kit for Scania ED 140 engines

- With the adapter kit, an hydraulic pump that meets the ISO standard can be installed on PTO of the Scania 14 liter engine DS 14.
- The PTO gear is not supplied with the kit; it must be ordered separately. For model 144 and later it can be ordered either from Parker Hannifin, ordering number 379 9413, or from Scania Spare Parts.

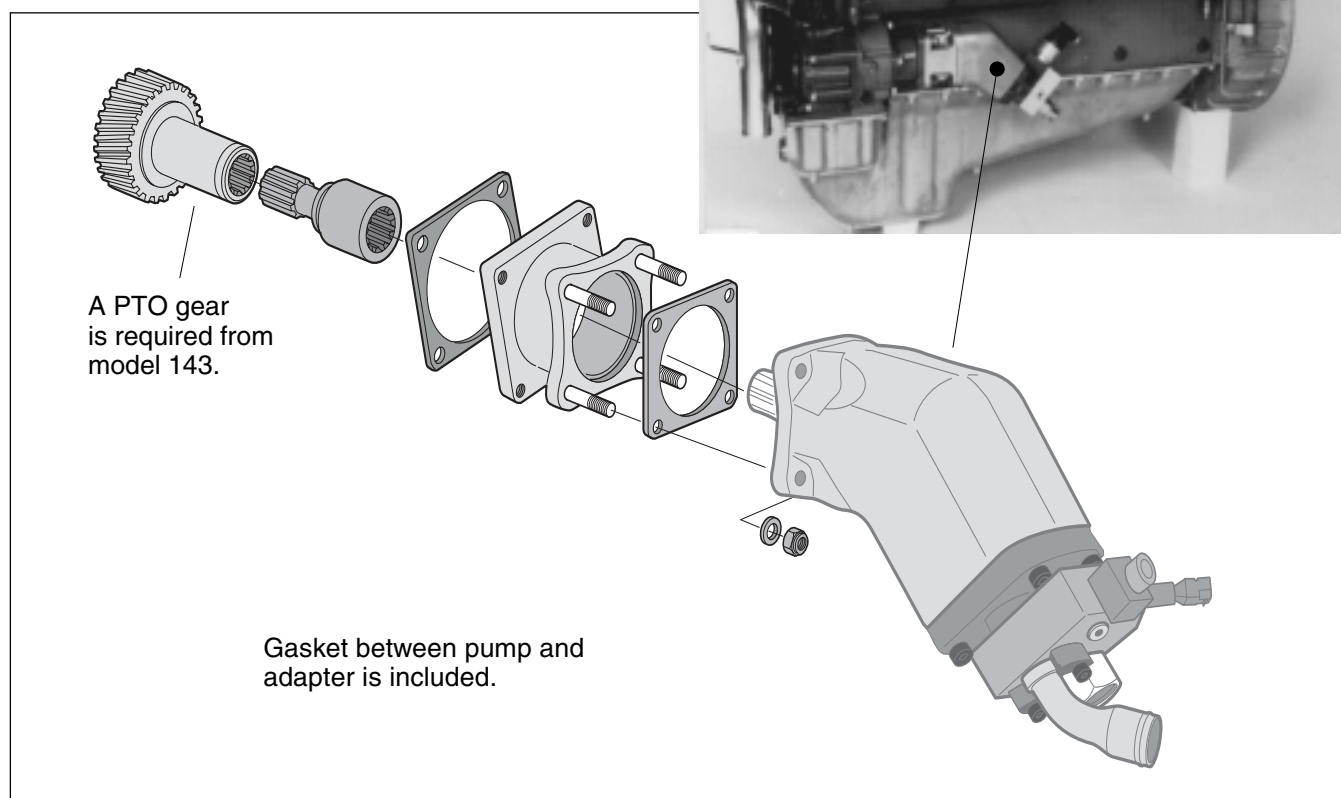
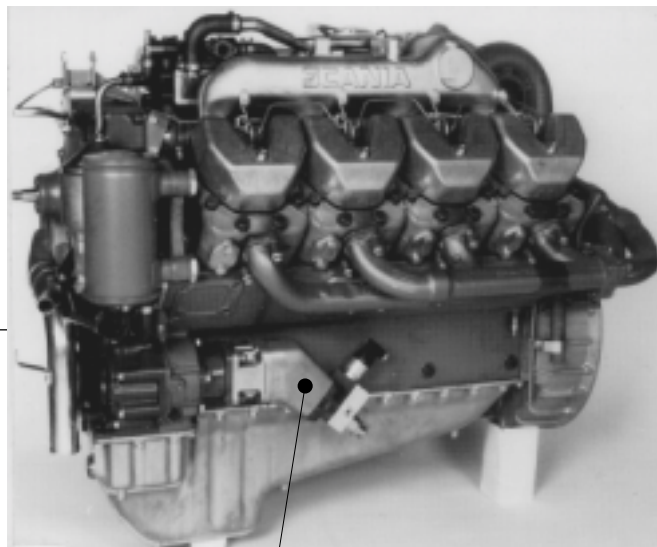

Pump	F1-25	F1-41	F1-51	F1-61	F1-81 ¹⁾
Max. operating pressure [bar]	350	350	285	200	150 ¹⁾
Bypass valve	Required				

1) The engine transmission permits only 150 bar on the F1-81.

Max. torque [Nm]	186
Gear ratio (engine-to-pump)	1 : 1
Pump rotation	Right hand (clockwise)

Designation	Ordering number
ED-140 adapter kit	370 8445
PTO gear (from model 144)	379 9413

NOTE: Model 143 also requires a PTO gear: Scania part no. 259 206.

PTO adapter kit for Scania ED 160 engines

- With the adapter kit, an hydraulic pump (e.g. F1 or VP1) that meets the ISO standard can be installed on the PTO of the Scania 16 liter engine.
- The PTO gear is supplied with the chassis.
- **Please note:** The engine must be ordered with a PTO.

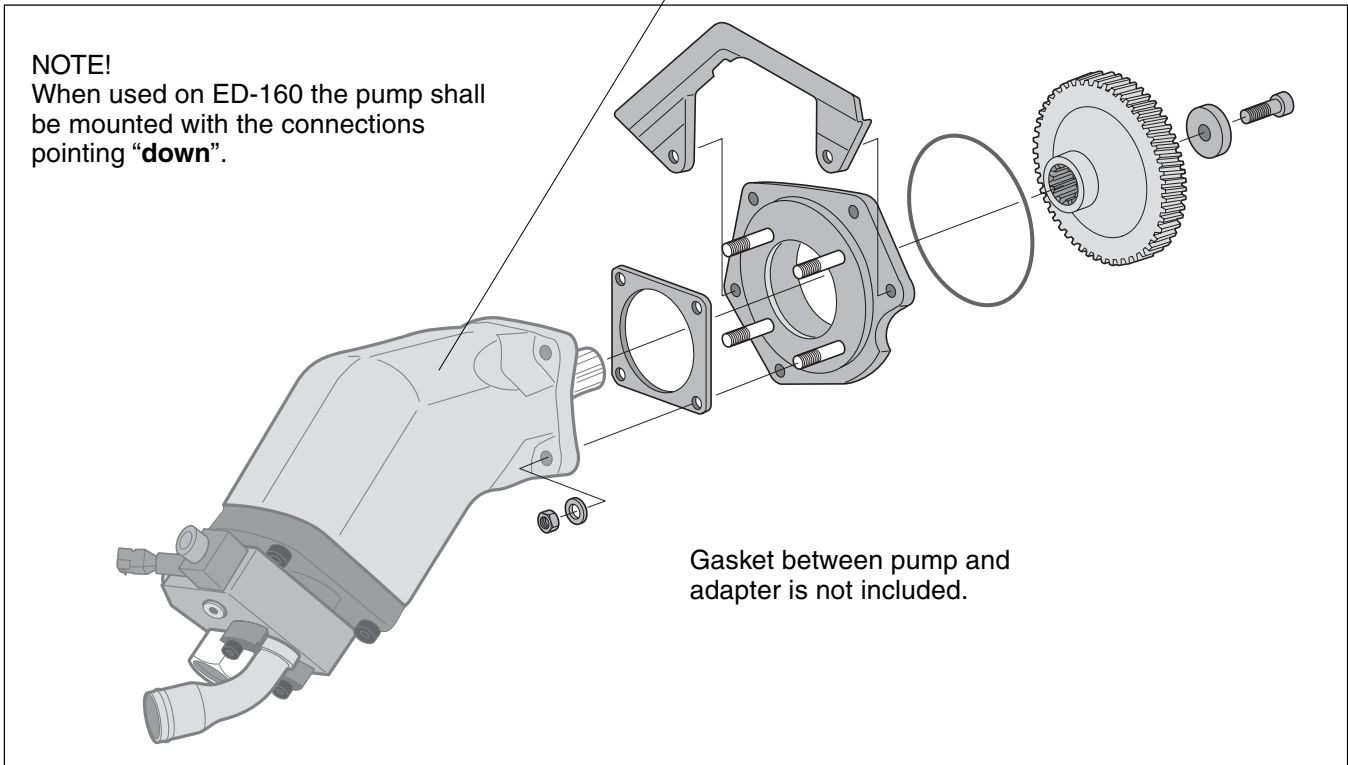

Pump size	F1-25	F1-41	F1-51	F1-61	F1-81	F1-101	F2-53/53	F2-70/35
Max. operating pressure [bar]	350					350	350	350
Bypass valve	Required							

NOTE: Max operating pressures shown for the F2 frame sizes are valid when both ports are pressurized to the same level simultaneously.

Max. torque [Nm]	600
Gear ratio (engine:pump)	1 : 1.19
Pump rotation	Left hand (counter clockwise)

PTO adapter kit	Ordering number
ED-160-F1	378 2001

PTO adapter kit for Mercedes engines (Actros)

- With the adapter kit, an hydraulic pump that meets the ISO standard can be installed on the PTO of the Mercedes V6 and V8 engines.
- The PTO must be ordered with the chassis from the manufacturer or through the distributor; when ordering, state 'N53 without pump'.

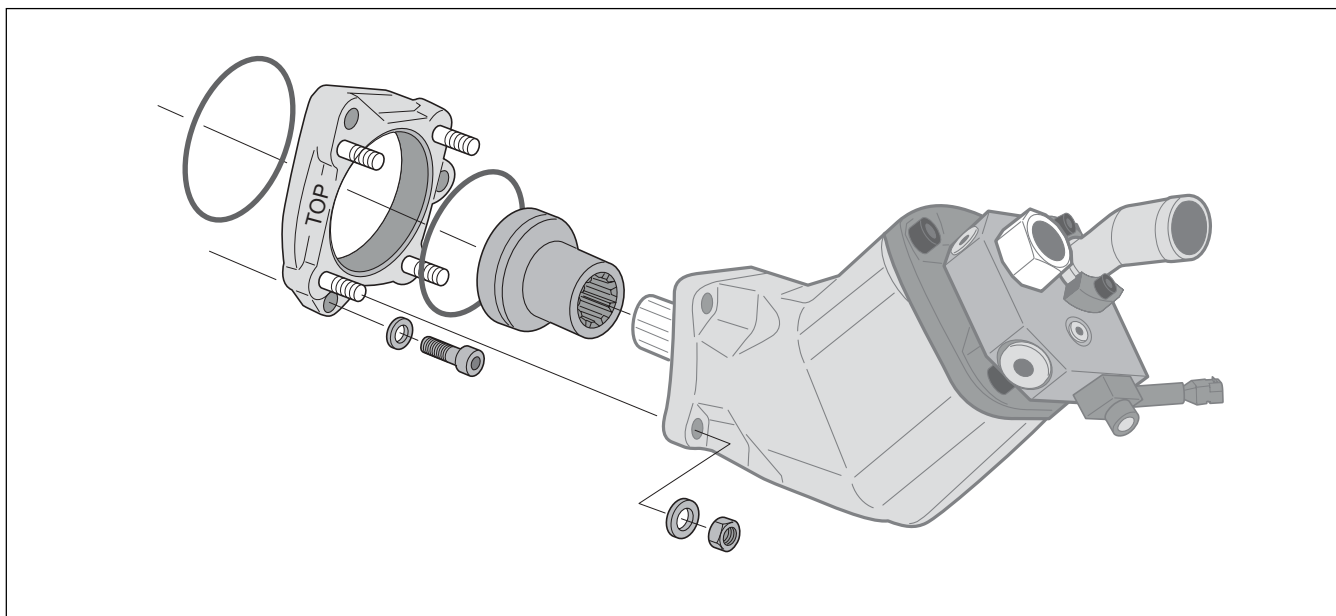

Pump	F1-25	F1-41	F1-51	F1-61	F1-81	F1-101
Max. operating pressure [bar] for short duration, non-frequent work cycles (e.g. tippers and skip loaders)	350	350	350	350	350	270
Max. operating pressure [bar] for continuous work cycles (e.g. cranes and winches)	350	350	350	350	310	225
Bypass valve	Required					

Pump	F2-53/53	F2-70/35	VP1-045	VP1-075
Max. operating pressure [bar] for short duration, non-frequent work cycles (e.g. tippers and skip loaders)	270	270	350	350
Max. operating pressure [bar] for continuous work cycles (e.g. cranes and winches)	230	230	300	300
Bypass valve	Required			

NOTE: Max operating pressures shown for the F2 frame sizes are valid when both ports are pressurized to the same level simultaneously.

Max. non-frequent/continuous torque [Nm]	470/390
Gear ratio (engine-to-pump)	1 : 1.075
Pump rotation	Right hand (clockwise)

Adapter kit	Ordering number
VH-PTO-DB	379 2568

Cardan shafts, pump couplings and mounting brackets

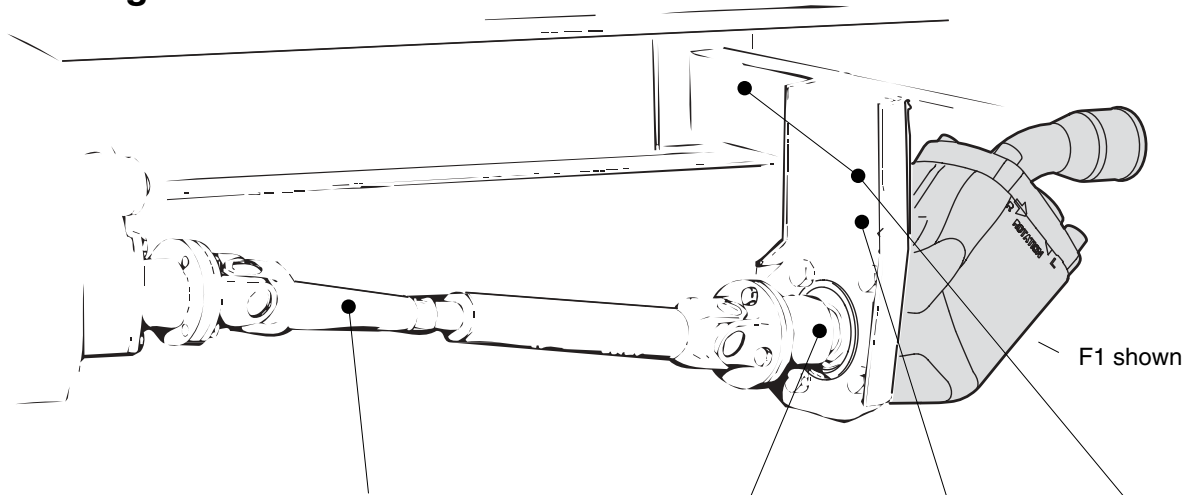

Pump or splitter box type	Cardan shaft kit Type	Cardan shaft kit Ordering no.	Pump coupling Type	Pump coupling Ordering no.	Bracket ordering no.	Bracket kit ordering no.
F1 ¹⁾	SAE 88 ¹⁾	073 001	SAE 88 ¹⁾	370 4628	379 7831	379 7832
F1 (New)	"	"	"	378 0644	"	"
F1 (New)	SAE 97	370 0315	SAE 97	378 0645	379 7831	379 7832
F1	"	"	"	370 4631	"	"
F2	"	"	"	"	"	"
T1-51	"	"	"	"	"	"
VP1	"	"	"	"	"	"
SB154, SB118	SAE 97	370 0315	SAE 97/ DIN 90	Included with splitter box	370 5221	370 5220

1) The SAE 88 cardan shaft and pump coupling can also be used to drive a series F2, T1-51 or VP1 pump providing max allowed shaft torque (below) is not exceeded.

Cardan shaft specifications

Cardan shaft type	Spicer designation	Max length [mm]	Diameter [mm]	Max torque peak/contin. [Nm]	Ordering number
SAE 88	K1140	1220 ²⁾	45	600/300	073 001
SAE 97	K1310	1220 ²⁾	50	1000/500	370 0315

2) One end not welded

PTO flange adapters

Cardan shaft type	PTO flange type	Flange adapter ordering no.
SAE 88	SAE 116	370 5895
SAE 97	SAE 116	370 5896
SAE 116	SAE 97	370 5897³⁾
DIN 90	DIN 100	370 5898
DIN 100	DIN 90	370 5899³⁾

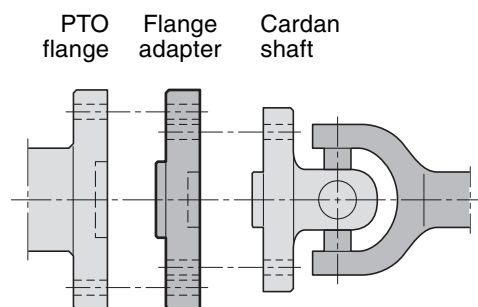

3) **WARNING!** The utilized cardan shaft torque limits (above) must not be exceeded.

Pump couplings

Designation	DIN 90 (fig. 1)
A	90
B	74.5
C	47 h7
D	M8
E ₁	61.5
VP1, F2, F1*	370 4634
F1	378 0642

NOTE: Max torque is limited by the cardan shaft.

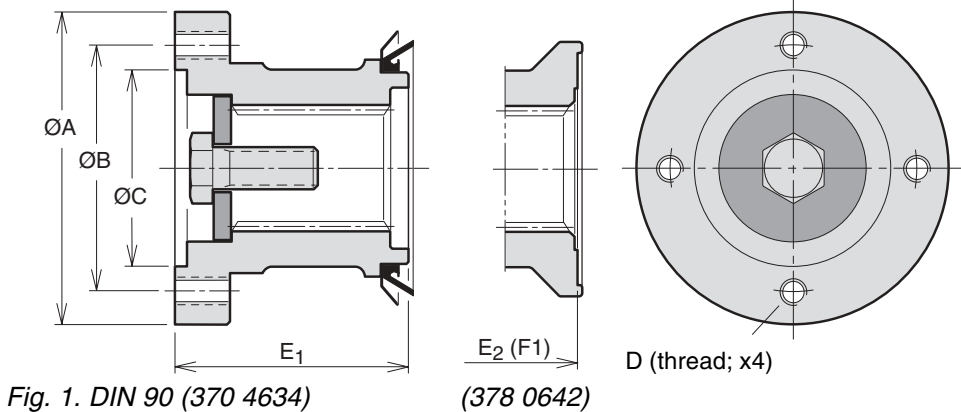

Fig. 1. DIN 90 (370 4634) (378 0642)

Designation	DIN 90 (fig. 2)
A	90
B	74.5
C	47 h7
D	8.2
E ₁	61.5
E ₂ (F1)	57.2
VP1, F2, F1*	370 7423

NOTE: Max torque is limited by the cardan shaft.

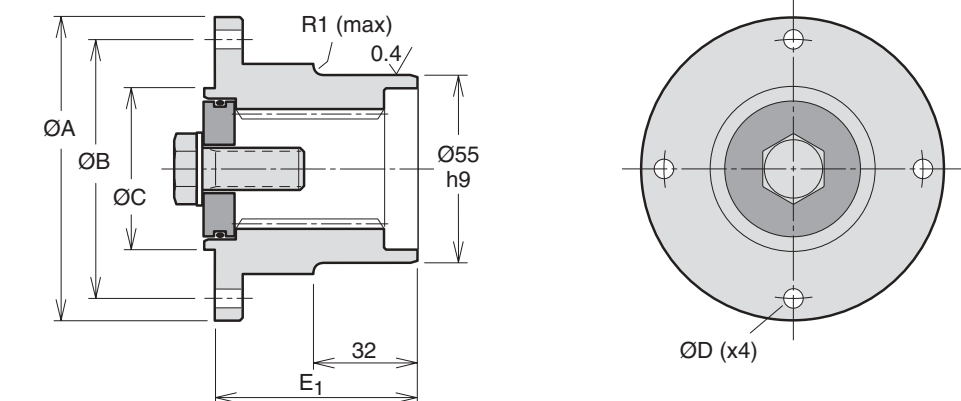

Fig. 2. DIN 90 (370 7423)

Designation	SAE88 (fig. 3)
A	88
B	69.9
C	57.15 H8
D	5/16" UNC
E ₁	65
E ₂ (F1)	59.5
Max torque [Nm] interm./contin.	600/300
VP1, F2, F1*	370 4628
F1	378 0644

NOTE: Max torque is limited by the cardan shaft.

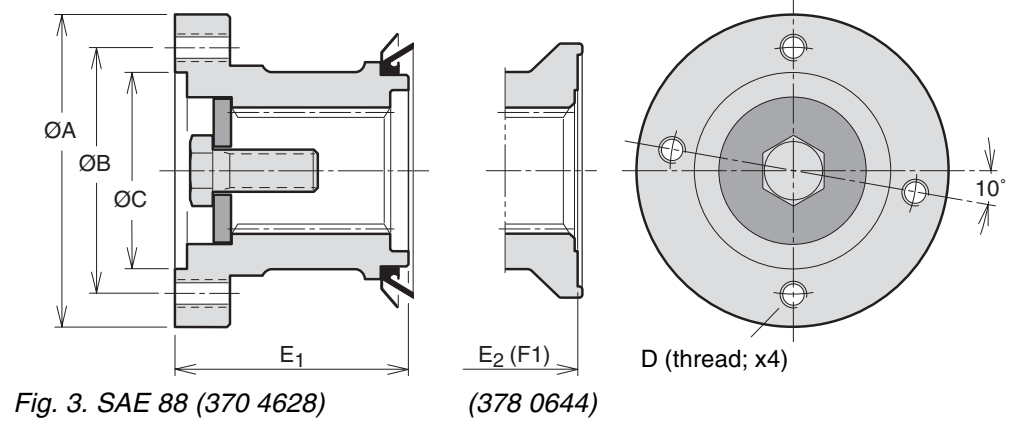

Fig. 3. SAE 88 (370 4628) (378 0644)

Designation	SAE97 (fig. 4)
A	97
B	79.4
C	60.33 H8
D	3/8" UNC
E ₁	65
E ₂ (F1)	59.5
Max torque [Nm] interm./contin.	1000/500
VP1, F2, F1*	370 4631
F1	378 0645

F1* Old versions

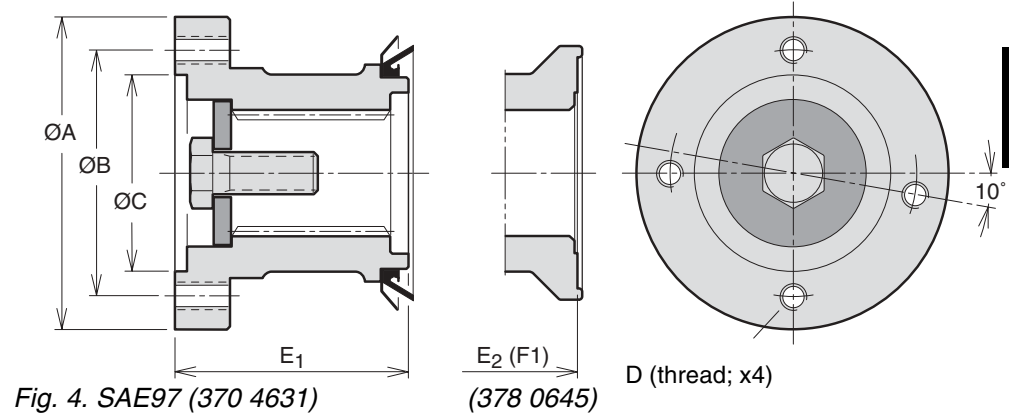

Fig. 4. SAE97 (370 4631) (378 0645)

Return filter and filter indicator

Return flow filter

The low pressure, full flow return filter contains a replaceable fiber glass cartridge with a large flow area. The filter is designed for vertical installation on top of the hydraulic reservoir.

The built-in bypass function opens at 1.6 bar; the overflow is above the cartridge, preventing accumulated dirt inside the filter to enter the flow.

The aluminum housing contains three BSP 1/8" ports which can be utilized for the installation of a filter indicator (see below).

Designation	Return filter
Rated flow (at 30 cSt) [l/min]	230
Cartridge pressure drop at rated flow and 30 cSt [bar]	< 0.1
Degree of filtration ($\beta_{25} \cdot 75$, ISO 4572) [μm]	20 (abs.)
Cartridge collapse rating (ISO 2941) [bar]	8
Inlet port size	BSP 1 1/4"
Weight incl. cartridge [kg]	6
Ordering code, filter ass'y	946 395
filter cartridge only	946 396

NOTE: The flow capacity of the filter should be at least twice the pump flow under normal operating conditions.

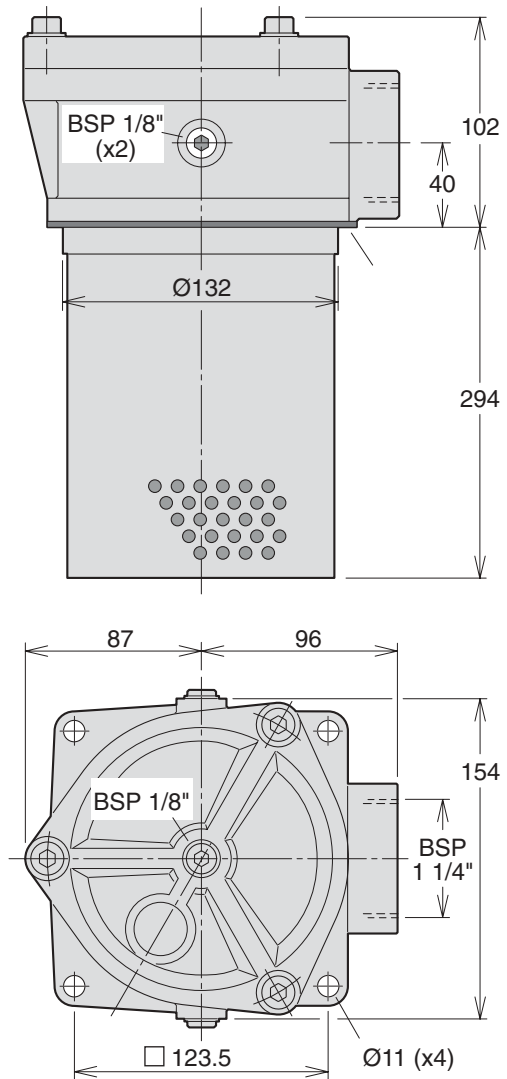

Filter indicator

The visual filter indicator installs in one of the filter housing ports (BSP 1/8"; see above). When the hydraulic system has reached normal operating temperature, the position of the indicator needle shows the condition of the filter cartridge:

- 'Green' - The cartridge is OK.
- 'Red' - Replace the cartridge.

NOTE: A needle in the red area indicates that only part of the oil flow is being filtered which, in turn, means that system components such as the pump will suffer from increased wear.

Designation	Filter indicator
'Green' pressure range [bar]	- 1.0
'Red' pressure range [bar]	1.0 – 1.6
Max pressure (peak) [bar]	2.5
Installation thread	BSP 1/8"
Ordering number	378 0191

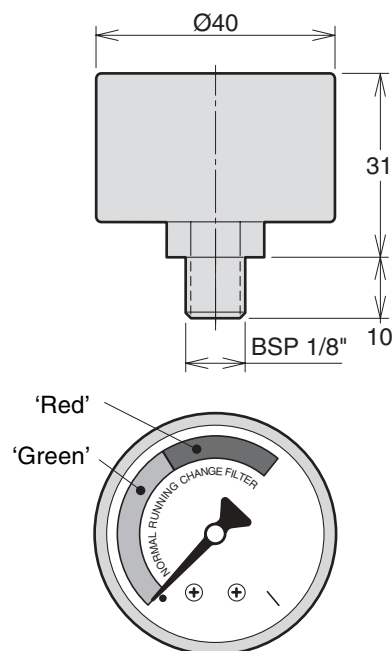

Air breather filter

The oil level in the reservoir can sink drastically when max pump capacity is utilized e.g. to fill the piston end of a cylinder with a large 'piston/piston rod' ratio and the return flow back to tank is comparatively small. A corresponding volume of air must then enter the tank through the breather.

The air breather shown to the right, which mounts on top of the reservoir, is adequately dimensioned for most applications. It has sufficient filtering properties to prevent external dirt from entering the hydraulic system.

The breather has a built-in function which limits the tank pressure to 0.5 bar.

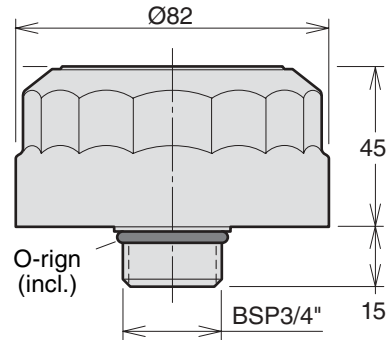

Designation	Air filter
Nominal air flow [l/min]	300
Nominal degree of filtration [μm]	6
Exhaust opening pressure [bar]	0.5
Installation thread	BSP 3/4"
Ordering number	378 0190

NOTE: Preferably, the air flow capacity should be at least twice the pump flow under normal operating conditions.

Check valves

Check valve	Ordering number	Max flow [l/min]	Max press. [bar]	Opening press. [bar]
1/2"	379 1963	75	350	0,5
3/4"	379 1964	130	350	0,5
1"	379 1965	200	350	0,5

Check valve	Dimensions in mm; B and C threads are BSP.						
	A	B	C	ϕ D	E	F	G
1/2"	32	1/2"	1/2"	30	19	35	69
3/4"	36	3/4"	3/4"	34	20	13	65
1"	40	1"	1"	43	20	15	70

NOTE: Free flow is indicated by the arrow.

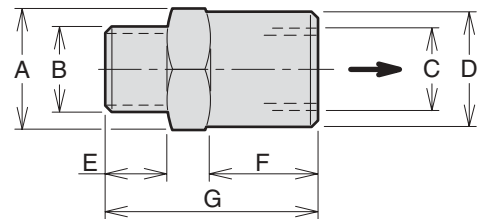

1/2" check valve

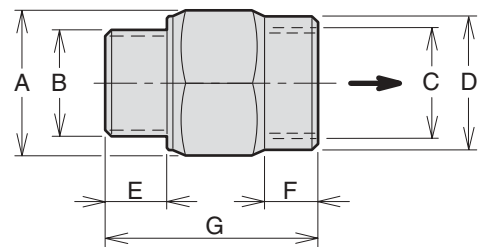

3/4" check valve

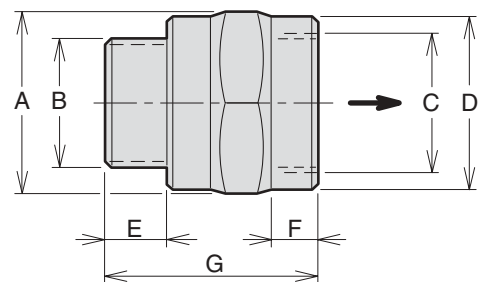

1" check valve

SB splitter boxes

- The splitter box is utilized to drive two pumps, providing two separate, independent flows.
- The high permissible input shaft torque allows two large pumps to be operated simultaneously; make sure, however, that the PTO and the cardan shaft will stand the intended load.
- Pump mounting flange and shaft end must meet the ISO standard.
- The splitter box is available with either of two gear ratios (input shaft-to-pump):
SB 118 - 1:1.18
SB 154 - 1:1.54
- The shipping carton contains all parts required for the installation of the two pumps.

Recommendations

Use the following tables to verify that max pump rpm and max splitter box input torque are not exceeded.

Pump size	Max input speed [rpm]	
	SB 118	SB 154
F1-20	1950	1500
F1-30	1700	1300
F1-40	1525	1200
F1-60	1300	975
F1-80	1100	850
F1-110	1100	850
T1-50	1350	1000

Example: An SB 118 with an F1-20 and an F1-80 can be operated at max 1100 rpm (splitter box input speed), and an SB 154 with the same pumps at max 850 rpm.

Pump size	Pump input torque [Nm] at		
	250 bar	300 bar	350 bar
F1-20	80	95	110
F1-30	120	140	165
F1-40	160	190	225
F1-60	240	285	335
F1-80	315	380	445
F1-110	435	525	610
T1-50	200	240	275
F2-53/53	420	505	590
F2-70/40	435	525	610

Example: An F1-40 at 350 bar requires 225 Nm and an F1-60 at 300 bar 285 Nm.

Total required splitter box input torque:

SB 118: (225 + 285) x 1.18 ≈ 610 Nm.

SB 154: (225 + 285) x 1.54 ≈ 785 Nm

Compare with max permissible torque (interm. 1000 Nm; continuous 700 Nm).

NOTE: If the splitter box should be utilized at close to the max permissible torque and/or max the permissible speed, please contact Parker Hannifin

Installation information

1. Series F1, T1 and F1 (fig. 2)

Valid: At continuous operation less than 30 min. and/or less than 80 kW continuous power output.

- Remove the uppermost drain plug and add 0.5 liter Shell Spirax AX (or similar fluid).
- Install the breather (and the 90° adapter, part no. 378 1069, if required).

NOTE: The F1 or T1 shaft seal **must not** be removed.

2. Series F1 and T1 (left illustration, fig. 3)

Valid: At continuous operation more than 30 min. and/or more than 80 kW continuous power output.

- Remove the shaft seals.
- Install a drain hose between the drain port on the side of the splitter box (see the illustr.) and the reservoir; it must end below the lowest oil level in the reservoir. Utilize one of the 'banjo' couplings included in hose kit 378 1085.

3. Series F1 (right illustration, fig. 3)

Valid: At continuous operation more than 30 min. and/or more than 80 kW continuous power output.

- Install hose kit 378 1085 between the lowest drain port on one of the pumps (see fig. 3) and the BPV-F1-25 och -81 avlastningsventiler lowest drain port of the splitter box.
- Install a drain hose between the drain port on the side of the splitter box and the reservoir; it must end below the lowest oil level in the reservoir. Utilize one of the banjo couplings included in hose kit 378 1085.

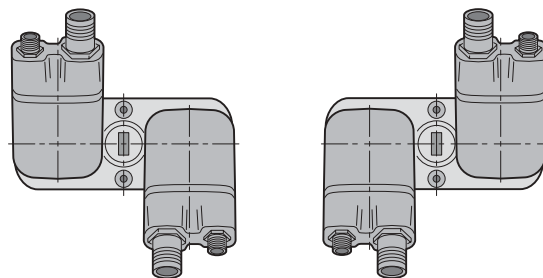

NOTE: The inlet (suction) ports of the pumps should always face the splitter box center, as shown, in order to counteract internal gear forces.

Fig. 1. F1-pumps installed on a splitter box.

Designation	SB 118	SB 154
Gear ratio (inp. shaft-to-pump)	1:1.18	1:1.54
Max input torque intermittent/continuous [Nm]	— 1000/700 —	
Max power	Housing oil temperature must not exceed 75 °C.	
Weight [kg]	— 11.5 —	
Ordering number	379 4981	370 5100

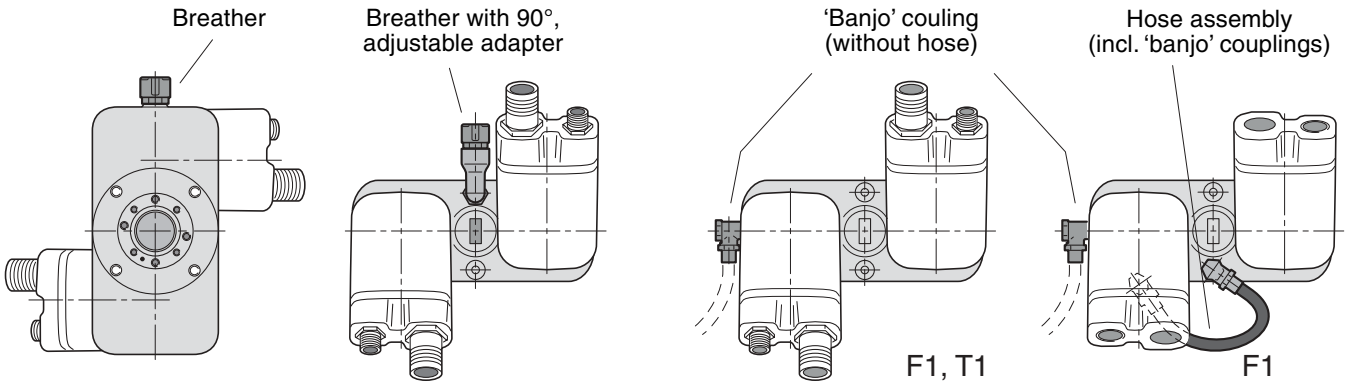

Breather kit (incl. 90°, adjustable adapter and seals):
 Part no. 378 1069.

Fig. 2. Breather installation on the splitter box.

Hose kit (hose sub-ass'y and separate 'banjo' coupling):
 Part no. 378 1085.

Fig. 3. Forced cooling of the splitter box.

Splitter box installation

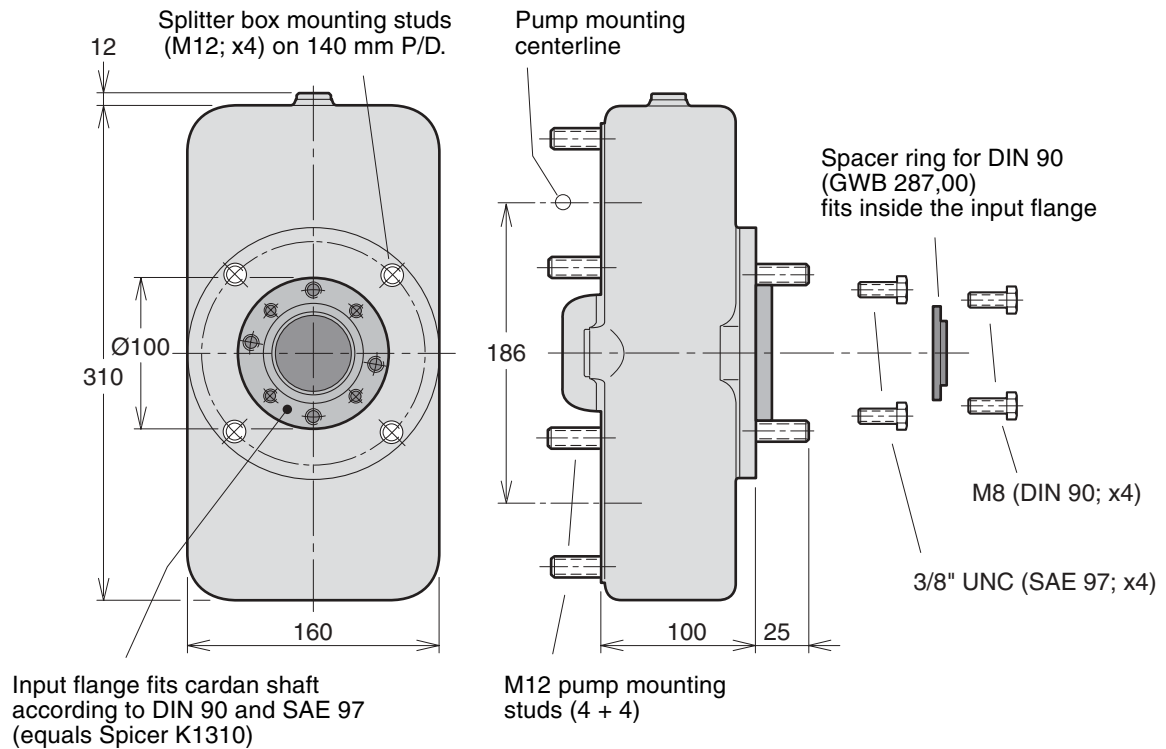

Installation and start up

Installing couplings, sleeves, and gears on the pump shaft.

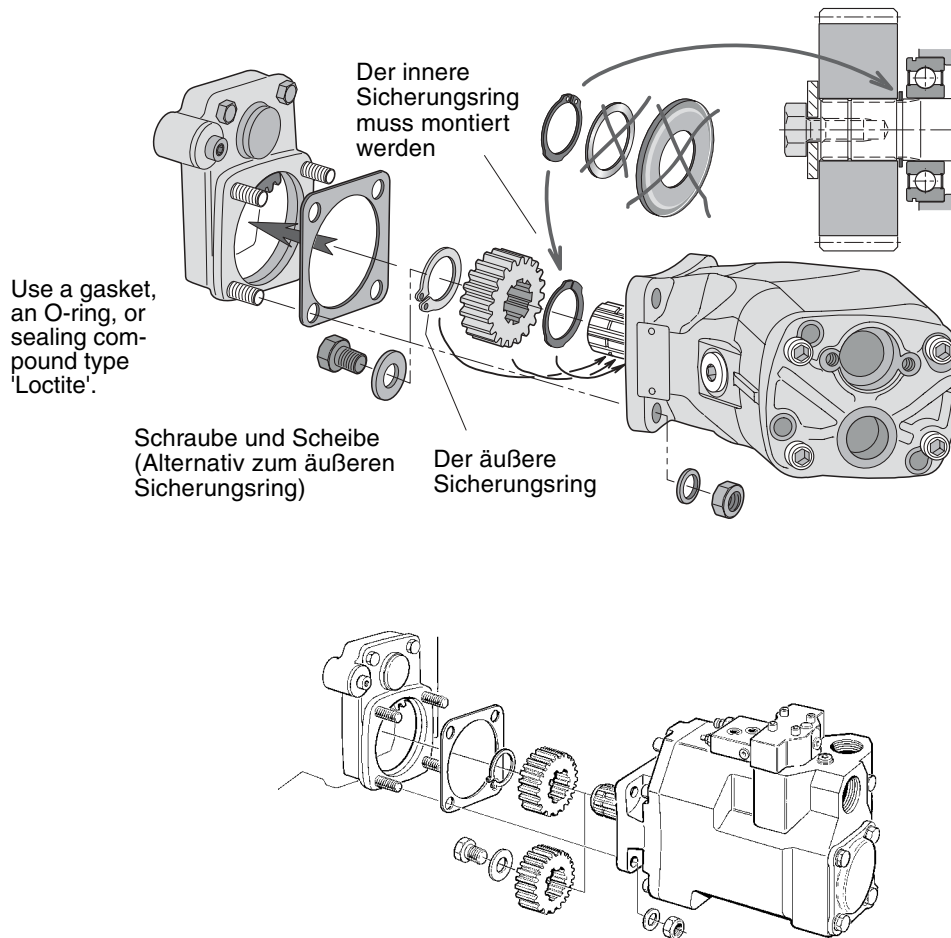

Fig. 6. VP1-to-PTO installation.

IMPORTANT

Our special tool (part no. 370 6851) facilitates installing couplings, sleeves, and gears on the pump shaft. Force must never be used when installing these parts on the F1 shaft.

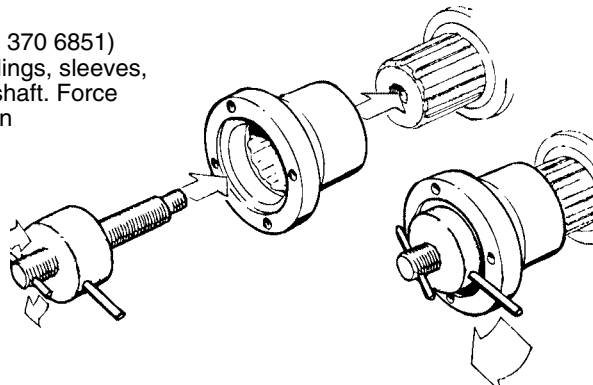
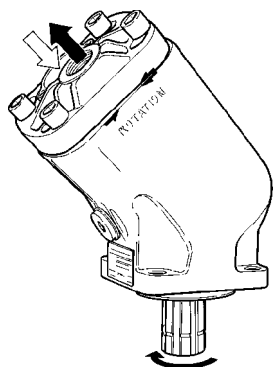

Fig. 7 Mounting tool.

NOTE: When considering installing an F1 on a splitter box, please refer to the installation information provided on pages 58- 59, chapter 11.

Installation and start-up for F1, F2 and T1



Left hand (L.H.; counter clockwise) rotating pump.

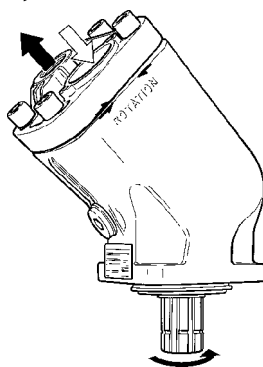

Right hand (R.H.; clockwise) rotating pump.

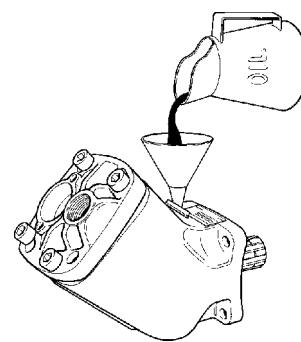

Before start-up, the housing must be filled with hydraulic fluid.

Direction of rotation

The pictures above show direction of flow vs. shaft rotation.

The direction of rotation can be changed (i. e. from right hand to left hand) by turning the end cap.

Remove the four cap screws and turn the end cap about half a turn while making sure it stays in contact with the barrel housing.

Re-fit the cap screws and torque to 80-100 Nm.

Installation

The robust shaft bearings allow the fixed displacement pumps to be mounted either on a bracket, driven by a belt or a cardan shaft, or directly on a PTO.

The top illustration on page 60 shows two ways of installing a gear on the shaft of fixed displacement pumps. The pump shaft spline end usually fits directly in the PTO internal spline coupling.

NOTE: In order to obtain the longest bearing life, the pump should be installed according to the information shown on page 62 "Pump bearing life".

Fluid viscosity

Recommended viscosity:
20 to 30 mm²/s (cSt).

Operating viscosity limits:

- Min 10 mm²/s; max 400 mm²/s.
- At start-up, max 4000 mm²/s.

Fluids

The fixed displacement pumps data shown in the specifications for each pump in chapter 3 to 6 are valid when operating on high quality, mineral based hydraulic oil.

Type HLP (according to DIN 51524) hydraulic oil is suitable as well as biologically degradable fluids like natural and synthetic esters and polyalphaolefins.

The utilized hydraulic fluid shall meet one of the following Swedish standards:

- SS 15 54 34
 - SMR Hydraulic Oil Standard 1996-2.
- Contact Parker Hannifin (Mobile Controls Div.) for further information.

NOTE: - ATF (automatic transmission fluid) and API type CD engine oils may also be useable.

- Seals are made of nitrile rubber; make sure the utilized fluid is compatible with this material.

Fluid temperature

Main circuit: Max 75 °C.

Drain line

Fixed displacement pumps don't need an external drain line as they are internally drained.

Filtration

Filtration should follow ISO standard 4406, code 18/13.

To obtain the longest life of fixed displacement pumps, we recommend an oil cleanliness of 10 µm (absolute).

Start-up

Make sure the entire hydraulic system is clean before filling it with a recommended hydraulic fluid. In particular, make sure the pump is filled (to at least 50%) as the internal leakage does not provide sufficient lubrication at start-up.

NOTE: - The suction port should always be above the pressure port when the pump is installed above the reservoir oil level.

- During operation, the pump must be filled with oil to at least 50%.

NOTE: When considering installing an fixed displacement pump on a splitter box, please refer to the installation information provided on pages 58 and 59, chapter 11.

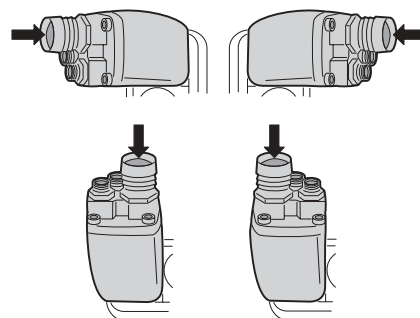

T1-to-PTO installation

- 'Left hand' and 'Right hand' rotation defined in the illustrations on page 61.

- The driving gear of the PTO and the driven gear of the pump are shown in the illustration below. (A right hand rotating pump is shown).

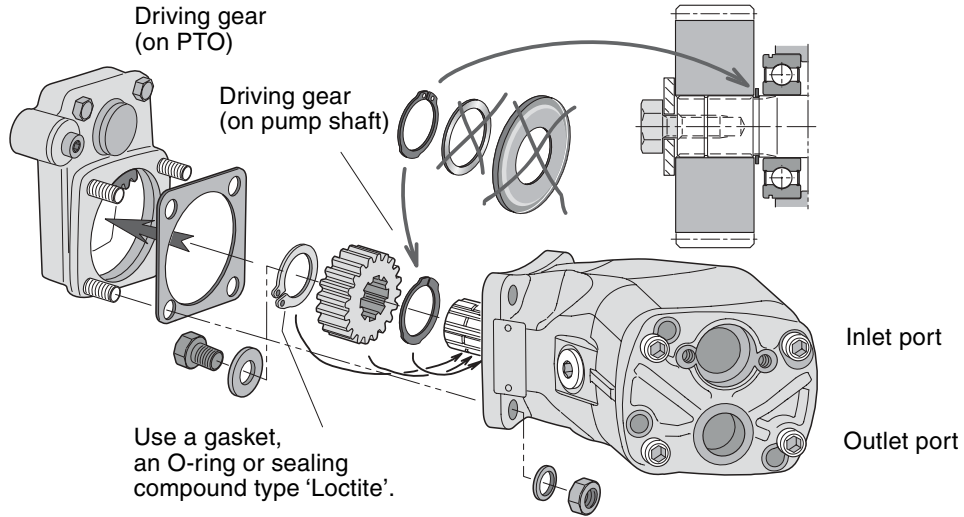

Pump bearing life

Bearing life is dependent on how the pump is installed on the PTO as shown in the illustrations below.

A pump mounted according to fig. 1 gives the lowest bearing life; the highest is obtained when installed according to fig. 3.

Parker Hannifin will assist in determining bearing life in a particular application.

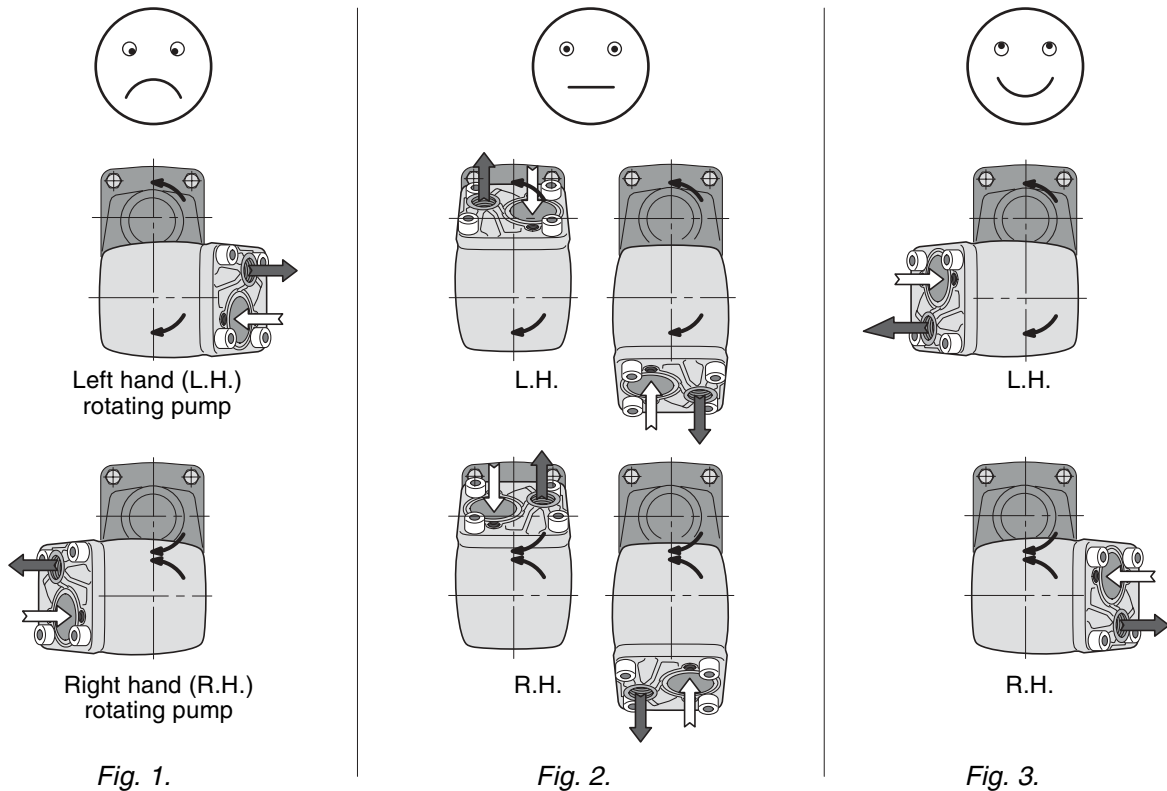

Installation and start-up for VP1

Direction of rotation

The basic VP1 pump is uni-directional; there is a left hand and a right hand version (indicated by the arrow on the side of the VP1 pump (fig. 4 and 5). Consequently, the required direction of rotation must be stated when ordering the pump.

Installation

The VP1 can be installed (close-coupled) directly on a PTO (which meets ISO DIN 5462). Before start-up, the pump must be filled with hydraulic fluid and purged. Utilize the uppermost purge plug (refer to the installation drawing on page 32, chapter 7). Figure 6 shows two ways of installing a gear on the VP1 shaft. On a non-geared or a geared PTO with support bearings, the pump shaft is usually installed directly in the internally splined PTO output shaft.

Hydraulic fluids

The VP1 data shown in the specifications on page 31, chapter 7 are valid when operating on a high quality, mineral based fluid. Hydraulic fluids type HLP (DIN 51524), ATF (automatic transmission fluids), and API type CD engine oils are suitable.

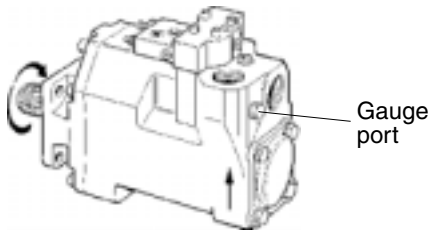

Fig. 4. Left hand rotating pump.

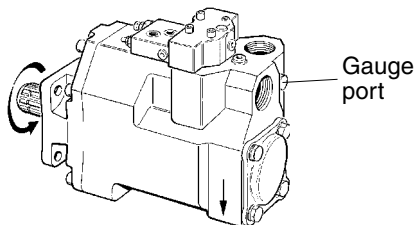

Fig. 5. Right hand rotating pump.

Fluid temperature

Main circuit: Max 75 °C.

Viscosity

Recommended viscosity: 20 to 30 mm²/s (cSt).
Operating viscosity limits: 10 - 400 mm²/s.
At start-up: Max 1000 mm²/s.

Filtration

To obtain long VP1 life, we recommend a filtration level of:

- 25 µm (absolute) in clean environment or at low pressures.
- 10 µm (absolute) in contaminated environment or at high pressures.

Filtration should meet ISO standard 4406, code 18/13.

Drain line

The LS valve *requires a separate drain line*; it should be routed directly to the reservoir (refer to fig. 8).

Start-up

Make sure the entire hydraulic system is clean before filling it with a recommended fluid. In addition, the VP1 pump must be purged to remove any entrapped air in the pump housing; utilize the uppermost purge port (fig. 8).

IMPORTANT

As shown in fig. 8, the pump inlet must always be below the lowest reservoir oil level.

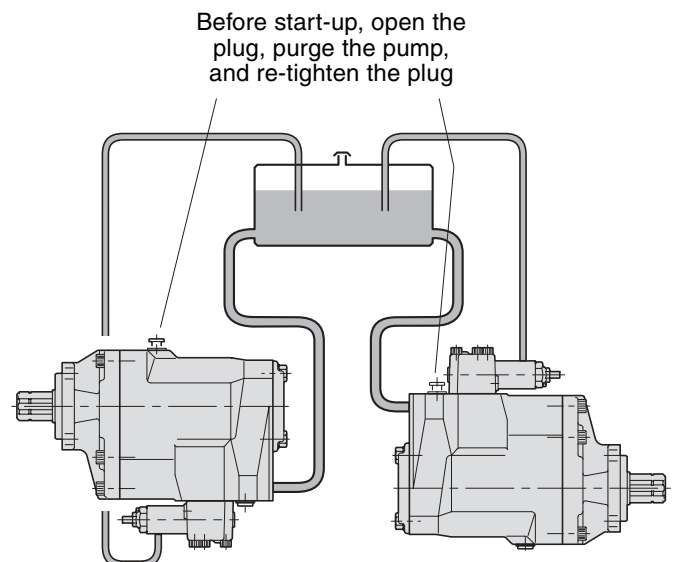

Fig. 8. VP1 should be installed below the reservoir fluid level.

Purging should be performed when the pump is connected to the reservoir and the system is filled with fluid.

Parker PTO's

Parker's power take-off units are designed to meet the requirement of the majority of today's truck applications. The PTO range covers a great many European trucks and is being continually updated to fit new gearboxes. The PTO's are used in a variety of applications such as Tippers, Hook Loaders, Skip Loaders and Cranes, and are specifically designed to close-couple pumps with the current ISO-Standard mounting flange. Alternatively, the units can be fitted with our cardan shaft adaptor to enable them to be used for a wide range of propshaft driven applications.

- Tailor made for the Parker Truck Hydraulics pumps Possibility to close-couple any ISO-standard pump
- Shaft-driven adaptor for other applications Competitively priced
- Easy to install
- Electrical indicator available on latest PTO's.

Parker can, with its range of PTO units, the F1, F2, T1 and VP1 truck pumps, and a great number of accessories, offer the total truck hydraulic package. Parker have in Europe become synonymous for extraordinary quality. Many body builders and chassis manufacturers now include our products as a standard part of their programme."

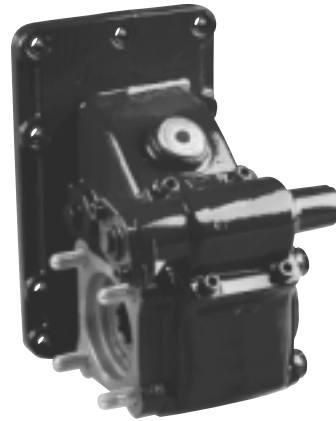

SCANIA



VOLVO



ZF

PTO's from Parker Chelsea

A comprehensive range

Parker Chelsea PTO's are designed to offer more output and shaft options than any other manufacturer, to ensure total compatibility no matter what the vehicle or application. A large percentage of the world's major OEM and transmission manufacturers and bodybuilders depend upon PTO's and auxiliary power products from Parker Chelsea for applications such as trucks, refuse vehicles, fire tenders, construction vehicles like backhoe loaders, excavators, tele handlers, etc. Close coupled pumps are another important accommodation where Chelsea outputs meet both SAE and DIN standards.

CHELSEA®



660 Series PTO

Heavy duty 6-bolt PTO to suit most popular transmission types. Intermittent torque rating up to 500 Nm.



880/885 Series PTO

Heavy duty 8-bolt PTO's available with air shift, hotshift and constant mesh options. Intermittent torque rating up to 678 Nm.



236 Series PTO

'Air/Hotshift' PTO for medium and heavy duty transmissions. Intermittent torque rating up to 406 Nm.



WARNING

FAILURE OR IMPROPER SELECTION OR IMPROPER USE OF THE PRODUCTS AND/OR SYSTEMS DESCRIBED HEREIN OR RELATED ITEMS CAN CAUSE DEATH, PERSONAL INJURY AND PROPERTY DAMAGE.

This document and other information from Parker Hannifin Corporation, its subsidiaries and authorized distributors provide product and/or system options for further investigation by users having technical expertise. It is important that you analyze all aspects of your application, including consequences of any failure, and review the information concerning the product or system in the current product catalogue. Due to the variety of operating conditions and applications for these products or systems, the user, through its own analysis and testing, is solely responsible for making the final selection of the products and systems and assuring that all performance, safety and warning requirements of the application are met.

The products described herein, including without limitation, product features, specifications, designs, availability and pricing, are subject to change by Parker Hannifin Corporation and its subsidiaries at any time without notice.

Offer of Sale

Please contact your Parker representation for a detailed "Offer of Sale".