



Application

Parker D81 series hydraulic directional control valves are high performance, solenoid controlled, pilot operated, two-stage, 4-way valves. They are available in 2 or 3 position styles and are manifold mounted. These valves conform to NFPA's D08/CETOP 8 mounting pattern.

Operation

Parker's D81 series directional valves consist of a five chamber style main body, a case hardened sliding spool, and a pilot valve or pilot operators (hydraulic or pneumatic).

Features

- Easy access mounting bolts.
- 350 Bar (5000 PSI) pressure rating.
- Flows to 622 L/M (160 GPM) depending on spool.
- Choice of four operator styles.
- Rugged four land spools.
- Low pressure drop.
- Phosphate finish.

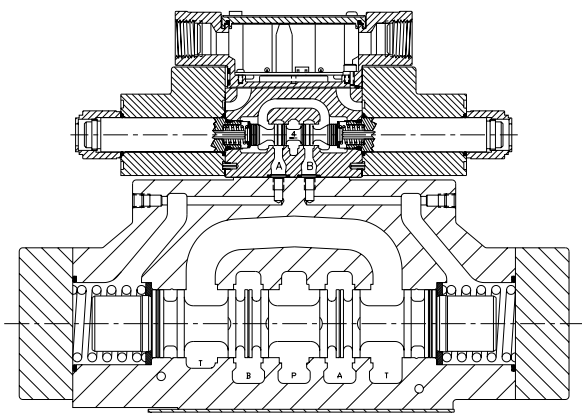

D81VW Solenoid Operated Conduit Box Style

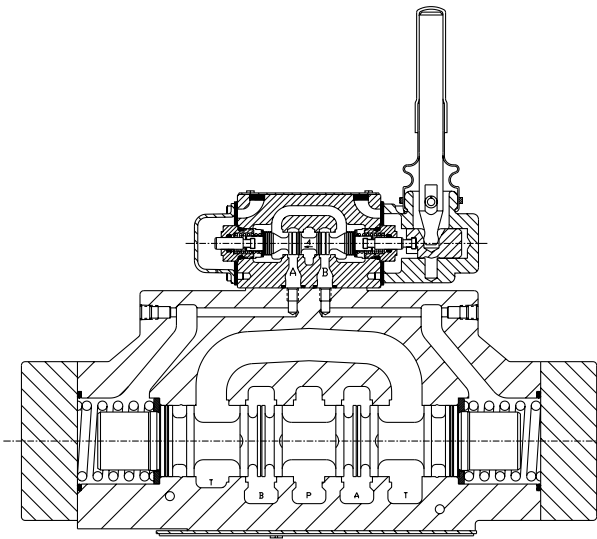

D81VL Lever Operated

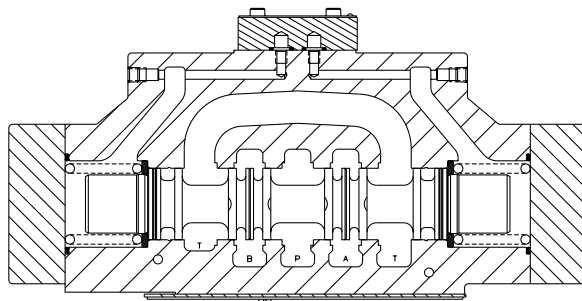

D8P Oil Pilot Operated

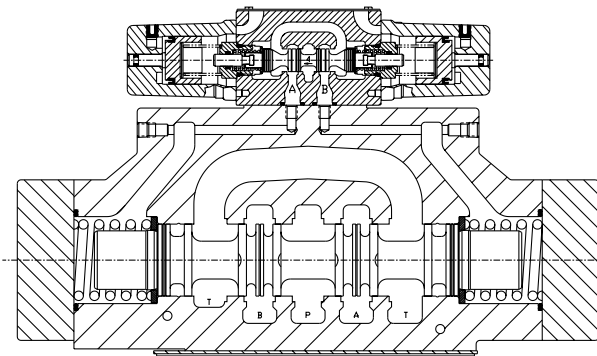

D81VA Air Pilot Operated

General Description

The D81VW is a five-chamber, pilot operated, solenoid controlled, directional control valve. It is available in 2 or 3-position styles. They are manifold or subplate mounted valves which conform to NFPA's D08/CETOP 8 mounting pattern.





Operation

Parker pilot operated valves are standard with low shock spools and pilot orifice. The orifice can be removed if a faster shift is required. It is recommended, however, that all systems operating above 2000 PSI use the standard valve to avoid severe shock.

Features

- Low pressure drop design
- Hardened spools provide long life
- Fast response option available
- Wide variety of voltages and electrical connection options
- Explosion proof availability
- No tools required for coil removal
- Repairable manual override for easy seal replacement

Specifications

Mounting Pattern	NFPA D08, CETOP 8, NG25
Maximum Operating Pressure	350 Bar (5000 PSI) Standard CSA  207 Bar (3000 PSI)
Maximum Tank Line Pressure	Internal Drain Model: 102 Bar (1500 PSI) Standard 205 Bar (3000 PSI) Optional External Drain Model: 350 Bar (5000 PSI) CSA  102 Bar (1500 PSI)
Maximum Drain Pressure	102 Bar (1500 PSI) Standard 205 Bar (3000 PSI) Optional CSA  102 Bar (1500 PSI)
Minimum Pilot Pressure	5.1 Bar* (75 PSI)
Maximum Pilot Pressure	350 Bar (5000 PSI) Standard CSA  207 Bar (3000 PSI)
Nominal Flow	302 Liters/Min (80 GPM)
Maximum Flow	See Quick Reference Chart

* 6.9 Bar (100 PSI) for spool configurations 002, 007,008, 009 & 012.

2502-A5.p65, dd

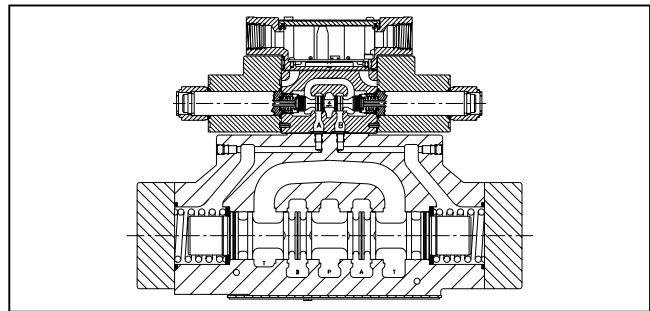
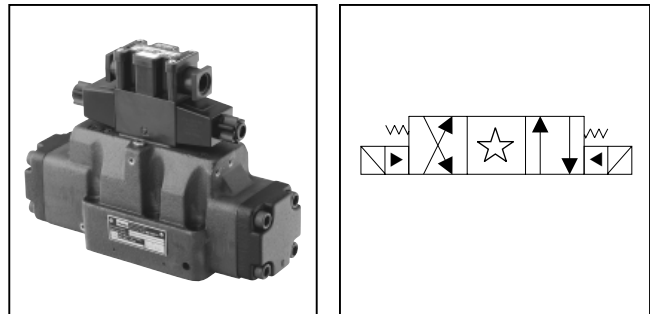

Response Time

Nominal response times (milliseconds) are measured at 350 Bar (3000 PSI) and 312 L/M (80 GPM) with various pilot pressures as indicated.

Solenoid Type	Pilot Pressure	Pull-In		Drop-Out	
		Std	Fast	Std	Fast
DC	500	140	100	70	70
	1000	125	90	76	76
	2000	100	70	70	70
AC	500	100	60	60	60
	1000	85	50	60	60
	2000	60	30	60	60

Because of the high drain line pressure transients generated during shifting, use of the fast response option is not recommended for pilot pressures exceeding 205 Bar (2000 PSI)



A

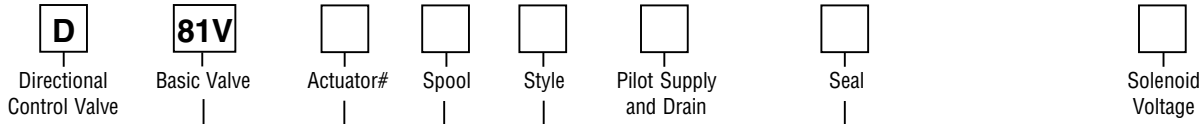

NFPA D08, CETOP 8,
 DIN NG25
 High Flow, D03 Pilot

Code	Description
W	Solenoid, Wet Pin, Screw-in
HW	Reversed Wiring

Code	Description
N	Nitrile
V	Fluorocarbon

Code	Description
1	Internal Pilot, External Drain
2	External Pilot, External Drain
3	Internal Pilot w/Check, External Drain
4*	Internal Pilot, Internal Drain
5	External Pilot, Internal Drain
6	Internal Pilot w/Check Internal Drain

Code	Description
A	24/50 VAC
D	120 VDC
G	198 VDC
J	24 VDC
K	12 VDC
L	6 VDC
N	220/50 VAC
Q	100/60 VAC
R	24/60 @VAC
T	240/60 - 220/50 VAC
U	98 VDC
Y	120/60 - 110/50 VAC
Z	250 VDC

Valve schematic symbols are per NFPA/ANSI standards, providing flow P to A when energizing solenoid A. Note operators reverse sides for #008 and #009 spools. See installation information for details. To configure per DIN standards (A coil over A port, B coil over B port) code valves as D81VHW***.

* Not available with 002, 007, 008, 009, 014 and 030 spools.

Code	Symbol	Code	Symbol
001		011	
002		012	
003		014	
004		015	
005		016	
006		020*	
007		030**	
008*		081	
009**		082	

Code	Description	Symbol
B*	2 position, spring offset P to A	
C	3 position, spring centered	
D*	2 position, detent, P to A and B to T	
E	2 position, spring centered and P to B	
F	2 position, spring offset P to A and centered	
H*	2 position, spring offset P to B	
K	2 position, spring centered and P to A	
M	2 position, spring offset P to B and centered	

* 008 & 020 spools have closed crossover.
 ** 009 & 030 spools have open crossover.

* Available with 020 and 030 spools.

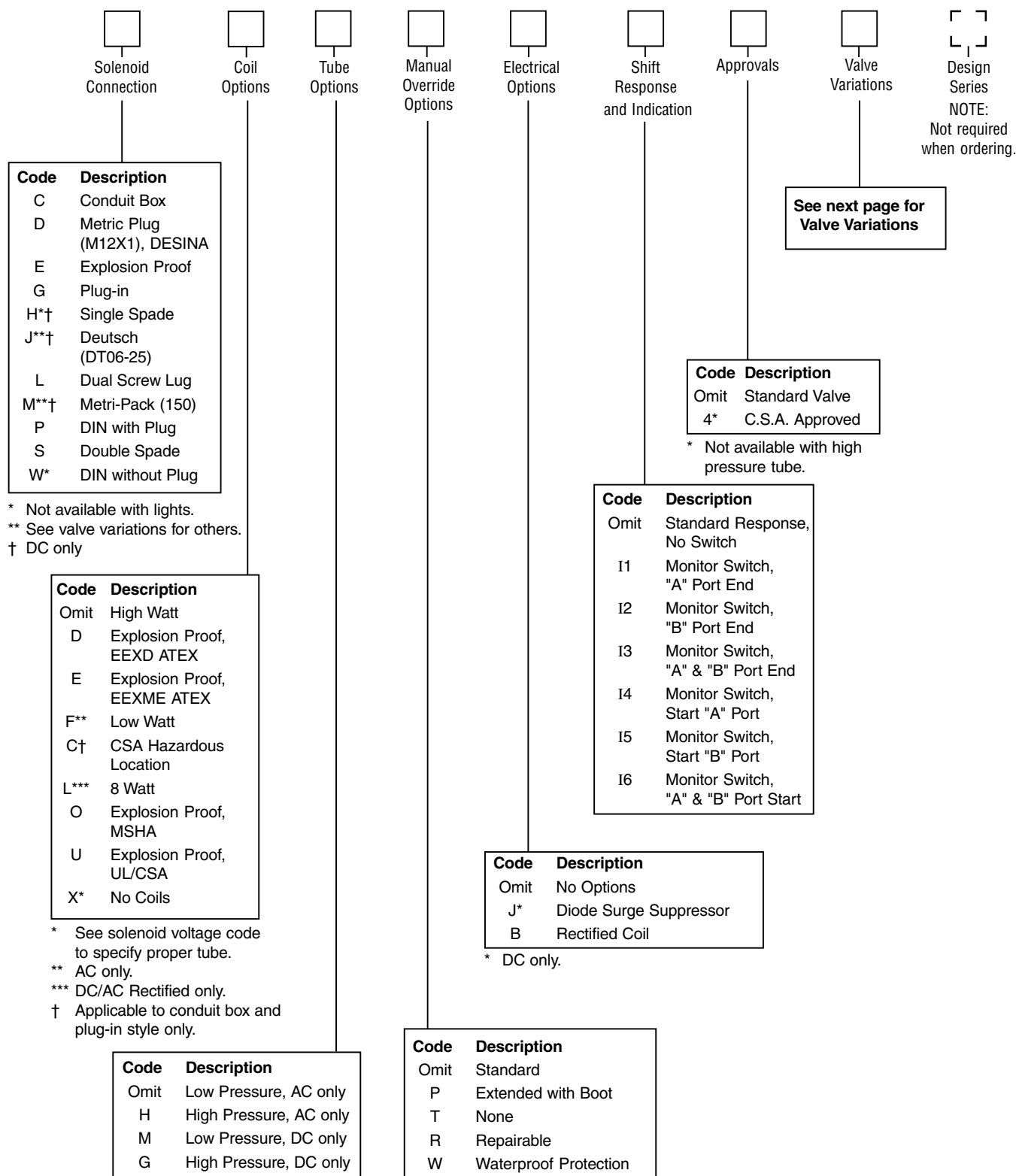

Valve Weight:

Double Solenoid 19.6 kg (43.2 lbs.)

Standard Bolt Kit: BK228

Valve Variations

A

Code	Description	D31*W	D61*W	D81*W	D101*W
5	Signal Lights				
6	Manaplug – Brad Harrison Mini				
7A	Manaplug – Brad Harrison (12x1) Micro				
56	Manaplug (Mini) with Lights				
7B	Manaplug (Micro) with Lights (D1 only)				
20	Fast Response				
1A	Manaplug (Mini) Single Sol. 5-pin				
1B	Manaplug (Micro) Single Sol. 5-pin				
1C	Manaplug (Mini) Single Sol. 5-pin, with Lights				
1D	Manaplug (Micro) Single Sol. 5-pin, with Lights				
1E	Manaplug (Mini) Single Sol. 5-pin, with Stroke Adjust "A" & "B" End				
1F	Manaplug (Micro) Single Sol. 5-pin, with Stroke Adjust "A" & "B" End				
1G	Manaplug (Mini) Single Sol. 5-pin, with Stroke Adjust "A" & "B" End and Lights				
1H	Manaplug (Micro) Single Sol. 5-pin, with Stroke Adjust "A" & "B" End and Lights				
2B	On Board Bus – SDS				
2C	Manaplug (Micro) with Bus Wiring				
3A	Pilot Choke Meter Out				
3B	Pilot Choke Meter In				
3C	Pilot Pressure Reducer				
3D	Stroke Adjust "B" End				
3E	Stroke Adjust "A" End				
3F	Stroke Adjust "A" & "B" End				
3G	Pilot Choke Meter Out with Lights				
3H	Pilot Choke Meter In with Lights				
3J	Pilot Pressure Reducer with Lights				
3K	Pilot Choke Meter Out with Stroke Adjust "A" & "B" End				
3L	Pilot Choke Meter Out, Stroke Adjust "A" & "B" End with Lights and Manaplug and Brad Harrison Mini				
3M	Pilot Choke Meter Out, Pilot Pressure Reducer, Stroke Adjust "A" & "B" End				
4B	Protection Cap for Monitor Switch				
4D	Twist & Lock Override (Old 5426)				
4E	Push Manual Override (Old x5450)				



Quick Reference Data

Model	Spool Symbol	Maximum Flow, LPM (GPM) 350 Bar (5000 PSI) w/o Malfunction	Model	Spool Symbol	Maximum Flow, LPM (GPM) 350 Bar (5000 PSI) w/o Malfunction
D81V*001		624 (160)	D81V*009		624 (160)
D81V*002		624 (160)	D81V*011		624 (160)
D81V*003		624 (160)	D81V*012		312 (80)
D81V*004		624 (160)	D81V*014		312 (80)
D81V*005		624 (160)	D81V*015		624 (160)
D81V*006		624 (160)	D81V*016		624 (160)
D81V*007		312 (80)	D81V*020 D81V*030		624 (160)

* See Universal Spool Chart for additional options.

D81V* Series Pressure Drop Chart

The following chart provides the flow vs. pressure drop curve reference for the Series D81V* valve by spool type.

VISCOSITY CORRECTION FACTOR							
Viscosity (SSU)	75	150	200	250	300	350	400
% of ΔP (Approx.)	93	111	119	126	132	137	141

Curves were generated using 100 SSU hydraulic oil. For any other viscosity, pressure drop will change per chart.

D81VW Pressure Drop Reference Chart – Curve Number					
Spool No.	P-A	P-B	P-T	A-T	B-T
001	1	1	–	3	4
002	2	2	5	4	6
003	1	1	–	4	4
004	1	1	–	4	6
005	2	2	–	3	4
006	2	2	–	3	4
007	1	2	8	3	6
009	2	2	7	3	4
011	1	1	–	3	4
012	1	1	9	3	4
014	2	1	8	6	3
015	2	2	–	5	5
016	2	2	–	4	3
020/030	2	2	–	3	4

Performance Curves

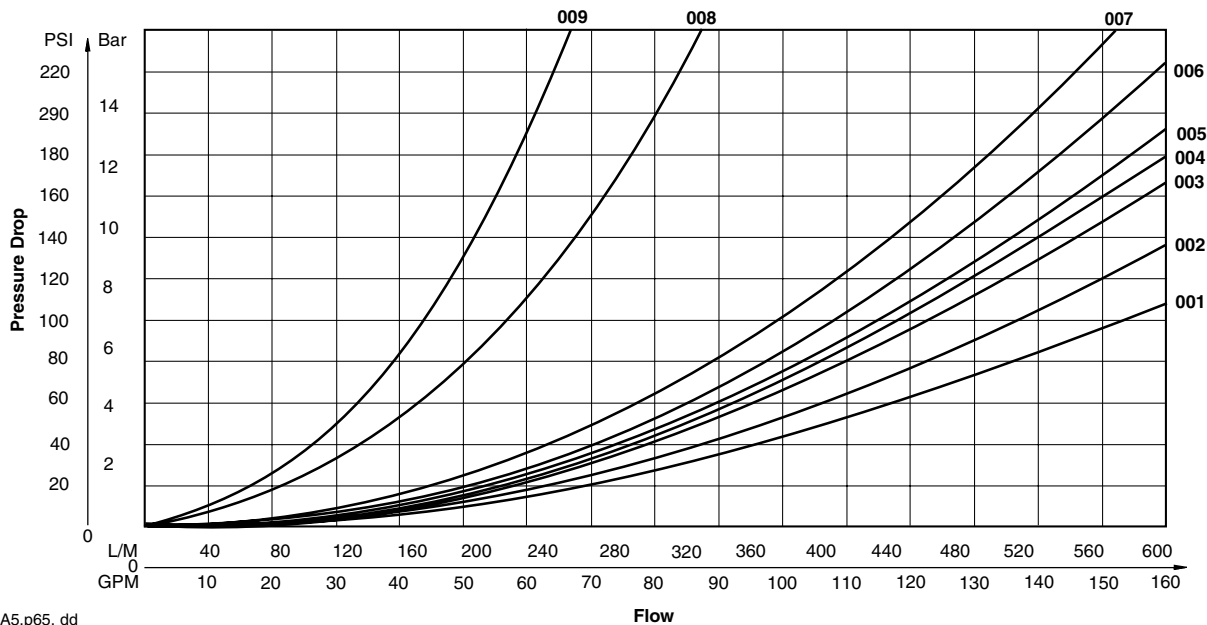

HVD = Hydraulic Valve Division HCD = Hydraulic Controls Division

		Spool Number	Closed Crossover	Open Crossover	Symmetrical	Standard	Spool Symbol					Spool: D1V*	Spool: D1V*	Spool: D3W	Spool: D31DW	Spool: D41	Spool: D41*W	Spool: D61VW	Spool: D81/D91	Spool: D101VW	Spool: D111
A	0						B	D1VW: D1VHW	D1V*: A/C/P/D/G/L	D3DW/D31DW	Double Monitor Switch	HCD	Double Monitor Switch	HVD	HCD	HVD	HCD				
		001	x		x	x															
		002		x	x	x															
		003	x			x															
		004	x		x	x															
		005	x			x															
		006	x		x	x															
		007		x		x															
		008	x		x	x															
		009		x		x															
		010	x			x															
		011		x		x															
		012		x	x	x															
		014		x		x															
		015	x			x															
		016	x			x															
		020B	x			x															
		020D	x			x															
		020H	x			x															
		021	x			x															
		022	x			x															
		023		x																	
		026B	x			x															
		026H	x			x															
		030B		x		x															
		030D		x		x															
		030H		x		x															
		031	x																		
		032	x																		
		033																			
		034	x																		
		035	x																		
		038																			
		039																			
		042	x		x																
		043B																			
		043H																			
		044		x																	
		044B		x																	
		044H		x																	
		047																			

Spools shown may be nonstandard. Please contact HVD for availability.

HVD = Hydraulic Valve Division HCD = Hydraulic Controls Division

		Closed Crossover	Open Crossover	Symmetrical	Standard	Spool Symbol				Spool: D1V*	Spool: D1V*	Spool: D3W	Spool: D31DW	Spool: D41	Spool: D41*W	Spool: D61VW	Spool: D81/D91	Spool: D101VW	Spool: D111
Spool Number						A		0		B	D1VW: D1VHW	D1V*: A/C/P/ D/G/L	D3DW/ D31DW	Double Monitor Switch	HCD	Double Monitor Switch	HVD	HCD	HVD
049B	x				x														
049H	x																		
051	x																		
054			x																
055																			
056	x																		
058			x																
059			x																
061			x																
062			x																
065B																			
065H																			
066																			
067	x																		
068B	x																		
068H	x																		
069B	x																		
069H	x																		
070B																			
070H																			
071B	x																		
071H	x																		
073																			
074H																			
076	x				x														
078	x				x														
079																			
080																			
081	x			x	x														
081B																			
081H																			
082	x			x	x														
083B	x																		
083H	x																		
084																			
085																			
098																			
099																			
100																			
101B	x																		

Spools shown may be nonstandard. Please contact HVD for availability.



Solenoid Ratings

Insulation System	Class F
Allowable Deviation from rated voltage	-10% to +15% for DC and AC rectified coils -5% to +5% for AC Coils
Armature	Wet pin type
CSA File Number	LR60407
Environmental Capability	DC Solenoids are rated at NEMA 4 (IP67) or better when properly wired and installed. Contact HVD for AC coil applications.

Explosion Proof Solenoid Ratings*

U.L. & CSA (EU)	Class I, Div 1 & 2, Groups C & D Class II, Div 1 & 2, Groups E, F & G As defined by the NEC
M.S.H.A. (EO)	Complies with 30CFR, Part 18
ATEX (ED)	Complies with ATEX requirements for: Exd, Group IIB; EN50014: 1999+ Amds. 1 & 2, EN50018: 2000
CSA Hazardous Location	Class II, Groups E, F & G

* Allowable Voltage Deviation +/- 10%
 Note that AC coils are single frequency only.

Code		Voltage	In Rush Amps Amperage	In Rush Amps D1VW VA @ 3MM	Holding Amps D1VW	Watts D1VW	Resistance D1VW
Voltage Code	Power Code						
A		24/50 VAC, High Watt	7.00 Amps	168 VA	2.65 Amps	28 W	1.67 ohm(s)
D	L	120 VDC	N/A	N/A	0.09 Amps	10 W	1584.00 ohm(s)
			N/A	N/A	0.26 Amps	30 W	528.00 ohm(s)
E		24/60 VAC, High Watt	6.00 Amps	144 VA	1.85 Amps	20 W	1.67 ohm(s)
		24/50 VAC, High Watt	7.00 Amps	168 VA	2.65 Amps	28 W	1.67 ohm(s)
G	L	198 VDC	N/A	N/A	0.05 Amps	10 W	3920.40 ohm(s)
			N/A	N/A	0.15 Amps	30 W	1306.80 ohm(s)
J	L	24 VDC	N/A	N/A	0.44 Amps	10 W	51.89 ohm(s)
			N/A	N/A	1.32 Amps	30 W	17.27 ohm(s)
K	L	12 VDC	N/A	N/A	0.88 Amps	10 W	12.97 ohm(s)
			N/A	N/A	2.64 Amps	30 W	4.32 ohm(s)
L	L	6 VDC	N/A	N/A	1.67 Amps	10 W	3.59 ohm(s)
			N/A	N/A	5.00 Amps	30 W	1.20 ohm(s)
M	L	9 VDC	N/A	N/A	1.11 Amps	10 W	8.12 ohm(s)
			N/A	N/A	3.35 Amps	30 W	2.67 ohm(s)
P		110/50 VAC			0.38 Amps	19 W	135.00 ohm(s)
R		24/60 VAC, High Watt	8.00 Amps	192 VA	2.70 Amps	27 W	1.40 ohm(s)
	F	24/60 VAC, Low Watt	6.67 Amps	160 VA	2.20 Amps	23 W	1.52 ohm(s)
S	***Specials***	SEE BELOW					
T		240/60 VAC, High Watt	0.77 Amps	185 VA	0.26 Amps	25 W	134.50 ohm(s)
		220/50 VAC, High Watt	0.82 Amps	180 VA	0.31 Amps	27 W	134.50 ohm(s)
	F	240/60 VAC, Low Watt	0.70 Amps	168 VA	0.22 Amps	21 W	145.00 ohm(s)
	F	220/50 VAC, Low Watt	0.75 Amps	165 VA	0.26 Amps	23 W	145.00 ohm(s)
U	L	98 VDC	N/A	N/A	0.10 Amps	10 W	960.00 ohm(s)
X	L	16 VDC	N/A	N/A	0.63 Amps	10 W	25.60 ohm(s)
Y		120/60 VAC, High Watt	1.55 Amps	186 VA	0.49 Amps	25 W	33.70 ohm(s)
		110/50 VAC, High Watt	1.65 Amps	182 VA	0.58 Amps	27 W	33.70 ohm(s)
	F	120/60 VAC, Low Watt	1.40 Amps	168 VA	0.42 Amps	21 W	36.50 ohm(s)
	F	110/50 VAC, Low Watt	1.50 Amps	165 VA	0.50 Amps	23 W	36.50 ohm(s)
	L*B	120/60 VAC, 10 Watt	0.63 Amps	83 VA	0.18 Amps	10 W	75.00 ohm(s)
	L*B	110/50 VAC, 10 Watt	0.73 Amps	79 VA	0.20 Amps	10 W	75.00 ohm(s)
	*H	120/60 VAC, High Pressure	1.40 Amps	168 VA	0.50 Amps	26 W	36.50 ohm(s)
	*H	110/50 VAC, High Pressure	1.48 Amps	163 VA	0.60 Amps	28 W	36.50 ohm(s)
Z	L	250 VDC	N/A	N/A	0.04 Amps	10 W	6875.00 ohm(s)
			N/A	N/A	0.13 Amps	30 W	1889.64 ohm(s)
Specials	S	Other voltages/frequencies may be available Contact HVD for more information					
Explosion Proof Solenoids							
R		24/60 VAC	7.63 Amps	183 VA	2.85 Amps	27 W	1.99 ohm(s)
T		240/60 VAC	0.76 Amps	183 VA	0.29 Amps	27 W	1.34 ohm(s)
N		220/50 VAC	0.77 Amps	169 VA	0.31 Amps	27 W	1.38 ohm(s)
Y		120/60 VAC	1.60 Amps	192 VA	0.58 Amps	27 W	33.50 ohm(s)
P		110/50 VAC	1.47 Amps	162 VA	0.57 Amps	27 W	34.70 ohm(s)
Q		100/60 VAC	1.90 Amps	192 VA	0.70 Amps	27 W	38.60 ohm(s)
K		12 VDC	N/A	N/A	2.75 Amps	33 W	4.36 ohm(s)
J		24 VDC	N/A	N/A	1.38 Amps	33 W	17.33 ohm(s)
D		120 VDC	N/A	N/A	0.28 Amps	33 W	420.92 ohm(s)
Z		250 VDC	N/A	N/A	0.13 Amps	33 W	1952.66 ohm(s)

Inch equivalents for millimeter dimensions are shown in (**)

Conduit Box, Double AC Solenoid

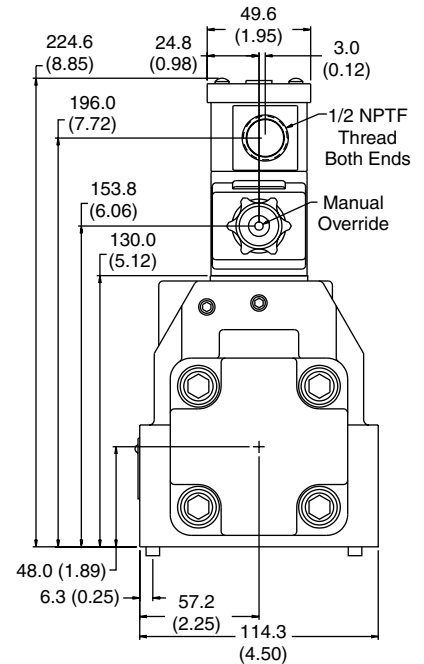
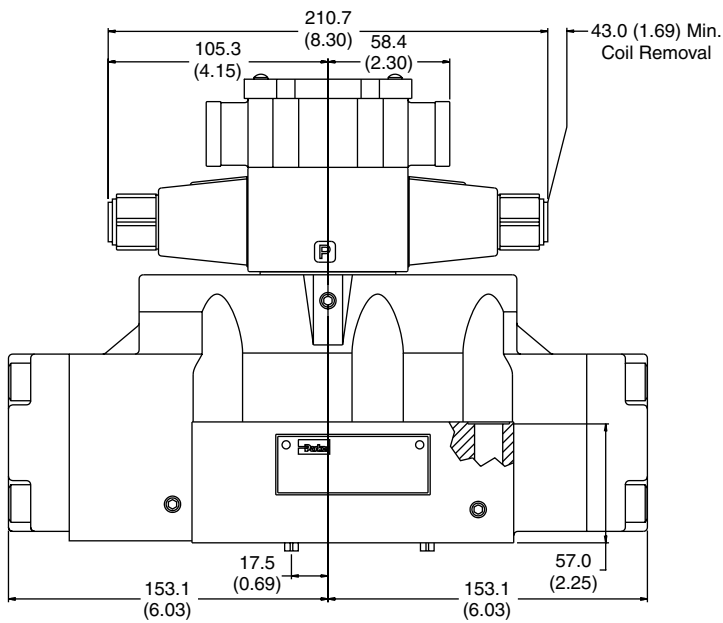
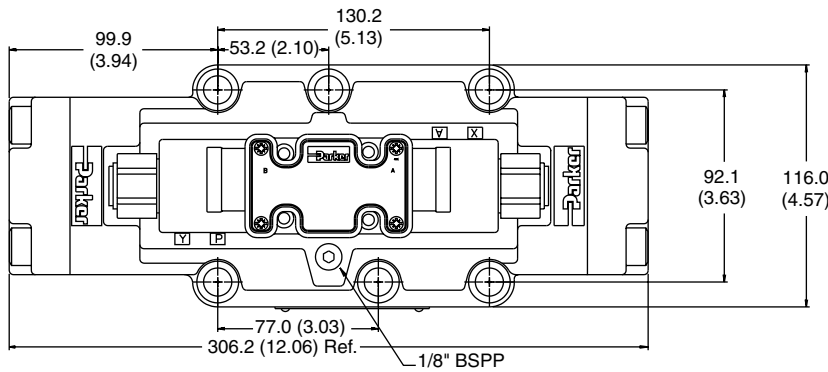

1/16 Plug for Variations 2 & 5
Torque to:
11.67 ±1.67 Nm
(105 ±15 in-lbs)
Do Not Loctite

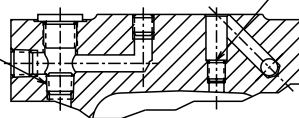

M6 x 1 Plug for Variations 1, 2 & 3
Torque to:
1.78 ±0.22 Nm
(16 ±2 in-lbs)
Do Not Loctite

Inch equivalents for millimeter dimensions are shown in (**)



Conduit Box and Stroke Adjust, Double AC Solenoid

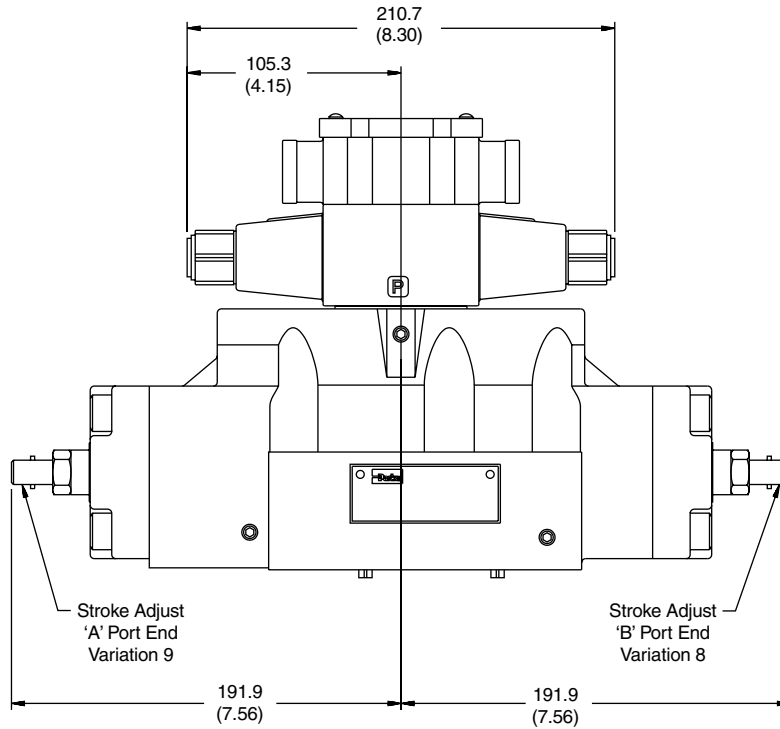

**Conduit Box and Pilot Choke Control,
Double AC Solenoid**

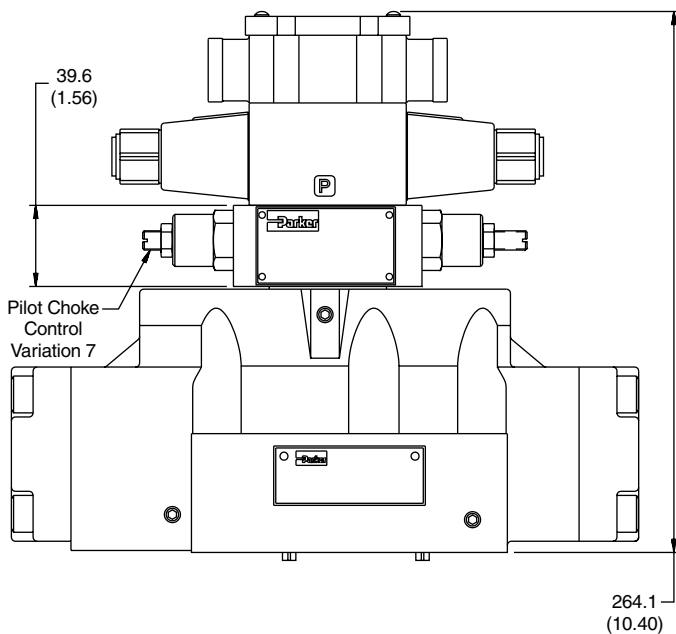

Conduit Box, Single AC Solenoid

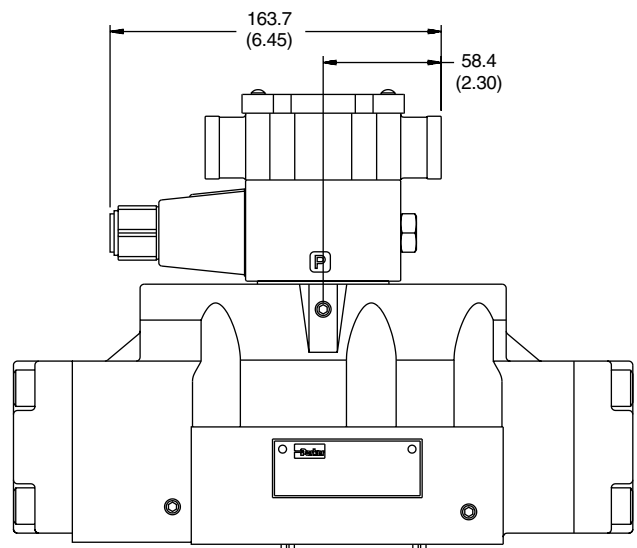

Inch equivalents for millimeter dimensions are shown in (**)

Plug-In Conduit Box, Double DC Solenoid

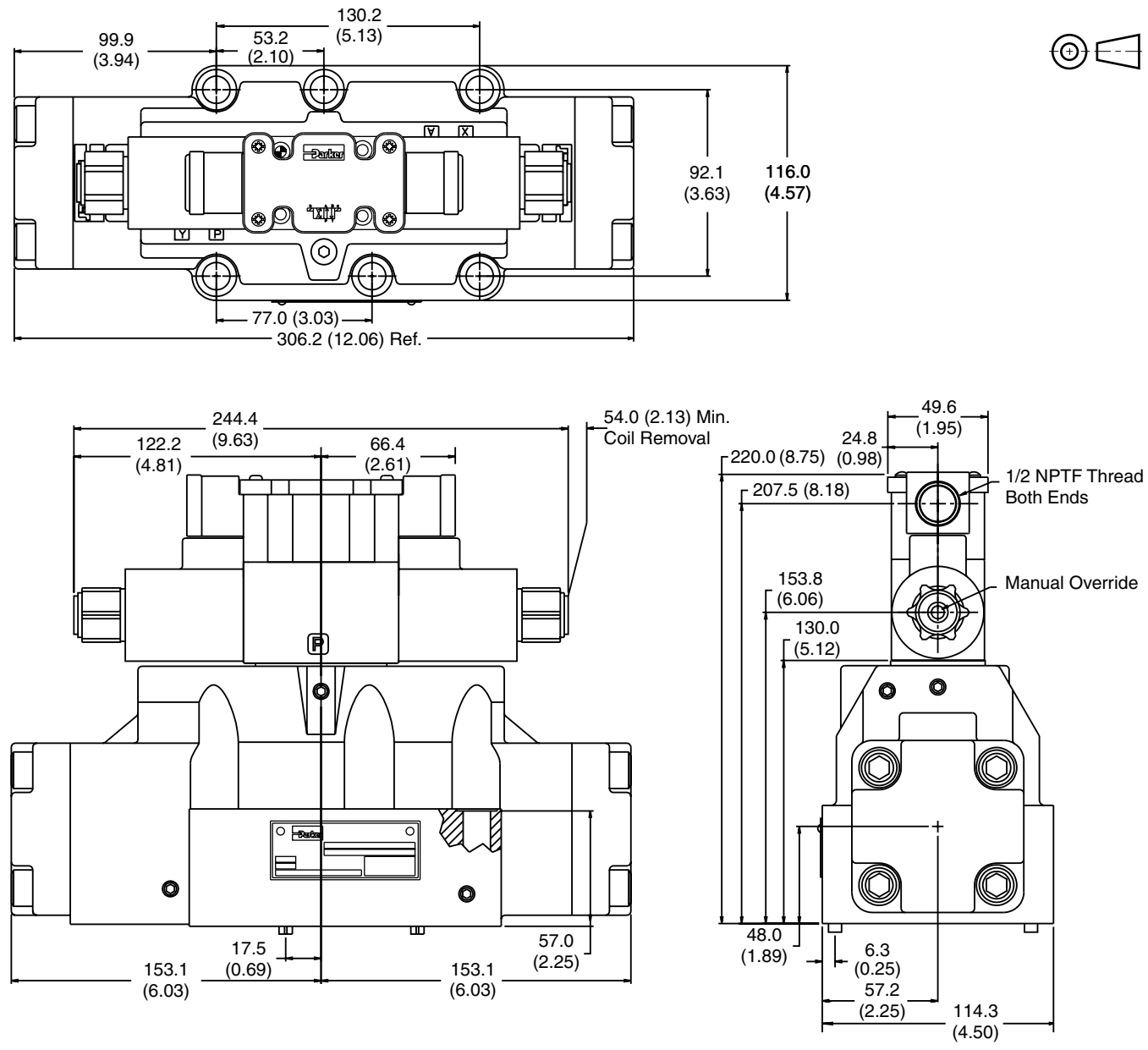

Inch equivalents for millimeter dimensions are shown in (**)



Plug-In Conduit Box and Stroke Adjust, Double DC Solenoid

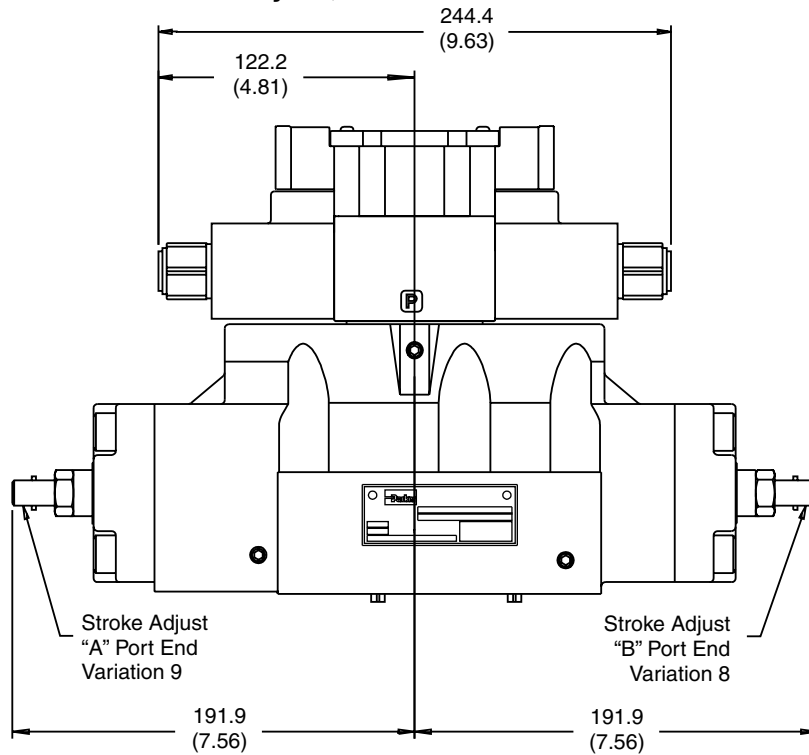

Hirschmann and Pilot Choke Control, Double DC Solenoid

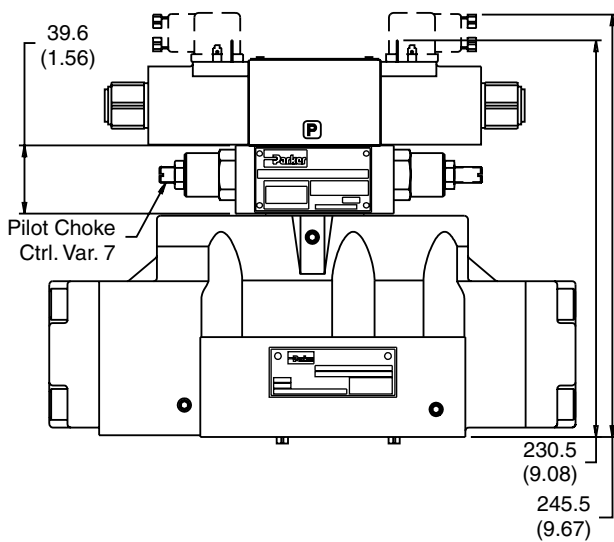

Plug-In Conduit Box, Single DC Solenoid

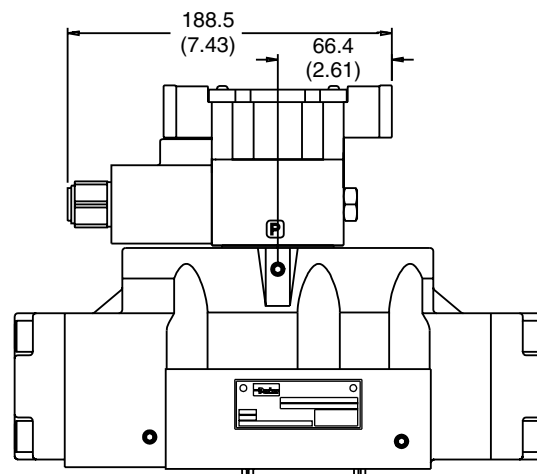

A

FOR MAXIMUM VALVE RELIABILITY, ADHERE TO THE FOLLOWING INSTALLATION INFORMATION.

The following is important installation information which applies to all directional control valves described in this catalog.

Mounting Position

Detent – Horizontal
Spring Offset – Unrestricted
Spring Centered – Unrestricted

Fluid Recommendations

Premium quality hydraulic oil with a viscosity range between 150-250 SSU (32-54 cst.) At 100°F (38°C) is recommended. The absolute operating viscosity range is from 80-1000 SSU (16-220 cst.). Oil should have maximum anti-wear properties and rust and oxidation treatment.

Fluids and Seals

Valves using synthetic, fire-resistant fluids require special seals. When phosphate esters or its blends are used, FLUOROCARBON seals are required. Water-glycol, water-in-oil emulsions and petroleum oil may be used with STANDARD seals.

Filtration

For maximum valve and system component life, the system should be protected from contamination at a level not to exceed 125 particles greater than 10 microns per milliliter of fluid (SAE class 4/ISO 16/13).

Silting

Silting can cause any sliding spool valve to stick and not spring return if held under pressure for long periods of time. The valve should be cycled periodically to prevent sticking.

Special Installations

Consult your Parker representative for any application requiring the following:

- Pressure above rating
- Fluid other than those specified
- Oil temperature above 160°F (71.1°C)
- Flow path other than normal

Mounting Patterns

Series	NFPA	Size
D81V*, D8P	D08	1"

Torque Specifications

The recommended torque values for the bolts which mount the valve to the manifold or subplate are as follows: 135.6 Nm (100 ft-lbs).

Series D81VW, D81VA, D81VL**Tank and Drain Line Surges**

If several valves are piped with a common tank or drain line, flow surges in the line may cause an unexpected spool shift. Detent style valves are most susceptible to this. Separate tank and drain lines should be piped in installations where line surges are expected.

Electrical Characteristics (Detented Spool)

Only a momentary energizing of the solenoid is necessary to shift and hold a detented spool. Minimum duration of the signal is 0.1 seconds for both AC and DC voltages. Spool position will be held provided the spool centerline is in a horizontal plane, and not shock or vibration is present to displace the spool.

Electrical Failure or Loss of Pilot Pressure (D81VA)

Should electric power fail or loss of pilot pressure occur, spring offset and spring centered valves will shift to the spring held position. Detented valves will stay in the last position held before power failure. If main flow does not fail or stop at the same time power fails, machine actuators may continue to function in an undesirable manner or sequence.

Pilot/Drain Characteristics**Pilot Pressure:**

75 to 3000 PSI (5.1 to 207 Bar)

100 PSI (6.9 Bar) for spools 002, 007, 008, 009 & 012

External: An oil source sufficient to maintain minimum pilot pressure must be connected to the "X" port of the main body. When using the external pilot variation, a 1/16" pipe plug must be present in the main body pilot passage. (For details see Dimension pages.) This plug will be furnished in valves ordered with pilot code 2, 3, 5 or 6.

Internal: Flow is internally ported from the pressure port of the main valve body to the "P" port of the pilot valve. The pressure developed at the "P" port of the pilot valve must be 75 PSI (5.1 Bar) minimum at all times or 100 PSI (6.9 Bar) for spools 002, 007, 008, 009 & 012.

Integral Check: Valves using internal pilot and internal drain with an open center spool (spools 2, 7, 8 & 9) can be ordered with an integral check valve in the pressure port of the main valve codes 3 & 6. Pilot oil will be internally ported from the upstream side of this check to the "P" port of the pilot valve, ensuring sufficient pilot pressure. A 1/16" pipe plug will be present in the main body. The "X" port in the subplate must be plugged when using the integral check.

Pilot Valve Drain: Maximum pressure 1500 PSI (102 Bar), 3000 PSI (207 Bar) optional.

External: When using an external drain, a M6 x 1 x 6mm long set screw must be present in the main body drain passage. (For details see Dimension pages.) This plug will be furnished in valves ordered with drain code 1, 2 or 3.

Drain flow from the pilot valve is at the "Y" port of the main body and must be piped directly to tank. Maximum drain line pressure is 1500 PSI (102 Bar), 3000 PSI (207 Bar) optional. Any drain line back pressure is additive to the pilot pressure requirement.

Internal: Drain flow from the pilot valve is internally connected to the main valve tank port. Tank and drain pressure are then identical so tank line pressure should not exceed 1500 PSI (102 Bar), 3000 PSI (207 Bar) optional. Any tank line back pressure is also additive to the pilot pressure requirement. If flow surges (a cause of pressure surges) are anticipated in the tank line, an external drain variation is recommended. The "Y" port in the subplate must be plugged when using an internal drain.

D81V* Flow Paths

Style Code	Description	No Solenoid/Operator Energized	Solenoid/Operator A Energized	Solenoid/Operator B Energized
B	Spring Offset	P→A and B→T	—	P→B and A→T
C	Spring Centered	Centered	P→A and B→T	P→B and A→T
D	Detented	Last Position Held	P→A and B→T	P→B and A→T
E	Spring Centered	Centered	—	P→B and A→T
F†	Spring Offset, Shift to Center	P→A and B→T	—	Centered
H	Spring Offset	P→B and A→T	P→A and B→T	—
K	Spring Centered	Centered	P→A and B→T	—
M†	Spring Offset, Shift to Center	P→B and A→T	Centered	—

† D81VW only.

2502-A5.p65, dd

Series D8P

A

Tank and Drain Line Surges

If several valves are piped with a common tank or drain line, flow surges in the line may cause an unexpected spool shift. Detent style valves are most susceptible to this. Separate tank and drain lines should be piped in installations where line surges are expected.

Loss of Pilot Pressure

Should a loss of pilot pressure occur, spring offset and spring centered valves will shift to the spring held position. No spring valves will stay in the last position held. If main hydraulic flow does simultaneously stop, machine actuators may continue to function in an undesirable manner or sequence.

Pilot Drain Characteristics

Pilot Pressure:

75 to 5000 PSI (5.1 to 350 Bar)



100 PSI (6.9 Bar) for spool configurations 2, 7, 8, 9 & 12

Direct pilot operated valves use the "X" and "Y" ports to supply pilot oil directly to the ends of the spool, providing spool shifting force. A block mounted on top of the valve body is internally cored to make the necessary connections. Thus when "X" is pressurized, "Y" is used as a drain; and when "Y" is pressurized, "X" becomes the drain.

Any back pressure in these lines when they are being used as a drain is additive to the pilot pressure requirement.

Internal Drain: On spring offset models, only the "X" port is pressurized, as the spring returns the spool to its at rest position. On these models, "Y" may be internally drained through the main tank passage in the valve.

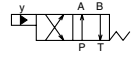
Flow Path/Pilot Pressure

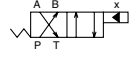
Style Code	Description	"X" & "Y" De-Pressurized	"X" Port Pressurized	"Y" Port Pressurized	Special Notes	Recommended Control Valve For Pilot Oil
B	Two Position Spring Offset	P→A, B→T	P→A, B→T	P→B, A→T	"X" Port may be pressurized to assist spring in returning spool to offset position (ext. only)	
C	Three Position Spring Centered	Center	P→A, B→T	P→B, A→T	Flow paths will be reversed on valves with tandem center (9) spools	
H	Two-Position Spring Offset	P→B, A→T	P→A, B→T	P→B, A→T	"Y" Port may be pressurized to assist spring in returning spool to offset position	

Subplate Mounting

NFPA D08, CETOP 8 & NG25



Recommended Mounting Surface

Surface must be flat within .102 mm (0.0004 inch) T.I.R and smooth within 812.8 micro-meters (32 micro-inch). Torque bolts to 135.6 Nm (100 ft-lbs).

For maximum valve reliability, adhere to the following installation information.

Mounting Position

Valve Type	Mounting Position
Detent (Solenoid)	Horizontal
Spring Offset	Unrestricted
Spring Centered	Unrestricted

Mounting Pattern

Inch equivalents for millimeter dimensions are shown in (**)

