

Application

Parker D61 series hydraulic directional control valves are high performance, solenoid controlled, pilot operated, two-stage, 4-way valves. They are available in 2 or 3 position styles and are manifold mounted. These valves conform to NFPA's D08/CETOP 8 mounting patterns.

Operation

Parker's D61 series directional valves consist of a five-chamber style main body, a case hardened sliding spool, and a pilot valve or pilot operators (hydraulic or pneumatic).

Features

- Easy access mounting bolts.
- 210 Bar (3000 PSI) pressure rating.
- Flows to 380 L/M (100 GPM) depending on spool.
- Choice of four operator styles.
- Rugged four land spools.
- Low pressure drop.
- Phosphate finish.

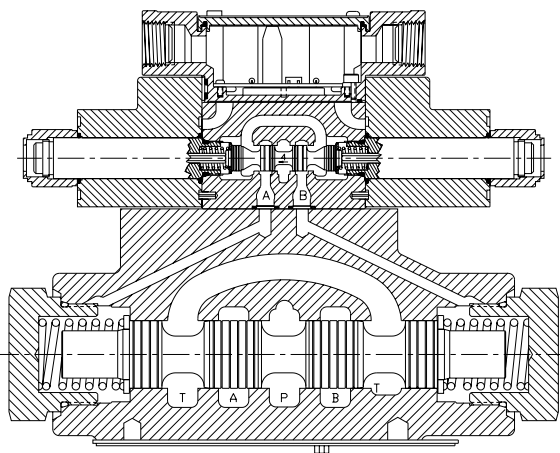

D61*W Solenoid Operated Conduit Box Style

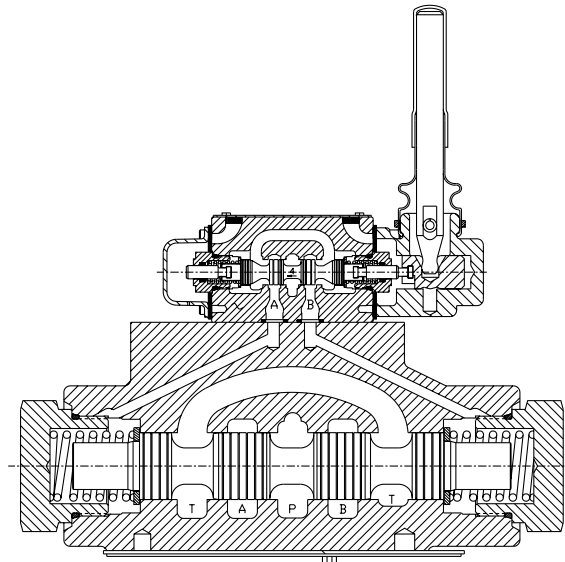

D61*L Lever Operated

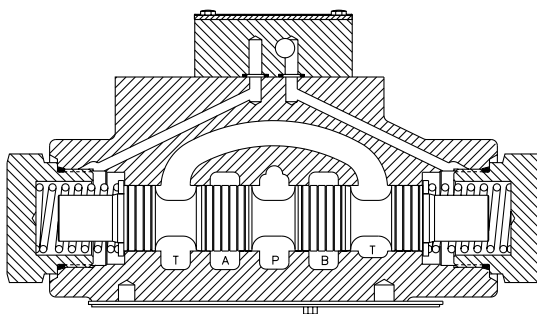

D6*P Oil Pilot Operated

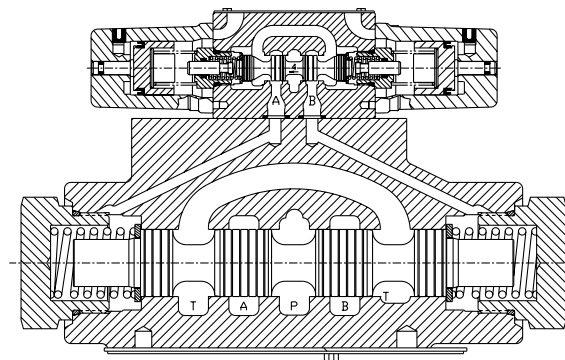

D61*A Air Pilot Operated

General Description

The D61VW is a five-chamber, pilot operated, solenoid controlled, directional control valve. It is available in 2 or 3-position styles. They are manifold or subplate mounted valves, which conform to NFPA's D08 /CETOP 8 mounting patterns.





Operation

Parker pilot operated valves are standard with low shock spools and pilot orifice. The orifice can be removed if a faster shift is required. It is recommended, however, that all systems operating above 2000 PSI use the standard valve to avoid severe shock.

Features

- Low pressure drop design
- Hardened spools provide long life
- Fast response option available
- Explosion proof availability
- Wide variety of voltages and electrical connection options
- No tools required for coil removal
- Repairable manual override for easy seal replacement

Specifications

Mounting Pattern	NFPA D08 CETOP 8, NG25
Maximum Operating Pressure	205 Bar (3000 PSI) Standard CSA  205 Bar (3000 PSI)
Maximum Tank Line Pressure	Internal Drain Model: 102 Bar (1500 PSI) Standard 205 Bar (3000 PSI) Optional External Drain Model: 205 Bar (3000 PSI) CSA  102 Bar (1500 PSI)
Maximum Drain Pressure	102 Bar (1500 PSI) Standard 205 Bar (3000 PSI) Optional CSA  102 Bar (1500 PSI)
Minimum Pilot Pressure	5.1 Bar* (75 PSI)
Maximum Pilot Pressure	205 Bar (3000 PSI) Standard CSA  205 Bar (3000 PSI)
Nominal Flow	189 Liters/Min (50 GPM)
Maximum Flow	See Quick Reference Data Chart

* 6.9 Bar (100 PSI) for spool configurations 002, 007, 008, 009 & 012.

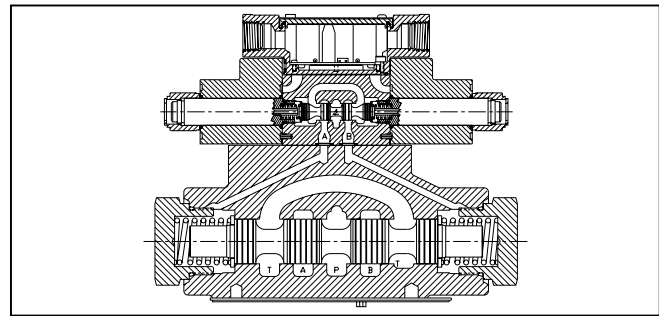
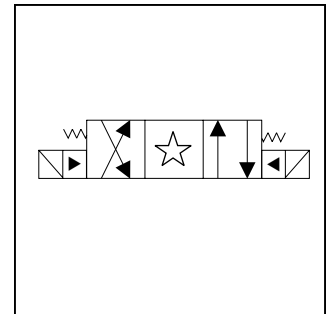
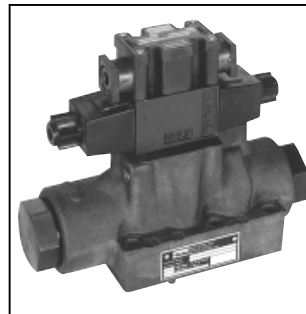

Response Time

Nominal response times (milliseconds) are measured at 205 Bar (3000 PSI) and 195 L/M (50 GPM) with various pilot pressures as indicated.

Solenoid Type	Pilot Pressure	Pull-In		Drop-Out	
		Std	Fast	Std	Fast
DC	500	130	100	80	80
	1000	90	90	80	80
	2000	80	80	80	80
AC	500	80	40	72	72
	1000	40	40	72	72
	2000	30	30	72	72

Because of the high drain line pressure transients generated during shifting, use of the fast response option is not recommended for pilot pressures exceeding 205 Bar (2000 PSI)



A

D							
Directional Control Valve	Basic Valve	Actuator#	Spool	Style	Pilot Supply and Drain	Seal	Solenoid Voltage

Code	Description
61V	NFPA D08, CETOP 8, DIN NG25 Low Flow, D03 Pilot

Code	Description
W	Solenoid, Wet Pin, Screw-in
HW	Reversed Wiring

Code	Description
N	Nitrile
V	Fluorocarbon

Code	Description
1	Internal Pilot, External Drain
2	External Pilot, External Drain
3*	Internal Pilot w/Check, External Drain
4#	Internal Pilot, Internal Drain
5	External Pilot, Internal Drain
6*	Internal Pilot w/Check Internal Drain

Code	Description
A	24/50 VAC
D	120 VDC
G	198 VDC
J	24 VDC
K	12 VDC
L	6 VDC
N	220/50 VAC
Q	100/60 VAC
R	24/60 VAC
T	240/60 - 220/50 VAC
U	98 VDC
Y	120/60 - 110/50 VAC
Z	250 VDC

Valve schematic symbols are per NFPA/ANSI standards, providing flow P to A when energizing solenoid A. Note operators reverse sides for #008 and #009 spools. See installation information for details. To configure per DIN standards (A coil over A port, B coil over B port) code valves as D61VHW***.

* #3 and #6 bodies cannot be converted to other styles. Other pilot versions cannot be converted to styles 3 and 6.
 # Not available with 002, 007, 008, 009 & 014 spools.

Code	Symbol	Code	Symbol
001		008*, 009**	
002		011	
003		012	
004		014	
005		015	
006		016	
007			

* 008 spool has closed crossover.
 ** 009 spool has open crossover.

Code	Description	Symbol
B *	2 position, spring offset P to A	
C	3 position, spring centered	
D *	2 position, detent, P to A and B to T	
E	2 position, spring centered and P to B	
F	2 position, spring offset P to A and centered	
H *	2 position, spring offset P to B	
K	2 position, spring centered and P to A	
M	2 position, spring offset P to B and centered	

* Available 001, 002 and 004, 011 and 012 spools only.

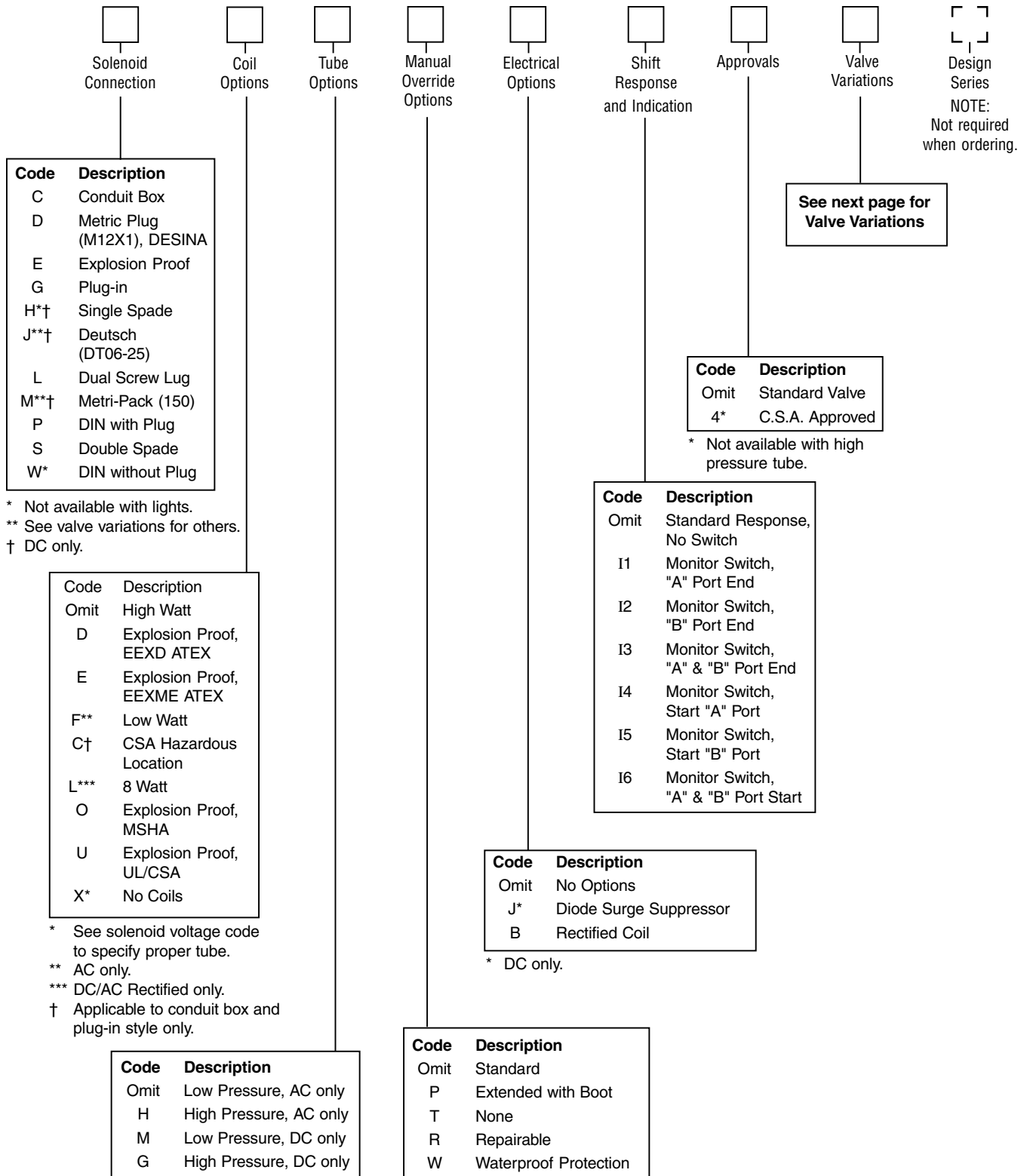

Valve Weight:
 Double Solenoid 12.1 kg (26.6 lbs.)
Standard Bolt Kit: BK227

Valve Variations

A

Code	Description	D31*W	D61*W	D81*W	D101*W
5	Signal Lights				
6	Manaplug – Brad Harrison Mini				
7A	Manaplug – Brad Harrison (12x1) Micro				
56	Manaplug (Mini) with Lights				
7B	Manaplug (Micro) with Lights (D1 only)				
20	Fast Response				
1A	Manaplug (Mini) Single Sol. 5-pin				
1B	Manaplug (Micro) Single Sol. 5-pin				
1C	Manaplug (Mini) Single Sol. 5-pin, with Lights				
1D	Manaplug (Micro) Single Sol. 5-pin, with Lights				
1E	Manaplug (Mini) Single Sol. 5-pin, with Stroke Adjust "A" & "B" End				
1F	Manaplug (Micro) Single Sol. 5-pin, with Stroke Adjust "A" & "B" End				
1G	Manaplug (Mini) Single Sol. 5-pin, with Stroke Adjust "A" & "B" End and Lights				
1H	Manaplug (Micro) Single Sol. 5-pin, with Stroke Adjust "A" & "B" End and Lights				
2B	On Board Bus – SDS				
2C	Manaplug (Micro) with Bus Wiring				
3A	Pilot Choke Meter Out				
3B	Pilot Choke Meter In				
3C	Pilot Pressure Reducer				
3D	Stroke Adjust "B" End				
3E	Stroke Adjust "A" End				
3F	Stroke Adjust "A" & "B" End				
3G	Pilot Choke Meter Out with Lights				
3H	Pilot Choke Meter In with Lights				
3J	Pilot Pressure Reducer with Lights				
3K	Pilot Choke Meter Out with Stroke Adjust "A" & "B" End				
3L	Pilot Choke Meter Out, Stroke Adjust "A" & "B" End with Lights and Manaplug and Brad Harrison Mini				
3M	Pilot Choke Meter Out, Pilot Pressure Reducer, Stroke Adjust "A" & "B" End				
4B	Protection Cap for Monitor Switch				
4D	Twist & Lock Override (Old 5426)				
4E	Push Manual Override (Old x5450)				

Quick Reference Data

Model	Spool Symbol	Maximum Flow, LPM (GPM) 207 Bar (3000 PSI) w/o Malfunction	Model	Spool Symbol	Maximum Flow, LPM (GPM) 207 Bar (3000 PSI) w/o Malfunction
D61V*001		390 (100)	D61V*008		312 (80)
D61V*002		312 (80)	D61V*009		312 (80)
D61V*003		390 (100)	D61V*011		390 (100)
D61V*004		390 (100)	D61V*012		137 (35)
D61V*005		390 (100)	D61V*014		195 (50)
D61V*006		390 (100)	D61V*015		390 (100)
D61V*007		195 (50)	D61V*016		390 (100)

See Universal Spool Chart for additional spools.

D61V* Series Pressure Drop Chart

The following chart provides the flow vs. pressure drop curve reference for the Series D61V valves by spool type.

VISCOSITY CORRECTION FACTOR							
Viscosity (SSU)	75	150	200	250	300	350	400
% of ΔP (Approx.)	93	111	119	126	132	137	141

Curves were generated using 100 SSU hydraulic oil. For any other viscosity, pressure drop will change per chart.

D61VW Pressure Drop Reference Chart -- Curve Number					
Spool No.	P-A	P-B	P-T	A-T	B-T
001	3	3	-	1	2
002	4	4	5	4	5
003	3	3	-	4	2
004	3	3	-	4	5
005	3	4	-	1	2
006	4	4	-	1	2
007	4	4	7	1	5
008/009	3	3	7	4	6
011	3	3	-	1	2
012	3	3	8	4	5
014	4	4	-	2	1
015	3	3	-	2	4
016	4	3	-	2	1

Performance Curves

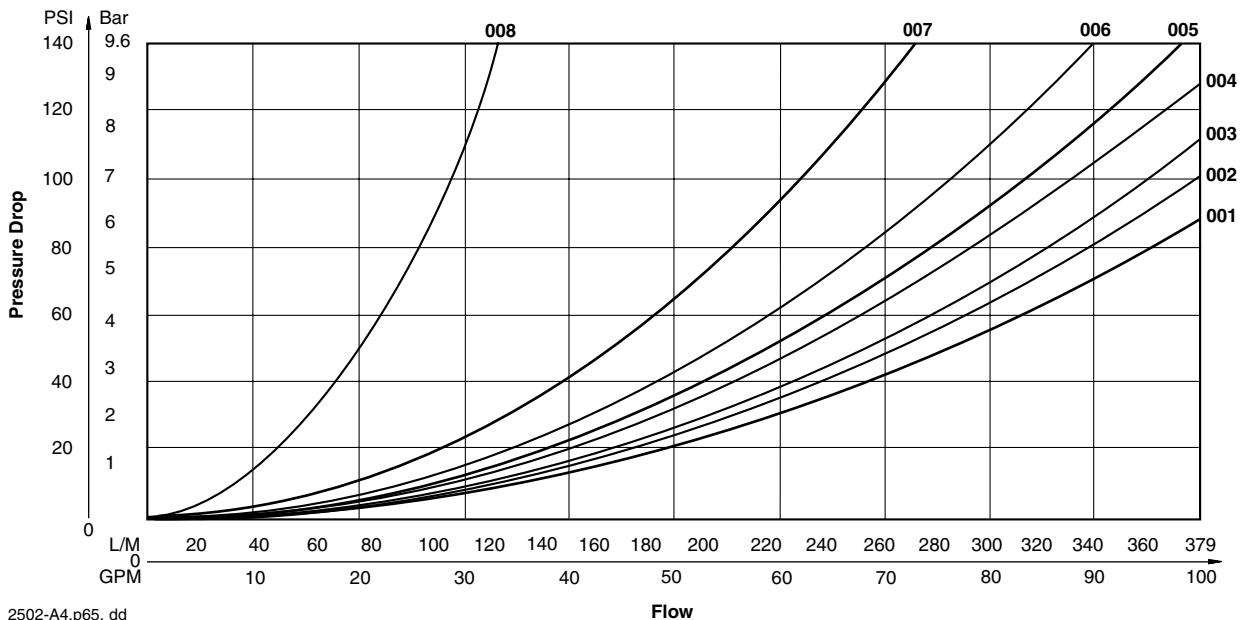

HVD = Hydraulic Valve Division HCD = Hydraulic Controls Division

		Closed Crossover	Open Crossover	Symmetrical	Standard	Spool Symbol					Spool: D1V*	Spool: D1V*	Spool: D3W	Spool: D31DW	Spool: D41	Spool: D41*W	Spool: D61VW	Spool: D81/D91	Spool: D101VW	Spool: D111
Spool Number						A		0		B	D1VW: D1VHW	D1V*: A/C/P/D/G/L	D3DW/ D31DW	Double Monitor Switch	HCD	Double Monitor Switch	HVD	HCD	HVD	HCD
001	x		x	x	x															
002		x		x	x															
003	x				x															
004	x			x	x															
005	x				x															
006	x			x	x															
007		x			x															
008	x			x	x															
009		x			x															
010	x				x															
011		x			x															
012		x	x		x															
014		x			x															
015	x				x															
016	x				x															
020B	x				x															
020D	x				x															
020H	x				x															
021	x				x															
022	x				x															
023		x																		
026B	x				x															
026H	x				x															
030B		x			x															
030D		x			x															
030H		x			x															
031	x																			
032	x																			
033																				
034	x																			
035	x																			
038																				
039																				
042	x			x																
043B																				
043H																				
044		x																		
044B		x																		
044H		x																		
047																				

Spools shown may be nonstandard. Please contact HVD for availability.

HVD = Hydraulic Valve Division HCD = Hydraulic Controls Division

Parker	Spool Number	Closed Crossover	Open Crossover	Symmetrical	Standard	Spool Symbol				Spool: D1V*	Spool: D1V*	Spool: D3W	Spool: D31DW	Spool: D41	Spool: D41*W	Spool: D61VW	Spool: D61/D91	Spool: D101VW	Spool: D111	
						A		0	B	D1VW: D1VHW	D1V*: A/C/P/ D/G/L	D3DW/ D31DW	Double Monitor Switch	HCD	Double Monitor Switch	HVD	HCD	HVD	HCD	
049B	x				x															
049H	x																			
051	x																			
054			x																	
055																				
056	x																			
058			x																	
059			x																	
061			x																	
062			x																	
065B																				
065H																				
066																				
067	x																			
068B	x																			
068H	x																			
069B	x																			
069H	x																			
070B																				
070H																				
071B	x																			
071H	x																			
073																				
074H																				
076	x				x															
078	x				x															
079																				
080																				
081	x			x	x															
081B																				
081H																				
082	x			x	x															
083B	x																			
083H	x																			
084																				
085																				
098																				
099																				
100																				
101B	x																			

Spools shown may be nonstandard. Please contact HVD for availability.



Solenoid Ratings

Insulation System	Class F
Allowable Deviation from rated voltage	-10% to +15% for DC and AC rectified coils -5% to +5% for AC Coils
Armature	Wet pin type
CSA File Number	LR60407
Environmental Capability	DC Solenoids are rated at NEMA 4 (IP67) or better when properly wired and installed. Contact HVD for AC coil applications.

Explosion Proof Solenoid Ratings*

U.L. & CSA (EU)	Class I, Div 1 & 2, Groups C & D Class II, Div 1 & 2, Groups E, F & G As defined by the NEC
M.S.H.A. (EO)	Complies with 30CFR, Part 18
ATEX (ED)	Complies with ATEX requirements for: Exd, Group IIB; EN50014: 1999+ Amds. 1 & 2, EN50018: 2000
CSA Hazardous Location	Class II, Groups E, F & G

* Allowable Voltage Deviation +/- 10%
 Note that AC coils are single frequency only.

Code		Voltage	In Rush Amps Amperage	In Rush Amps D1VW VA @ 3MM	Holding Amps D1VW	Watts D1VW	Resistance D1VW
Voltage Code	Power Code						
A		24/50 VAC, High Watt	7.00 Amps	168 VA	2.65 Amps	28 W	1.67 ohm(s)
D	L	120 VDC	N/A	N/A	0.09 Amps	10 W	1584.00 ohm(s)
			N/A	N/A	0.26 Amps	30 W	528.00 ohm(s)
E		24/60 VAC, High Watt	6.00 Amps	144 VA	1.85 Amps	20 W	1.67 ohm(s)
		24/50 VAC, High Watt	7.00 Amps	168 VA	2.65 Amps	28 W	1.67 ohm(s)
G	L	198 VDC	N/A	N/A	0.05 Amps	10 W	3920.40 ohm(s)
			N/A	N/A	0.15 Amps	30 W	1306.80 ohm(s)
J	L	24 VDC	N/A	N/A	0.44 Amps	10 W	51.89 ohm(s)
			N/A	N/A	1.32 Amps	30 W	17.27 ohm(s)
K	L	12 VDC	N/A	N/A	0.88 Amps	10 W	12.97 ohm(s)
			N/A	N/A	2.64 Amps	30 W	4.32 ohm(s)
L	L	6 VDC	N/A	N/A	1.67 Amps	10 W	3.59 ohm(s)
			N/A	N/A	5.00 Amps	30 W	1.20 ohm(s)
M	L	9 VDC	N/A	N/A	1.11 Amps	10 W	8.12 ohm(s)
			N/A	N/A	3.35 Amps	30 W	2.67 ohm(s)
P		110/50 VAC			0.38 Amps	19 W	135.00 ohm(s)
R		24/60 VAC, High Watt	8.00 Amps	192 VA	2.70 Amps	27 W	1.40 ohm(s)
	F	24/60 VAC, Low Watt	6.67 Amps	160 VA	2.20 Amps	23 W	1.52 ohm(s)
S	***Specials***	SEE BELOW					
T		240/60 VAC, High Watt	0.77 Amps	185 VA	0.26 Amps	25 W	134.50 ohm(s)
		220/50 VAC, High Watt	0.82 Amps	180 VA	0.31 Amps	27 W	134.50 ohm(s)
	F	240/60 VAC, Low Watt	0.70 Amps	168 VA	0.22 Amps	21 W	145.00 ohm(s)
	F	220/50 VAC, Low Watt	0.75 Amps	165 VA	0.26 Amps	23 W	145.00 ohm(s)
U	L	98 VDC	N/A	N/A	0.10 Amps	10 W	960.00 ohm(s)
X	L	16 VDC	N/A	N/A	0.63 Amps	10 W	25.60 ohm(s)
Y		120/60 VAC, High Watt	1.55 Amps	186 VA	0.49 Amps	25 W	33.70 ohm(s)
		110/50 VAC, High Watt	1.65 Amps	182 VA	0.58 Amps	27 W	33.70 ohm(s)
	F	120/60 VAC, Low Watt	1.40 Amps	168 VA	0.42 Amps	21 W	36.50 ohm(s)
	F	110/50 VAC, Low Watt	1.50 Amps	165 VA	0.50 Amps	23 W	36.50 ohm(s)
	L*B	120/60 VAC, 10 Watt	0.63 Amps	83 VA	0.18 Amps	10 W	75.00 ohm(s)
	L*B	110/50 VAC, 10 Watt	0.73 Amps	79 VA	0.20 Amps	10 W	75.00 ohm(s)
	*H	120/60 VAC, High Pressure	1.40 Amps	168 VA	0.50 Amps	26 W	36.50 ohm(s)
	*H	110/50 VAC, High Pressure	1.48 Amps	163 VA	0.60 Amps	28 W	36.50 ohm(s)
Z	L	250 VDC	N/A	N/A	0.04 Amps	10 W	6875.00 ohm(s)
			N/A	N/A	0.13 Amps	30 W	1889.64 ohm(s)
Specials	S	Other voltages/frequencies may be available Contact HVD for more information					
Explosion Proof Solenoids							
R		24/60 VAC	7.63 Amps	183 VA	2.85 Amps	27 W	1.99 ohm(s)
T		240/60 VAC	0.76 Amps	183 VA	0.29 Amps	27 W	1.34 ohm(s)
N		220/50 VAC	0.77 Amps	169 VA	0.31 Amps	27 W	1.38 ohm(s)
Y		120/60 VAC	1.60 Amps	192 VA	0.58 Amps	27 W	33.50 ohm(s)
P		110/50 VAC	1.47 Amps	162 VA	0.57 Amps	27 W	34.70 ohm(s)
Q		100/60 VAC	1.90 Amps	192 VA	0.70 Amps	27 W	38.60 ohm(s)
K		12 VDC	N/A	N/A	2.75 Amps	33 W	4.36 ohm(s)
J		24 VDC	N/A	N/A	1.38 Amps	33 W	17.33 ohm(s)
D		120 VDC	N/A	N/A	0.28 Amps	33 W	420.92 ohm(s)
Z		250 VDC	N/A	N/A	0.13 Amps	33 W	1952.66 ohm(s)

Inch equivalents for millimeter dimensions are shown in (**)

Conduit Box, Double AC Solenoid

A

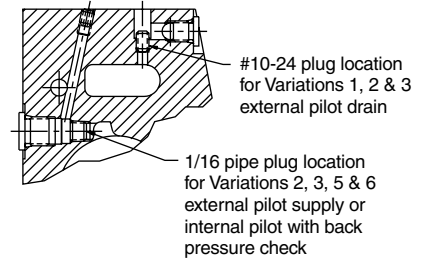
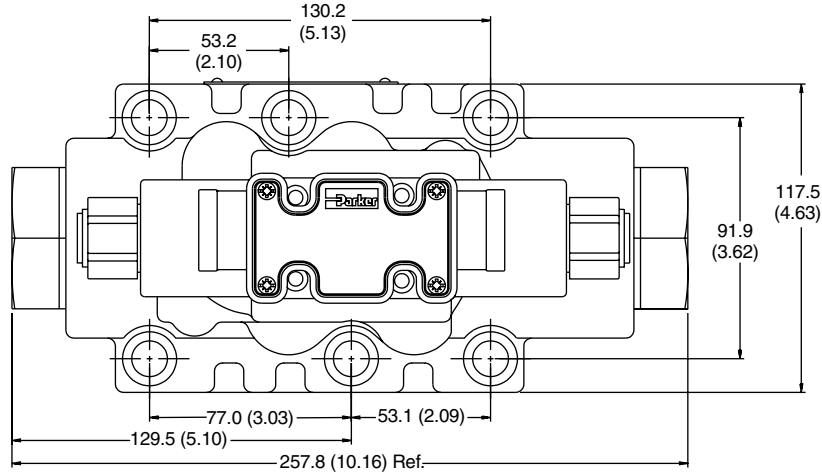

SECTION A-A

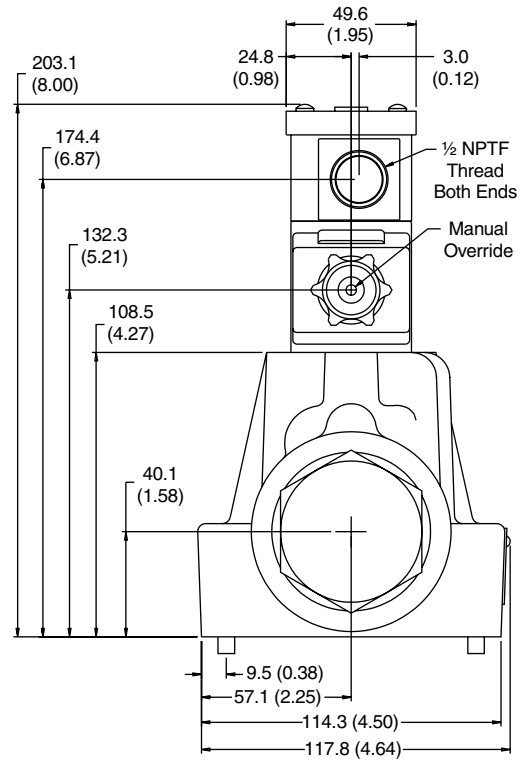
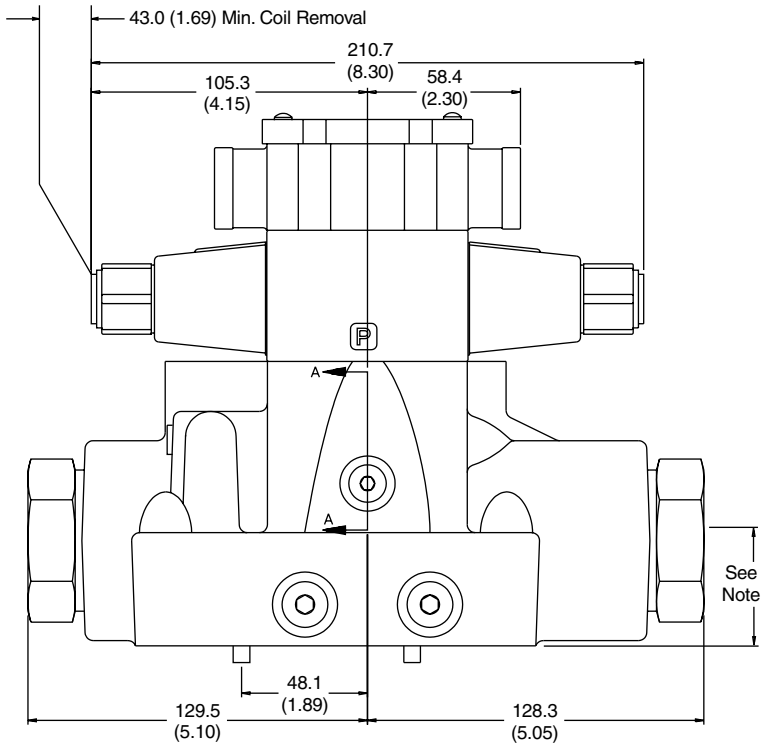

Note: 41.9mm (1.65") from bottom of bolt counterbore.



Inch equivalents for millimeter dimensions are shown in (**)



Conduit Box and Stroke Adjust, Double AC Solenoid

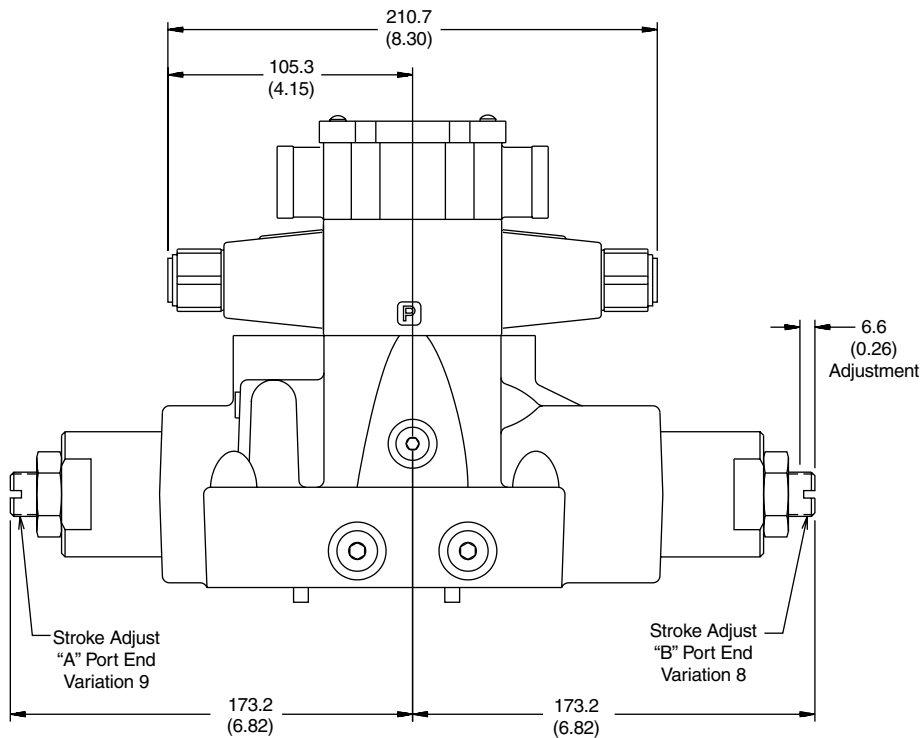

Conduit Box and Pilot Choke Control, Double AC Solenoid

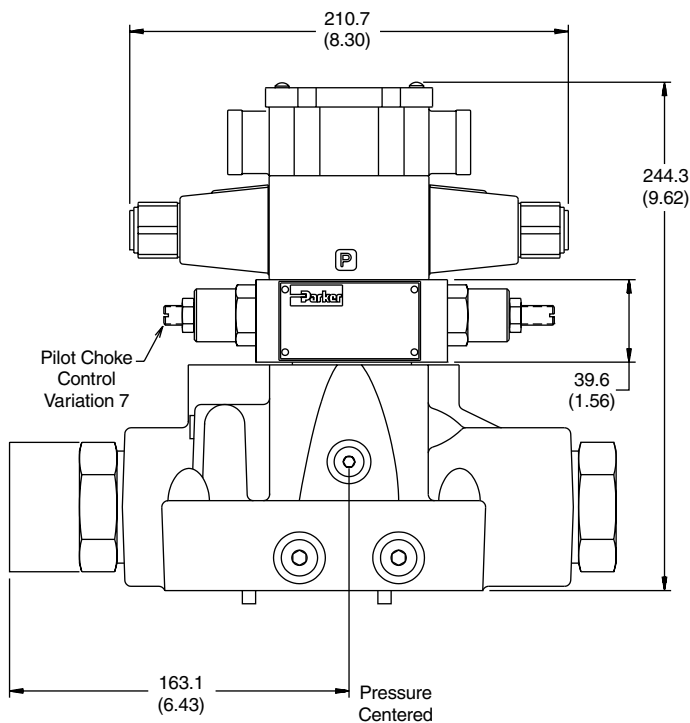

Conduit Box, Single AC Solenoid

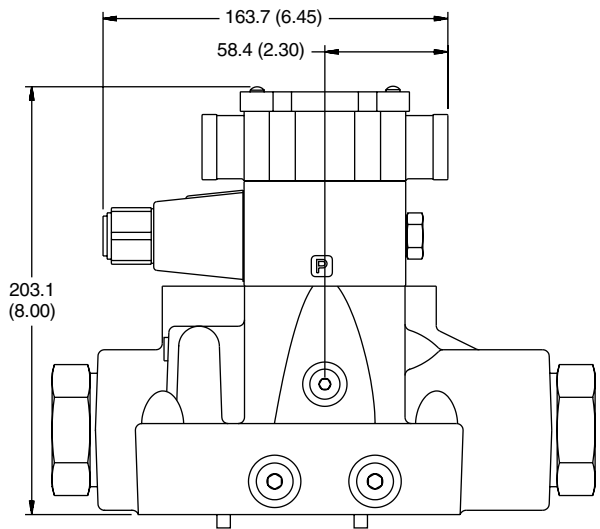

Inch equivalents for millimeter dimensions are shown in (**)

Plug-In Conduit Box, Double DC Solenoid

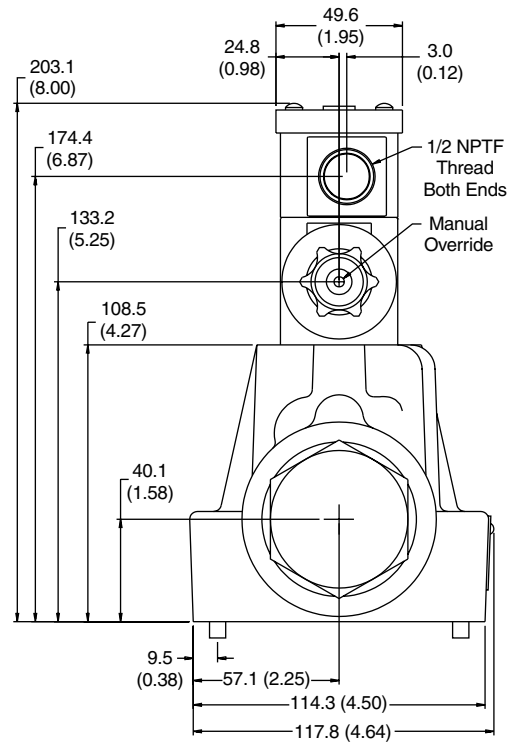
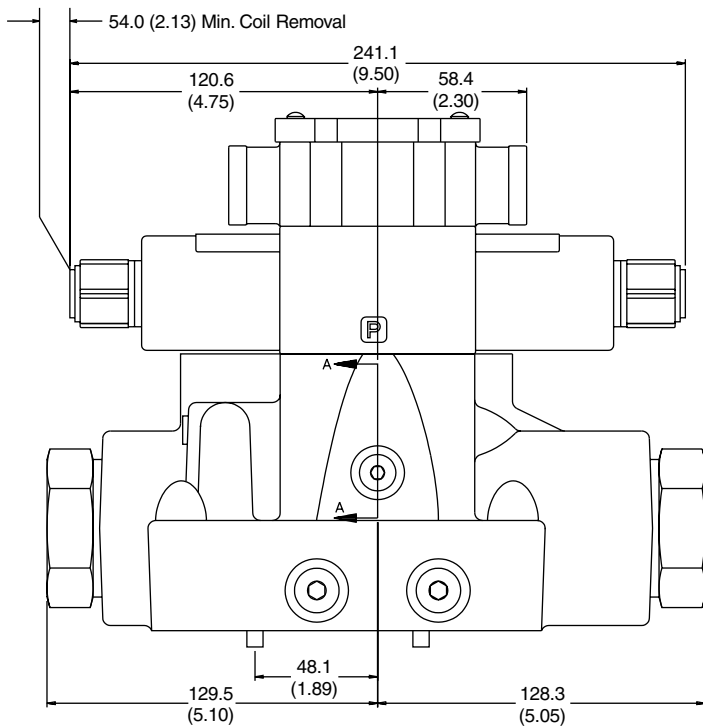
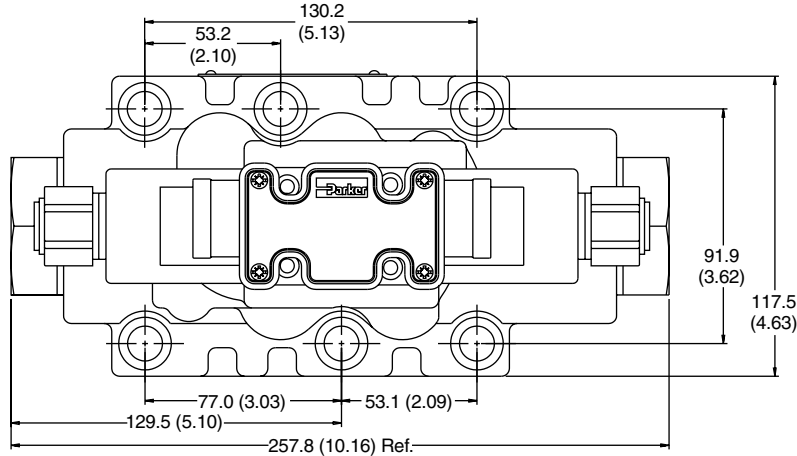

Inch equivalents for millimeter dimensions are shown in (**)



Hirschmann and Stroke Adjust, Double DC Solenoid

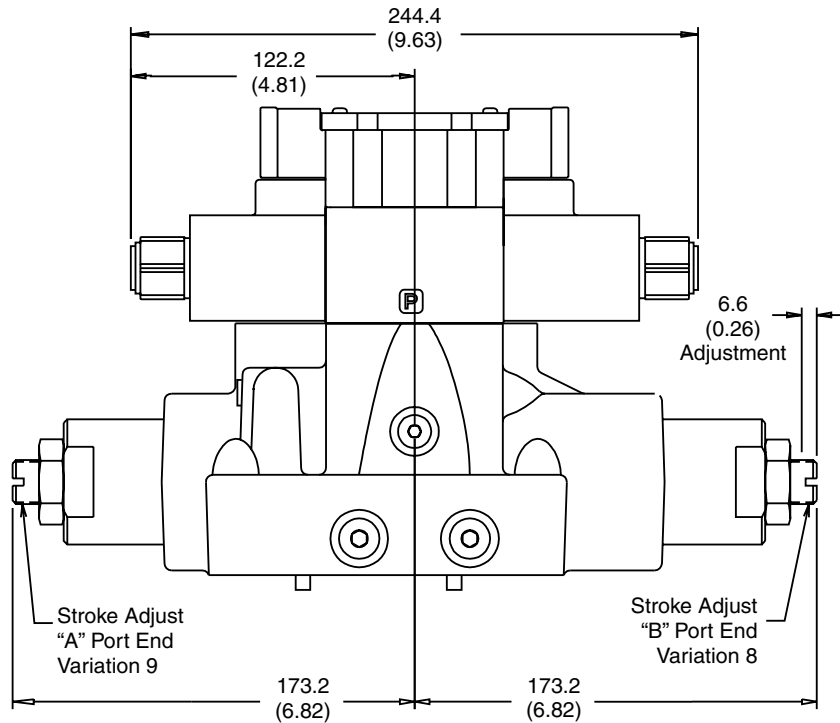

Hirschmann and Pilot Choke Control, Double DC Solenoid

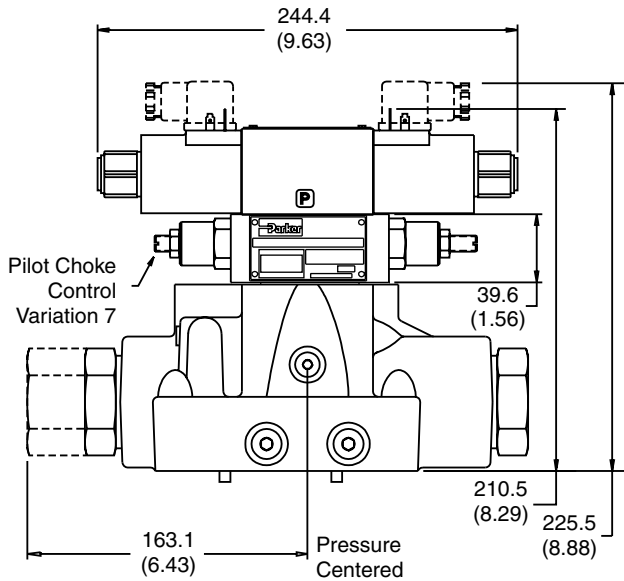

Conduit Box, Single DC Solenoid

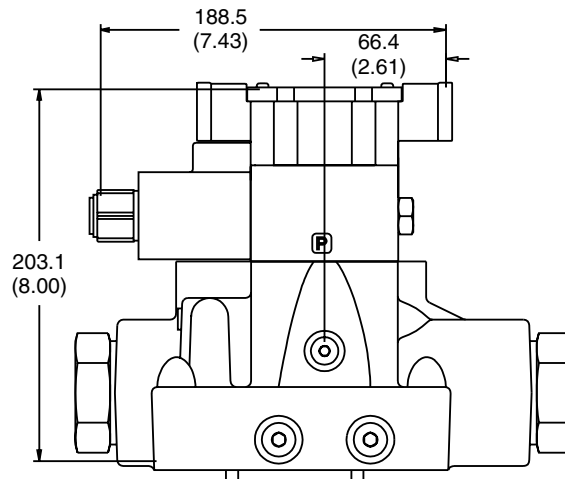

FOR MAXIMUM VALVE RELIABILITY, ADHERE TO THE FOLLOWING INSTALLATION INFORMATION.

The following is important installation information which applies to all directional control valves described in this catalog.

Mounting Position

Detent – Horizontal
Spring Offset – Unrestricted
Spring Centered – Unrestricted

Fluid Recommendations

Premium quality hydraulic oil with a viscosity range between 150-250 SSU (32-54 cst.) At 100°F (38°C) is recommended. The absolute operating viscosity range is from 80-1000 SSU (16-220 cst.). Oil should have maximum anti-wear properties and rust and oxidation treatment.

Fluids and Seals

Valves using synthetic, fire-resistant fluids require special seals. When phosphate esters or its blends are used, FLUOROCARBON seals are required. Water-glycol, water-in-oil emulsions and petroleum oil may be used with STANDARD seals.

Filtration

For maximum valve and system component life, the system should be protected from contamination at a level not to exceed 125 particles greater than 10 microns per milliliter of fluid (SAE class 4/ISO 16/13).

Silting

Silting can cause any sliding spool valve to stick and not spring return if held under pressure for long periods of time. The valve should be cycled periodically to prevent sticking.

Special Installations

Consult your Parker representative for any application requiring the following:

- Pressure above rating
- Fluid other than those specified
- Oil temperature above 160°F (71.1°C)
- Flow path other than normal.

Mounting Patterns

Series	NFPA	Size
D61V*, D6P	D08	3/4"

Torque Specifications

The recommended torque values for the bolts which mount the valve to the manifold or subplate are as follows: 135.6 Nm (100 ft-lbs)

Series D61VW, D61VA, D61VL

Tank and Drain Line Surges

If several valves are piped with a common tank or drain line, flow surges in the line may cause an unexpected spool shift. Detent style valves are most susceptible to this. Separate tank and drain lines should be piped in installations where line surges are expected.

Electrical Characteristics (Detented Spool)

Only a momentary energizing of the solenoid is necessary to shift and hold a detented spool. Minimum duration of the signal is 0.1 seconds for both AC and DC voltages. Spool position will be held provided the spool centerline is in a horizontal plane, and not shock or vibration is present to displace the spool.

Electrical Failure or Loss of Pilot Pressure (D61VA)

Should electric power fail or loss of pilot pressure occur, spring offset and spring centered valves will shift to the spring held position. Detented valves will stay in the last position held before power failure. If main flow does not fail or stop at the same time power fails, machine actuators may continue to function in an undesirable manner or sequence.

Pilot/Drain Characteristics

Pilot Pressure:

- 75 to 3000 PSI (5.1 to 207 Bar)
- 100 PSI (6.9 Bar) for spools 002, 007, 008, 009 & 012

External: An oil source sufficient to maintain minimum pilot pressure must be connected to the "X" port of the main body. When using the external pilot variation, a 1/16" pipe plug must be present in the main body pilot passage. (For details see Dimension pages.) This plug will be furnished in valves ordered with pilot code 2, 3, 5 or 6.

Internal: Flow is internally ported from the pressure port of the main valve body to the "P" port of the pilot valve. The pressure developed at the "P" port of the pilot valve must be 75 PSI (5.1 Bar) minimum at all times or 100 PSI (6.9 Bar) for spools 002, 007, 008, 009 & 012.

Integral Check: Valves using internal pilot and internal drain with an open center spool (spools 002, 008 & 009) can be ordered with an integral check valve in the pressure port of the main valve codes 3 & 6. Pilot oil will be internally ported from the upstream side of this check to the "P" port of the pilot valve, ensuring sufficient pilot pressure. A 1/16" pipe plug will be present in the main body. The "X" port in the subplate must be plugged when using the integral check.

Pilot Valve Drain:

Maximum pressure 1500 PSI (102 Bar), 3000 PSI (207 Bar) optional.

External: When using an external drain, a 10 x 24 x 0.31 long set screw must be present in the main body drain passage. (For details see Dimension pages.) This plug will be furnished in valves ordered with drain code 1, 2 or 3.

Drain flow from the pilot valve is at the "Y" port of the main body and must be piped directly to tank. Maximum drain line pressure is 1500 PSI (102 Bar), 3000 PSI (207 Bar) optional. Any drain line back pressure is additive to the pilot pressure requirement.

Internal: Drain flow from the pilot valve is internally connected to the main valve tank port. Tank and drain pressure are then identical so tank line pressure should not exceed 1500 PSI (102 Bar), 3000 PSI (207 Bar) optional. Any tank line back pressure is also additive to the pilot pressure requirement. If flow surges (a cause of pressure surges) are anticipated in the tank line, an external drain variation is recommended. The "Y" port in the subplate must be plugged when using an internal drain.

D61V* Flow Paths

Style Code	Description	No Solenoid/Operator Energized	Solenoid/Operator A Energized	Solenoid/Operator B Energized
B	Spring Offset	P→A and B→T	—	P→B and A→T
C	Spring Centered	Centered	P→A and B→T	P→B and A→T
D	Detented	Last Position Held	P→A and B→T	P→B and A→T
E	Spring Centered	Centered	—	P→B and A→T
F†	Spring Offset, Shift to Center	P→A and B→T	—	Centered
H	Spring Offset	P→B and A→T	P→A and B→T	—
K	Spring Centered	Centered	P→A and B→T	—
M†	Spring Offset, Shift to Center	P→B and A→T	Centered	—

† D61VW only.



Series D6P

Tank and Drain Line Surges

If several valves are piped with a common tank or drain line, flow surges in the line may cause an unexpected spool shift. Detent style valves are most susceptible to this. Separate tank and drain lines should be piped in installations where line surges are expected.

Loss of Pilot Pressure

Should a loss of pilot pressure occur, spring offset and spring centered valves will shift to the spring held position. No spring valves will stay in the last position held. If main hydraulic flow does simultaneously stop, machine actuators may continue to function in an undesirable manner or sequence.

Pilot Drain Characteristics

Pilot Pressure:

- 75 to 3000 PSI (5.1 to 207 Bar)
- 100 PSI (6.9 Bar) for spool configurations 2, 7, 8, 9 & 12

Direct pilot operated valves use the "X" and "Y" ports to supply pilot oil directly to the ends of the spool, providing spool shifting force. A block mounted on top of the valve body is internally cored to make the necessary connections. Thus when "X" is pressurized, "Y" is used as a drain; and when "Y" is pressurized, "X" becomes the drain.

Any back pressure in these lines when they are being used as a drain is additive to the pilot pressure requirement.

Internal Drain: On spring offset models, only the "X" port is pressurized, as the spring returns the spool to its at rest position. On these models, "Y" may be internally drained through the main tank passage in the valve.

Flow Path/Pilot Pressure

Style Code	Description	"X" & "Y" De-Pressurized	"X" Port Pressurized	"Y" Port Pressurized	Special Notes	Recommended Control Valve For Pilot Oil
B	Two Position Spring Offset	P→A, B→T	P→A, B→T	P→B, A→T	"X" Port may be pressurized to assist spring in returning spool to offset position (ext. only)	
C	Three Position Spring Centered	Center	P→A, B→T	P→B, A→T	Flow paths will be reversed on valves with tandem center (8) spools	
H	Two-Position Spring Offset	P→B, A→T	P→A, B→T	P→B, A→T	"Y" Port may be pressurized to assist spring in returning spool to offset position	

Subplate Mounting

NFPA D08, CETOP 8 & NG 25



Recommended Mounting Surface

Surface must be flat within .102 mm (0.0004 inch) T.I.R and smooth within 812.8 micro-meters (32 micro-inch). Torque bolts to 135.6 Nm (100 ft-lbs).

For maximum valve reliability, adhere to the following installation information.

Mounting Position

Valve Type	Mounting Position
Detent (Solenoid)	Horizontal
Spring Offset	Unrestricted
Spring Centered	Unrestricted

Mounting Pattern

Inch equivalents for millimeter dimensions are shown in (**)

