

**General Description**

Series 50\*SS low pressure, stainless steel ball valves provide total shut-off capability for services up to 138 Bar (2000 PSI).

**Operation**

A quarter turn of the handle is on or off. Ball Valves are not intended for use as a throttling valve. Attempting to use it in these applications may result in premature seal failure and/or inability to turn the valve handle.

**Features**

- Ball valve bodies are machined from CF-8M stainless steel castings, equivalent of 316 stainless steel which is suited for corrosive environments.
- Highly inert PTFE seats and seals provide resistance to chemical corrosion.
- Blowout proof stem design, 316 stainless ball and a special design handle enable increased turn and leverage for ease of opening and closing.
- Padlocking handle option provides lock-out capability where required.
- Style 502 allows panel mounting for installation flexibility.

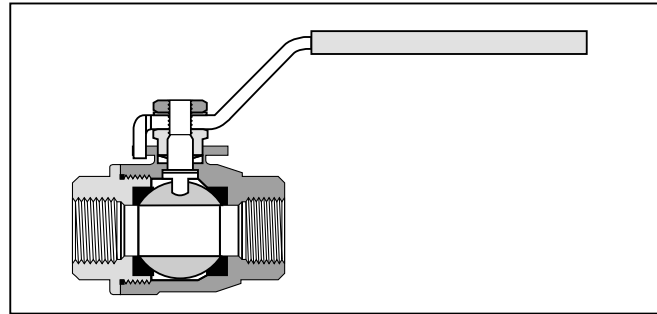
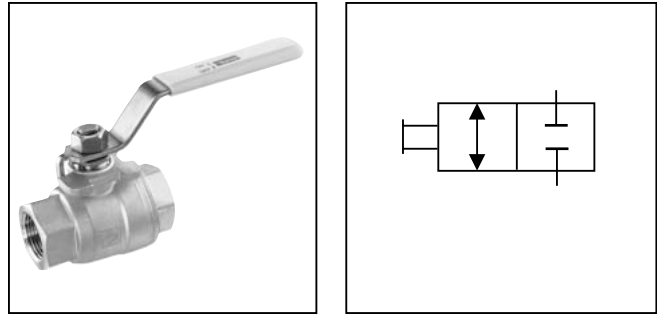

**Specifications**

<b>Working Pressure</b>	138 Bar (2000 PSI)
<b>Body Material</b>	CF-8M Stainless Steel 316SS Cast Equivalent
<b>Ball and Stem Material</b>	316 Stainless Steel

**Performance Curves**

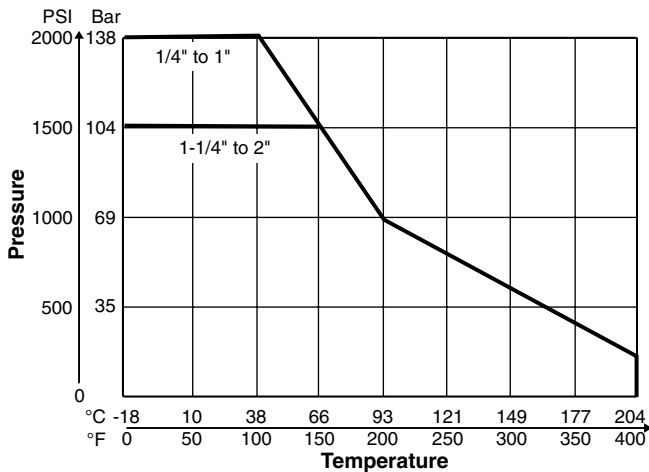

**Flow Data**

Type 501SS		Type 502SS	
Valve Size	C <sub>v</sub>	Valve Size	C <sub>v</sub>
1/4"	4.0	1/4"	4.0
3/8"	6.0	3/8"	6.0
1/2"	14.0	1/2"	14.0
3/4"	35.0	3/4"	35.0
1"	54.0	1"	54.0
		1-1/4"	74.0
		1-1/2"	120.0
		2"	226.0

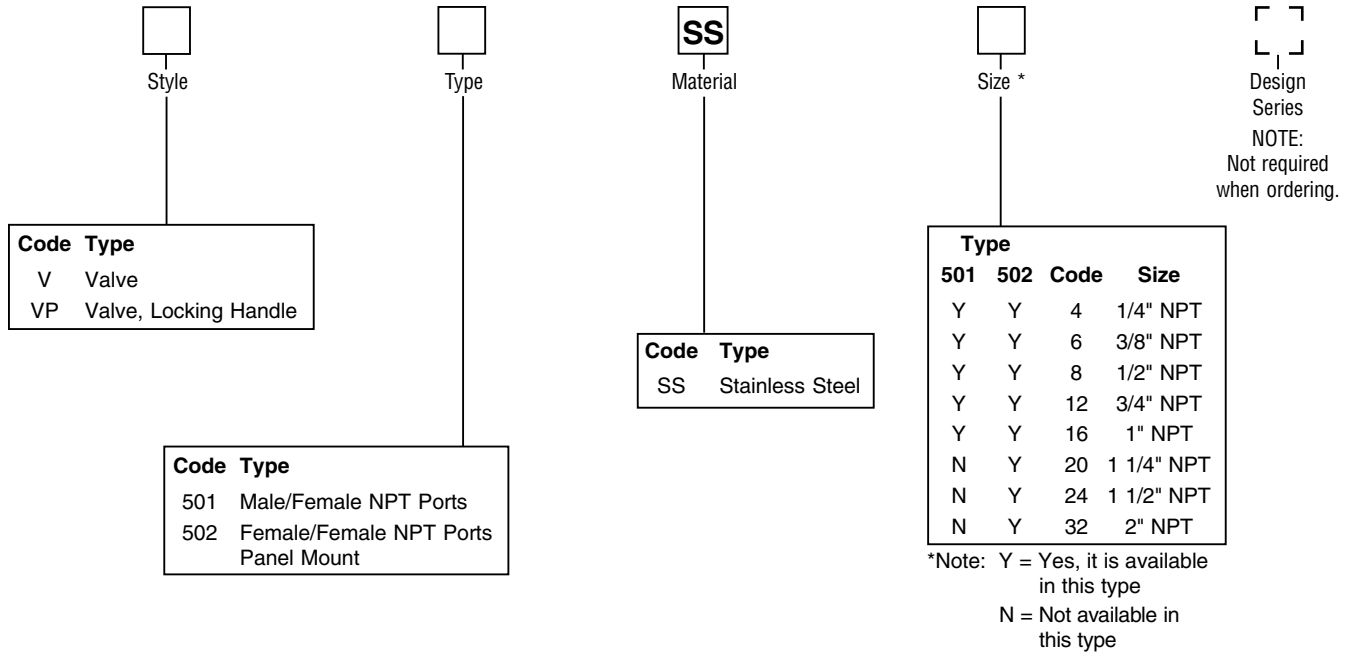

**Model V501SS**

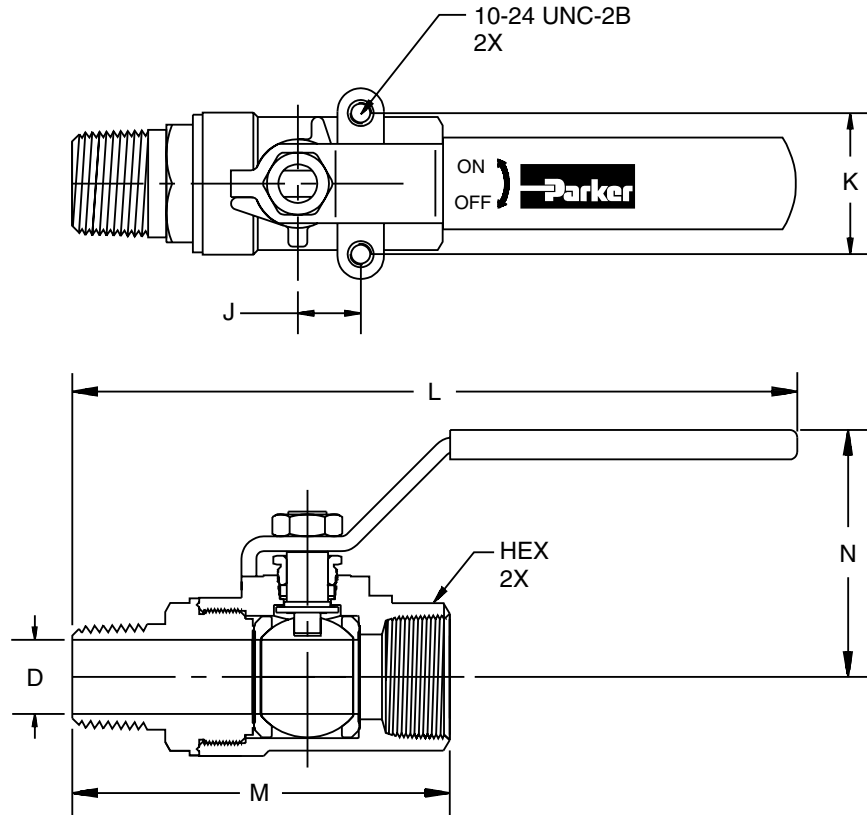

Part Number	Pipe Thread	Hex	Dimensions mm (in)					D Flow Ø
			J	K	L	M	N	
<b>Male-Female Pipe Ends V501SS</b>								
V501SS4	1/4"	15/16"	12.7 (.50)	28.4 (1.12)	142.2 (5.60)	67.3 (2.65)	50.0 (1.97)	7.1 (.280)
V501SS6	3/8"	15/16"	12.7 (.50)	28.4 (1.12)	142.2 (5.60)	67.3 (2.65)	50.0 (1.97)	9.5 (.375)
V501SS8	1/2"	1-1/16"	12.7 (.50)	28.4 (1.12)	148.6 (5.85)	77.5 (3.05)	50.8 (2.00)	12.7 (.500)
V501SS12	3/4"	1-3/8"	22.4 (.88)	34.8 (1.37)	184.7 (7.27)	97.8 (3.85)	64.8 (2.55)	18.3 (.720)
V501SS16	1"	1-5/8"	22.4 (.88)	34.8 (1.37)	190.0 (7.48)	108.0 (4.25)	68.1 (2.68)	23.9 (.940)

**Model V502SS and VP502SS**

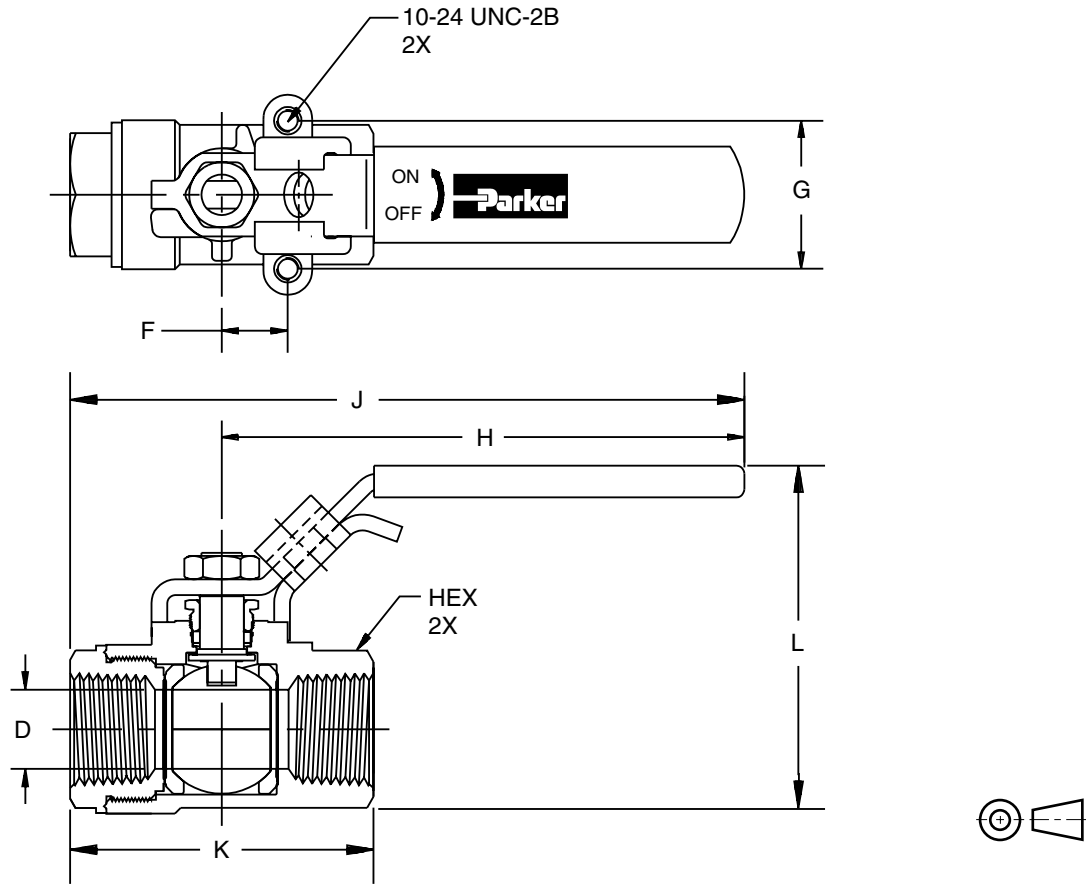

Part Number	Size	B/C Hex	F	Dimensions mm (in)					D Flow Ø	Panel Mount Thread
				G	H	J	K	L		
<b>Female to Female Panel Mount</b>										
V*502SS4	1/4"	15/16"	12.7 (0.50)	28.6 (1.13)	101.6 4.00	127.8 (5.03)	52.6 (2.07)	64.0 (2.52)	9.5 (0.38)	10-24 UNC
V*502SS6	3/8"	15/16"	12.7 (0.50)	28.6 (1.13)	101.6 4.00	127.8 (5.03)	52.6 (2.07)	64.0 (2.52)	9.5 (0.38)	10-24 UNC
V*502SS8	1/2"	1-1/16"	12.7 (0.50)	28.6 (1.13)	101.6 4.00	130.3 (5.13)	57.7 (2.27)	67.3 (2.65)	12.7 (0.50)	10-24 UNC
V*502SS12	3/4"	1-3/8"	22.2 (0.88)	34.9 (1.38)	127.0 (5.00)	169.4 (6.67)	85.1 (3.35)	87.9 (3.46)	20.1 (0.79)	10-24 UNC
V*502SS16	1"	1-5/8"	22.2 (0.88)	34.9 (1.38)	127.0 (5.00)	172.0 (6.77)	89.9 (3.54)	95.0 (3.74)	25.4 (1.00)	10-24 UNC
V*502SS20	1-1/4"	2"	25.4 (1.00)	38.1 (1.50)	177.8 (7.00)	228.6 (9.00)	101.6 (4.00)	115.6 (4.55)	31.8 (1.25)	1/4-20 UNC
V*502SS24	1-1/2"	2-3/8"	25.4 (1.00)	38.1 (1.50)	177.8 (7.00)	182.6 (7.19)	111.3 (4.38)	137.7 (5.42)	38.1 (1.50)	1/4-20 UNC
V*502SS32	2"	3"	25.4 (1.00)	38.1 (1.50)	177.8 (7.00)	247.7 9.75	139.7 (5.50)	144.3 (5.68)	50.8 (2.00)	1/4-20 UNC

Locking handle parts: For use with 5/16" diameter shank lock