

Lynch MANIFOLDS & VALVE PACKS

D07 Standard Flow Parallel Circuit Manifold

(See Page 1.99.01 for Relief Cartridges)

1

BAR MANIFOLDS

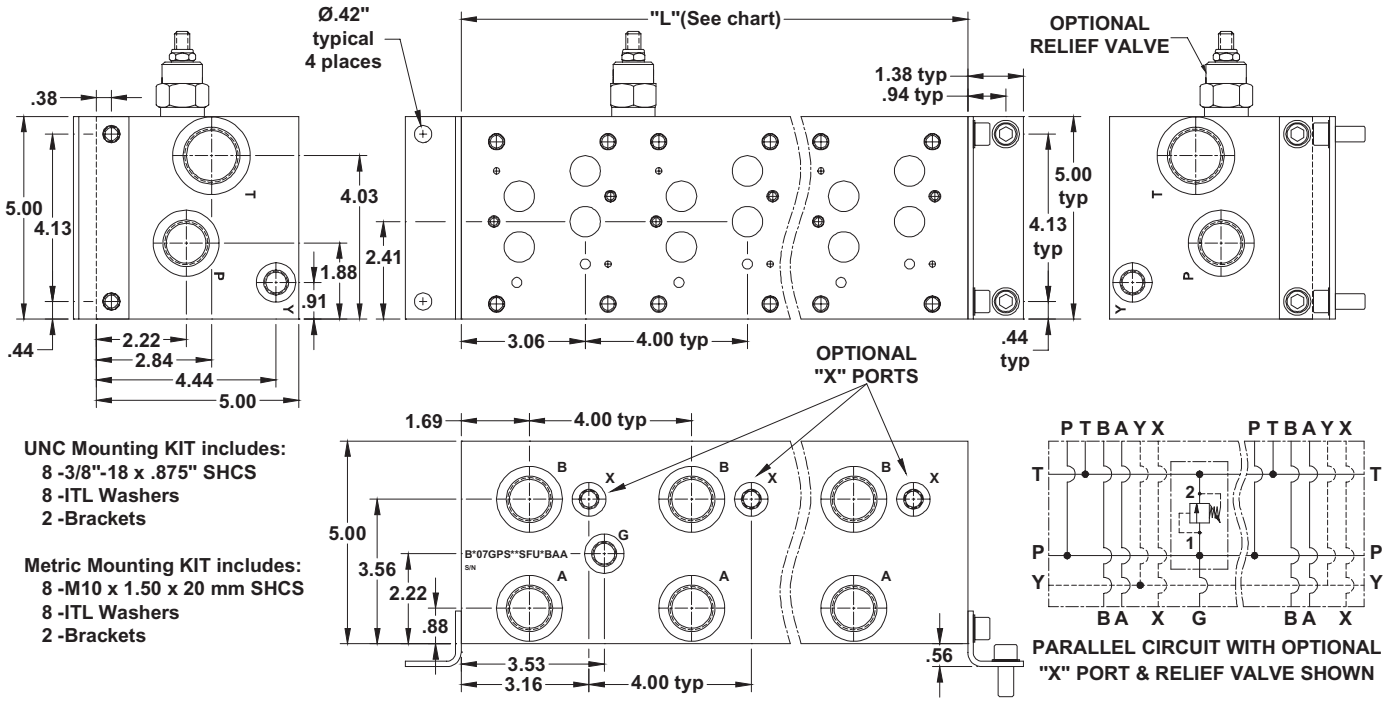

- UNC Mounting KIT includes:**
 8 - 3/8"-18 x .875" SHCS
 8 - ITL Washers
 2 - Brackets
- Metric Mounting KIT includes:**
 8 - M10 x 1.50 x 20 mm SHCS
 8 - ITL Washers
 2 - Brackets

No. of Stations	1	2	3	4	5	6	7	8
Dim. "L", 4.00" spacing	4.50	8.50	12.50	16.50	20.50	24.50	28.50	32.50
est. weight in lb.- alum	9	16	24	31	38	45	52	60
est. weight in lb.- iron	23	42	62	81	101	120	140	159

- Notes:**
- 1) Isolations on P & T available - See Page 5 for Codes
 - 2) Common X port option available - contact factory for P/N
 - 3) Larger relief cavities available - contact factory for P/N

PART NUMBER SYSTEM

Aluminum D07 with Common Y & SAE porting example: BA07GPS**SFUBAA

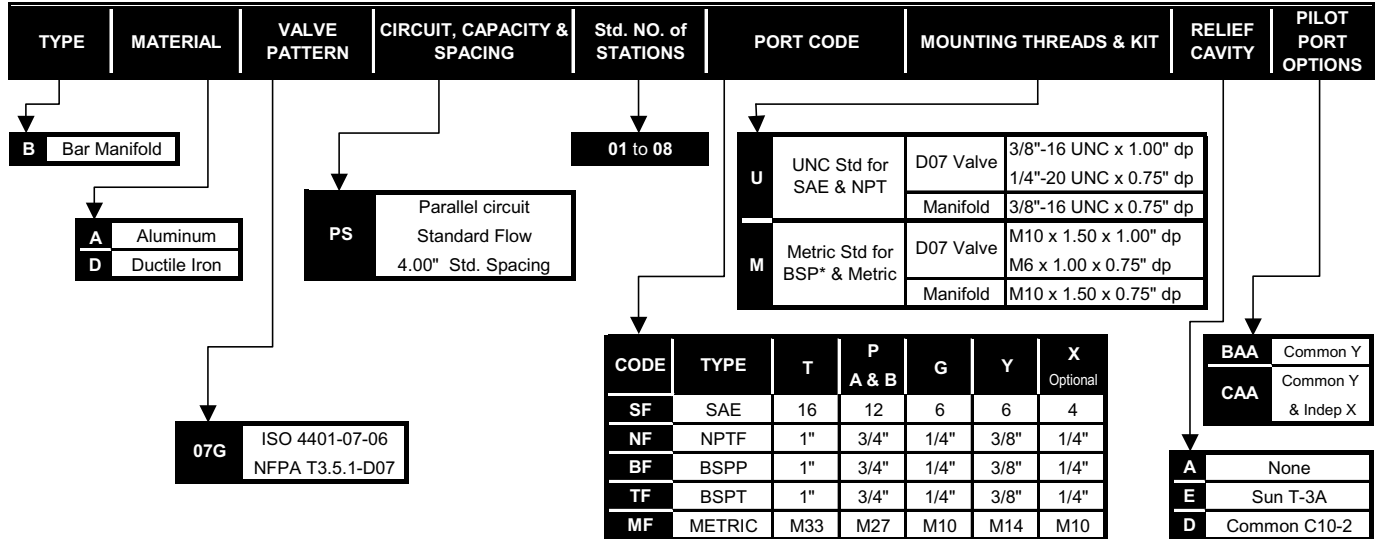

WE RESERVE THE RIGHT TO DISCONTINUE MODELS, OR CHANGE SPECIFICATIONS WITHOUT NOTICE OR INCURRING OBLIGATION

Lynch Products Can Be Modified to Suit Your Application



D07 High Flow Parallel Circuit Manifold

(See Page 1.99.01 for Relief Cartridges)

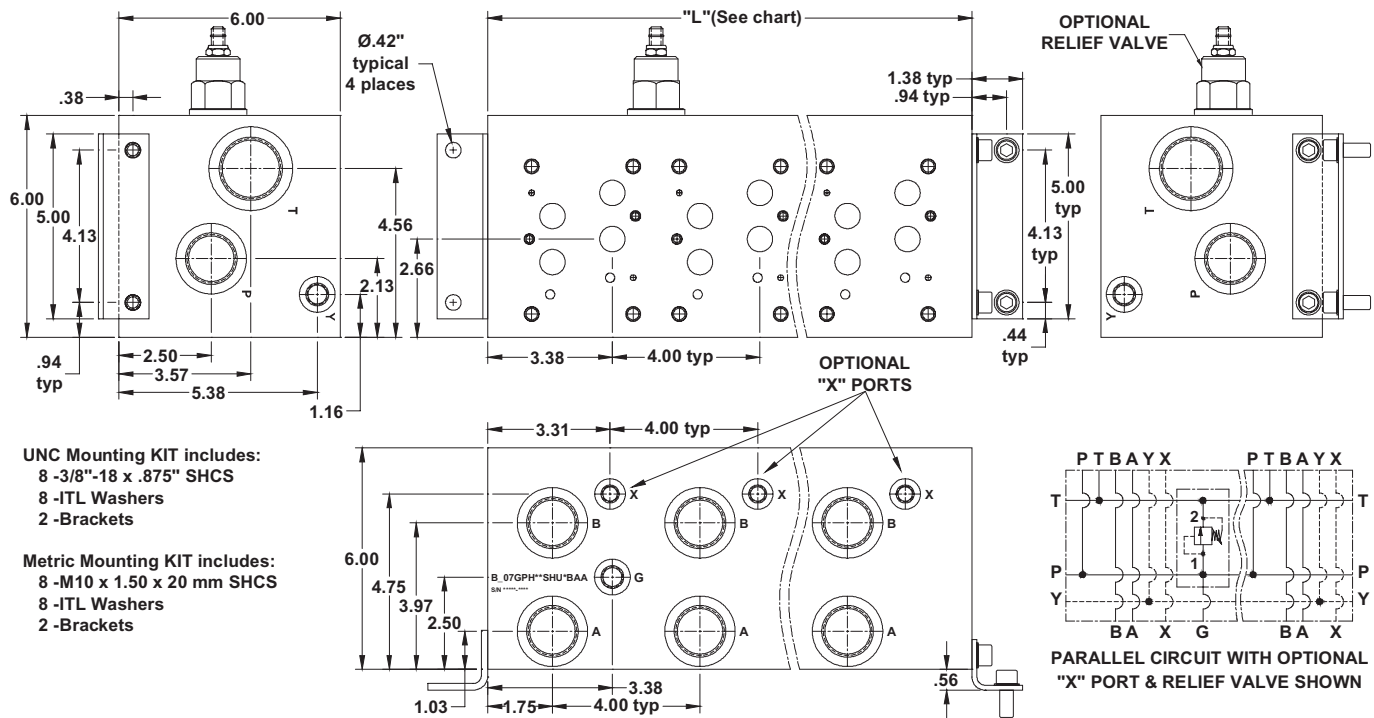

UNC Mounting KIT includes:
8 -3/8"-18 x .875" SHCS
8 -ITL Washers
2 -Brackets

Metric Mounting KIT includes:
8 -M10 x 1.50 x 20 mm SHCS
8 -ITL Washers
2 -Brackets

1

BAR MANIFOLDS

No. of Stations	1	2	3	4	5	6	7	8	9
Dim. "L" 4.00" spacing	5.13	9.13	13.13	17.13	21.13	25.13	29.13	33.13	37.13
est. weight in lb.- alum	18	31	44	56	69	82	95	108	121
est. weight in lb.- iron	46	81	116	151	186	221	256	291	326

Notes:

- 1) Isolations on P & T available - See Page 5 for Codes
- 2) Common X port available - contact factory for P/N
- 3) Wide Spacing Option - contact factory

SHADED AREA AVAILABLE ON SPECIAL ORDER ONLY

PART NUMBER SYSTEM

Aluminum D07 with Common Y & SAE porting example: BA07GPH**SHUABAA

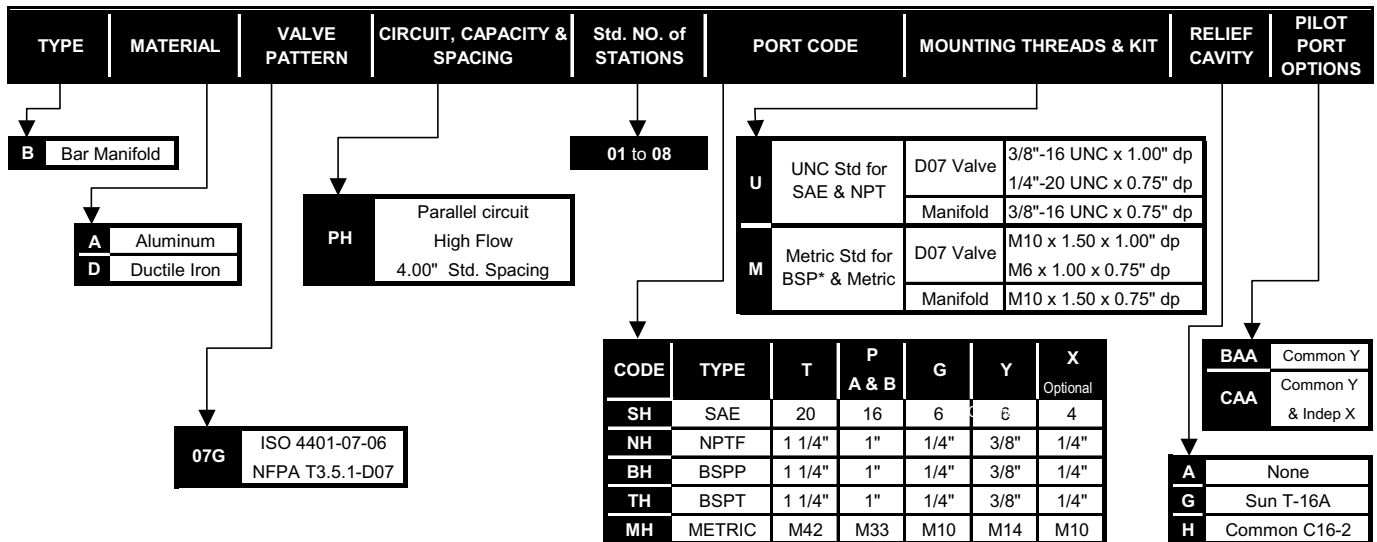

WE RESERVE THE RIGHT TO DISCONTINUE MODELS, OR CHANGE SPECIFICATIONS WITHOUT NOTICE OR INCURRING OBLIGATION

Lynch Products Can Be Modified to Suit Your Application



Lynch MANIFOLDS & VALVE PACKS

D07 High Flow Parallel Circuit with Flange Ports

(See Page 1.99.01 for Relief Cartridges)

1

BAR MANIFOLDS

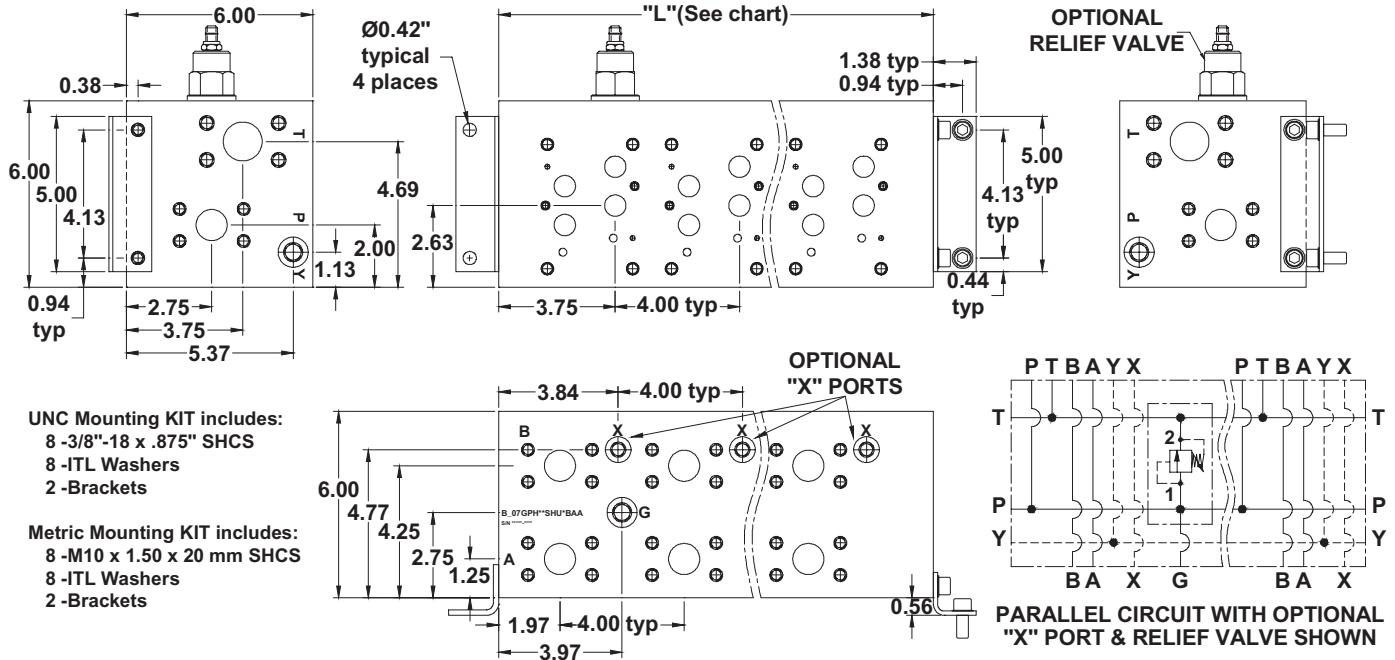

UNC Mounting KIT includes:

- 8 - 3/8"-18 x .875" SHCS
- 8 -ITL Washers
- 2 -Brackets

Metric Mounting KIT includes:

- 8 -M10 x 1.50 x 20 mm SHCS
- 8 -ITL Washers
- 2 -Brackets

No. of Stations	1	2	3	4	5	6	7	8	9
Dim. "L", 4.00" spacing	6.00	10.00	14.00	18.00	22.00	26.00	30.00	34.00	38.00
est. weight in lb.- alum	20	33	46	59	72	85	98	111	1239
est. weight in lb.- iron	53	103	123	158	193	355	263	298	333

Notes:

- 1) Isolations on P & T available - See Page 5 for Codes
- 2) Common X port option available - contact factory
- 3) Wide Spacing Option - contact factory

PART NUMBER SYSTEM

Aluminum D07 with Common Y & Flange porting example: BA07GPH**1HUABAA

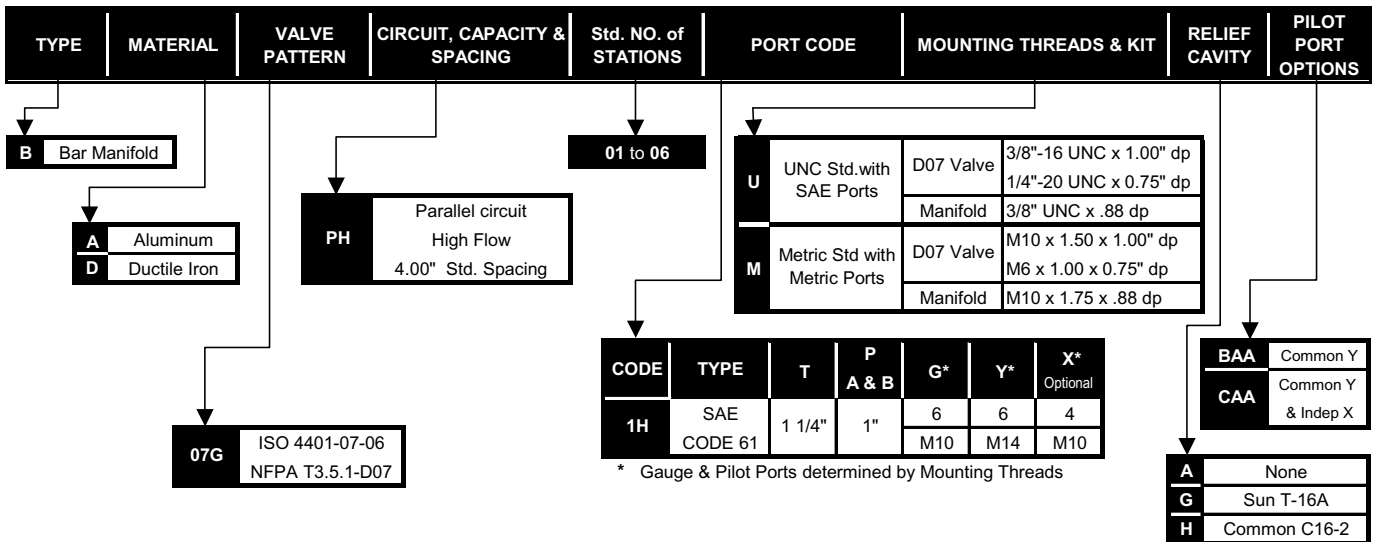

WE RESERVE THE RIGHT TO DISCONTINUE MODELS, OR CHANGE SPECIFICATIONS WITHOUT NOTICE OR INCURRING OBLIGATION

Lynch Products Can Be Modified to Suit Your Application



D07 Standard Flow Series Circuit Manifold

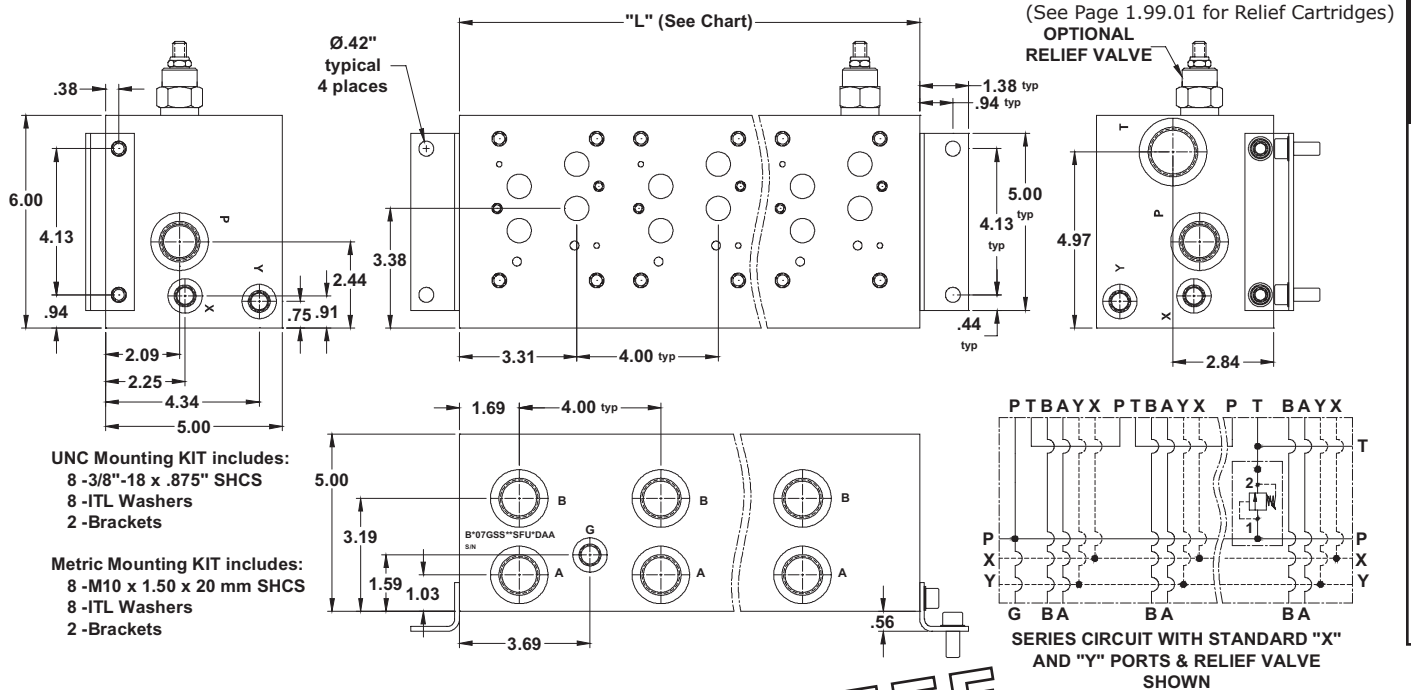

1
BAR
MANIFOLDS

RELIEF
OPTION
AVAILABLE

No. of Stations	2	3	4
Dim. "L", 4.00" spacing	9.00	13.00	17.00
est. weight in lb. - alum	30	43	56
est. weight in lb. - iron	80	115	150

PART NUMBER SYSTEM

Aluminum D07 with Common Y & X and SAE porting example: **BA07GSS**SFUADAA**

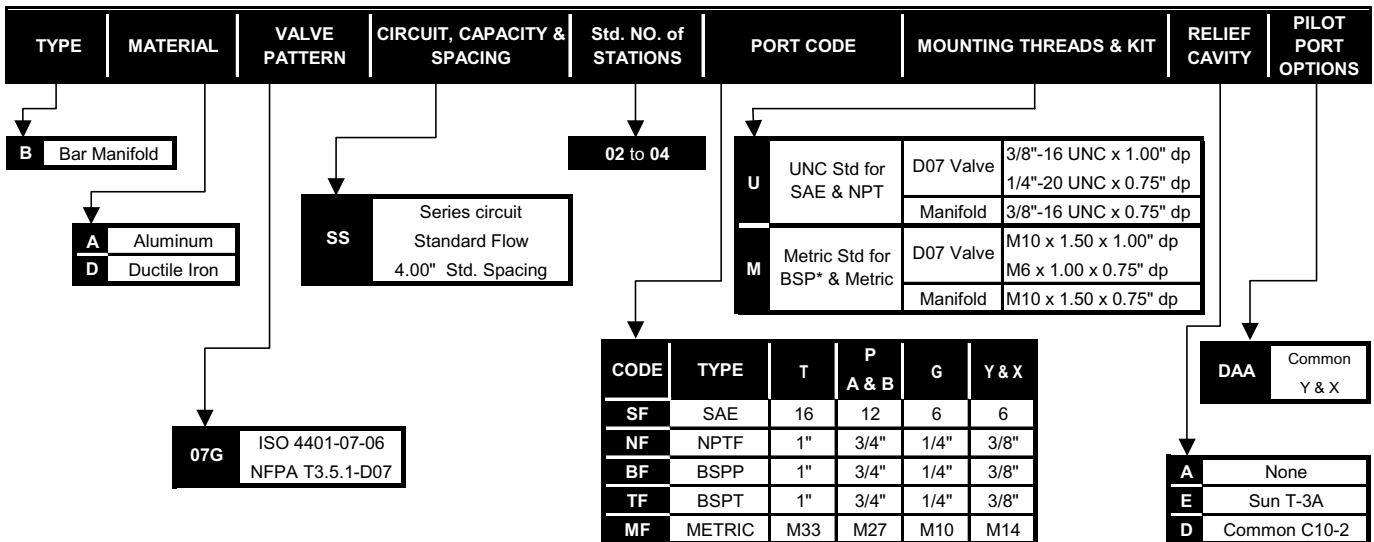

WE RESERVE THE RIGHT TO DISCONTINUE MODELS, OR CHANGE SPECIFICATIONS WITHOUT NOTICE OR INCURRING OBLIGATION

Lynch Products Can Be Modified to Suit Your Application

