

# Lynch MANIFOLDS & VALVE PACKS

## D02 Standard Flow Parallel Circuit Manifold

(See Page 1.99.01 for Relief Cartridges)

1  
BAR MANIFOLDS

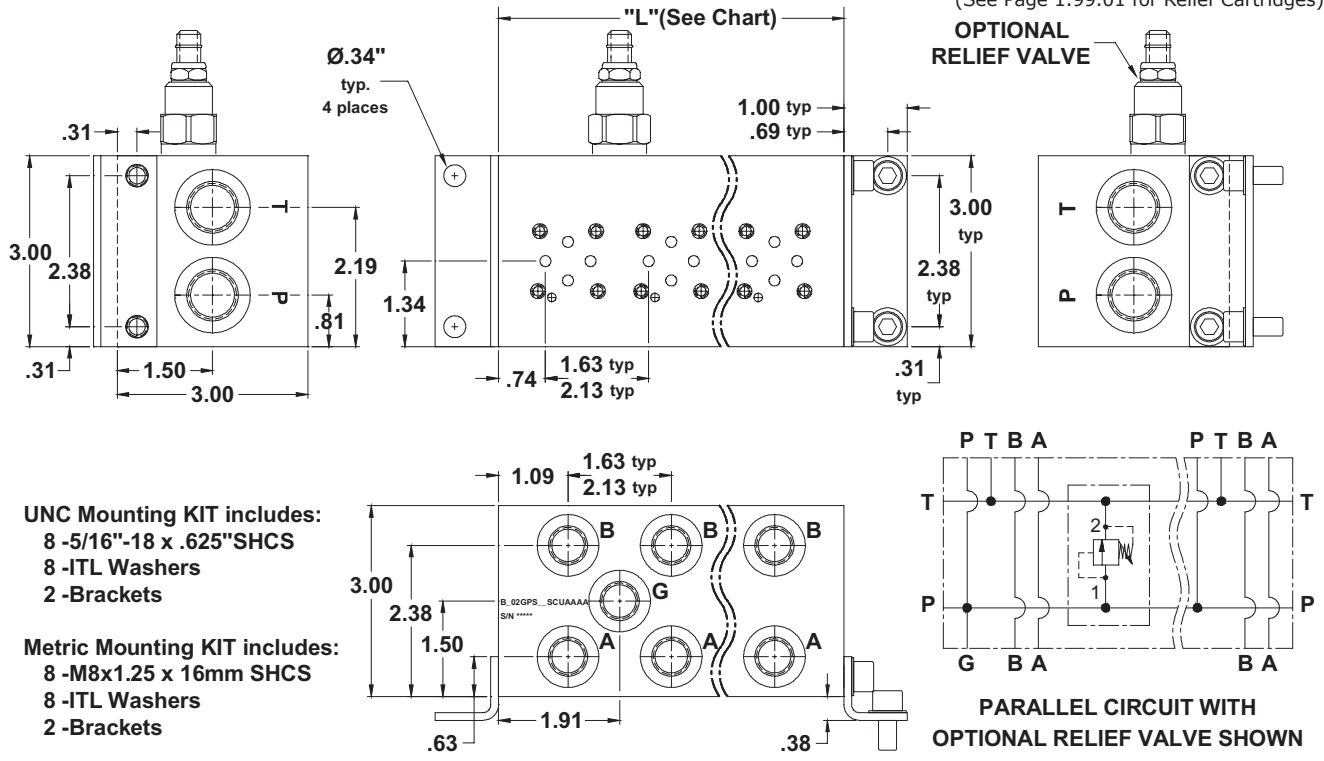

**UNC Mounting KIT includes:**  
8 -5/16"-18 x .625"SHCS  
8 -ITL Washers  
2-Brackets

**Metric Mounting KIT includes:**  
8 -M8x1.25 x 16mm SHCS  
8 -ITL Washers  
2-Brackets

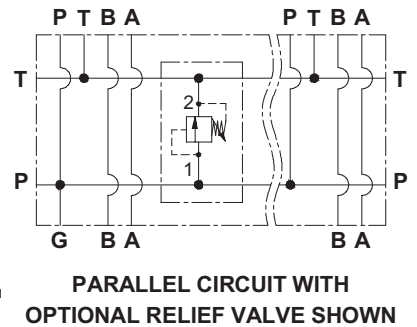

No. of Stations	1	1*	2	3	4	5	6	7	8	9	10	11	12	13	14	15	16
Dim. "L", 1.63" spacing	2.19	3.13	3.81	5.44	7.06	8.69	10.31	11.94	13.56	15.19	16.81	18.44	20.06	21.69	23.31	24.94	26.56
est. weight in lb.- alum	3	4	4	5	7	8	9	11	12	13	15	16	17	19	20	21	23
est. weight in lb.- iron	6	8	9	13	16	20	24	27	31	34	38	41	45	48	52	56	59
Dim. "L", 2.13" spacing	-	-	4.31	6.44	8.56	10.69	12.81	14.94	17.06	19.19	21.31	23.44	25.56	27.69	29.81	31.94	34.06
est. weight in lb.- alum	-	-	4	6	8	10	11	13	15	17	18	20	22	23	25	27	29
est. weight in lb.- iron	-	-	10	15	20	24	29	34	38	43	48	52	57	62	66	71	75

\* DIMENSIONS FOR 1 STATION WITH RELIEF CAVITY & GAUGE PORT  
NO GAUGE PORT SUPPLIED WITH SINGLE STATION MANIFOLD  
SHADED AREA AVAILABLE ON SPECIAL ORDER ONLY

### PART NUMBER SYSTEM

Aluminum D02 with 1.63" Spacing & SAE Porting example: BA02GPS\*\*SCUAAAA

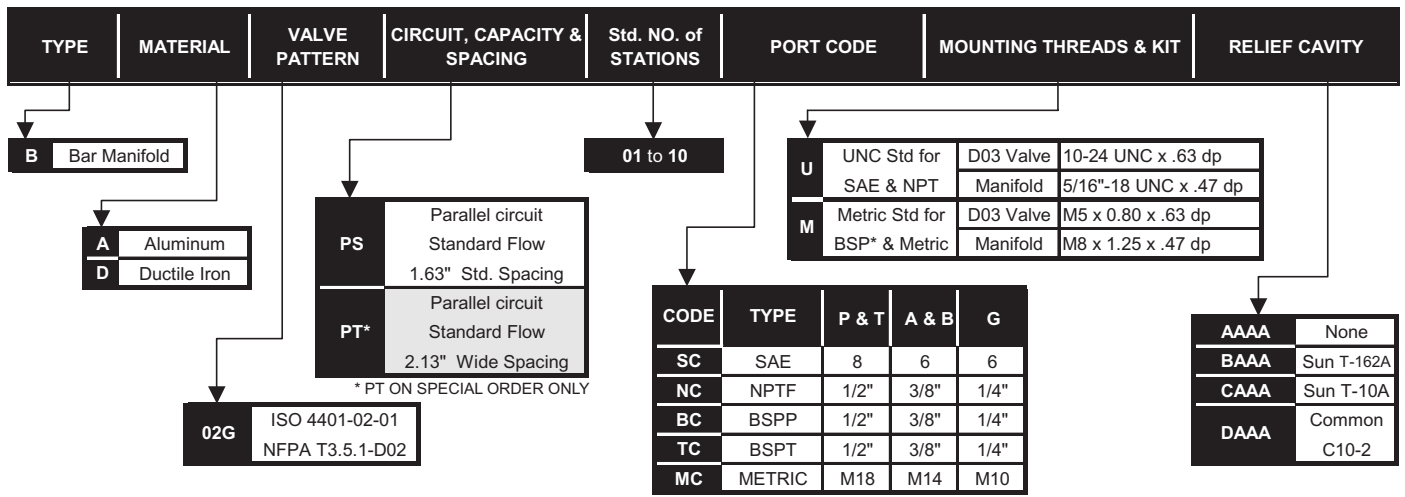

WE RESERVE THE RIGHT TO DISCONTINUE MODELS, OR CHANGE SPECIFICATIONS WITHOUT NOTICE OR INCURRING OBLIGATION

Lynch Products Can Be Modified to Suit Your Application



## D02 Standard Flow Series Circuit Manifold

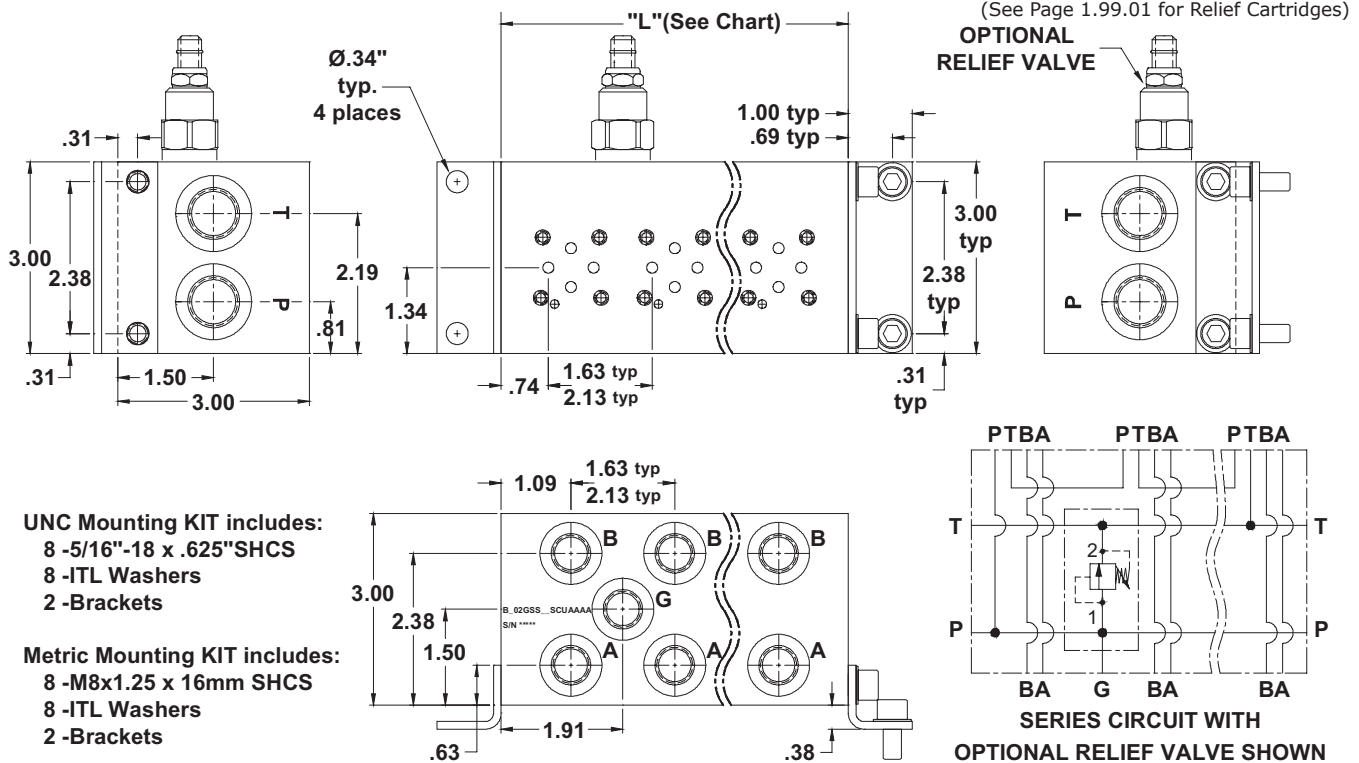

1

BAR  
MANIFOLDS

No. of Stations	2	3	4	5	6	7	8	9	10	11	12	13	14	15	16
Dim. "L", 1.63" spacing	3.81	5.44	7.06	8.69	10.31	11.94	13.56	15.19	16.81	18.44	20.06	21.69	23.31	24.94	26.56
est. weight in lb.- alum	4	5	7	8	9	11	12	13	15	16	17	19	20	21	23
est. weight in lb.- iron	9	13	16	20	24	27	31	34	38	41	45	48	52	56	59
Dim. "L", 2.13" spacing	4.31	6.44	8.56	10.69	12.81	14.94	17.06	19.19	21.31	23.44	25.56	27.69	29.81	31.94	34.06
est. weight in lb.- alum	4	6	8	10	11	13	15	17	18	20	22	23	25	27	29
est. weight in lb.- iron	10	15	20	24	29	34	38	43	48	52	57	62	66	71	75

SHADED AREA AVAILABLE ON SPECIAL ORDER ONLY

### PART NUMBER SYSTEM

Aluminum D02 with 1.63" Spacing & SAE Porting example: BA02GSS\*\*SCUAAAA

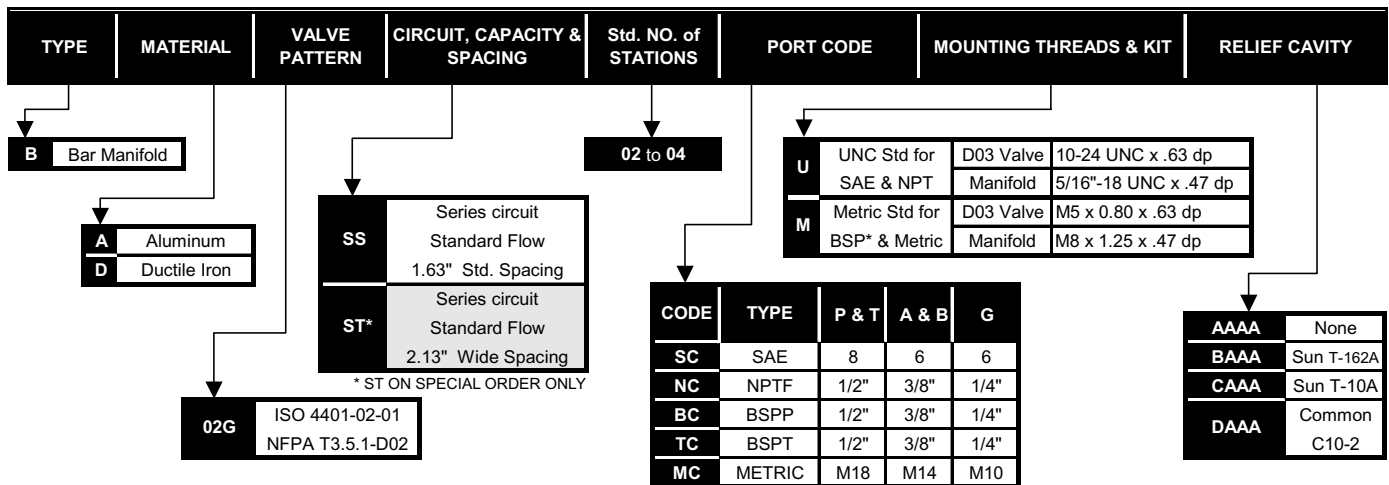

WE RESERVE THE RIGHT TO DISCONTINUE MODELS, OR CHANGE SPECIFICATIONS WITHOUT NOTICE OR INCURRING OBLIGATION

Lynch Products Can Be Modified to Suit Your Application

