



## D05 Tapping Plates with USA Pilot Ports

### P and T Port Tapping Plate

Tapping Plate interface seal kit is supplied. \*  
See page 124 for itemized list.  
\* Plug not supplied on metric ported parts.

### A and B Port Tapping Plate

Tapping Plate interface seal kit is supplied. \*  
See page 124 for itemized list.  
\* Plug not supplied on metric ported parts.

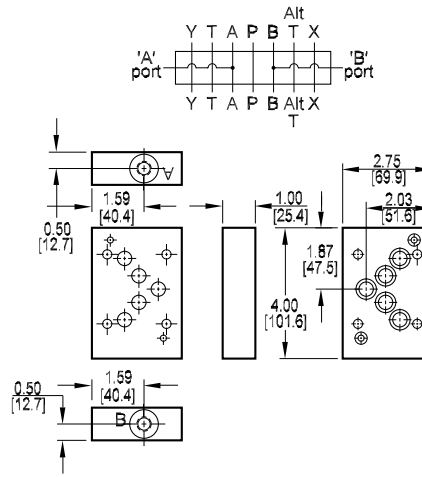
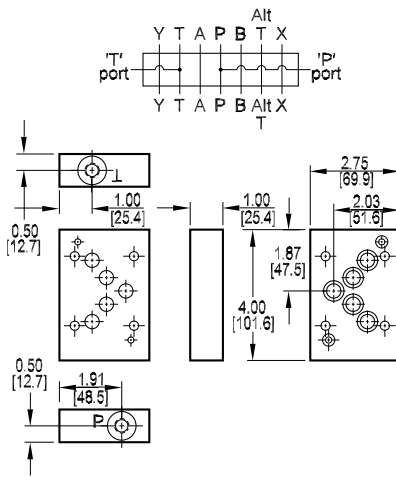

Specifications, descriptions, and dimensional data are subject to correction or change without notice or incurring obligation.

## 6 Ordering Information

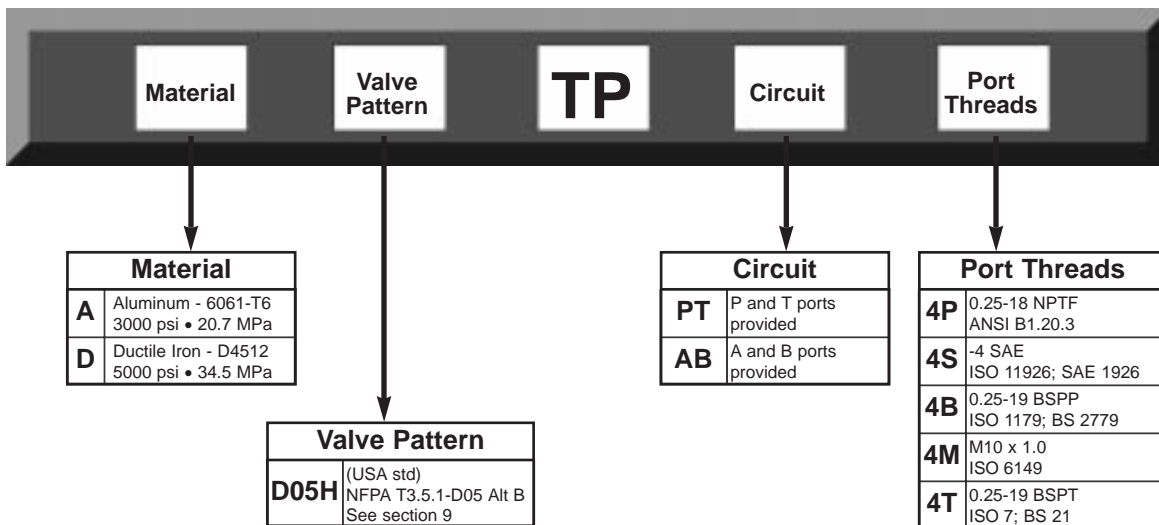



## D05 Tapping Plates with ISO Pilot Ports

### P and T Port Tapping Plate

Tapping Plate interface seal kit is supplied. \*  
See page 124 for itemized list.  
\* Plug not supplied on metric ported parts.

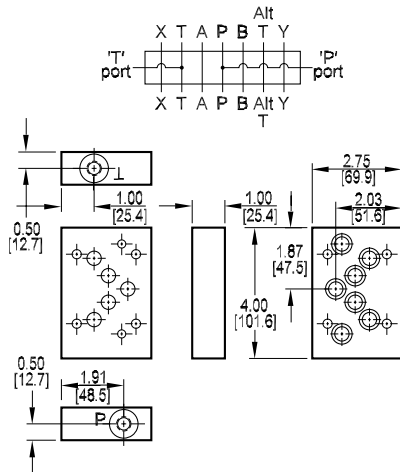

### A and B Port Tapping Plate

Tapping Plate interface seal kit is supplied. \*  
See page 124 for itemized list.  
\* Plug not supplied on metric ported parts.

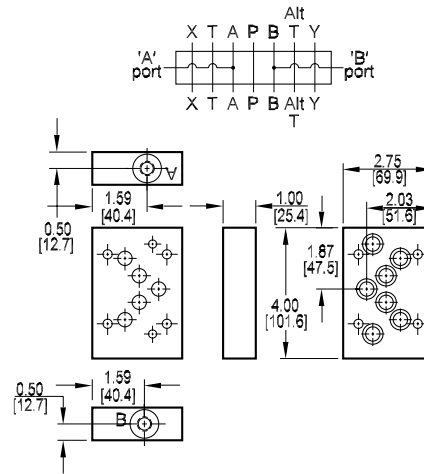

Specifications, descriptions, and dimensional data are subject to correction or change without notice or incurring obligation.

## Ordering Information

6

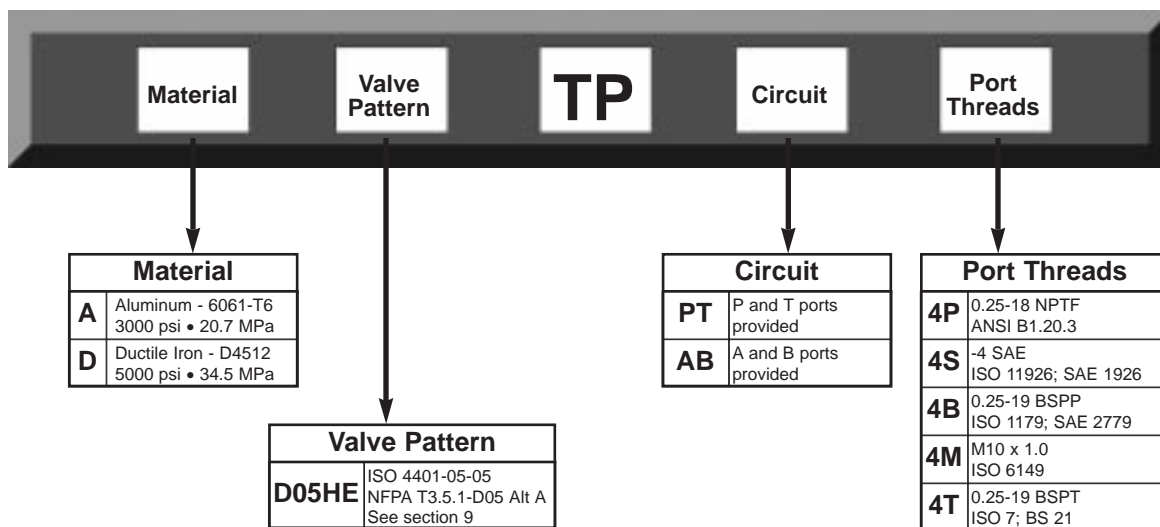



# D05 Tapping Plates with Pilot Ports

## X and Y Port Tapping Plate

Tapping Plate interface seal kit is supplied. \*

See page 124 for itemized list.

\* Plugs not supplied on metric ported parts.

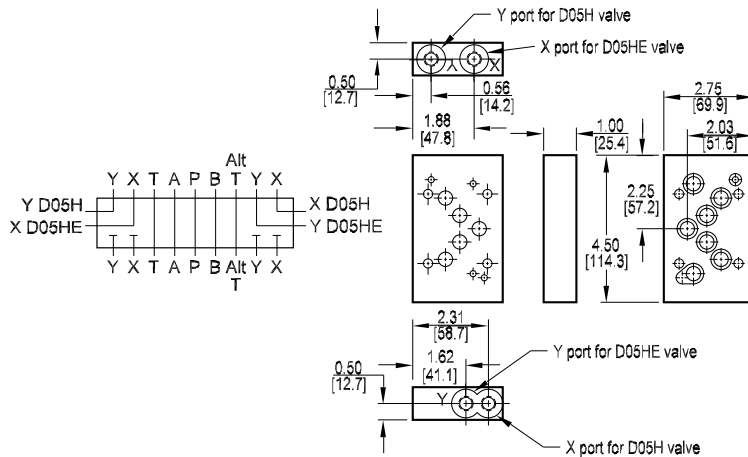

Specifications, descriptions, and dimensional data are subject to correction or change without notice or incurring obligation.

## 6 Ordering Information

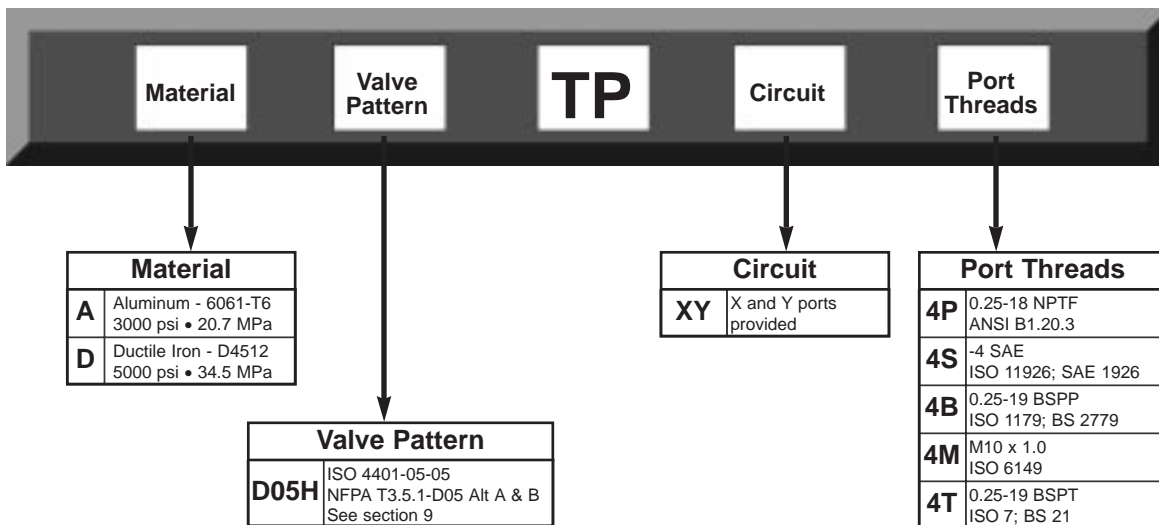



## D05 Tapping Plates with Pilot Ports

### Spot Drilled Tapping Plate

Tapping Plate interface seal kit is supplied.

See page 124 for itemized list.

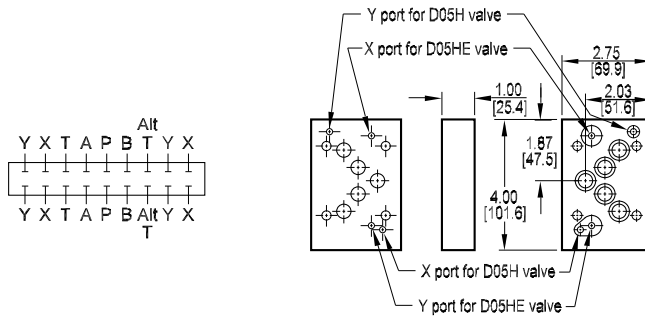

Specifications, descriptions, and dimensional data are subject to correction or change without notice or incurring obligation.

## Ordering Information

6

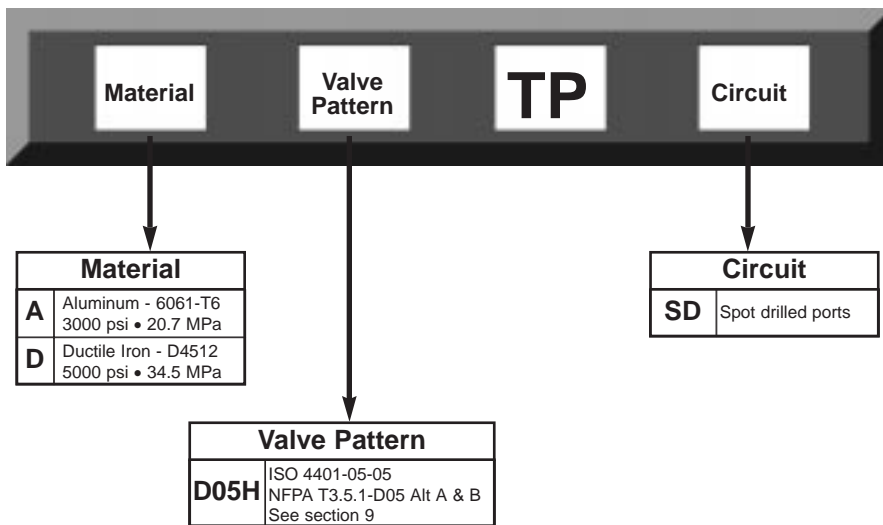



# D05 Tapping Plates with USA Pilot Ports

## D05(H) Two Station Tapping Plate

A<sub>1</sub> common to A<sub>2</sub>, B<sub>1</sub> common to B<sub>2</sub>

Tapping Plate interface seal kit is supplied.  
See page 124 for itemized list.

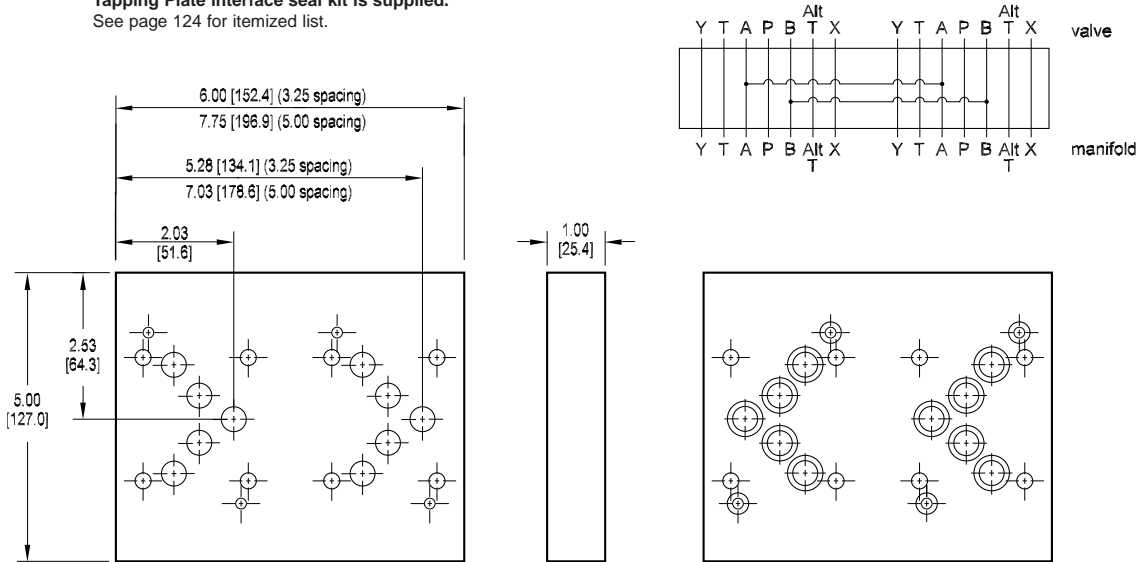

Specifications, descriptions, and dimensional data are subject to correction or change without notice or incurring obligation.

## 6 Ordering Information

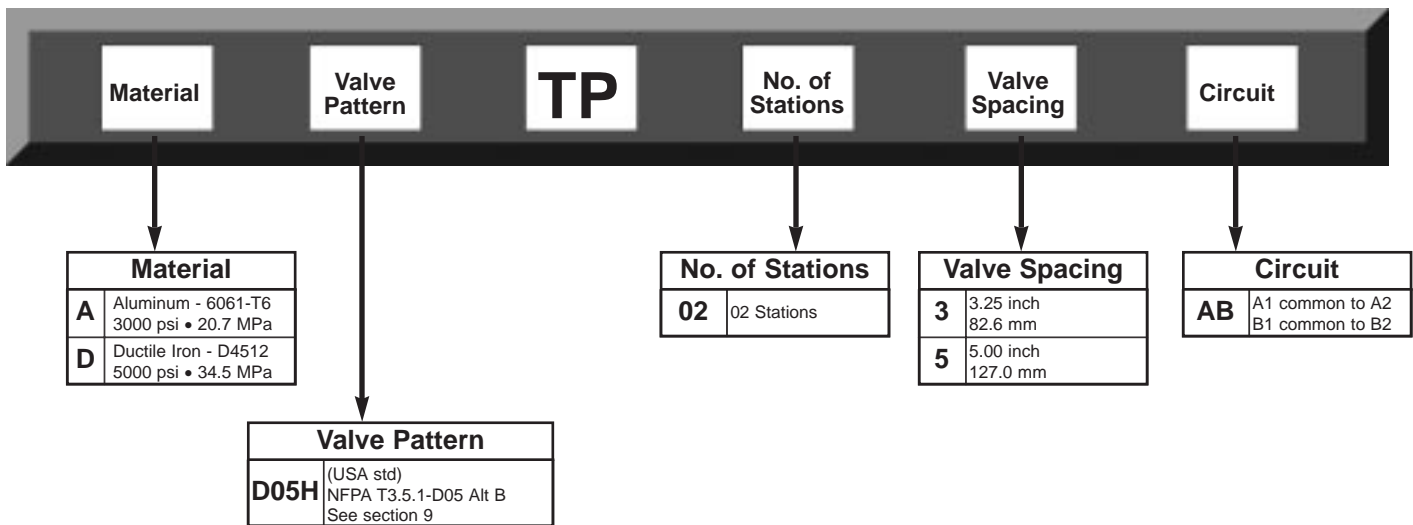



## D05 Tapping Plates with ISO Pilot Ports

### D05(HE) Two Station Tapping Plate

A<sub>1</sub> common to A<sub>2</sub>, B<sub>1</sub> common to B<sub>2</sub>

Tapping Plate interface seal kit is supplied.  
See page 124 for itemized list.

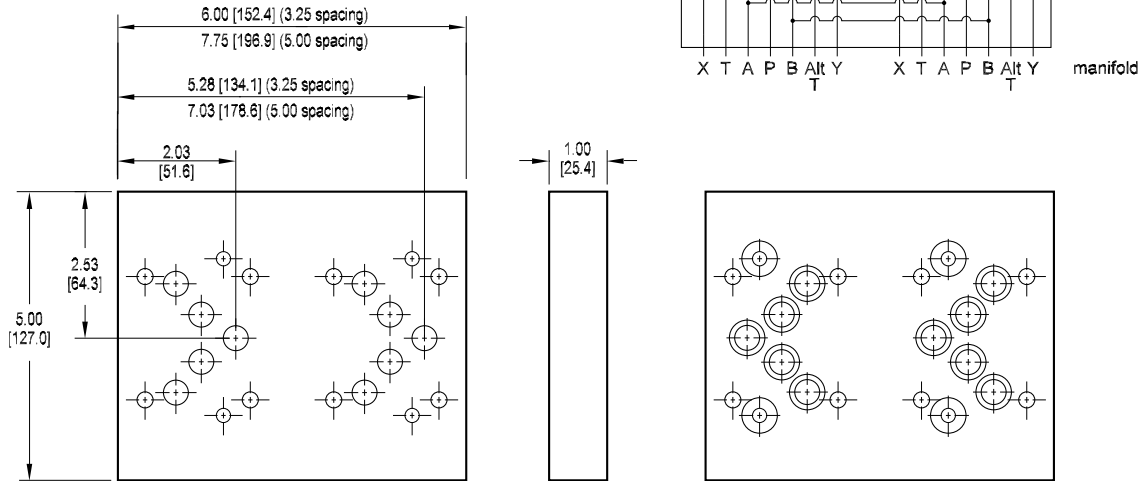

Specifications, descriptions, and dimensional data are subject to correction or change without notice or incurring obligation.

## Ordering Information

6

